

GeyserMax-Flow Rebuild Kits for GM-3900~GM-6200

加工符號

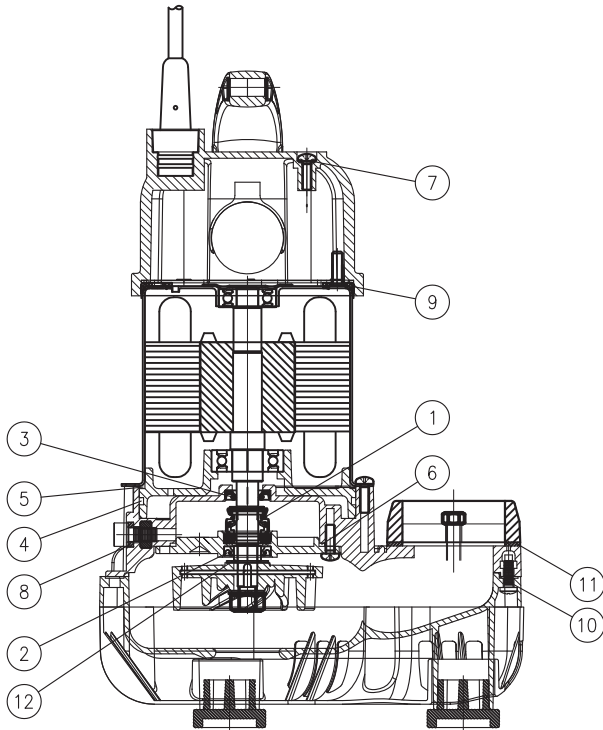

Oil Volume : 90cc

Rebuild Kit for GM-3900/GM-4700/GM-5400/GM-6200			
No.	Parts name	Specification	Q'ty
1	Mech. Seal	Single, SIC/CE-NBR, EA200N-M12 (EW-00839)	1
2	Oil Seal	NBR, Ø15*Ø26*5t/TC	1
3	Oil Seal	NBR, Ø12*Ø26*7t/TC	1
4	O-ring	NBR, Ø100*3.5t	1
5	O-ring	NBR, Ø110.72*3.5t (AS-245)	1
6	O-ring	NBR, Ø80*2.6t/DS-30/DC-139	1
7	O-ring	NBR, Ø4.5*2t	1
8	Gasket	(for oil seal) NBR, Ø8*Ø13.5*3t	1
9	Gasket	(for top cover) NBR, Ø118*6t	1
10	Gasket	(for pumps casing) NBR-70° 229.4*1.5t	1
11	Gasket	(for flange) NBR, 101*2t	1
12	Sleeve	SUS304	1

編號 NO.	修改內容 DESCRIPTION	核准 APPR.	日期 DATE	未特別註明處 (Unless Otherwise Specified) 圓角 (Filet) R2 拔模角 (Parting Angle) 1° 導角 (Chamfer) C1 去除毛邊 (Free Burrs) 一般角度公差 (Angular) ±0.5°	一般公差 ▽	單位 UNITS	材料 MATERIAL	圖名 TITLE	GM-3900/GM-4700/GM-5400/GM-6200
					0.5 ~ 6 以下 ±0.10 ±0.30	比例 SCALE	表面處理 FINISH	Rebuild kits	
					6 ~ 30 以下 ±0.20 ±0.50	日期 DATE	熱處理 H,R,C	零件料號 PARTA NO.	
					30 ~ 120 以下 ±0.30 ±0.70	2016.05.04		序號 SHEET:	
					120 ~ 315 以下 ±0.50 ±1.20	新設於 FIRST USED ON		版次 EDITION	1.0
					315 ~ 1000 以下 ±0.80 ±2.00	Ruta			
					1000 ~ 2000 以下 ±1.20 ±2.50				

Matala 亞馬技研有限公司
"Make water alive"
Matala Water Technology CO.,Ltd

