

AQUA-IONIZER PRO®

Aqua Ionizer Deluxe

Water Ionizers

Owner's Manual

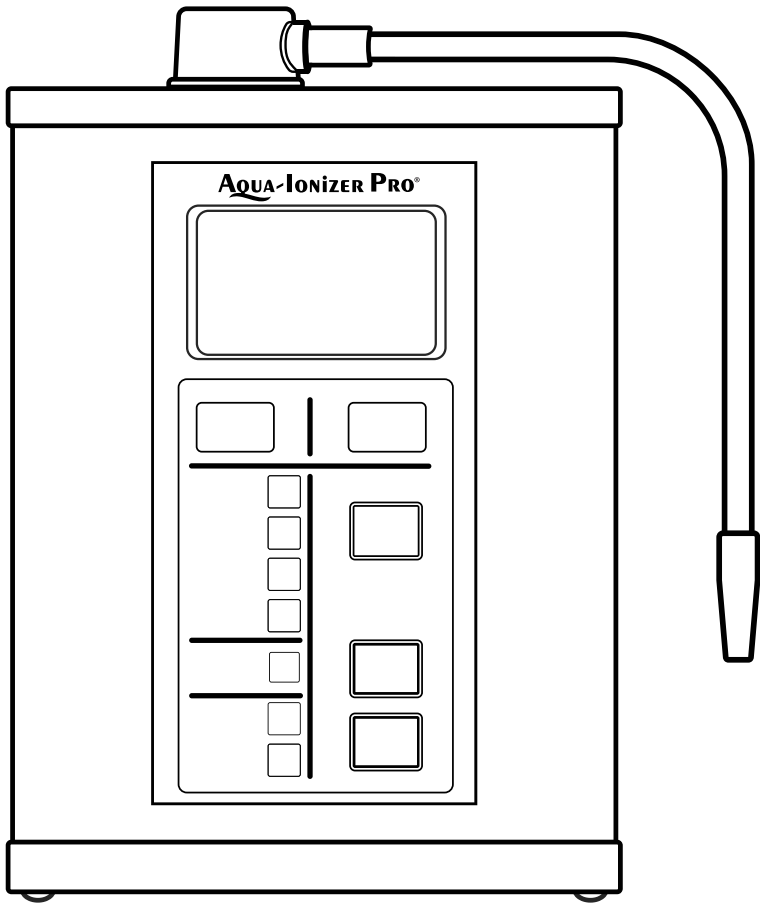

Deluxe Models: 9.5, 9.0, 7.5, 7.0

v. 1.01

TABLE OF CONTENTS

Safety Instructions & Symbols	1
Parts List	9
Water Ionizer Assembly Overview.	10
Installation Overview	11
Step 1 - Identify Required Connector(s) and attach Faucet Diverter Valve	12
Step 2 - Insert the Carbon Filter	14
Step 3 - Checking the preinstalled inlet and outlet hoses	15
Step 4 - Install the metal spout	16
Step 5 - Connect the water inlet hose to the faucet diverter valve	16
Step 6 - Check connections for leaks	17
Step 7 - Wall mounting your water ionizer (optional)	18
Step 8 - Plug in your water ionizer	19
Reverse Osmosis (R/O) & Well Water.	20
Understanding Your Water Ionizer	21
pH & ORP Testing Notes	22
Understanding the LCD Display.	23
Understanding the pH Presets	24
Dispensing Water	25
Cleaning Functions	26
Filter Replacement & Descaling	27
Troubleshooting	29
Warranty.	31
Return Policy & Damage Liability Waiver	32
Technical Specifications	33

SAFETY INSTRUCTIONS & SYMBOLS

Safety Instructions & Symbols:



Avoid the specified action as it may destroy the unit, cause serious injury or even death.



Avoid the specified action as it may destroy the unit or cause serious injury.

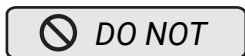

Do NOT perform the specified action.



The specified action is very important and must be completed for the unit to function properly.



Most City Water In The USA Works Great

Source water requirements - Please pay attention to the source water requirements outlined below prior to installing and operating your water ionizer.

- The source water entering the water ionizer must meet applicable local standards that make it suitable for drinking. Despite the unit's built-in water filter, it should NOT be attached to a water source not meant for drinking. The purpose of the carbon filter is to remove residual chlorine, other chemicals, and odors from water that is already suitable for human consumption. The filter is NOT intended as the sole purification source for the water ionizer - use in this manner will void the warranty, reduce the unit's performance, shorten its operational life, and could jeopardize the health and life of anyone drinking water that could potentially be harmful.
- The water flow entering the water ionizer from the source water connection must be 0.8 liters per minute or faster for the water ionizer to operate properly. If the water flow is too slow, the water ionizer may not be able to induce water flow and therefore cannot start normally. If your municipal or other water source flows slower than 0.8 liters per minute, you may need to install a booster pump.
- The pressure of source water that goes into the unit must be under 43.5 pounds per square inch (psi)/.03 megapascals (MPa) for your water ionizer to operate properly and to avoid damaging the unit. If you water pressure is higher than this, you should install a water pressure reducer to lower the source water pressure before it's fed into your water ionizer.

SAFETY INSTRUCTIONS

 CAUTION

**If you have an R/O (Reverse Osmosis) System
or low pH WELL WATER,**

- or -

If you are not on city or municipal water, call our
customer service number for filter options.

Questions Please Call:

1-888-601-5886

 IMPORTANT

 DO NOT

Do NOT Install your water ionizer in any of the following locations:

- Near an open flame, in direct sunlight or anywhere temperatures could exceed 140° F (60° C);
- Near flammable liquids;
- Outdoors or any place where the unit could be directly exposed to rain, snow, high winds, or other weather elements;
- Saunas or other facilities with unusually high levels of humidity; or
- Any spot where water or other liquids might drop on the unit's exterior.

 WARNING

 IMPORTANT

To avoid electrical shock and fire hazards:

- Be sure the electrical plug is seated fully in the power outlet.
- Do NOT bend, pinch, clamp, place heavy objects upon, modify, or otherwise damage the unit's power cord or plug.
- Do NOT plug the unit in if the cord, plug, or outlet is damaged.
- Do NOT drag the unit by its power cord or plug.
- Contact a qualified electrician immediately if the cord or plug becomes damaged.

SAFETY INSTRUCTIONS



WARNING



IMPORTANT

- Do NOT share the electrical outlet used for your ionizer with other electrical appliances. See Page 7 for more information.
- Use only alternating current 110V power supply. Exceeding the rated power rating may damage the unit and/or cause a fire.
- Do NOT attempt to plug in, unplug, or otherwise operate your water ionizer if your hands are wet.
- Do NOT submerge the unit in water nor use alcohol, flammable, toxic, or corrosive chemicals when cleaning this unit. You should clean the exterior of the unit by using a slightly damp cloth with a small amount of dish washing liquid.
- If the unit falls into or is doused by water or any other liquid, immediately remove from power outlet.
- This appliance is not intended for use by people (including children) with reduced physical, sensory, or mental capabilities, nor by individuals with otherwise limited knowledge, skills, and abilities regarding the operation of electrical appliances in general and water ionizers in specific unless they have received supervised and/or written instruction (such as this manual) in their safe operation.
- Young children should NOT attempt to operate the unit.



CAUTION



DO NOT

- Do NOT place your water ionizer closer than 3 feet from your oven, furnace, space heater, or any other active heat sources or devices.
- Do NOT disassemble, attempt to repair, or modify your water ionizer. This should only be done by a professional service technician.



CAUTION

- If you have existing water hoses from a previously owned water ionizer or other water dispensing, filtration, or purification devices, these hoses should be discarded and the new hoses provided with your new water ionizer should be used instead.

SAFETY INSTRUCTIONS



WARNING



IMPORTANT

Health Issues: If any of the following apply to you, please consult your physician before drinking or continuing to drink ionized alkaline water.

- You have kidney disease, renal failure, and/or have difficulty discharging/eliminating potassium in which case you should generally NOT ingest alkaline water;
- You are receiving medical treatment for another disease or illness;
- You are chronically ill or otherwise in very poor health.



CAUTION



IMPORTANT

Beginning to Drink Alkaline Water: Your body may take a while to get used to drinking alkaline water.

- When drinking alkaline water for the first time, dispense the water using your unit's "drinking" (On the Deluxe 9.5; "Initial Drinking" on Deluxe 9.0, 7.5, 7.0) setting and consume only small amounts, 8 to 16 ounces (0.25 to 0.5 liters) per day.
- Continue this practice for at least 2 weeks prior to advancing to your units higher pH value "High-Antioxidant" (On the Deluxe 9.5; "Drinking" on Deluxe 9.0, 7.5, 7.0) setting at which time you should try to consume 32 to 64 ounces (1 to 2 liters) of alkaline water per day.
- Attempting to drink higher pH value water before your body becomes used to alkaline water may result in temporary digestive, dermatological, or other symptoms.



CAUTION



DO NOT

Alkaline Water & Medications: Do NOT drink alkaline water prior to, with, or immediately following taking tablets or other oral medications. Instead, use your unit's "Purified Water," i.e., filtered but not ionized, water setting. As a general rule, you should not consume alkaline water within 45 mins. to one (1) hour either before or after taking medication. This is to avoid "time release" issues, unless approved by your medical professional.

SAFETY INSTRUCTIONS

IMPORTANT

Storing Ionized Water: Under normal temperature conditions, alkaline water stored properly in a sealed, insulated container will retain its ionized properties for at least 24 hours and up to 48 hours when refrigerated. Alkaline levels may remain for longer periods.

- Do NOT store ionized water in metal containers. It should only be stored in plastic, glass, or ceramic containers.
- Exposing the container to direct sunlight may shorten the period that alkaline water is able to retain its ionized properties.

CAUTION

Cosmetic Water Use: When using mildly acidic water from your water ionizer's "Beauty" setting for skin care, as an astringent or for hair care, please discontinue use and consult your physician if you develop a skin rash or other allergic reaction.

CAUTION

IMPORTANT

Pets & Ionized Water: Dogs, cats, and other mammals may benefit from drinking ionized water. However there are a few simple rules:

- Especially if your animals have any preexisting health problems, consult your local veterinarian before giving them alkaline water and/or following any negative health reaction to the alkaline water.
- Start them off slowly on "Drinking" (On the Deluxe 9.5; "Initial Drinking" on Deluxe 9.0, 7.5, 7.0) setting and keep them there for at least 2 weeks prior to moving to the "High-Antioxidant" (On the Deluxe 9.5; "Drinking" on Deluxe 9.0, 7.5, 7.0) setting. As a general rule, it's probably best not to exceed 9.0 pH.
- Do NOT give your pet alkaline water within 45 mins. to 1 hour before or after meals. Use the "Purified Water" setting instead. The higher pH levels can neutralize their stomach acids making it more difficult for them to absorb nutrients.
- As with humans, Do NOT give your pets ionized water within 45 mins. to 1 hour prior to, with, or after taking medication. Doing so can alter the intended absorption rate of the drug.
- While the "Beauty" water setting can be used to treat your pet's minor wounds and improve its skin and coat, you should check carefully for any allergic reactions or skin irritation.

SAFETY INSTRUCTIONS

CAUTION

Fish & Aquariums: Unless you are an experienced aquarium owner or qualified aquatic life professional, do NOT introduce ionized water to your aquarium without knowing the precise alkaline or acidic water settings applicable to your particular fish species. Fish may become ill or die if their water's pH balance is changed or changed too quickly.

Exotic Pets: Lizards, snakes, turtles, frogs, and other reptiles and amphibian species vary dramatically in the pH levels to which they are suited. Please contact your vet or pet shop owner prior to giving them ionized water.

Plants: Different plants thrive on water of varying pH levels. For example, some plants prefer more alkaline environments while others perform better in more acidic ones. Consequently, before watering your plants with ionized water, you should determine specifically the type of pH balance most conducive to the growth of your specific plants.

IMPORTANT

Flushing Residual Water: Because a certain amount of water remains trapped in your water ionizer's filters and tubing, you should briefly run water through your ionizer prior to each use.

- In order to remove any residual water left in your water ionizer, you should generally dispense water from the unit for approximately 5 seconds before each use.
- If you have not used the unit for at least 2 days, you should dispense water from the unit for at least 3 minutes. before using it.

WARNING

IMPORTANT

Tainted & Leaking Water: If any of the following occurs, stop drinking water from your ionizer immediately and contact Real Spirit USA at (888) 601-5886.

- Taste or pH testing levels reveal that water dispensed from the unit, which should be alkaline, is coming out acidic;
- Residual water appears to be dripping from the unit.

SAFETY INSTRUCTIONS

 CAUTION

 DO NOT

Continuous Operation: Do NOT exceed the following maximum continuous operation time frames for your water ionizer:

- Do NOT operate the unit in any Alkaline or Acidic setting for more than 30 minutes continuously.

 WARNING

 IMPORTANT

Consumable Water Limits: Though extremely high or low pH water can be used for purposes besides drinking, e.g. cooking food, cosmetic purposes, or household cleaning, etc. humans, unless directed by their physician for some unusual medical reason, should not generally drink water higher than 10 pH nor lower than 7 pH.

 WARNING

 IMPORTANT

Grounding: Your water ionizer should only be connected to an electrical circuit that is protected by a “ground-fault circuit interrupter,” (GFCI)

- This appliance must be grounded. In the event of a malfunction or breakdown, grounding will reduce the risk of electric shock by providing a path of least resistance for an electric current.
- This appliance is equipped with a cord having an appliance-grounding conductor and a grounding plug.
- This plug must be plugged into an appropriate outlet that is installed and grounded in accordance with all local codes and ordinances.
- Improper connection of the appliance-grounding conductor can result in a risk of electric shock.
- Check with a qualified electrician or service representative if you are in doubt as to whether the appliance is properly grounded.
- Do not modify the plug provided with the appliance; if it will not fit the outlet, have a proper outlet installed by a qualified electrician.

SAFETY INSTRUCTIONS

! IMPORTANT

Waste Disposal: In compliance with the "Waste Electrical and Electronic Equipment Directive"

- This marking indicates that this product should not be disposed with other household waste throughout the EU.
- To prevent possible harm to the environment or human health from uncontrolled waste disposal and to conserve material resources, this product should be recycled responsibly.
- To dispose of your product, please use your local return and collection systems or contact the retail where the product was purchased.

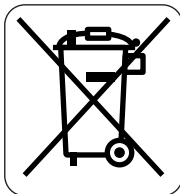

PARTS LIST



Note: As a result of minor technical or aesthetic changes, some ionizer parts may appear slightly different in appearance or color than depicted on product packaging or in this manual. Should this occur, the part (s) remain usable and should be installed and used in accordance with this product manual.

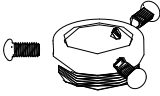

3-Bolt Faucet Connector



Inner Thread Faucet Joint



Dual Thread Faucet Connector

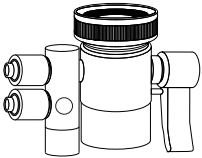

Faucet Diverter Valve

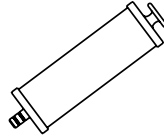

Carbon Water Filter
(Standard City Water)
- Blue -

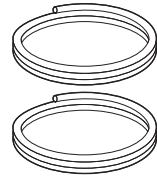

Pre-Installed Inlet and Outlet Hose

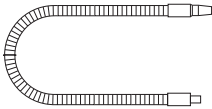

Flexible Metal Spout



Turbine
(Spare)



Water Ionizer Descaling Powder



Wall Mount Template



Screws

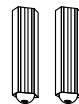

Wall Anchors

WATER IONIZER ASSEMBLY OVERVIEW

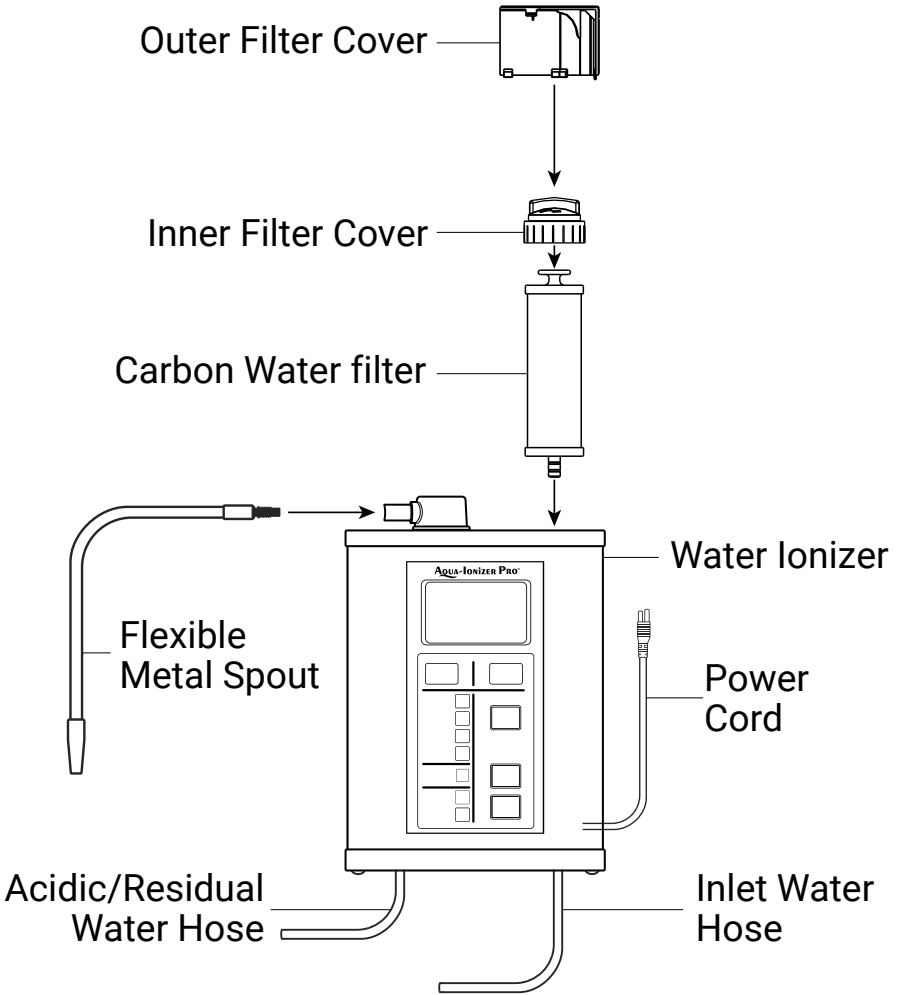

! IMPORTANT

For Installation Videos Visit:
www.aquaionizerpro.com/pages/install

SCAN WITH YOUR SMART PHONE



INSTALLATION OVERVIEW

*Shown with Optional Wall Mount & Faucet Diverter

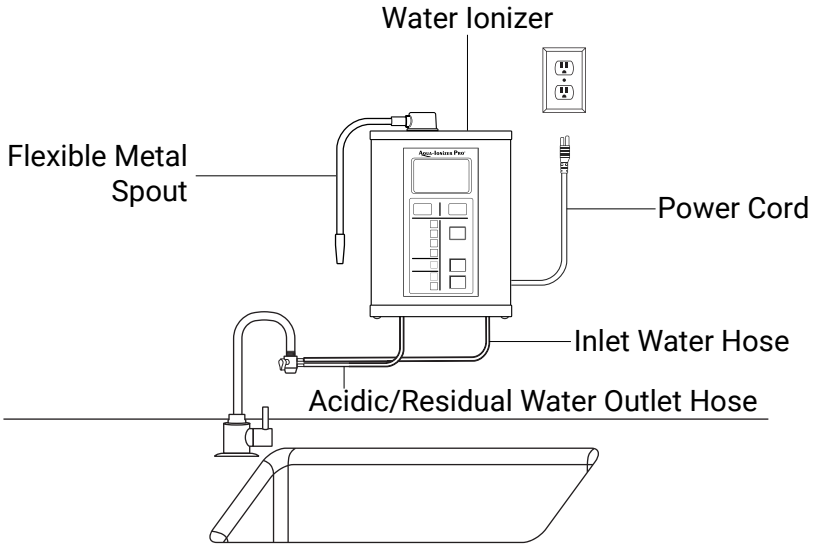

! IMPORTANT

For Installation Videos Visit:
www.aquaionizerpro.com/pages/install

SCAN WITH YOUR SMART PHONE



Installation Order: There are 8 simple steps to installing your water ionizer each of which is described in detail beginning on the next page. Please follow each of the following steps in order:

1. Identify required connector(s) and attach the faucet diverter valve.
2. Insert the inner carbon filter.
3. Checking the pre-installed inlet and outlet hoses.
4. Install the metal spout.
5. Connect the water inlet hose to the faucet diverter valve.
6. Check connections for leaks.
7. Wall mounting your water ionizer. *(Optional)*
8. Plug in your water ionizer.

INSTALLATION

Step 1 - Identify Required Connectors/Attach Faucet Diverter Valve

Standard home faucets typically fall into 1 of 3 categories:

1.
Threaded on outside

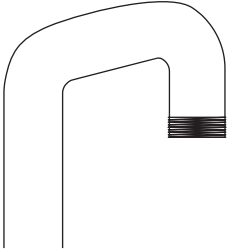

2.
Threaded on inside

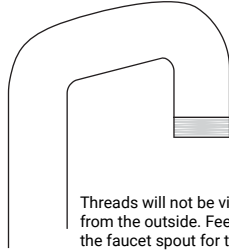

Threads will not be visible from the outside. Feel inside the faucet spout for threads.

3.
Unthreaded

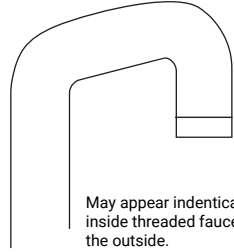

May appear identical to an inside threaded faucet from the outside.

The type of faucet you have will determine whether you can attach the faucet diverter valve directly to your faucet OR which of the following faucet connectors you will have to use.



Dual-Thread
Faucet Connector



Inner Thread
Faucet Joint

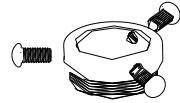

3-Bolt Faucet
Connector

1. **Threaded on outside:** You will usually not need to use a connector. Simply screw the faucet diverter valve directly onto the faucet.

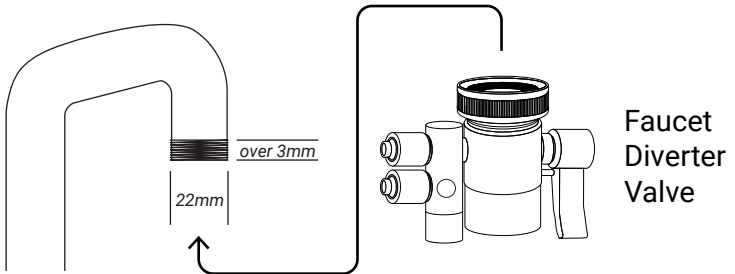

INSTALLATION

2. **Threaded on inside:** Being sure to first insert the washer, screw in the dual-threaded faucet connector into the faucet. Then screw the faucet diverter valve into the dual-thread connector

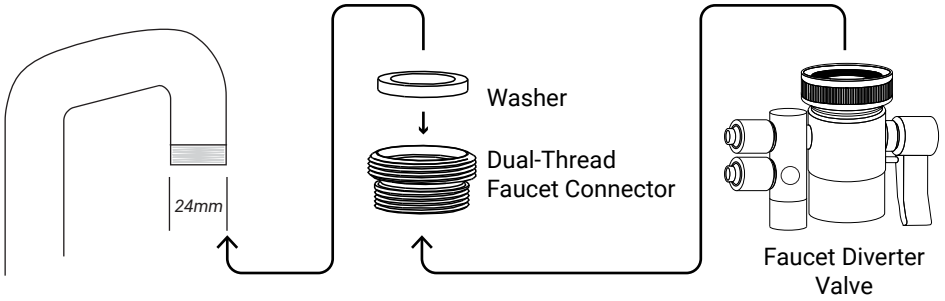

3. **Unthreaded:** If your faucet has neither inside nor outside threads, loosen the bolts on the 3-bolt faucet connector, slip it over the end of the faucet pressing upward firmly then tightening bolts, securely locking it onto the faucet. Next screw the inner faucet thread joint securely into the bottom of the 3-bolt faucet connector. Then screw the faucet diverter valve onto the inner thread joint which you've just attached to the 3-bolt faucet connector.

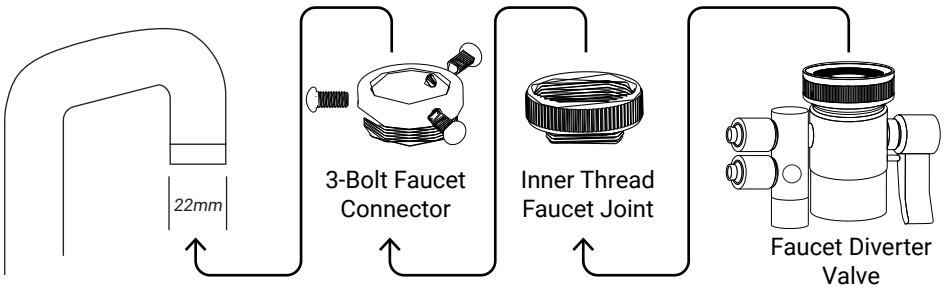

! IMPORTANT

In some instances, either because the threads are damaged, too wide, or too narrow, you may need to use the 3-bolt faucet connector assembly method even on threaded inside or outside faucets.

INSTALLATION

Step 2 - Insert the Inner Carbon Filter

Though the inner carbon filter is shipped with your water ionizer, it is NOT preinstalled. Simply remove the filter from the box, remove any packaging materials, and install it in the following manner:

1. Remove the water ionizers outer filter cover by pressing on the arrow with your thumb, squeezing gently with your finger and pulling up.
2. Firmly grasp the inner filter cover and twist it counter-clockwise to open.

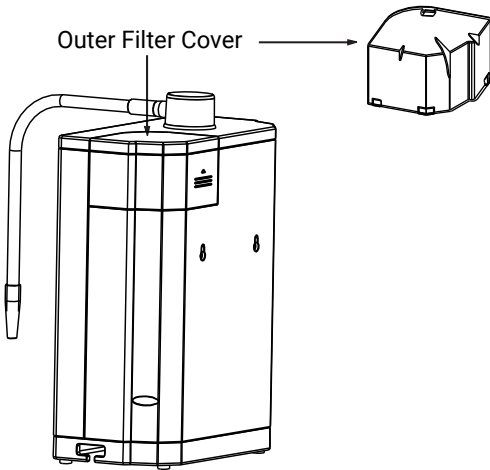

Fig. A

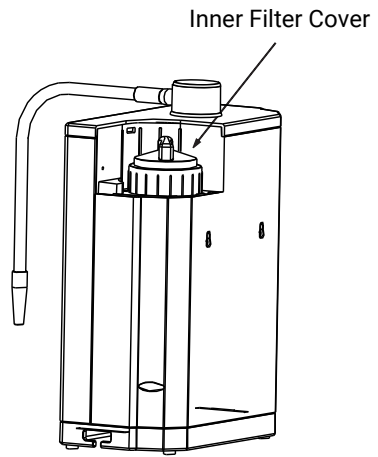

Fig. B

3. After unpacking the new inner carbon filter, prime the filter by holding the end with the sealing ring on it under running tap water for 3 minutes to flush away any loose carbon particles, & remove excess air.

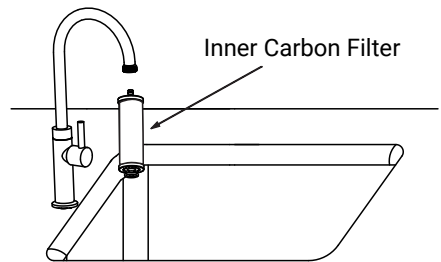
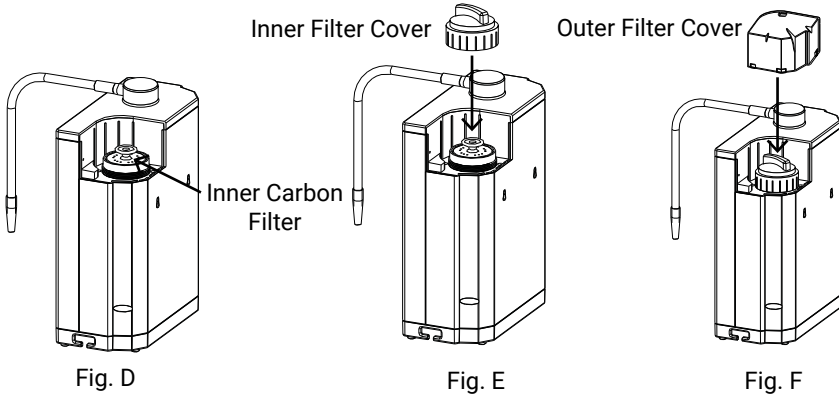

Fig. C

INSTALLATION

4. Insert the newly primed inner carbon filter into the open filter chamber as shown in Fig. D.
5. Re-seat the inner filter cover and twist it clockwise to close the filter inside the filter chamber, hand tighten to ensure it won't leak. Reinstall the outer filter cover.



Replacing Filters: The inner carbon filter should be replaced every 2000 liters, approximately 6 months to 1 year under normal use conditions. Regional, environmental, and other differences in water quality, such as more polluted municipal water, may require the filter to be replaced more often. If you notice unusual odors or taste in your water, replace the filter as necessary. NOTE: the reset filter light will turn on every 2000 Liters.

Step 3 - Checking the preinstalled inlet and outlet hoses.

1. Your ionizer will come with two 1/4 inch white hoses installed.

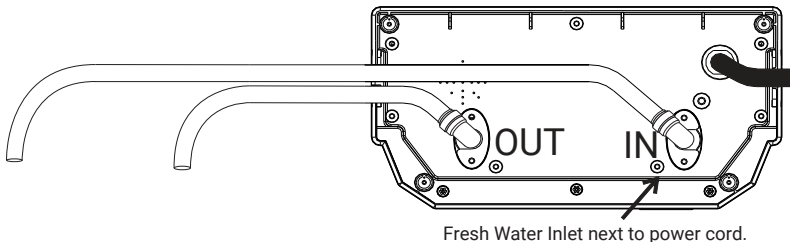

2. The OUT hose will have a RED dot that will match up with the RED dot on the diverter in the next step.

Note: You may need to cut the hoses shorter to fit your set up. Please wait until your installation is complete before cutting the hoses.

INSTALLATION

Step 4 - Install Metal Spout

REMOVE the rubber stopper.

Screw the flexible metal spout clockwise into the outlet connector on top of the water ionizer.

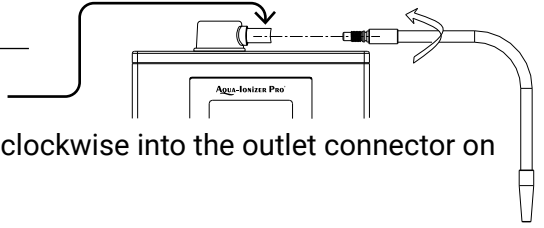

Step 5 - Connect the water inlet hose to the faucet diverter valve.

Unscrew the caps on the diverter and slide the caps over the hoses. Connect the inlet water hose to the top faucet diverter valve and the acidic/residual water outlet hose into the bottom of the valve. Push each hose on firmly and screw on the caps to ensure a secure connection. These may require a good amount of force to prevent any leaks.

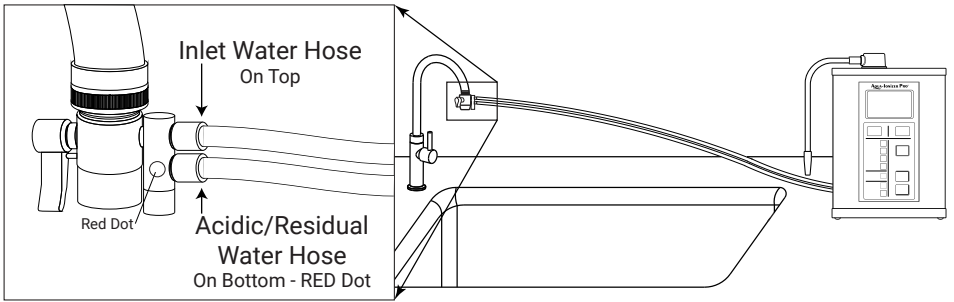

Step 5 Note: How to install the hoses onto the diverter

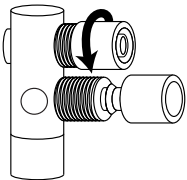

Unscrew caps

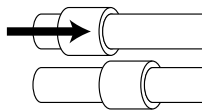

Slide cap over hose

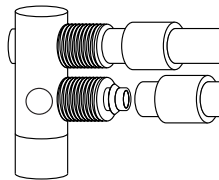

Push hose on firmly

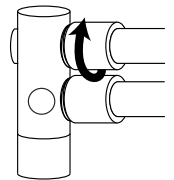

Screw on caps

! IMPORTANT

NOTE: The out hose, on the bottom of the ionizer, will have a RED dot that will match up with the RED dot on the diverter.

Be sure that the metal spout and the white 1/4" hoses for the source water ("IN") and the acidic/residual ("OUT") are attached correctly to the bottom of the unit as described in steps 3 & 4. Remember the water inlet is closer to the power cord.

INSTALLATION

Step 5 - Installation Notes

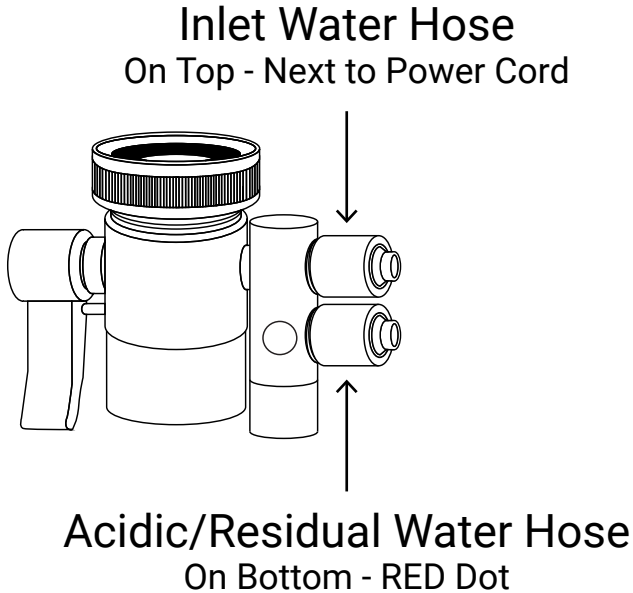

Step 6 - Check Connections for Leaks

After completing all prior installation steps and making sure all hoses are securely attached, you should perform the following tasks:

1. With the faucet diverter valve switched on and source water flowing into the unit, confirm that there are no leaks from any of the hose connection points, the inner filter cover, nor from anywhere else on the water ionizer. This process will also flush any remaining air from the inner carbon filter.
2. If there are no apparent leaks, turn off the water and temporarily plug the unit into the proper electrical outlet as described in Step 8 - Plug in the Water Ionizer.
3. After fully installing and priming the carbon water filter, if this is the first time you've installed your water ionizer, unplug the unit and proceed to Step 7 - (Optional) Wall Mounting your Water Ionizer.

INSTALLATION

Step 7 - Wall Mounting your Water Ionizer (*Optional*)

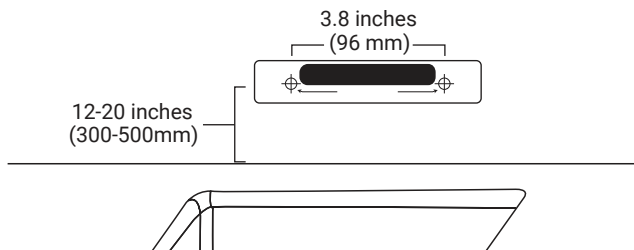

1. Position the water ionizer in a safe location near the sink counter and a suitable electrical outlet.
2. Using the provided Mounting Guide, remove the backing, and position the guide so that the two holes are level and are between 12 and 20 inches above the counter. Stick the guide to the wall.
3. Once the mounting guide is properly placed and level, using a 1/4" drill bit, drill 2 holes, approximately 2 inches deep. If you have applied the guide correctly, the distance between the drilled holes will be 3.8 inches.
4. Insert the screw anchors into the two holes, ensuring each is flush with the wall.
5. Screw in the provided screws into the anchors, be sure to leave approximately 3/16 inches of the screw head exposed. We will use this to mount the ionizer onto.
6. Affix your water ionizer to the wall by slipping the screw notches on the back of the unit over the exposed screw heads while pushing down gently to secure the unit to the wall.

INSTALLATION

Step 8 - Plug in your Water Ionizer

IMPORTANT

Before plugging in your water ionizer, confirm the power outlet is 110V/60Hz and grounded.

1. When you first plug in your water ionizer, a water indicator, e.g. “drinking” will illuminate.
2. Switch on the faucet diverter valve with water flowing into the water ionizer.
3. When your water ionizer initially starts up, it will briefly enter auto cleaning mode. Do NOT unplug the water ionizer when it’s in auto cleaning mode, doing so can result in damage. Let the water run until the music stops. (See “Enhanced Cleaning” on page 26 for more info)

INSTALLATION HELP

If you have any questions regarding installation visit:

www.aquaionizerpro.com/pages/install

Or give us a call

888-601-5886

Reverse Osmosis (R/O) or Well Water

If your water source is from a tested safe-to-drink well/ground water or has passed through a Reverse Osmosis system, you may not have enough beneficial minerals in your water for the water ionizer to function at its full potential.

**Please contact us at the number below
for a FREE MINERAL FILTER***

*Only valid within 60 days of initial purchase

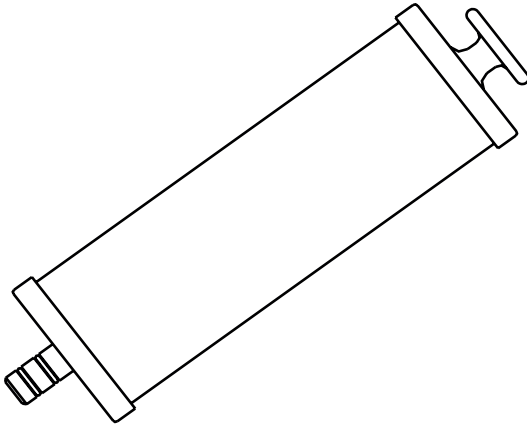

This filter will add back the beneficial minerals that your R/O or well water is missing.

**Any Questions Call:
(888) 601-5886**

UNDERSTANDING YOUR WATER IONIZER

Filter Reset



When the Filter Reset light comes on, it's time to change the filter and descale the water ionizer.

After changing the filter, hold down the Filter Reset/SET button for 10 seconds until the RED light turns off.

Note: The liter counter will not reset. Your filter light will turn on every 2000 liters. We recommend changing your filter every 6 months. See page 27 for more information.

pH Presets

Factory pH Value Presets: Your water ionizer's primary pH settings are preset within the following ranges and are dependent on source water.

Aqua Ionizer Deluxe 9.5

ALKALINE SETTINGS

COOKING



10.0 - 11.5 pH

BREW
TEA/ COFFEE



9.5 - 10.0 pH

DRINKING



7.5 - 8.5 pH

HIGH
ANTI-OXIDANT



8.5 - 9.5 pH

PURIFIED

PURIFIED
WATER



Same pH
as your
Source Water

(Most Municipal Tap Water is 7.0 pH)

ACIDIC SETTINGS

BEAUTY



6.0 - 6.5 pH

CLEANING



3.5 - 6.0 pH

Aqua Ionizer Deluxe 9.0, 7.5, 7.0

ALKALINE SETTINGS

COOKING



10.0 - 11.5 pH

BREW
TEA/ COFFEE



9.5 - 10.0 pH

DRINKING



8.5 - 9.5 pH

INITIAL
DRINKING



7.5 - 8.5 pH

PURIFIED

PURIFIED
WATER



Same pH
as your
Source Water

(Most Municipal Tap Water is 7.0 pH)

ACIDIC SETTINGS

BEAUTY



6.0 - 6.5 pH

CLEANING



3.5 - 6.0 pH

PH & ORP TESTING NOTES

Impact of Environmental & Other Factors on pH - Different regional, environmental, and testing factors such as the quality, pH level, Total Dissolved Solids (TDS), source water temperature, and the flow rate through the water ionizer can all cause variations in the pH level of the water dispensed from your water ionizer. For example, the referenced pH preset values were derived from 68°- 77° F (20° - 25° C) source water with a neutral pH of approximately 7.0, containing 100-150 parts per million of TDS flowing at 2L (0.5 gal) per minute.

DO NOT

DO NOT use litmus paper to evaluate pH. Most commercially available litmus paper is a much less accurate tool for measuring pH than the ionizer specific pH reagent (testing liquid).

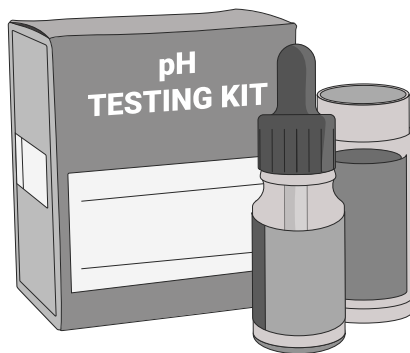

**Would You Like a Free* pH Test Kit?
Call 1-888-601-5886**

**Only valid within 60 days of initial purchase*

ORP Testers

Caution using store bought ORP Testers. Many of these testers are designed for Fish Tanks and Swimming Pools only. These NON-Professional ORP testers are not designed to be accurate after -100 ORP.

As a general rule, if your Ionizer is producing Alkaline Water it is also producing negative ORP.

Every ionizer is tested with a Laboratory Certified ORP Tester before it leaves our factory to ensure proper functionality.

UNDERSTANDING THE LCD DISPLAY

In addition to the alerts and indicators described below, the LCD displays in 1 of 7 different colors to indicate which of the unit's 7 presets is current selected.

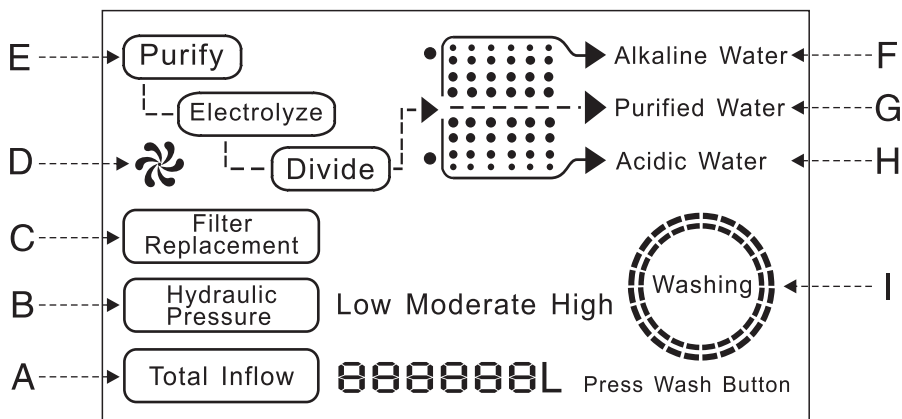

- A. Total Inflow** - Displays the total water flow through the water ionizer.
- B. Hydraulic Pressure** - Water pressure of water running through the water ionizer. You always want Low or Moderate, never High. You can adjust the water flow rate at the supply tap knob.
- C. Filter Replacement** - When displayed, replace the filter. See pg. 21 for more information.
- D. Water Flow Indicator** - Rotates to confirm that inlet source water is flowing into the water ionizer.
- E. Purify, Electrolyze, & Divide** - Confirms your water ionizer is progressing through the various stages of water filtration, electrolysis, and water separation stages.
- F. Alkaline** - Confirms the ionizer is dispensing alkaline water.
- G. Purified** - Confirms the ionizer is dispensing purified water.
- H. Acidic** - Confirms the ionizer is dispensing acidic water.
- I. Washing** - Lets you know the water ionizer is in the automatic cleaning mode. Note: NEVER unplug the ionizer in washing mode. Doing so may damage the unit.

UNDERSTANDING THE PH PRESETS

Your water ionizer has 7 pH presets: 4 Alkaline, 1 Purified, and 2 Acidic. Each is shown below, along with its control panel icon, factory set pH range, and the general application(s) of each setting.

ALKALINE SETTINGS

COOKING

10.0 - 11.5 pH



This setting is ideal for cooking since alkaline water dramatically improves the flavor of veggies, rice, pasta, and soups. Water from this setting is also perfect for washing fruits and veggies, removing not only dirt and bacteria, but also chemical pesticides and fertilizers far more effectively than regular tap water. It even makes a great stain remover for removing coffee, oil, grass, and other stubborn stains.

BREW TEA/ COFFEE

9.5 - 10.0 pH



Alkaline water at this setting enhances the flavor, color, and aroma of both coffee and tea.

DRINKING

8.5 - 9.5 pH



DELUXE 9.0, 7.5, 7.0

Drinking 2 or more glasses daily of alkaline water acts as a powerful antioxidant and can help offset the effects of eating highly acidic foods such as meats, egg yolks, fried foods, processed foods, coffee, and aids in hydration.

INITIAL DRINKING

7.5 - 8.5 pH



"DRINKING" ON DELUXE 9.5

If you are new to drinking ionized alkaline water, you should start by drinking small regular amounts, ionized alkaline water at this level daily for a week or two before progressing to the higher Drinking ("High Anti-oxidant" on the Deluxe 9.5) setting since it may take your body a short while to adjust to the higher alkaline water setting.

HIGH ANTI-OXIDANT

8.5 - 9.5 pH



EXCLUSIVE TO DELUXE 9.5

This setting will use electrolysis to supercharge your water with antioxidants as it ionizes your water. Using your ionizer in this way also breaks down oxygen molecules into microclusters that are easier for your cells to absorb, battling free radicals that damage your cells through oxidation with -450 to -900 ORP.

PURIFIED

PURIFIED WATER

Approx. 7.0 pH



This setting filters, but does not ionize water. It should be used when taking pills or other medications. Consuming ionized water within 1 hour of taking medications can affect a drug's absorption rate, resulting in harmful or unintended consequences. This option is also ideal for use in baby food preparation, since ionized water may be harmful or difficult for children under the age of one year to digest.

ACIDIC SETTINGS

BEAUTY

6.0 - 6.5 pH



Acid water from this setting makes a great skin exfoliant, removing dead skin cells and acts as an astringent which tightens the skin, removes fine lines and wrinkles. And, because acidic water kills surface bacteria on the skin, it also helps fight acne and blemishes without harmful chemical residue. Shampooing and rinsing your hair with water from this setting enhances shine, manageability, and reduces breakage.

CLEANING

3.5 - 6.0 pH



Highly acidic water from this setting makes an extremely effective cleaning, disinfecting, and antibacterial agent. It is particularly suited for cleaning kitchen and bathroom surfaces such as counter tops, cutting boards, sinks, toilets, tubs, showers, mirrors, and linoleum and tile floors. Best of all, while acidic water outperforms many commercial cleaners, it does so without all the harmful chemicals and toxins.

DISPENSING WATER

A. Once properly installed, and with water flowing into the unit, your water ionizer will enter standby mode, displaying the most recent selected preset, e.g. Drinking.

B. To change to a different preset:

1. Press the ALKALINE button to cycle through each of the 4 settings (3 alkaline and 1 purified on the Deluxe 9.5). Each press advances you to the next preset.
2. On the Deluxe 9.5, Press the ANTI-OXIDANT to select filtered high antioxidant water.

On the Deluxe 9.0, 7.5, & 7.0, press the PURIFIED to select filtered water.

3. Press the ACIDIC button to cycle between the 2 acidic settings.

C. After making your water selection:

1. Turn on your water faucet.
2. Flip the Faucet Diverter Valve to the ON position, diverting the water into the water ionizer which will then begin dispensing the water at your desired preset.

D. Once you're done dispensing water, simply shut off your faucet and/or the Faucet Diverter Valve.

Deluxe 9.5

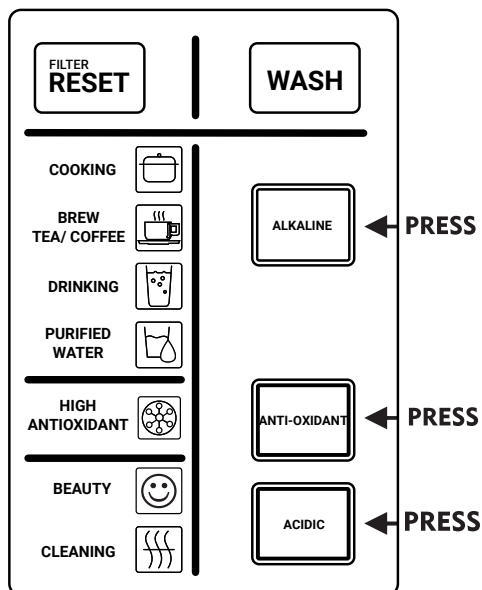

Deluxe 9.0, 7.5, 7.0 Models

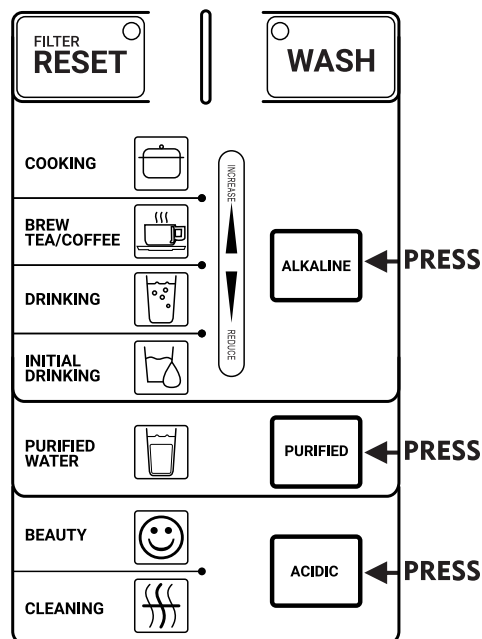

CLEANING FUNCTIONS

Automatic Cleaning

Whenever the water ionizer is in any of the 4 alkaline modes or either of the 2 acidic modes, ending water flow, either by turning off the faucet or faucet diverter valve will cause your water ionizer to reverse electroplate polarity and start the automatic cleaning process. This process lasts approximately 10 seconds while the screen lights up red and the “Washing” icon appears.



Enhanced Cleaning

- A. In addition to the auto-cleaning function that's initiated just before the unit enters standby mode after dispensing alkaline or acidic water, your water ionizer also has an extended Enhanced Cleaning function designed to help reduce the buildup of calcium, magnesium, and other chemical and mineral deposits on the unit's electroplates. The Enhanced Cleaning function is triggered after approximately every 40 liters of water that have been dispensed.
- B. When enhanced cleaning is required, a flashing wash indicator light will appear on the unit's LCD. Note: The water indicator, which has a solid circle around it, is NOT the same as the washing indicator, which has dual broken line circles around it.
- C. When the wash indicator appears, turn on the faucet and faucet valve. As water begins to flow to the water ionizer, press the WASH button on the control panel to initiate enhanced cleaning.
- D. During enhanced cleaning, which will last approximately 30 seconds, the unit will play music, the LCD screen will turn red, and water will be expelled from the flexible metal spout and acidic water outlet tube/diverter. DO NOT Drink this water as it will be acidic.
- E. When the music finishes, enhanced cleaning is complete and the unit will reset to whatever the last selected preset was.
- F. NEVER unplug the unit or attempt to carry out other water ionizer functions while the unit is in enhanced cleaning mode. Doing so may damage your water ionizer.



FILTER REPLACEMENT & DESCALING

Descaling removes mineral deposits (scale), which inhibit the electrolysis process, from the surface of the electroplates. If your local source water is particularly high in mineral deposits and/or if routine pH testing reveals an increasingly wide variance from the preset values over time, you should descale your water ionizer.

! IMPORTANT

For Maintenance Videos Visit:
www.aquaionizerpro.com/pages/maintenance

SCAN WITH YOUR SMART PHONE



Follow these directions to manually clean and descale your unit:

1. With the water turned off to the ionizer and the unit in standby mode, unplug the ionizer from the electrical outlet.

2. Place the ionizer below the diverter adapter (such as in your sink basin). This ensures the solution soaks inside the machine and does not leak or run out the residual tubing. **NOTE:** If the ionizer is under the sink, keep it below the counter.

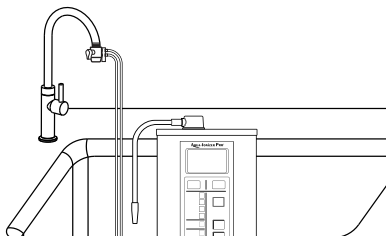

3. Remove the outer filter cover and the inner filter cover. Then remove and discard the inner filter. Dump out any excess water in the chamber.

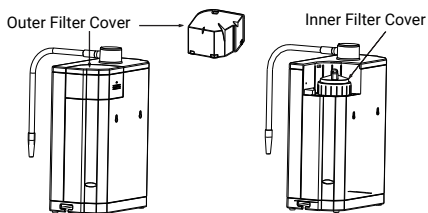

4. Fill a cup with about 2 cups of hot water (not boiling) and add the descaling powder to the water, then stir until the powder has fully dissolved.

5. Pour the descaling powder and water solution into the filter chamber until it's about $\frac{3}{4}$ inch from the top of the chamber.

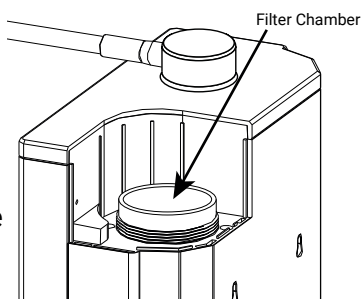

6. Reinstall the inner filter cover and let the solution soak for one to two hours.

FILTER REPLACEMENT & DESCALING

7. After soaking for at least one hour, turn on warm water to your faucet, and open the diverter valve to run water through the ionizer. Allow the water to rinse through the ionizer for 5 minutes to flush out any residual descaling solution.

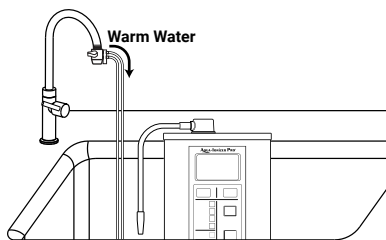

8. Turn the water off to the unit and unscrew the inner filter cover, dump out any excess water. Prime a new inner filter by holding it under running water for 3-5 minutes with the water going into the side with the 2 black o-rings, then insert the primed filter into the filter chamber.

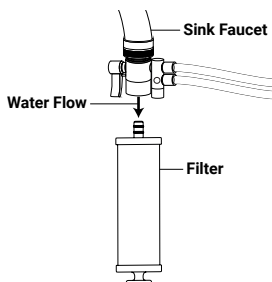

9. Replace the inner filter cover and outer filter cover and plug the ionizer back into power.

10. If you inserted a new inner filter, press and hold the Filter Reset button until the unit beeps (about 10 seconds). This resets the internal filter reminder, it will not change the liter count on the LED screen. You may now use your water ionizer normally.



↑
PRESS & HOLD

Questions?
(888) 601-5886

TROUBLESHOOTING

Problem	Solutions
LCD or Control Panel Functions aren't lit up.	Check that the power cord is plugged in and/or that the electrical outlet is functioning properly. Make sure water is flowing into/through the machine. Call: (888) 601-5886 for more help.
Water dispenses slowly or sputters.	Check hoses, valves, and connections to make sure they're not obstructed. Check to see if the water filter needs to be replaced. If you live in a cold climate, make sure neither your source water nor water in the unit has frozen.
Alkaline water output appears cloudy or milky.	This is generally a temporary anomaly caused by harmless, non-toxic hydrogen production as part of the electrolysis process. The cloudiness will disappear on its own after a few seconds and will not affect the taste of your drinking water. It can also happen because of extremely high levels of calcium and magnesium in your source water, aka hard water, when ionizing at higher pH levels. This is also harmless and will not affect the taste of your drinking water. You can reduce the instances in which the cloudiness occurs by either lowering the pH levels or increasing the water flow rate.
White particles begin to appear in your alkaline water and/or on the walls of the filter chamber.	Hard water, high in calcium and magnesium, can cause this type of buildup. Though this buildup is harmless, you can reduce or eliminate them by following the descaling instructions.
The flow rate dispensed through the flexible metal spout begins to diminish over time.	Hard water, high in calcium and magnesium, can cause this type of buildup. Though this buildup is harmless, you can reduce or eliminate them by following the descaling instructions. You can also soak the flexible metal spout in the descaling solution to alleviate this problem.
The flow rate dispensed appears to slow down immediately after replacing the Inner Carbon Filter.	This indicates there may be some residual air trapped in the water filter. Turning your faucet on high and allowing water to flow through the ionizer at a high flow rate for about 3-4 minutes will usually solve this problem.
Acidic water continues to drip from the acidic water outlet for 10 to 20 seconds after dispensing alkaline water.	This is a normal function. The excess acidic water is "divided" from the alkaline water as part of the ionization process and then expelled through the outlet hose.
Unit is very slow producing little to no water.	The water pressure may be too low. Turn your faucet on high and fully open the faucet diverter valve to increase the pressure. If this doesn't correct the problem, check to make sure the water filter isn't blocked.
Acidic water seems to have an unusual odor.	DO NOT DRINK - This acidic water smell is a normal byproduct of electrolysis reacting with the chlorine in the water.

TROUBLESHOOTING

Problem	Solutions
pH testing results is higher OR lower than factory defined ranges.	If the pH is somewhat higher than normal, it's generally normal following installing a new inner carbon filter. Generally the pH will settle back into the normal range within a week of installing the new filter. If the pH is slightly lower than normal, descaling the unit will usually fix this problem. If the pH variance is more extreme, you may want to move up or down to the next preset level to achieve the desired pH level.
After replacing the inner carbon filter the unit continues to prompt replacement of filter.	After replacing the filter, you must press and hold the Filter Reset button for at least 10 seconds to clear the prompt. See page 21 for more information.
After replacing the inner carbon filter, fine black particles appear in water.	These particles are harmless non-toxic carbon residue from the inner water filter. This generally occurs when you don't flush the filter under tap water for a few minutes prior to installation. Simply run water through the water ionizer for a few minutes until the particles disappear.
pH range is too low. Such as 7.0 to 8.0 pH on the cooking setting.	Your water may not have enough minerals for the ionizer to function properly. Use the included mineral filter instead of the carbon filter. Also see page 20 & 22 for more information.

Any other questions or concerns?

Call Us: (888) 601-5886

Or email us: Help@RealSpiritUSA.com

WARRANTY

Limited Lifetime Warranty

Aqua-Ionizer Pro® and its parent company, Real Spirit USA, Inc., offer a Limited Lifetime warranty on all its water ionizers to the original consumer purchaser under the following terms and conditions:

Aqua Ionizer Pro®, Aqua Ionizer Deluxe® 5.0 and Deluxe 7.0 models; a) For the first 5 years from the date of original purchase, we warrant the unit to be free from defects in materials and workmanship under normal operation (not including wear and tear use), we will repair or replace any defective part(s) or, at our discretion, replace the entire unit free of charge. b) After the first 5 years, we continue to stand behind your purchase for as long as you own it. Should the unit need to be repaired, we will provide the replacement parts at no charge to you. You will be responsible only for the cost of labor to replace the parts. Third party or reseller purchases are excluded from all warranties. Should the estimated cost to repair the unit exceed 30 percent (30%) of the unit's original suggested retail price, we will provide you the customer with an entirely new replacement unit of equal or greater original value for 30 percent (30%) of the current suggested retail price.

VIP Lifetime (NO TIME LIMIT) Warranty

By purchasing the Aqua Ionizer Deluxe® 7.5, 9.0, 9.5 Water Ionizer, your warranty period is extended beyond the 'Limited Lifetime Warranty' to a 'No Time Limit Warranty' on parts and labor or a full unit replacement should your Aqua Ionizer Pro®/Deluxe® 7.5/9.0/9.5 fail at any time now or in the future while in use by the original purchaser.

Whether in the first 5 years or subsequently, upon discovery of a product defect, you should immediately notify Real Spirit USA, Inc via telephone or email the exact problem you are having to the best of your knowledge. If it is determined to need additional diagnostic inspection, then we will provide you a product return authorization and shipping instructions. You should ship or deliver the product to the designated service location, accompanied by your name, address and telephone number, proof of purchase date and a description of the defect. The customer is responsible for the cost of shipping the unit to the service facility. Third party or reseller purchases are excluded from all warranties. However, following repair or replacement, Aqua Ionizer Pro will cover the cost of shipping the unit back to the consumer within the contiguous United States. Customers outside the contiguous United States must also cover the cost of return shipping following repair or replacement.

The warranty does NOT cover or include unusual wear, use of 3rd party equipment, damage resulting from accident or unreasonable use, failure to use the correct water supply or follow cleaning procedures as outlined in the owner's manual, and also does not include replacement filters nor other disposable parts and supplies (Examples are a cracked screen, broken swivel spout, cut power cord etc.). *Unreasonable use also includes using the unit outside of North America and in countries where the voltage may be higher than 110/120 Volts, which is the normal operating range of our products. **Additionally the warranty will become VOID should the case seal be broken and the tamper system activated which shall indicate the unit cabinet was opened for purposes other than authorized by the company. It should be noted that any electronic unit should be serviced only by an authorized service technician duly certified by Real Spirit USA, Inc. All warranties are non-transferable and remain registered to the original purchaser.

**Note: Please contact us for special 220/240 volt international models which may be available for use outside of North America.

**This warranty and return policy may be updated or amended at any time.
Please visit our website for the most up-to-date information.

RETURN POLICY & DAMAGE LIABILITY WAIVER

Return Policy

In order to receive a FULL REFUND (excluding rush shipping) you must contact our Sales and Customer Service department and return the items within our 30-Day satisfaction period from date of purchase. You can request a RA# to return all items to Real Spirit USA 320 S Rock blvd Ste 210 Reno NV 89502 within 30 days of ordering your product. Upon receipt of your complete original order you will receive a full refund (minus rush shipping if any, or used consumables such as filters in some cases, please discuss with your customer service specialist for additional details). Note: Outside of this 30 day period some additional reasonable charges may apply. Ultimately, your satisfaction is our goal.

Water Damage Liability Statement and Waiver

Aqua Ionizer Pro® water ionizers and filters are covered by our Limited Lifetime Warranty* or our VIP Warranty*. Aqua-Ionizer Pro® or its parent company Real Spirit USA, Inc accepts no liability, nor offers any warranty or remedy for damages of any kind in regard to water damage caused or reported to be caused by leaks from hoses, fittings or directly from any of our products.

Further, Aqua Ionizer Pro® does not warrant or accept any liability in regard to installing our Ionizer units, hoses, or additional valves or filters. Any such installation is at the sole responsibility of the owner or the third party installer, plumber or contractor.

The customer/user by purchasing our products accepts full responsibility for ensuring that the proper acceptable water pressure is present at the time of installation (as stated in the owner's manual). Water pressure is controlled by the supplier or the home owner and cannot be controlled or guaranteed by Aqua Ionizer Pro or its affiliates.

Once you have installed your unit, it is recommended that connections and connectors are inspected by the owner on a regular basis. It is also recommended that if you are away from the installation for longer than a 24 hour period that you turn off the water supply to your Water Ionizer system as well as turn off the supply power to your unit. This is a standard procedure for all home appliances connected to a water supply

Basic care and maintenance by the owner/user of this equipment is entirely the responsibility of the purchaser-owner/user, as Aqua Ionizer Pro assumes no responsibility for misuse, faulty installation, or variations in water pressure or quality. Other than what is expressed in our products warranty, Aqua Ionizer Pro assumes no additional liability for these foregoing statements or other 'Acts of God'.

By acceptance of delivery, and the installation the Aqua Ionizer Pro products (filters, ionizers, and accessories) you agree to hold Aqua Ionizer Pro and Real Spirit USA, Inc harmless for any water damage caused by leaking water or for any other reason.

*See warranty on previous page.

**This warranty and return policy may be updated or amended at any time.
Please visit our website for the most up-to-date information.

TECHNICAL SPECIFICATIONS

	Deluxe 9.5	Deluxe 9.0	Deluxe 7.5	Deluxe 7.0
Model Number	AID9500K	AID9000K	AID7500K	AID7000K
Plates	9	9	7	7
Plate Construction	Platinum-Coated Titanium Plates; Solid			
Power System	SMPS-Transformer Hybrid			
Voltage	AC 110V/60Hz			
Power	3W Idle / 380W* Operating			
Max. Operating Temp	140°F / 60°C			
Source Water Temp	41° - 140°F / 5°C - 60°C			
Operational Pressure	14.5 - 43.5 psi / 0.1 - 0.3 MPa			
Water Flow Rate	4 Liters per min (Adjustable)			
pH Levels	7 Total: 4 Alkaline, 1 Neutral, 2 Acidic			
Filter System	Activated Carbon Filter			
Filter Life	2000 L (Approx 6 Months to 1 Year with normal use.)			
Cleaning Cycles	2 Cycles (See pg. 26 for more info.)			
FDA Approved Plastics	Yes			
Dimensions	8.25 x 13 x 4.3 Inches (WxHxD)			
Weight	8 Lbs			
Warranty	Limited Lifetime Warranty			5 Year Limited

*Rated Power Consumption indicates the maximum power usage when the unit's "cooking" setting is engaged, ionized water pH output is constant and rated inflow, water temperature and total dissolved solids (TDS) are at their default value. The actual power consumption varies to maintain a constant pH depending on the inflow rate, water temperature and TDS.

AQUA-IONIZER PRO®

Questions?

(888) 601-5886

Made in Korea

Produced and distributed exclusively by:



REAL SPIRIT
an innovative products group

Aqua Ionizer Pro® is a division of Real Spirit USA, Inc.
320 South Rock Blvd Suite 210 • Reno NV 89502 • Ph (888) 601-5886
www.AqualonizerPro.com • help@realspiritusa.com

© 2024