









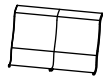

► **Safety and Care Advice**

- Please check and make sure you have all the parts indicated before you start with the assembly.
- Assembly work should be performed on a soft surface to prevent the finish to be scratched during assembly.
- Easy wipe clean with a dry or slightly damp cloth. Do NOT use chemical products.
- Please make sure there's no sharp objects (e.g. garden tools, knives and etc.) careful when sitting on the furniture for your own safety. Such items might tear down fabrics or pierce through resin weave, causing permanent damages.
- We recommend furniture to be covered or put away when not in use, in order to prolong product life.

► **Consejos de seguridad y cuidado**

- Antes de comenzar a ensamblar este producto, asegúrese de contar con todas las partes necesarias.
- Es conveniente ensamblar este producto sobre una superficie suave para no raspar el acabado.
- Límpielo con un paño seco o ligeramente húmedo. No utilice productos químicos.
- Debe tenerse cuidado al sentarse sobre el mueble con algún objeto cortante (herramientas de jardinería y cuchillos) en sus bolsillos, ya que pueden desgarrar las telas y penetrar el tejido de resina, lo que lo dañará irreparablemente
- Recomendamos guardar los muebles cuando no estén en uso para prolongar su vida útil

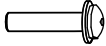
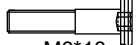
ASSEMBLY INSTRUCTIONS

Part #	Reference Image	QTY
A		1
B		1
C		1
D		1
E		1
F		1
G	 M6*15	7
H	 M6*30	6
I	 M6*18 Countersunk Bolt	4
J		4
K		1

STEP 1

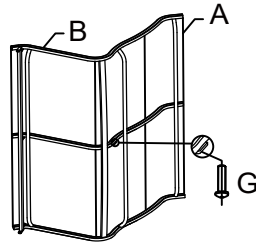

Screw chair back (A) to seat board (B). M6*15 bolts (G) are used. Please tight screws to the end.

STEP 2

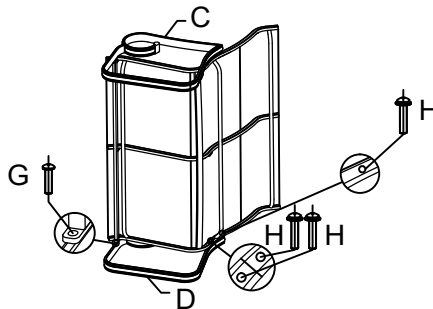

Screw chair armrest (C and D) to chair back (A) and seat board (B). M6*15 bolts (G) and M6*30 (H) are used. Please do not tighten screws to the end at this step.

STEP 3

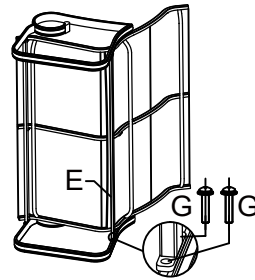

Place chair support beam (E) in the between of chair armrests properly and screw it. M6*15 bolts (G) are used. Please do not tighten any screws to the end at this step.

STEP 4

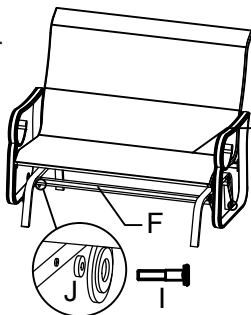

Stick the hook & loop velcro of backrest and seat board.

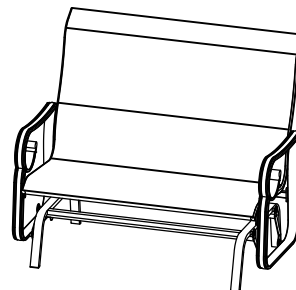

Finish and enjoy your chair.

Connect chair gliding base (F) to armrests with washers (J) and M6*18 countersunk bolts (I).

Make sure all bolts are connected properly, then tighten all screws to the end.

ASSEMBLY TIPS: Please use the hardware and accessories included in the set. DO NOT use other electrical or manual tools.

In order to facilitate the assembly and make your final product firm and stable, please tighten by a few rounds each screw one by one.

The assembly requires minimal level of DIY skills if you follow the instructions carefully. In case you encounter any difficulty or have any questions, feel free to contact the store or manufacturer.

ASSEMBLY INSTRUCTIONS

Part #	Reference Image	QTY
M		1
N		4
O		1
G	 M6*15	8
L	 M6*25	4
K		1

STEP 1

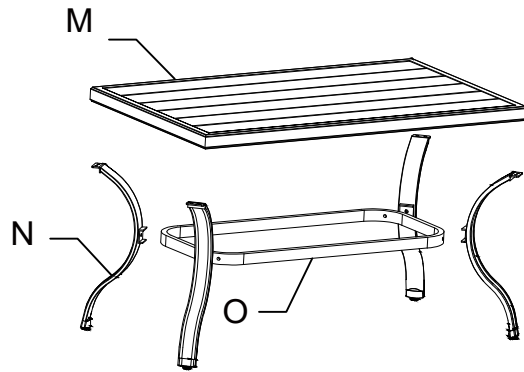

STEP 2

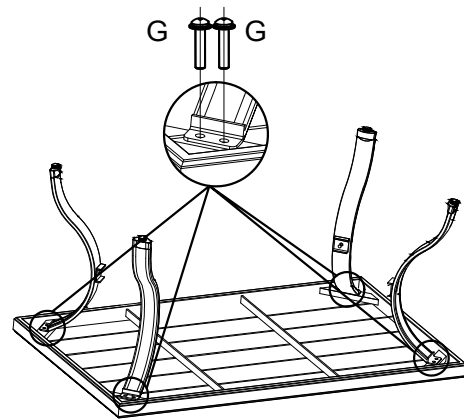

Place table board (M) on the flat ground.
Connect table leg (N) with it.
M6*15 bolts (G) are used.
Please do not tighten bolts to the end at this step.

STEP 3

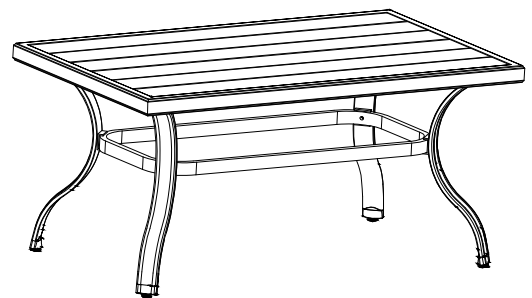
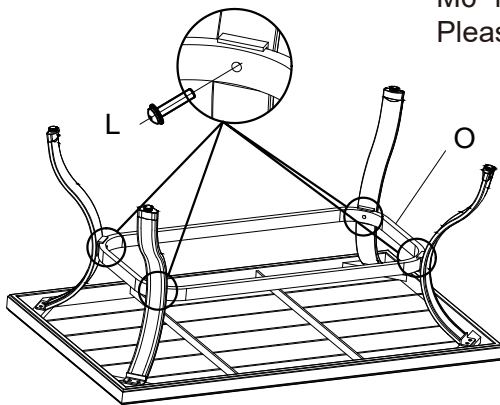

Finish and enjoy your table.

Connect table leg support ring (O) to table legs (N).
M6*25 bolts (L) are used. Please make sure all bolts are inserted and connected properly.
Then, tighten all bolts to the end.

ASSEMBLY TIPS: Please use the hardware and accessories included in the set. DO NOT use other electrical or manual tools.

In order to facilitate the assembly and make your final product firm and stable, please tighten by a few rounds each screw one by one.

The assembly requires minimal level of DIY skills if you follow the instructions carefully. In case you encounter any difficulty or have any questions, feel free to contact the store or manufacturer.