

# Table Assembly Instruction

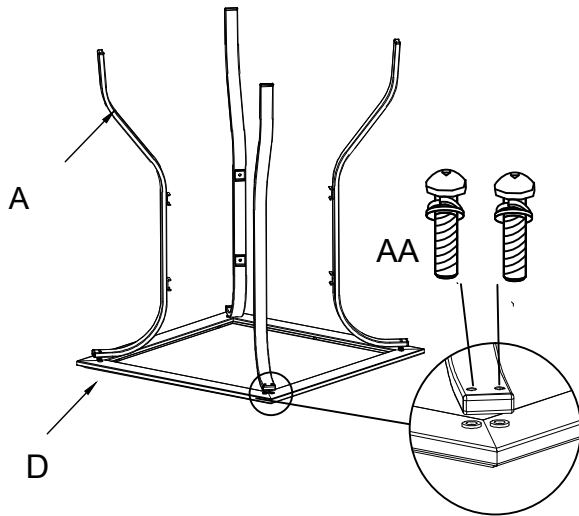



PF18265

Please DO NOT tighten any screw to the end before you've connected all screws.

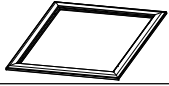

**Fig.1**

Step 1: Place the table frame (D) upside down on a soft surface. Line up the bolt holes on the table frame (D) with the corresponding bolt holes on the table legs (A). Insert M6x25 bolts (AA) and loosely tighten all bolts with allen wrench (BB). Please see Fig. 1.

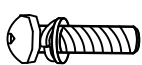
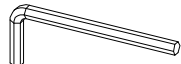
	PART LIST	DESCRIPTION	QTY
A		Table Leg	4
B		Connecting Frame	1
C		Connecting Frame	1
D		Table Frame	1
E		Glass	1
AA		M6x25 Bolt	16
BB		Allen Wrench	1

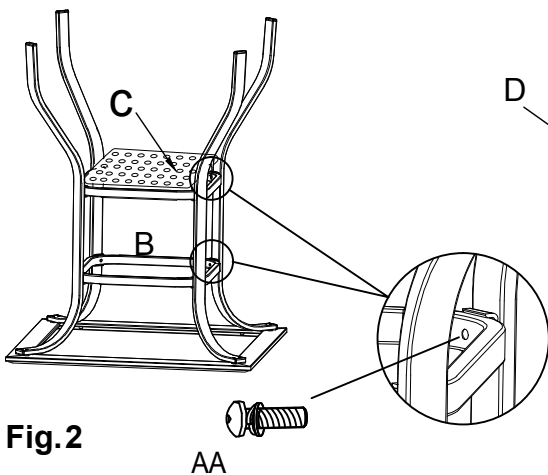

**Fig.2**

Step 2: Place the connecting frame (B&C) between the four legs (A). Line up the bolt holes on the connecting frame (B) with the corresponding bolt holes on the table legs (A). Insert M6x25 bolts (AA) and loosely tighten all bolts with allen wrench (BB). Please see Fig. 2.

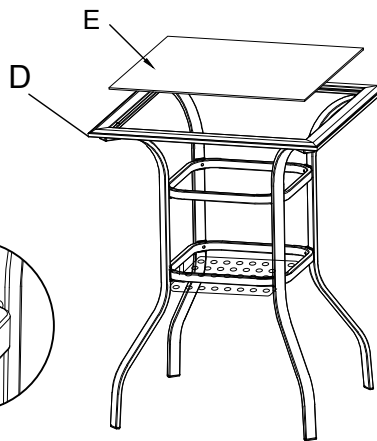

**Fig.3**

Step 3: Fully tighten all bolts and ensure all connections are secure before use. Turn the table right side up. Carefully place the glass (E) into the table frame (D). Please see Fig. 3.

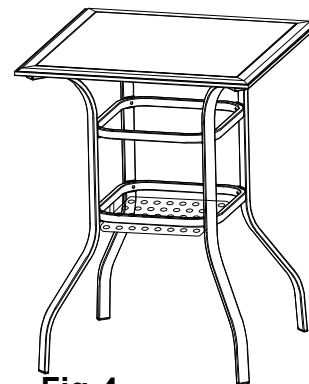

**Fig.4**

Step 4: Put the support shelf properly. Please see Fig. 4.