



PatioFestival









PLEASE READ CAREFULLY BEFORE ASSEMBLY.

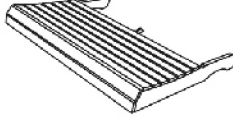

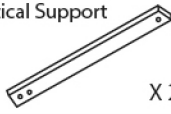
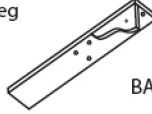
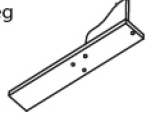
- Make sure that all parts and hardware are present before assembly.
- Assembly work should be performed on a soft and flat surface to avoid scratch during assembly.
- In order to facilitate the assembly and make your final product firm and stable, please tighten by a few rounds each screw one by one. After all screws are connected, then you start to tighten each screw to the end.

# DOUBLE CHAIR

ITEM# PF18223

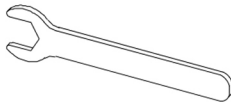

PARTS AND HARDWARE LIST		
(A)	(B)	
Seat Panel  X 1PC	Back Panel  X 1PC	
(C)	(DL)	(DR)
Back Vertical Support  X 2PCS	Left Leg  BACK	Right Leg 
(ER)	(EL)	(F)
Right Armrest  X 1PC	Left Armrest  X 1PC	Front Support Beam  X 1PC
(G)	(H)	(I)
 (φ6x50mm) Nut & Bolt X 14PCS	 (φ6x80mm) Nut & Bolt X 2PCS	 (φ3.5x35mm) Screw X 12PCS

Tools required for assembly	
	Wrench
	Phillips Screwdriver

**STEP 1:** KEEP ALL NUTS AND BOLTS LOOSE DURING ASSEMBLY

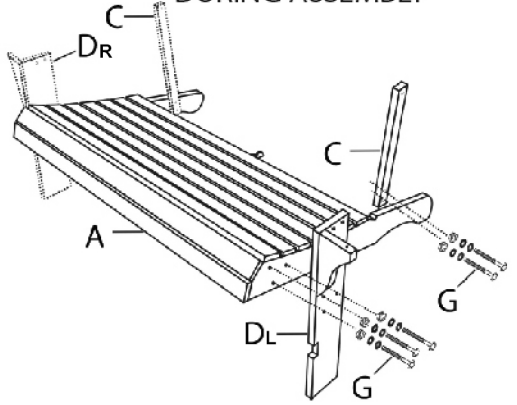

**STEP 2:**

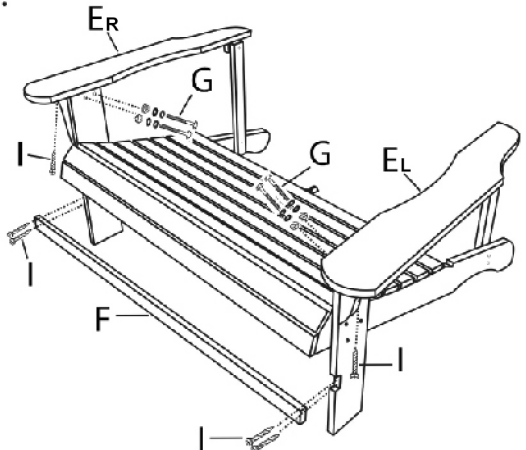

**STEP 3:**

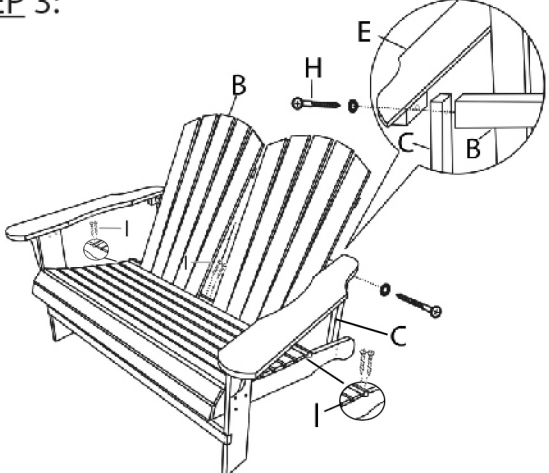

**STEP 4: Finish**



TIGHTEN ALL NUTS, BOLTS, & SCREWS LAST

Congratulations on your assembly!