



# ALUMINIUM BALUSTRADE SYSTEMS

## What you'll find inside

Visor™ balustrade

Barr balustrade

AIRE™ balustrade

Horizontal Slat balustrade

Premium Perf balustrade

v4



# The essentials.

PAGE **3**  
**Overview**

PAGE **4**  
**Visor™ Balustrade**

PAGE **46**  
**BARR Balustrade**

PAGE **60**  
**AIRE™ Balustrade**

PAGE **84**  
**Horizontal Slat  
Balustrade**

PAGE **104**  
**Premium Perf  
Balustrade**



Due to space restrictions,  
not all stock featured in  
this catalogue is stocked  
at all depots.

We recommend touching  
base with your closest  
depot prior to order  
placement if unsure.



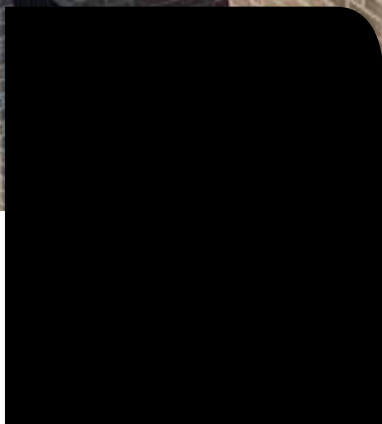

FLAT MATT BLACK / YN21BA (B)  
*Interpon D2525 powder coat*

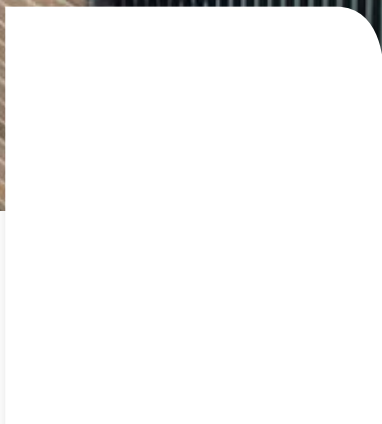

PEARL WHITE MATT / YA278A (W)  
*Interpon D2525 powder coat*



MILL (M)  
*Ready to powder coat*

*Note: Colours displayed are a guide only*



# INTRODUCING VISOR™

---

**We are proud to introduce a new architecturally inspired balustrade system Visor™ – where no welding is required! This stunning new balustrade system incorporates innovative and unique features, blending functionality, safety, and aesthetic appeal. The modern and highly stylish Visor™ uses 50mm x 10mm vertical balusters with 90mm spacings and is available in Matt Black, Pearl Matt White or Mill finish.**

Visor™ reflects a clean, minimalist design with streamlined profiles and simple geometric shapes. This design approach focuses on simplicity and elegance.

Visor™ not only provides a safe and functional balustrade system, but also contributes to the overall design and aesthetics of a space. The system can be tailored to suit different architectural styles, from modern and contemporary to traditional and ornate.

The system features face-mount and deck mount applications. Visor™ allows for a continual run of 50mm x 10mm balusters without the need for vertical posts to secure handrail and balusters.

When designing a modern balustrade system, it's important to consider the overall architectural style and ensure that the balustrade harmonises with the surrounding environment. Visor™ is a functional and visually stunning modern balustrade solution.

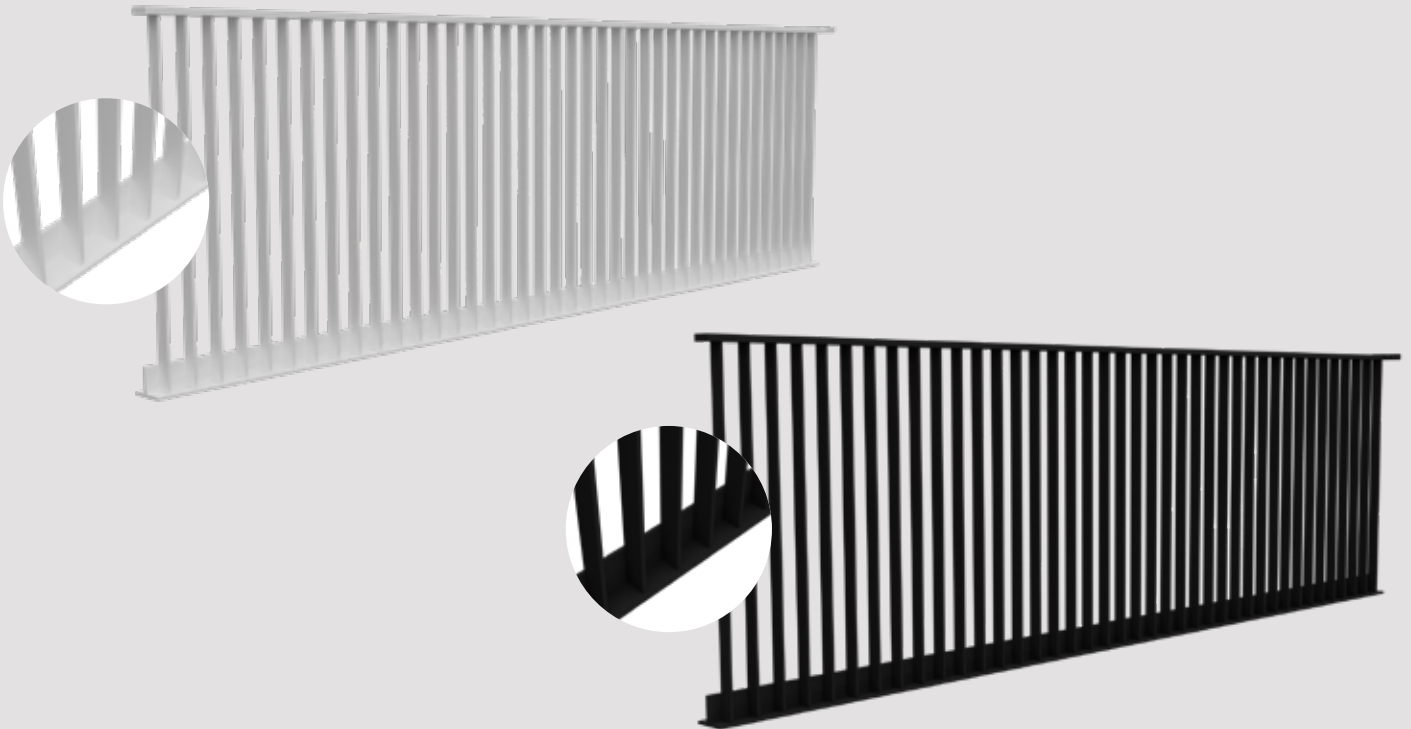



---

## Why choose Visor™?

Modern balustrade systems are known for their sleek, clean lines and contemporary design elements. They can enhance the overall visual appeal of a space, adding a touch of sophistication and elegance. Visor™ can become a focal point, complementing the architectural style and creating a sense of modernity.





# BENEFITS OF ALUMINIUM

---



## RECYCLABLE

Visor™ is made from aluminium – the most abundant metal in the Earth's crust and third most abundant element (after oxygen and silicon).



## NON COMBUSTIBLE

Aluminium is described as non-combustible. When aluminium is exposed to a prolonged fire environment it will begin to melt (not burn) with a melting point between 600 and 660 degrees celsius. Aluminium is an excellent choice where fire risk requires consideration.



## CORROSION RESISTANT

Aluminium is impervious to insects and termites plus the non-porous surface is naturally resistant to fungi, mould and mildew. It is also unaffected by exposure to sunlight and water making it ideal for balustrade solutions.

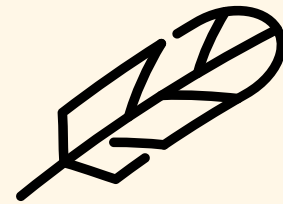

## LIGHT WEIGHT

Aluminium weighs approximately one third of a piece of steel that is the same size and shape. The Visor™ range is made by extruding aluminium which allows for optimisation of shape to maximise strength and reduce weight.



## DURABLE POWDER COAT

Powder coating aluminum provides outstanding long term colour fastness and stability.



## WIPE CLEAN

Enjoy minimal maintenance with Visor™ with the ease of a simple wipe/hose down clean.



# VISOR™ FACE MOUNT OVERVIEW

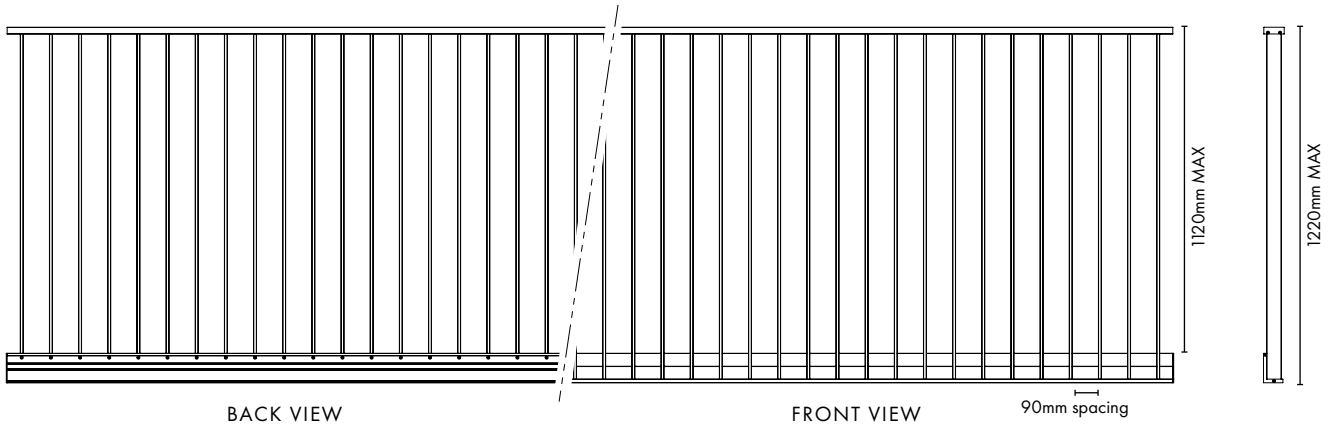

- 1 Handrail offset bracket
- 2 70x23mm rectangular handrail
- 3 70x23mm handrail end plate
- 4 8Gx25mm countersunk SS304 screw
- 5 14Gx50mm pan head SS304 screw
- 6 Handrail friction insert
- 7 Handrail under-capping plate (slotted)
- 8 50mm x 10mm baluster
- 9 Face-mount profile (pre-drilled)
- 10 Face-mount end plates
- 11 14Gx50mm pan head SS304 screw
- 12 12Gx50mm pan head SS304 screw
- 13 Face-mount bottom cover

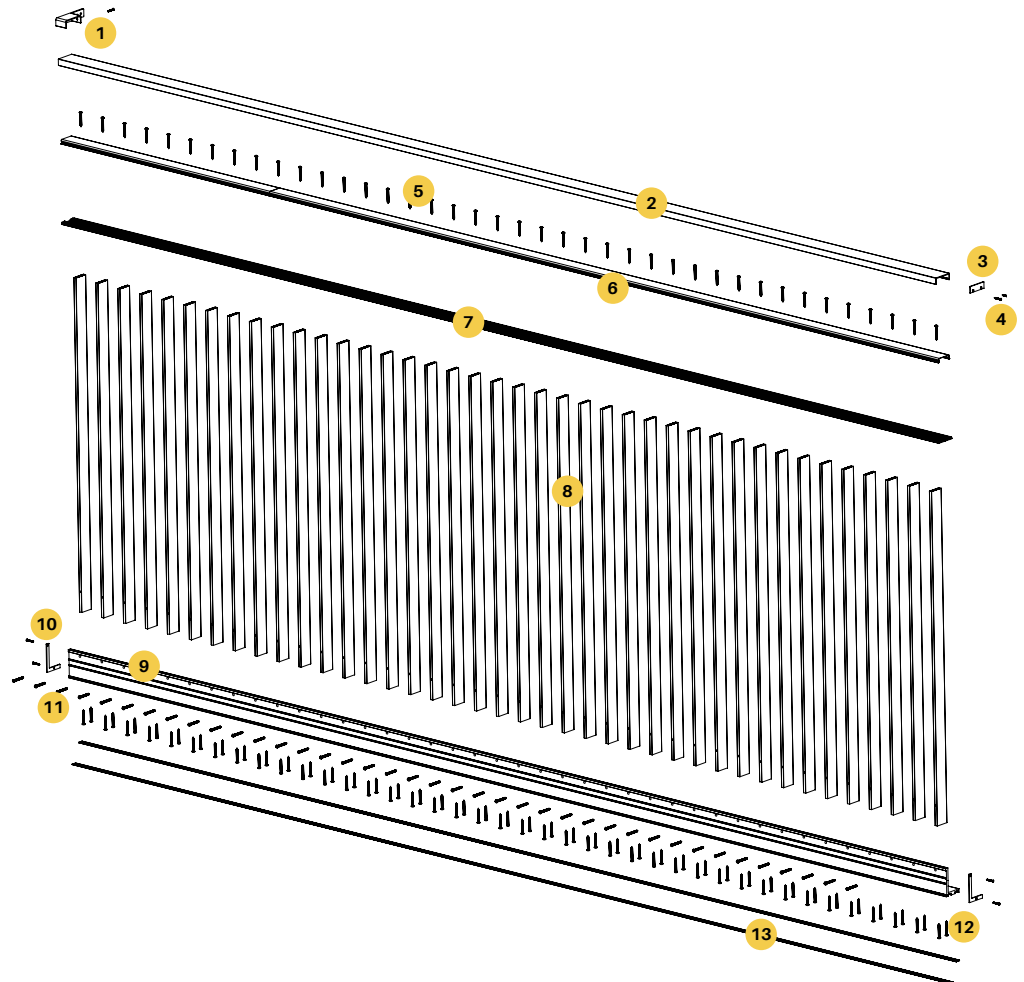





# VISOR™ DECK MOUNT OVERVIEW

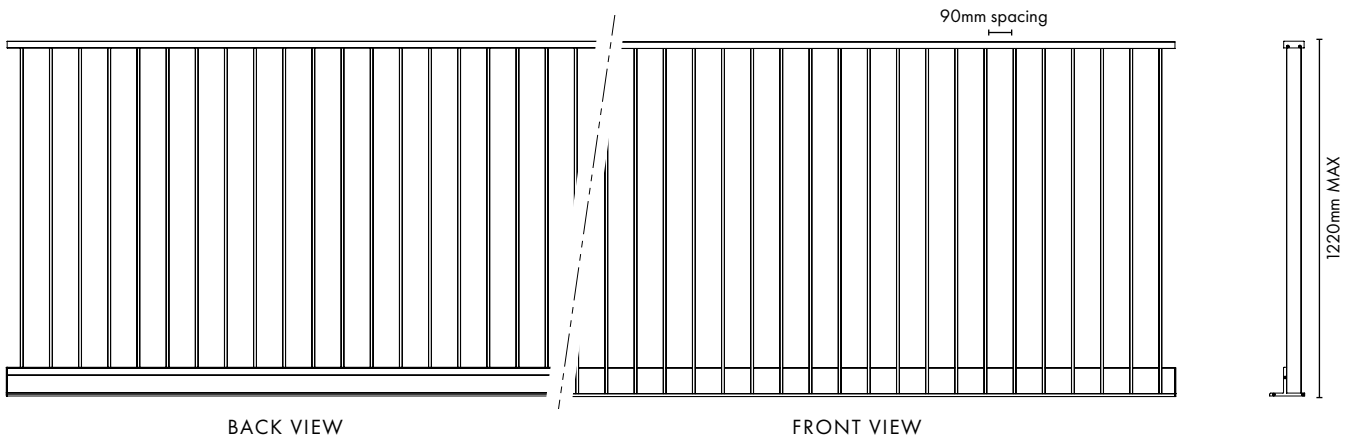

- 1 Handrail offset bracket
- 2 70x23mm rectangular handrail
- 3 70x23mm handrail end plate
- 4 8Gx25mm countersunk SS304 screw
- 5 14Gx50mm pan head SS304 screw
- 6 Handrail friction insert
- 7 Handrail under-capping plate (slotted)
- 8 50mm x 10mm baluster
- 9 Deck-mount profile (pre-drilled)
- 10 Deck-mount end plates
- 11 14Gx50mm pan head SS304 screw
- 12 12Gx50mm pan head SS304 screw
- 13 Deck-mount side cover

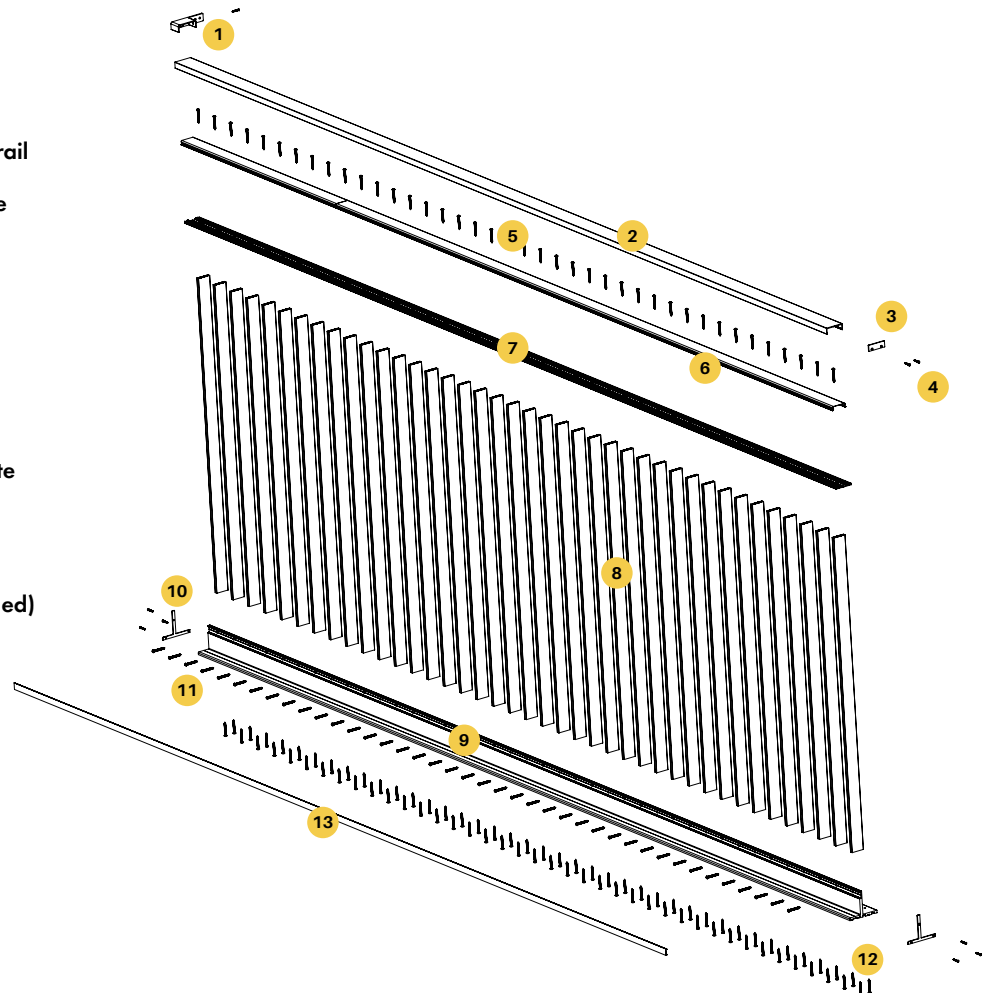



# VISOR™

## Aluminium 50x10mm baluster

PACK OF 4  
1200mm high

**Matt Black, Pearl White Matt or Mill finish**

Order Code: VIS-1200-BAL-B-4PK (Black)

VIS-1200-BAL-W-4PK (White)

VIS-1200-BAL-M-4PK (Mill)

- 1200mm long balusters: pack of 4
- Simply cut to required length if required
- Innovative baluster design:  
2 x screw flutes + rigidity ribs
- Each baluster has 1 x 6mm hole drilled 73.5mm up from bottom: hole enables fast sideways fixing off of baluster to Visor™ base
- Made from alloy 6063 T6

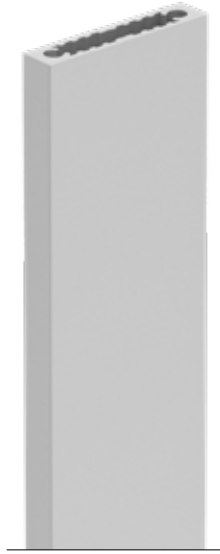

### FINISHES

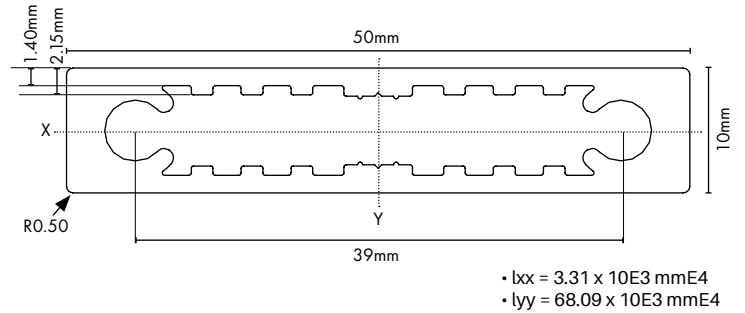

TOP

1200mm

BOTTOM

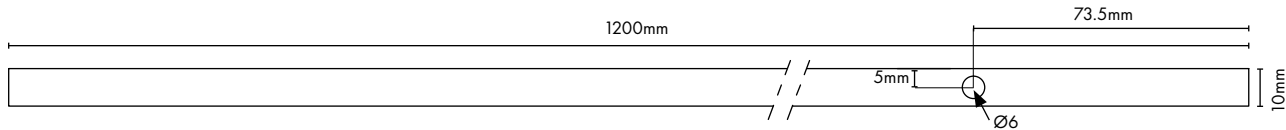

## Aluminium 50x10mm baluster

6100mm long

**Matt Black, Pearl White Matt or Mill finish**

Order Code: VIS-6100-BAL-B (Black)

VIS-6100-BAL-W (White)

VIS-6100-BAL-M (Mill)

- 6100mm long balusters
- Simply cut to required baluster lengths
- Innovative baluster design:  
2 x screw flutes + rigidity ribs
- Made from alloy 6063 T6

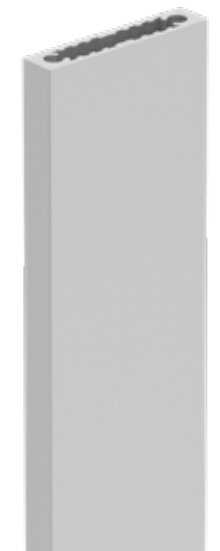

### FINISHES

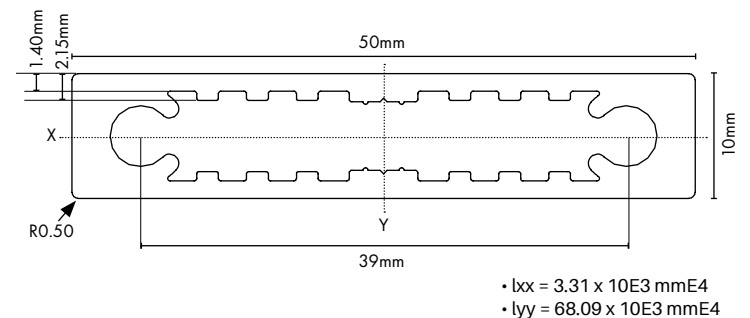

### TRADE TIP

Contact us for easy to use FREE EXCEL estimator. Simply input span lengths & receive instant bill of materials.



# VISOR™

## Aluminium deck mount 'T' profile

4000mm long

**Matt Black, Pearl White Matt or Mill finish**

Order Code: VIS-4000-DECK-B (Black)

VIS-4000-DECK-W (White)

VIS-4000-DECK-M (Mill)

- "T" profile deck mount base - 4000mm long
- Sturdy 10mm thick base with 10.5mm thick vertical profile
- Base fully machined to enable 50x10mm balusters to be screwed fixed at 100mm centres (providing 90mm gaps). 40 x balusters per length.
- Holes are pre-machined entire length of base to enable each baluster to receive 2 x fixings from underside & 1 x side fixing.
- 4000mm long screw fix cover extrusion included in kit: neatly hides top sideways screw fixings
- For fixing to substrate/floor, drill holes through deck mount profile where required (suggested at 500mm centres or less)
- Made from alloy 6063 T6

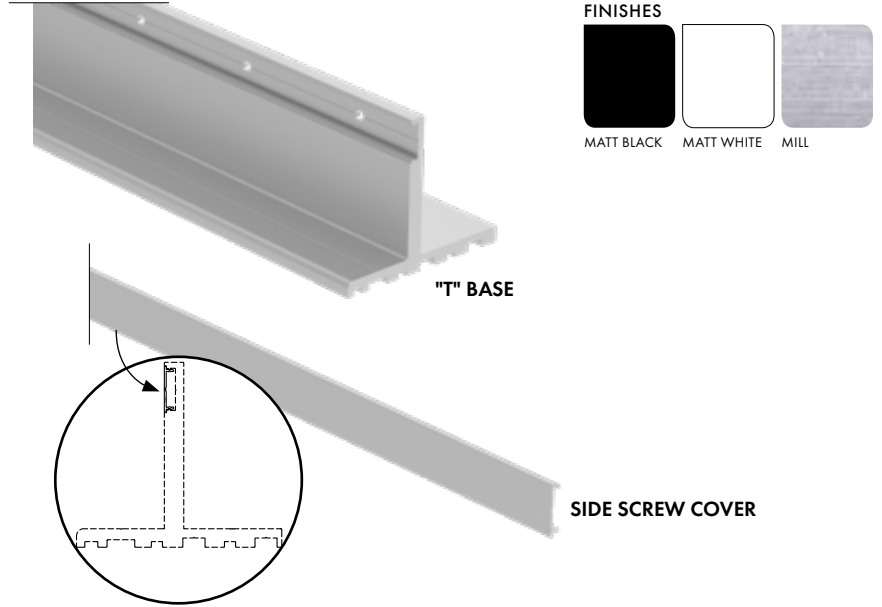

### TOP HOLE MACHINING

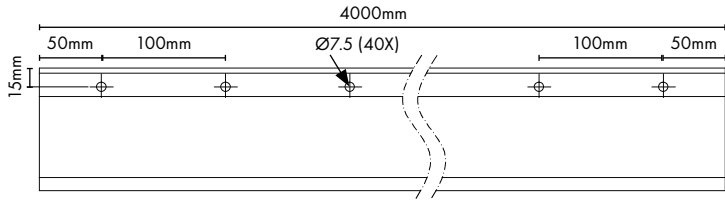

### UNDER SIDE BALUSTER MACHINING

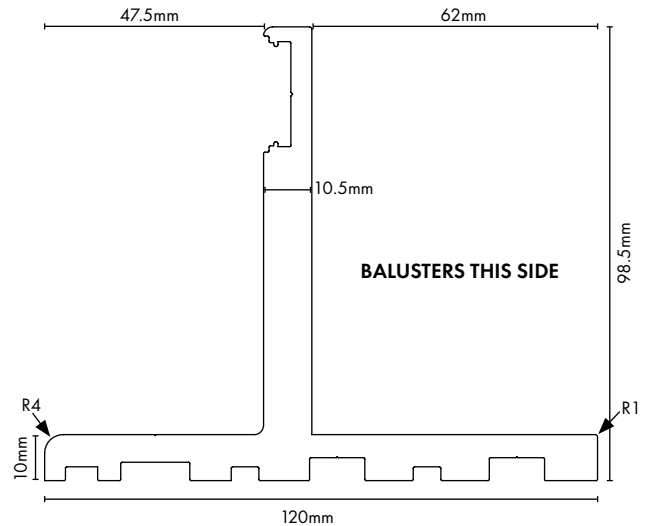
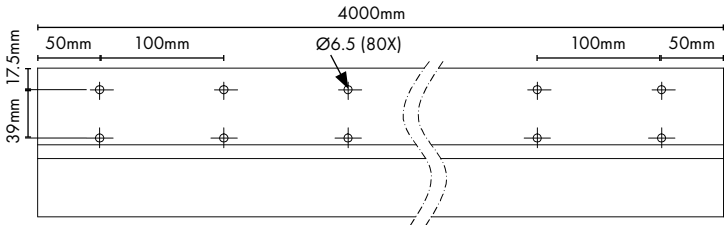

## Aluminium side cover

4000mm long

**Matt Black, Pearl White Matt or Mill finish**

Order Code: VIS-4000-COV-DECK-B (Black)

VIS-4000-COV-DECK-W (White)

VIS-4000-COV-DECK-M (Mill)

- 4000mm long screw fix cover extrusion: neatly hides top sideways screw fixings
- Tap cover into void opening
- Screw cover extrusion is INCLUDED with the deck mount profile
- Order separately only if needing to replace a lost/damaged screw cover extrusion

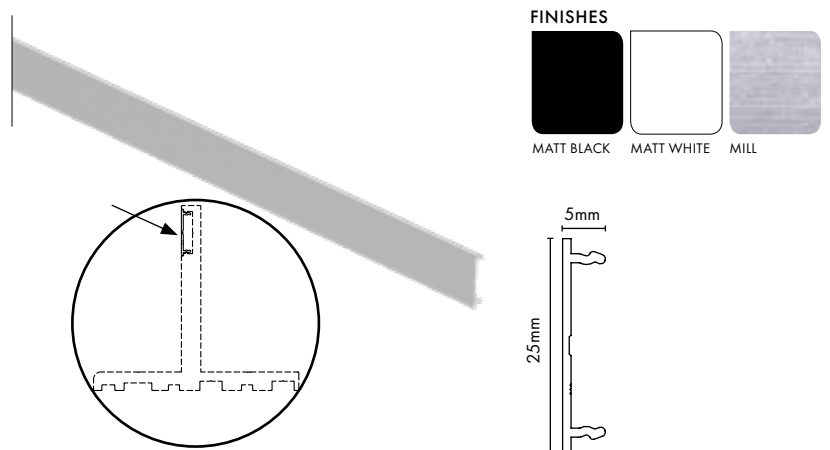



# VISOR™

## Aluminium face mount 'L' profile

4000mm long

**Matt Black, Pearl White Matt or Mill finish**

Order Code: **VIS-4000-FACE-B (Black)**

**VIS-4000-FACE-W (White)**

**VIS-4000-FACE-M (Mill)**

- "L" profile face mount base - 4000mm long
- Sturdy 12.5mm thick base with 11mm overall thick vertical profile
- Base is fully machined to enable 50x10mm balusters to be screwed fixed at 100mm centres (providing 90mm gaps). 40 x balusters per length.
- Holes are pre-machined entire length of base to enable each baluster to receive 2 x fixings from underside & 1 x side fixing.
- 2 x 4000mm long bottom screw fix cover extrusions included in kit: neatly hides bottom fixing screws
- For fixing to vertical surface, drill holes through face mount profile where required (suggested at 500mm centres or less)
- Made from alloy 6063 T6

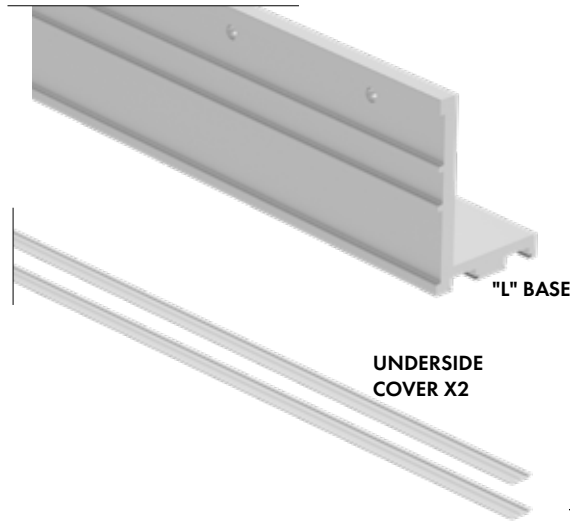

### FINISHES

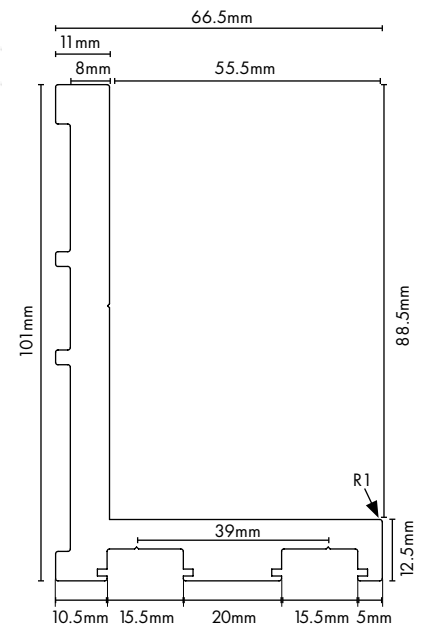
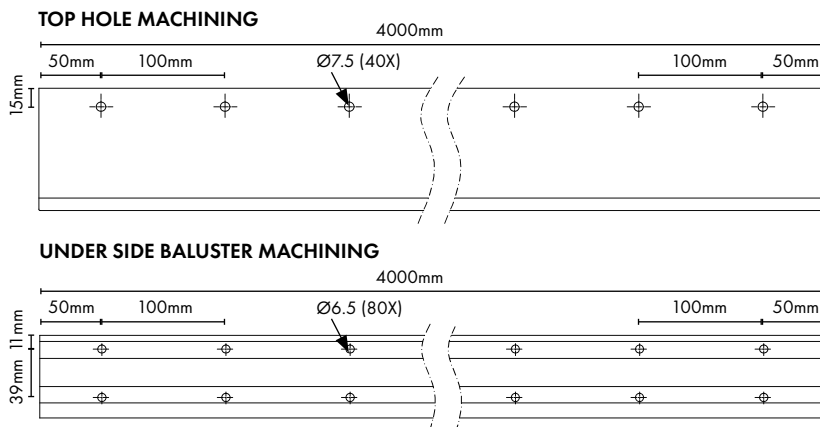

## Aluminium face mount 'L' profile

5000mm long

**Mill finish**

Order Code: **VIS-5000-FM-NM-M (Mill)**

- "L" profile face mount base - 5000mm long
- NO MACHINED holes - requires welding of 50x10mm balusters to profile
- Use for customised situations such as staircases
- Purchase bottom cover extrusion profile separately if desired (code: VIS-4000-COV-FACE)
- For top handrail, use RAKED undercapping plate which suits 34-37° installations (refer code: VIS-4942-PLATE-R)
- Made from alloy 6063 T6

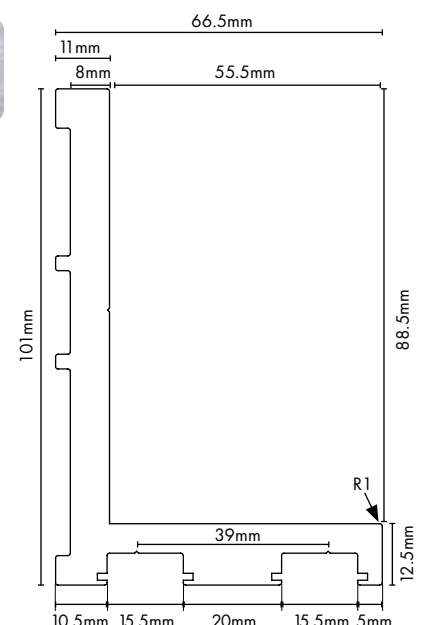
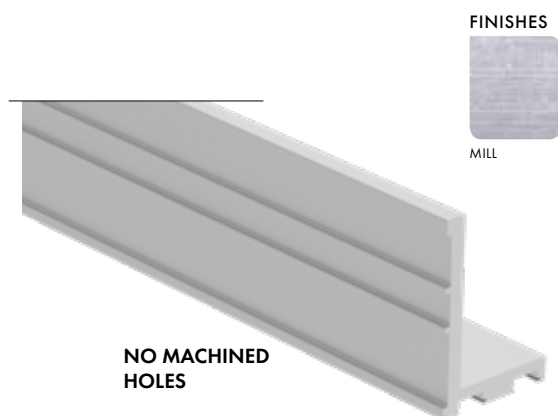



# VISOR™

## Aluminium bottom cover slide in

4000mm long

**Matt Black, Pearl White Matt or Mill finish**

Order Code: VIS-4000-COV-FACE-B (Black)

VIS-4000-COV-FACE-W (White)

VIS-4000-COV-FACE-M (Mill)

- 4000mm long screw fix cover extrusion: neatly hides bottom screw fixings
- Slide in cover into underside 2 x cavities in face mount profile
- NOTE: 2 x screw cover extrusions are INCLUDED with the face mount profile
- Order separately only if:
  - a) needing to replace a lost/damaged screw cover extrusion
  - b) using NON MACHINED face mount base and seeking to cover under side cavities

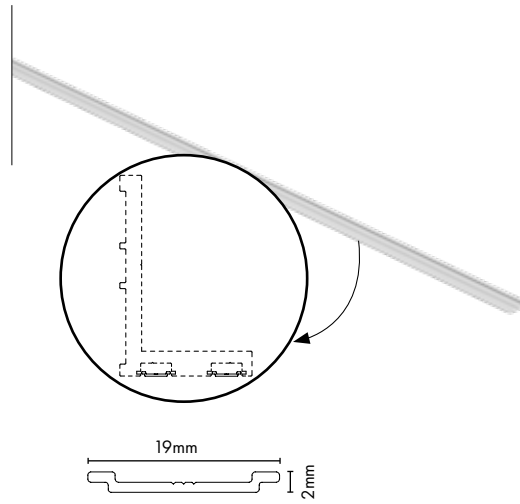

### FINISHES



MATT BLACK

MATT WHITE

MILL





# VISOR™

## Aluminium undercapping plate

4000mm long

**Matt Black, Pearl White Matt or Mill finish**

Order Code: VIS-4000-PLATE-B (Black)

VIS-4000-PLATE-W (White)

VIS-4000-PLATE-M (Mill)

- 4000mm long top undercapping plate
- 40 x pre-slotted holes at 100mm centres into which 50x10mm balusters insert
- 2.2mm plate thickness provide for a sturdy top undercapping plate
- Features 2 x screw flutes used for mechanical fixing of end caps & wall plates
- Made from alloy 6063 T6

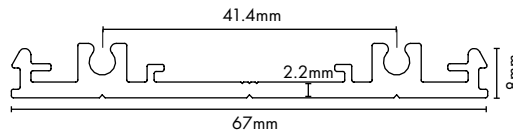
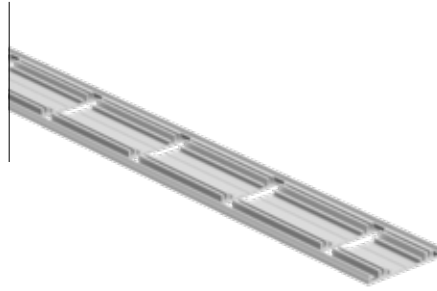

### FINISHES



### TOP PLATE MACHINING

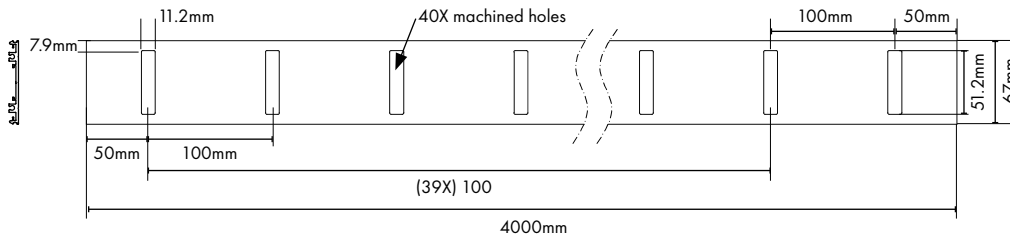

## Aluminium undercapping plate – raked

Suits 34-37 degree angle

4942mm long

**Matt Black, Pearl White Matt or Mill finish**

Order Code: VIS-4942-PLATE-R-B (Black)

VIS-4942-PLATE-R-W (White)

VIS-4942-PLATE-R-M (Mill)

- 4942mm long top undercapping plate to suit STAIR installations
- 39 x pre-slotted ELONGATED holes at 123.5mm centres into which 50x10mm balusters insert
- Suits 34-37 degree angle which satisfies the majority of stair installation requirements
- 2.2mm plate thickness provide for a sturdy undercapping plate
- Made from alloy 6063 T6



### FINISHES



### UNDERLAPPING PLATE RAKED MACHINING

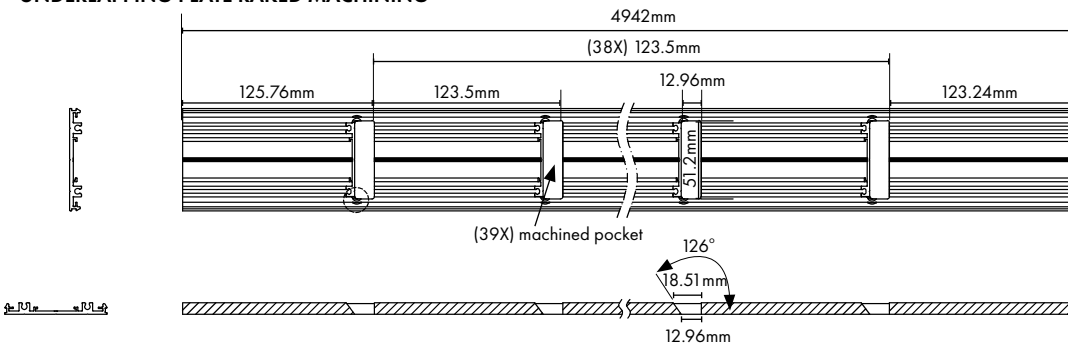



# VISOR™

## Aluminium friction insert

PACK OF 2

3050mm long (total 6100mm per 2 pack)

Clear Anodise finish

Order Code: VIS-3050-INS-2PK

- 3050mm long aluminium insert: 2 pcs per pack
- Mates with slotted undercapping plate
- 50x10mm balusters insert into assembled unit and balusters finish at the underside wall of the friction insert
- Innovate design means that balusters are held in place via friction fit both sides preventing chance of rattling handrail assembly

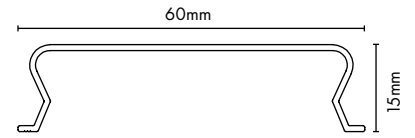
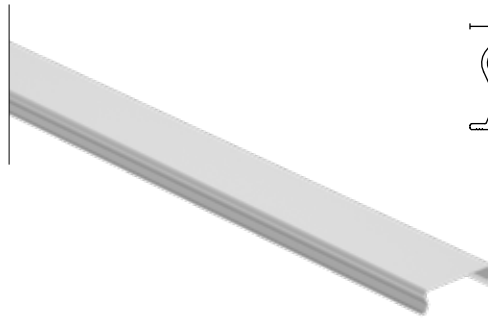

## Aluminium rectangular handrail – 70x23mm

6100mm long

Matt Black, Pearl White Matt or Mill finish

Order Code: VIS-6100-HRAIL-B (Black)

VIS-6100-HRAIL-W (White)

VIS-6100-HRAIL-M (Mill)

- 6100mm long snap-on slimline handrail: 70mm wide x 23mm high profile
- Mates with undercapping plate
- 2.8mm top wall thickness provide a sturdy/rigid top rail surface
- Made from Alloy 6063 T6

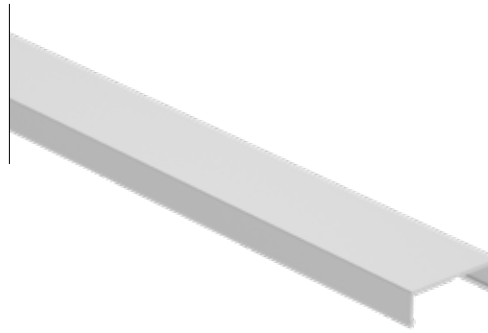

### FINISHES

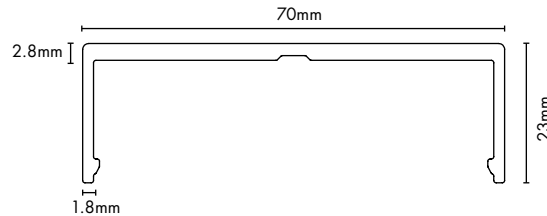

## OVERVIEW OF HANDRAIL ASSEMBLY

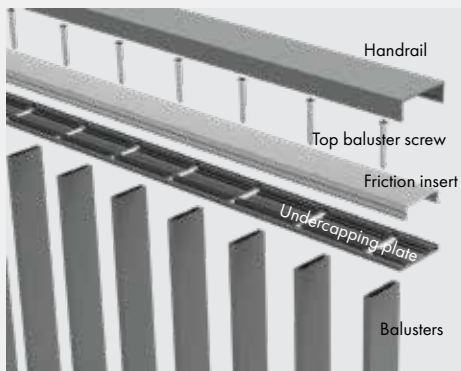

EXPLODED VIEW



ASSEMBLED VIEW



END VIEW

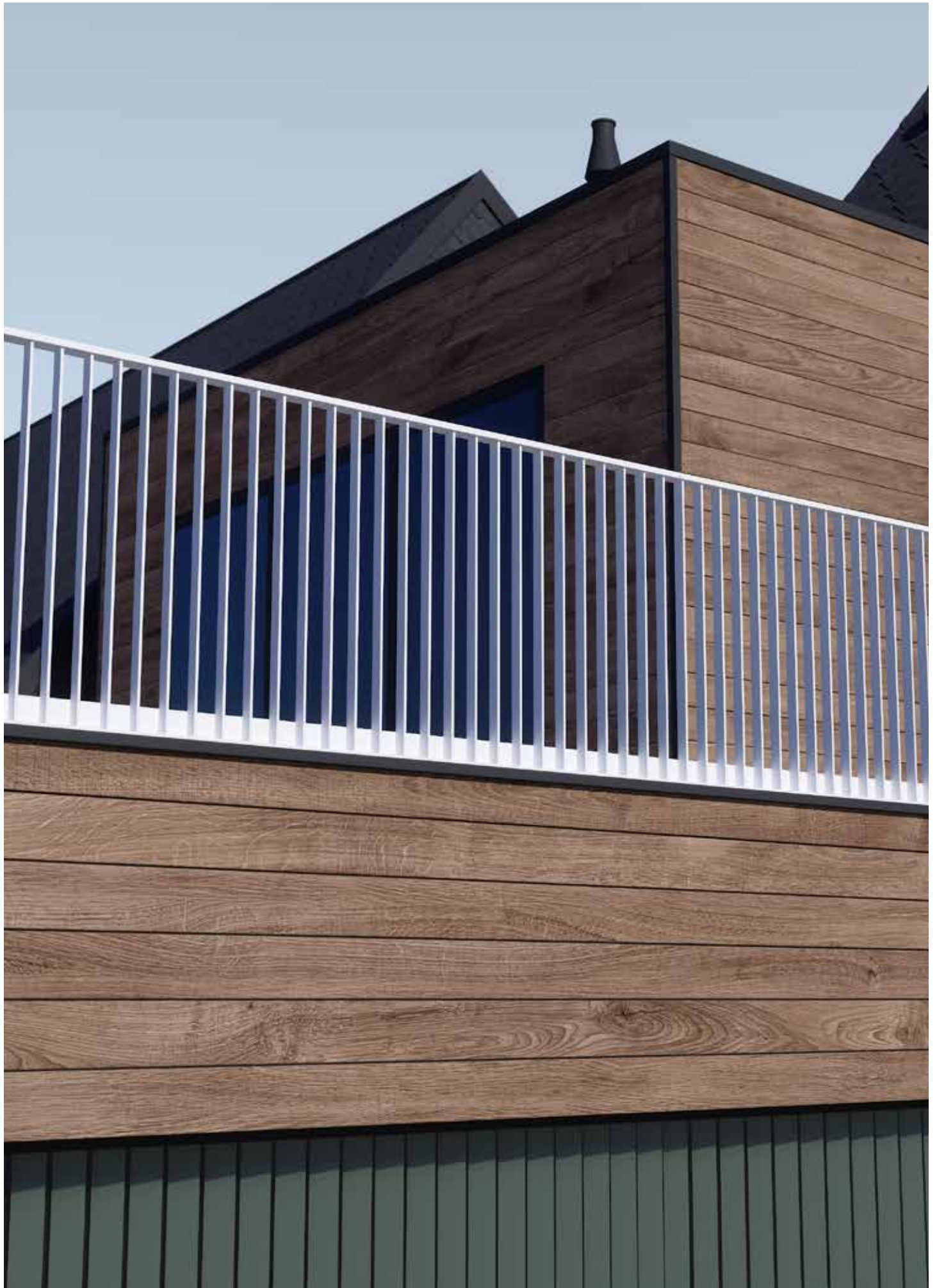





# VISOR™

## Aluminium offset bracket

2 PACK

140mm L x 28mm H x 45mm D

**Matt Black, Pearl White Matt or Mill finish**

Order Code: **VIS-BRACKET-B-2PK (Black)**

**VIS-BRACKET-W-2PK (White)**

**VIS-BRACKET-M-2PK (Mill)**

- Made from aluminium die cast
- Caps over top of handrail and features offset leg for fixing to wall/post
- Mechanically fix to handrail by screwing through side of bracket
- 2 x 7mm diameter post/wall fixing holes
- Fix to wall/post using suitable fixings (not supplied) having regard to substrate
- Sold as a 2 pack - 1 x left & 1 x right bracket

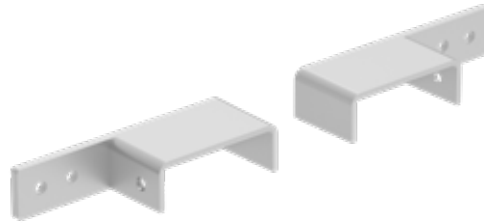

### FINISHES



MATT BLACK

MATT WHITE

MILL

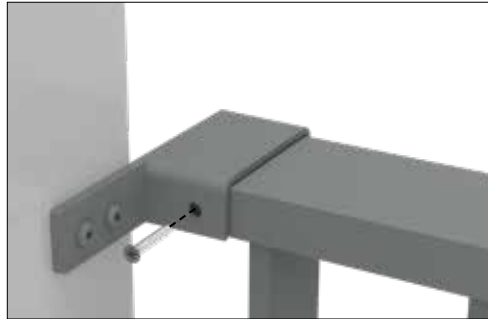
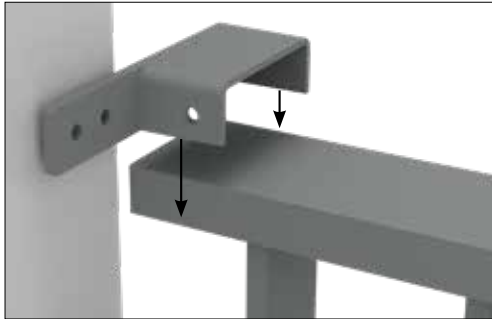
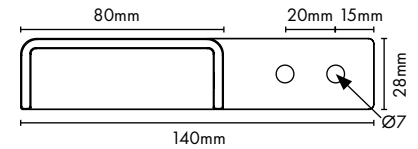



# VISOR™

## Aluminium 70x23mm handrail end plate

**Matt Black, Pearl White Matt or Mill finish**

Order Code: VIS-EP-B (Black)

VIS-EP-W (White)

VIS-EP-M (Mill)

- 70x23 end plate - 3mm thick
- Extruded aluminium with 2 x 5mm diam countersunk holes
- Mechanically fixes to undercapping plate
- Countersunk screws sold separately (refer code: VIS-SCR-CSK-50PK)

### FINISHES

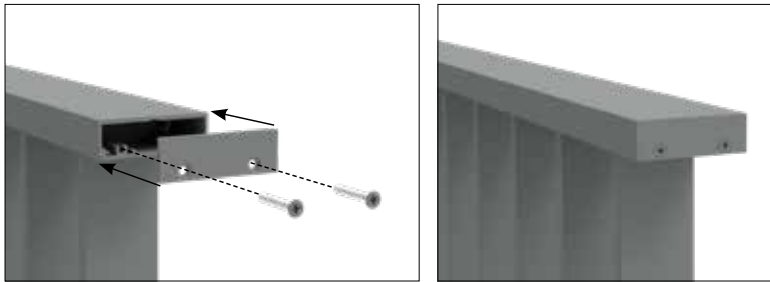
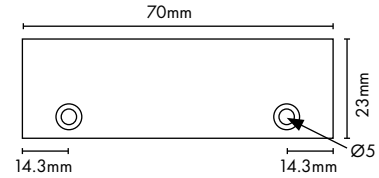
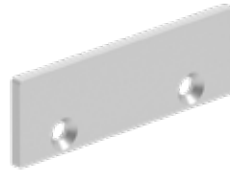

## Aluminium 63x20mm wall/post bracket

**Matt Black, Pearl White Matt or Mill finish**

Order Code: VIS-WB-B (Black)

VIS-WB-W (White)

VIS-WB-M (Mill)

- 63x20 wall plate - 8mm thick
- Extruded aluminium with 4 x 5.5mm diam countersunk holes
- Mechanically fixes to undercapping plate and then fix off to wall/post
- Once snapped on, 70x23mm handrail covers bracket giving a seamless terminating fixing
- Screws for fixing to undercapping rail sold separately (refer code: VIS-SCR-CSK-50PK)
- Screws for fixing to wall/post not supplied - determine having regard to substrate screwing into

### FINISHES

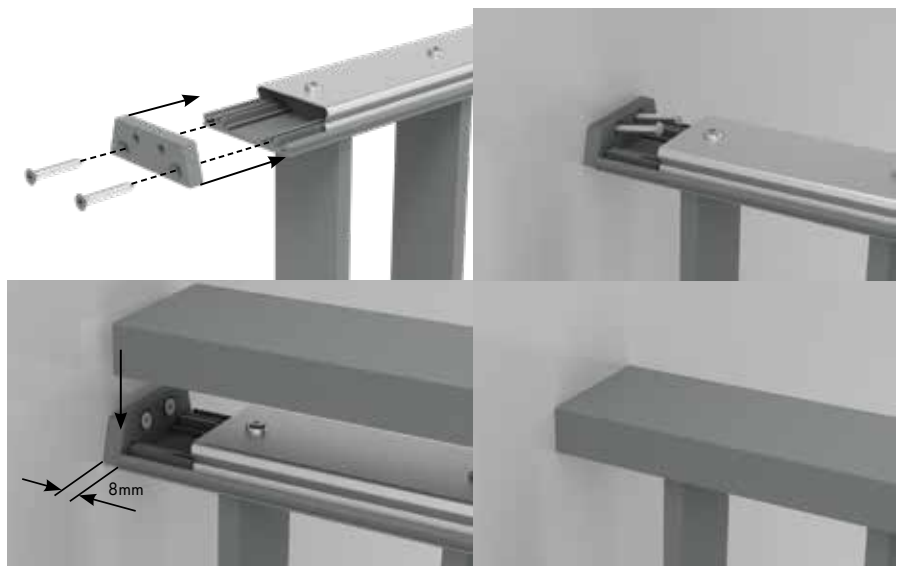
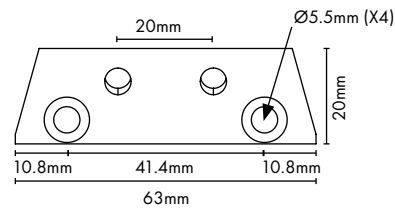
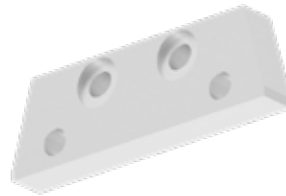



# VISOR™

## 'T' deck mount end plates

PACK OF 2

**Matt Black, Pearl White Matt or Mill finish**

Order Code: VIS-DMEP-B-2PK (Black)

VIS-DMEP-W-2PK (White)

VIS-DMEP-M-2PK (Mill)

- "T" shape end plates to suit deck mount base
- 3mm extruded aluminium with 3 x fixing holes
- Drill 3 x 3.5mm diam hole into end of deck mount base and fix end plates with 3.2mm diameter pop rivets (not supplied)
- Sold as a 2 pack: 1 x left & 1 x right end plate

### FINISHES

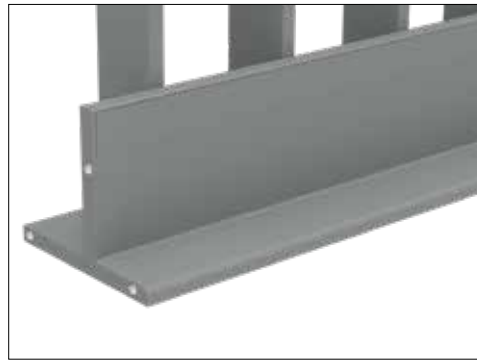
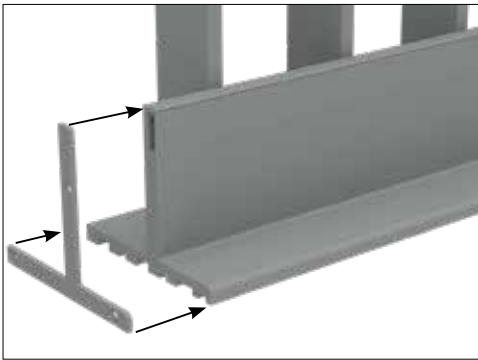
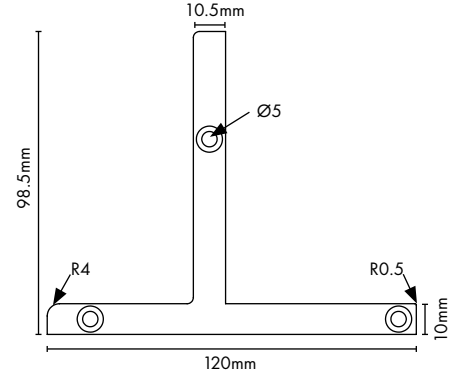
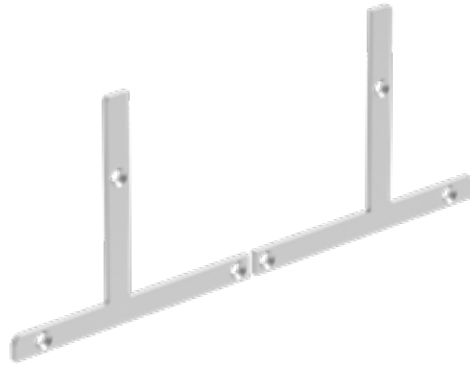

## 'L' face mount end plates

PACK OF 2

**Matt Black, Pearl White Matt or Mill finish**

Order Code: VIS-FMEP-B-2PK (Black)

VIS-FMEP-W-2PK (White)

VIS-FMEP-M-2PK (Mill)

- "L" shape end plates to suit face mount base
- 3mm extruded aluminium with 2 x fixing holes
- Drill 2 x 3.5mm diam hole into end of face mount base and fix end plates with 3.2mm diameter pop rivets (not supplied)
- Sold as a 2 pack: 1 x left & 1 x right end plate

### FINISHES

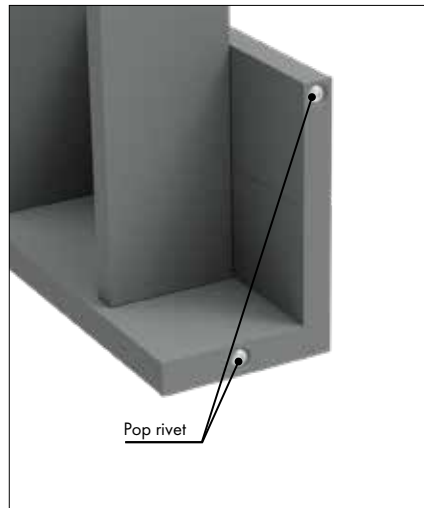
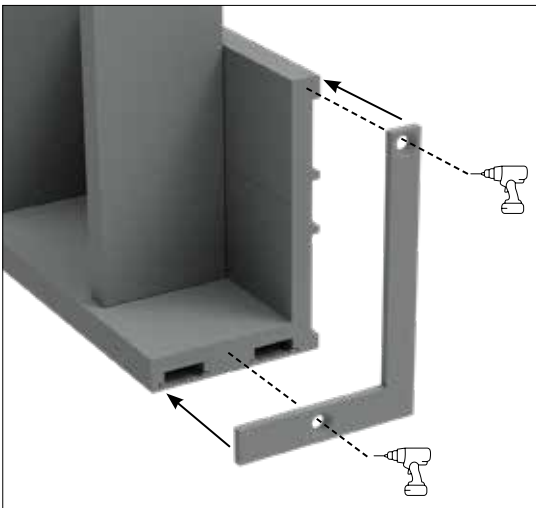
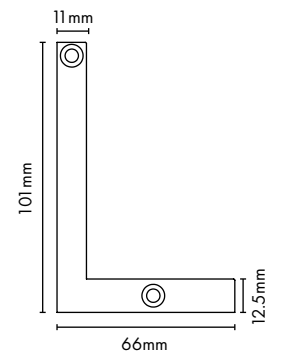
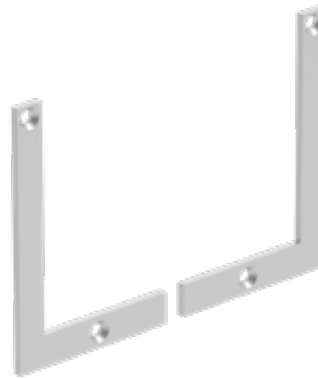



# VISOR™

## Aluminium inline joiner for handrail friction insert

400x40x1.2mm

### Mill finish

Order Code: VIS-J-M

- 400mm long aluminium joiner with 4 x 6.5mm diameter holes
- Use at join of uncapping plates
- Joiner fitted on top of friction insert
- Installed as a final step and just prior to snapping on rectangular handrail
- Joiner provides rigidity between adjacent panels

FINISHES



MILL

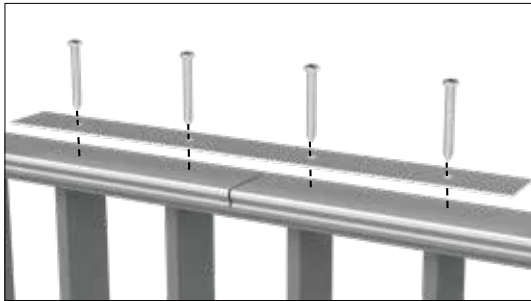
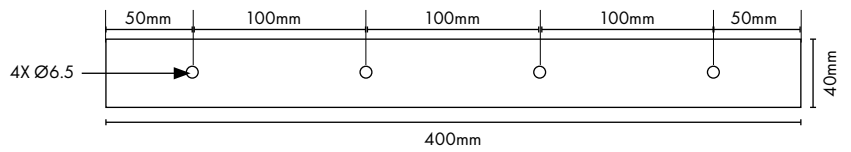

## Aluminium 90 degree joiner for handrail friction insert

200x200x1.2mm

### Mill finish

Order Code: VIS-J90-M

- 200 x 200mm long 90 degree aluminium joiner
- Use at 90 degree joins of uncapping rail
- Joiner fitted on top of friction insert
- Drill 4 x 7mm holes in joiner to align with central baluster screw flute positions
- Installed as a final step and just prior to snapping on rectangular handrail
- Joiner provides rigidity at 90 degree corner

FINISHES



MILL

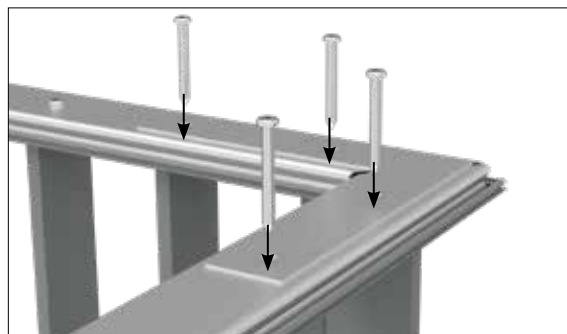
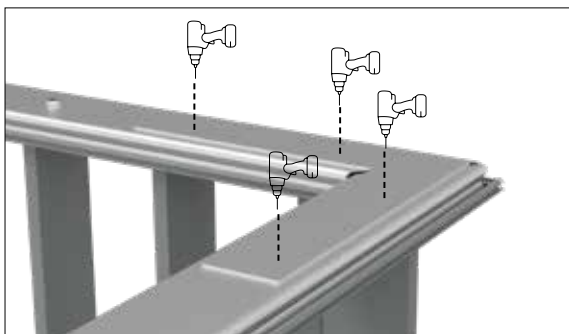
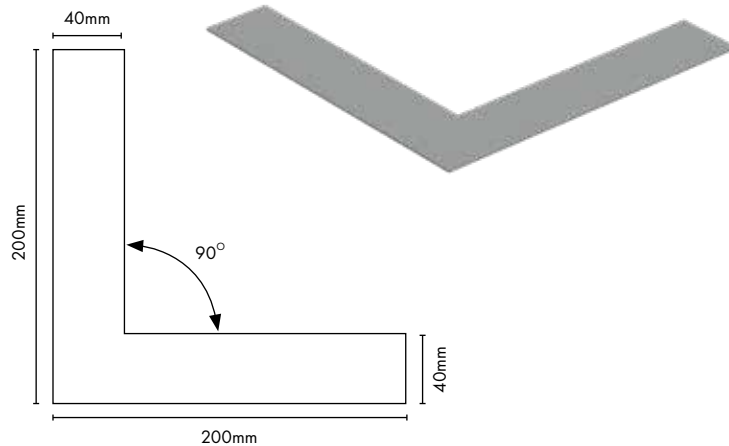



# VISOR™

## 12g Panhead screw

12g x 50mm long  
PACK OF 50

Order Code: **VIS-SCR-BAL-50PK**

- Square drive panhead - SS304
- Use for screwing Visor™ baluster from underside of base rail - lubricate screws before screwing
- 2 x screws required per baluster
- Sold as a 50 pack

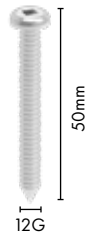

## 14g Panhead screw

14g x 50mm long  
PACK OF 50

Order Code: **VIS-SCR-SIDEBAL-50PK**

- Square drive panhead - SS304
- Use for:
  - A) screwing Visor™ balusters sideways through base rail and;
  - B) screwing top friction plate to baluster
- Lubricate screws before screwing
- Sold as a 50 pack



## Countersunk phillips head screw

8g x 25mm long  
PACK OF 50

**Black, White or Mill finish**

Order Code: **VIS-SCR-CSK-50PK-B (Black)**

**VIS-SCR-CSK-50PK-W (White)**

**VIS-SCR-CSK-50PK (Mill)**

- Phillips head countersunk screw - SS304
- Use for screwing:
  - (A) end plate to undercapping plate;
  - (B) wall bracket to undercapping plate;
  - (C) offset bracket to handrail
- Sold as a 50 pack

FINISHES

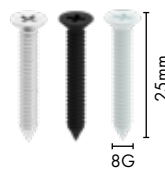

## Driver bit

Order Code: **DB-PH3**

- Driver bit to suit Phillips #3 screw head



## Square head driver bit

Order Code: **DB-SQ3.4**

- Driver bit to suit 3.4mm square screw head hole



## Soudafix CA1400 Chemical anchor

280mL

Order Code: **SOUD-CA1400**

- High performance, two-component chemical anchoring resin for the pressure-free securing of anchoring rods, studs, threaded collars etc
- Easy to use and apply
- Fast cure (20°C=45min full cure; 30°C=25min full cure)
- Vinyl ester styrene free
- Can be used in damp concrete
- Apply with standard caulking gun

## Soudal heavy duty cartridge gun

Order Code: **SOUD-GUN**

- Heavy duty, steel trade quality cartridge gun
- Geared ratio 18:1 for smooth operation and easy application
- Dripless system feature automatically releases pressure to reduce mess/waste
- Suits 300ml silicone cartridges and 280ml chemical anchor



## Horseshoe Packers

20 PACK

**Black finish**

Order Code: **HSP-75X38-1MM-20PK**

1mm thick

**HSP-75X38-3MM-20PK**

3mm thick

- 38mm wide x 75mm long horseshoe packers
- 10.5mm slot
- Available in 1mm or 3mm thick (20 per pack)
- Durable black solid polypropylene
- Handy for levelling adjustments while installing
- Easy to cut down to required length

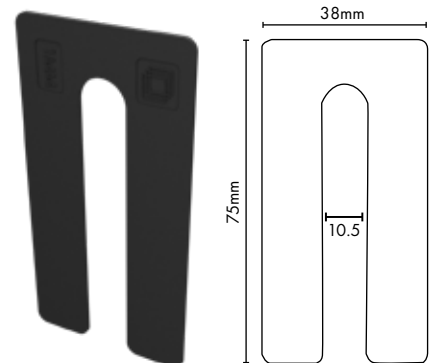

Available 1mm or 3mm thick



# VISOR™

## M12 dome nut

PACK OF 4 – SS316

**Black or Mill finish**

Order Code: **GS-DN-4PK-B (Black)**

**GS-DN-4PK (Silver)**

- 4x dome nuts & 4x split washers
- Stainless steel 316
- Suits M12 thread

*Silver recommended for white powder coat installations.  
Black recommended for black powder coat installations.*



FINISHES



BLACK

MILL

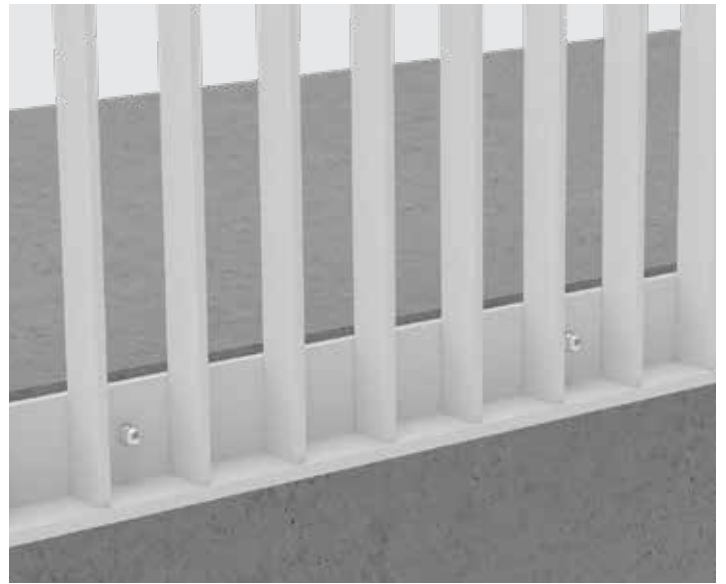

## M 12 FIXINGS

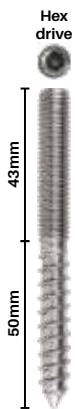

### 93mm lag screw

SS304

**M12 thread**

Order Code: **GS093LAG**

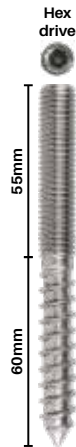

### 115mm lag screw

SS304

**M12 thread**

Order Code: **GS115LAG**

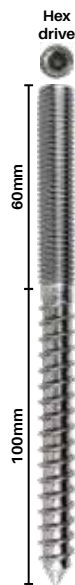

### 160mm lag screw

SS304

**M12 thread**

Order Code: **GS160LAG**

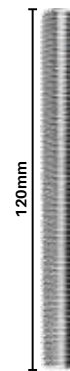

### 120mm threaded rod

SS304

**M12 thread**

Order Code: **GS120ROD**

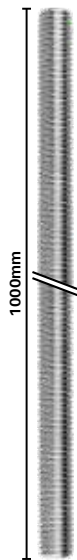

### 1000mm threaded rod

SS304

**M12 thread**

Order Code: **GS1000ROD**



---

Visor™ can be used in various architectural settings, both residential and commercial. It can be integrated into indoor or outdoor spaces, such as staircases, balconies, terraces, or mezzanines. The versatility of Visor™ allows it to blend seamlessly with different architectural styles, whether it's a contemporary building or a renovation project.





# ESTIMATING TOOL

Contact us for our FREE Excel estimating tool. Simply insert overall span lengths for an instant bill of materials.

**Benefits of using the estimating tool are:**

- ✔ **1. ACCURACY**  
 Estimating calculators assist in reducing chance of human error.
- ✔ **2. TIME-SAVING**  
 Manual calculations can be time-consuming. The estimating tool allows for more efficient use of time.
- ✔ **3. CONSISTENCY**  
 Using the same estimating tool over multiple projects ensures that the methodology remains consistent. This ensures that comparisons between projects or different sections of a plan are valid.
- ✔ **4. EASE OF USE**  
 The Excel interface is user-friendly and allows simple input of balustrade spans.
- ✔ **5. FAST QUOTING**  
 With a bill of materials known, obtain instant pricing.



# COMPLIANCE

Extensive physical testing and theoretical analysis has resulted in the VISOR™ system achieving outstanding performance criteria.

Contact us for engineer compliance certification taking into account:

**AS/NZS 1170.0:2002**  
Structural design actions. General Principles.

**AS/NZS 1170.1:2002**  
Structural design actions. Permanent, imposed and other actions.

**AS/NZS 1170.2:2021**  
Structural design actions. Wind actions.

**AS/NZS 1664.1:1997**  
Aluminium structures. Part 1: Limit state design.

**NCC2022**  
Volumes 2 and 3.

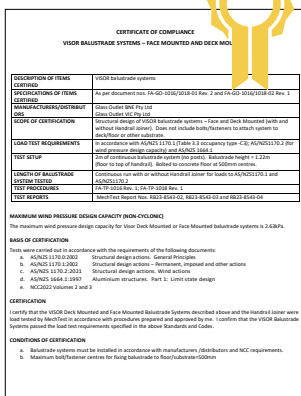





NOTE – Select finish code:  
(EG VIS-4000-DECK-B for black)

# ORDER CODES

Order Code	Description	Colours
VIS-1200-BAL-B/W/M-4PK	Aluminium 50x10mm baluster – 1200mm high (4 pack)	  
VIS-6100-BAL-B/W/M	Aluminium 50x10mm baluster – 6100mm long	  
VIS-4000-DECK-B/W/M	Aluminium deck mount 'T' profile – 4000mm long	  
VIS-4000-COV-DECK-B/W/M	Aluminium side cover profile – 4000mm long	  
VIS-4000-FACE-B/W/M	Aluminium face mount 'L' profile – 4000mm long	  
VIS-5000-FM-NM-M	Aluminium face mount 'L' profile – non machined – 5000mm long	
VIS-4000-COV-FACE-B/W/M	Aluminium bottom cover slide in profile – 4000mm long	  
VIS-4000-PLATE-B/W/M	Aluminium undercapping plate – 4000mm long	  
VIS-4942-PLATE-R-B/W/M	Aluminium undercapping plate – raked – 4942mm long	  
VIS-3050-INS-2PK	Aluminium friction insert – 3050mm long (2 pack)	 *Clear anodised
VIS-6100-HRAIL-B/W/M	Aluminium rectangular handrail – 70x23mm – 6100mm long	  
VIS-BRACKET-B/W/M-2PK	Aluminium offset bracket (2 pack)	  
VIS-EP-B/W/M	Aluminium 70x23mm handrail end plate	  
VIS-WB-B/W/M	Aluminium 63x20mm wall/post bracket	  
VIS-DMEP-B/W/M-2PK	Aluminium 'T' deck mount end plates (2 pack)	  
VIS-FMEP-B/W/M-2PK	Aluminium 'L' face mount end plates (2 pack)	  
VIS-J-M	Aluminium inline joiner for handrail friction insert	
VIS-J90-M	Aluminium 90 degree joiner for handrail friction insert	
VIS-SCR-BAL-50PK	12g x 50mm panhead screw (50 pack)	
VIS-SCR-SIDEBAL-50PK	14g x 50mm panhead screw (50 pack)	
VIS-SCR-CSK-50PK-B/W	8g x 25mm countersunk phillips head screw (50 pack)	  
DB-PH3	Driver bit phillips #3	
DB-SQ3.4	Square head driver bit	

 MATT BLACK  MATT WHITE  MILL



# VISOR™ FABRICATION

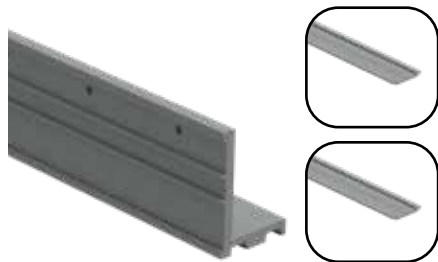
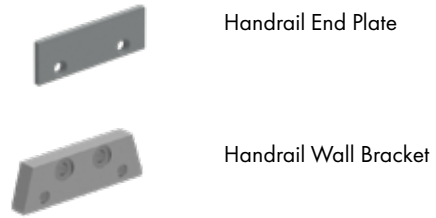
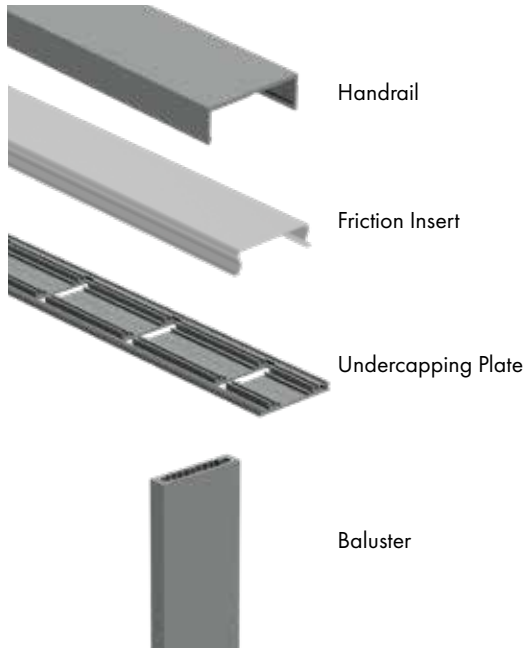

Face Mount Base  
(with 2 x Bottom Covers)

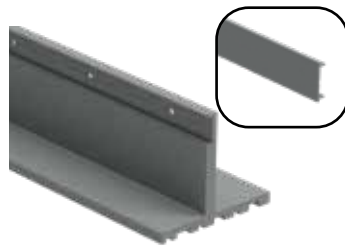

Deck Mount Base  
(with 1 x Side Cover)

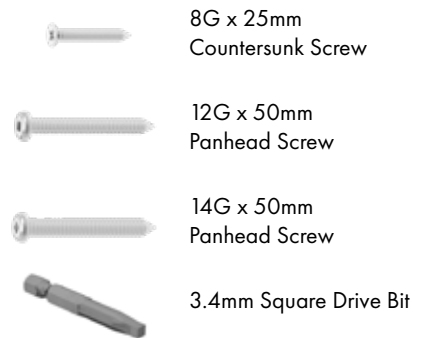

Face Mount End Plates  
(left and right)



Deck Mount End Plates  
(left and right)



Inline Handrail Joiner



90 Degree Handrail Joiner



# VISOR™ FABRICATION

## FACE MOUNT APPLICATION

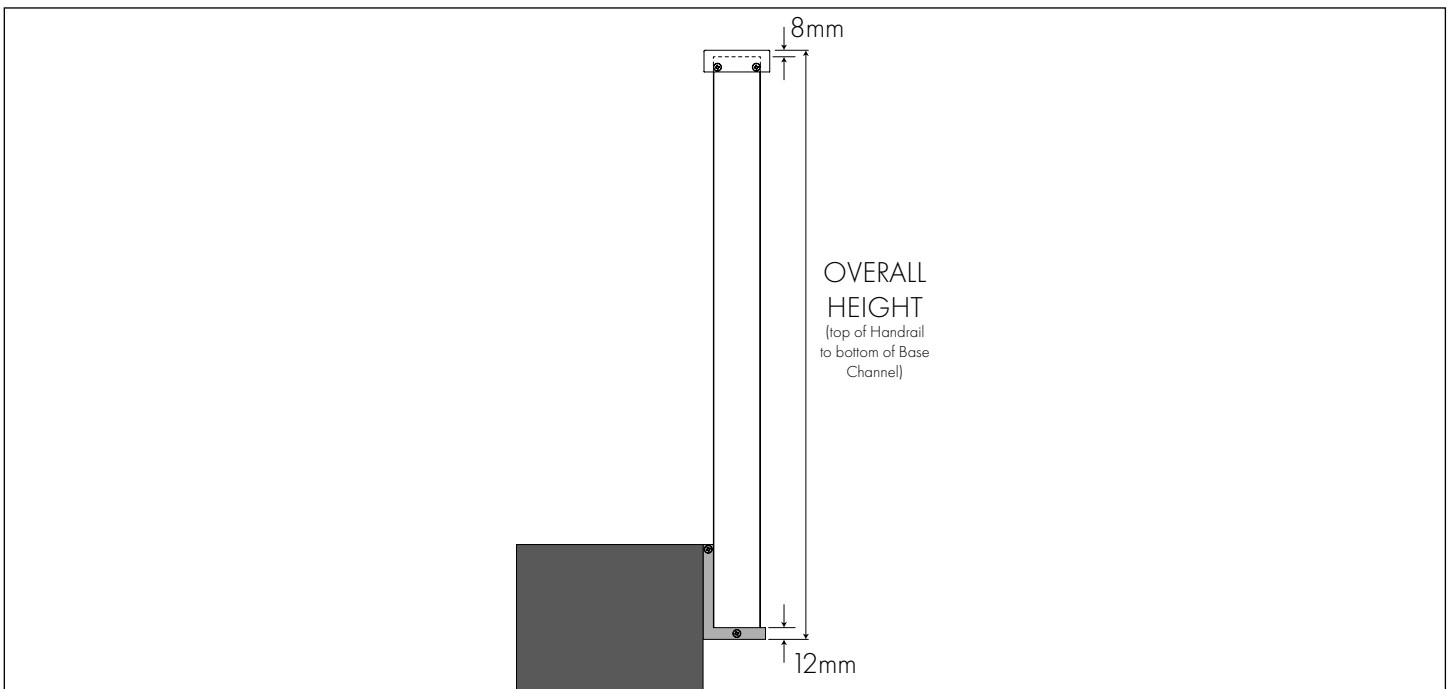
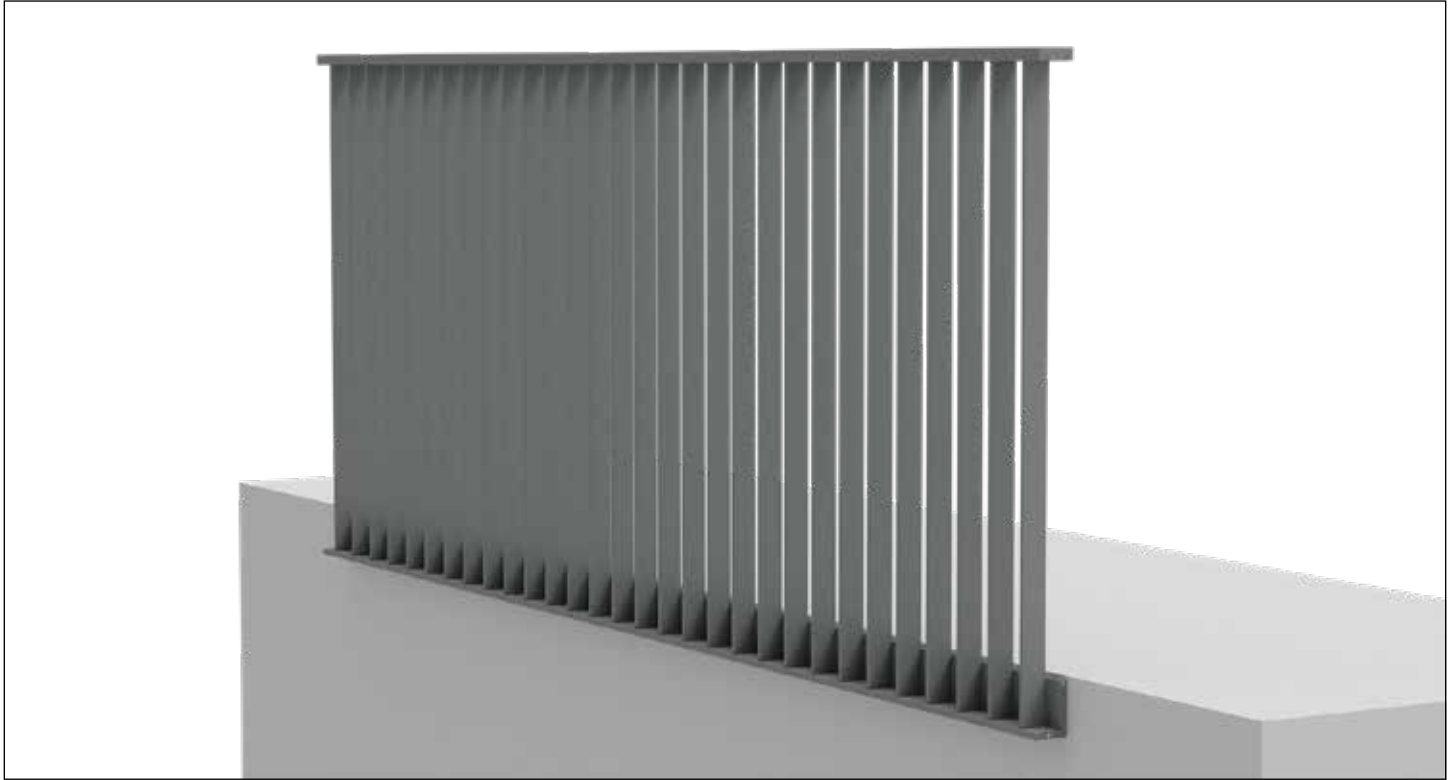

- 1 Cut Balusters to the required length, noting the Baluster height on the Face Mount Base and protrusion into the Handrail.  
Baluster Height = Overall height – 20mm



## VISOR™ FABRICATION

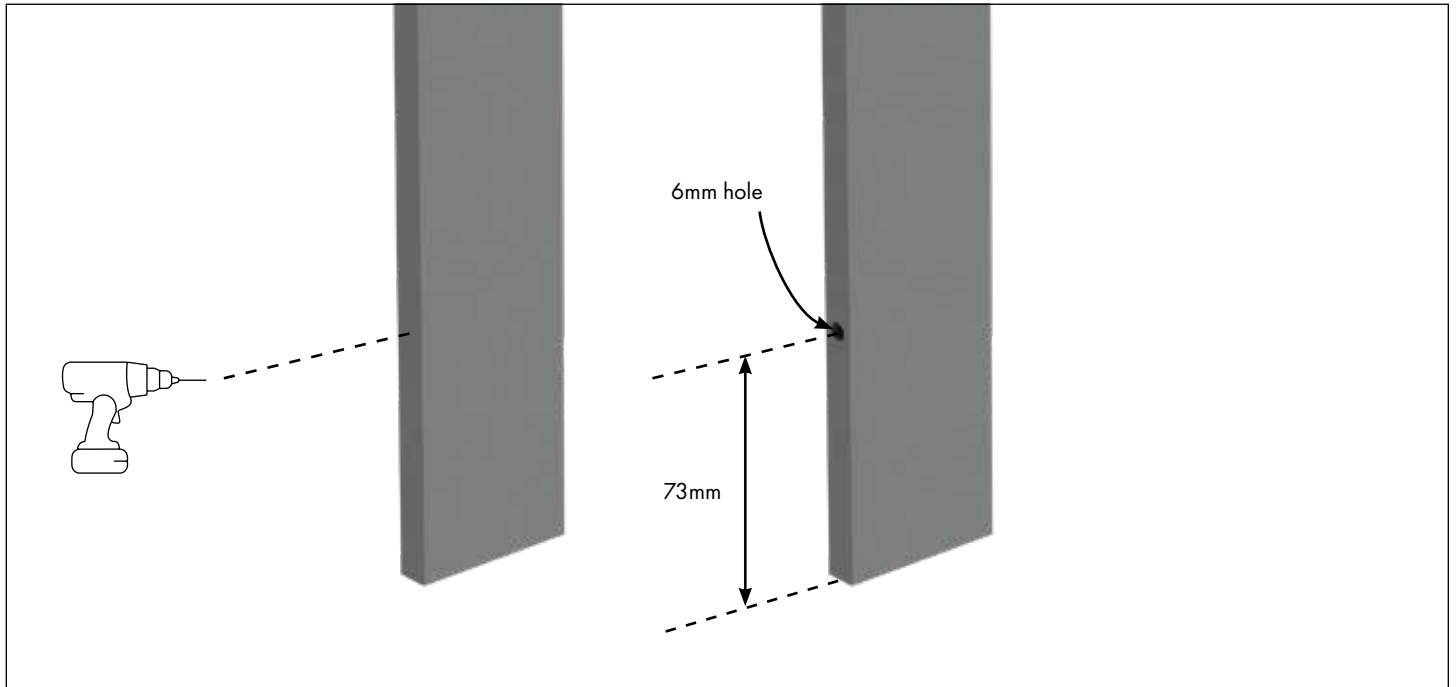

- 2 At one end (only) of the 50mm x 10mm Baluster, drill 1 x 6mm hole centrally on the 10mm face of the Baluster, 73mm from the end.

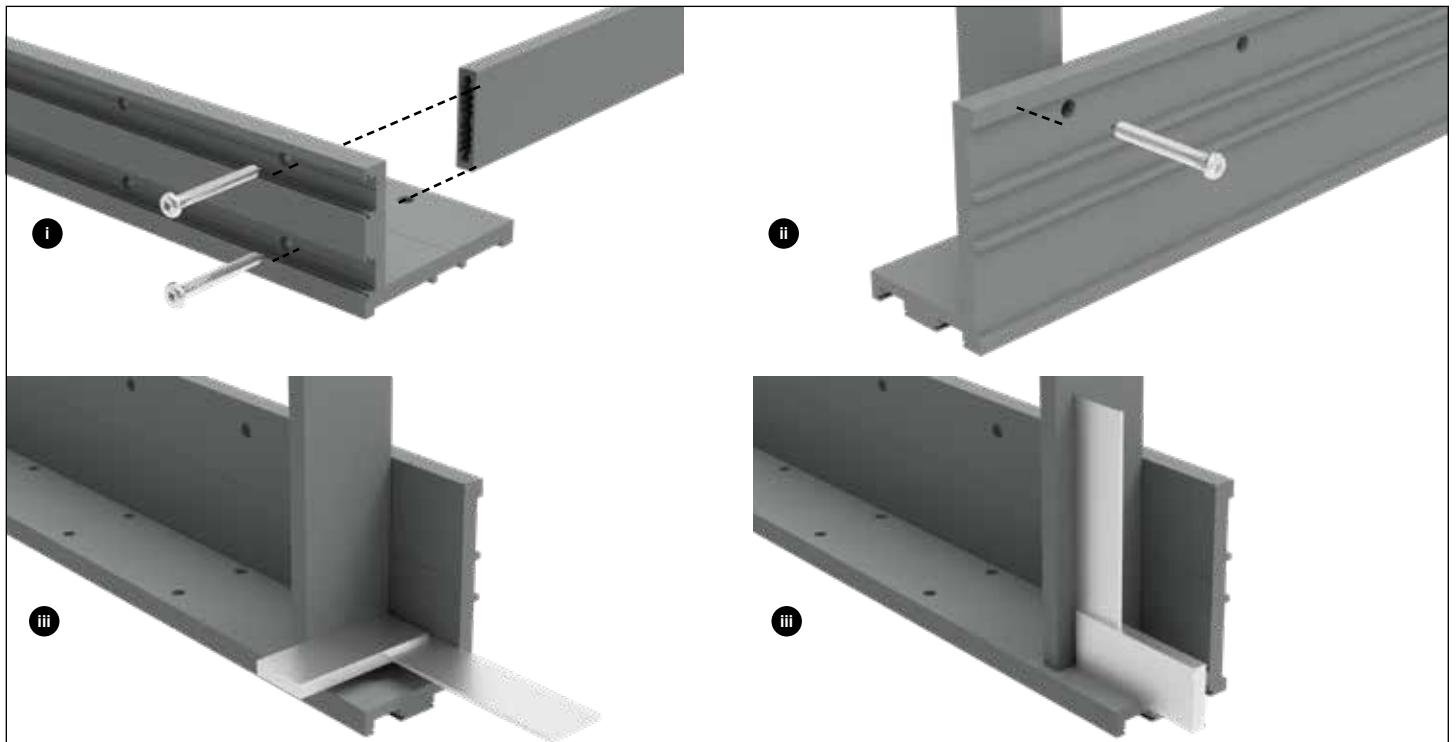

- 3 After cutting the Face Mount Base to the required length (see Appendix 3 for mitred corners), on a flat, padded surface;
- Affix each Baluster using 2x 12G x 50mm panhead screws to the underside of the pre-drilled Face Mount Base.
  - Affix each Baluster with 1x 14G x 50mm panhead screw to the side of the pre-drilled Face Mount Base.
  - Ensure each Baluster is square in the base before a final tighten of screws.

NOTE: A light lubricant is recommended when affixing screws.

# VISOR™ FABRICATION

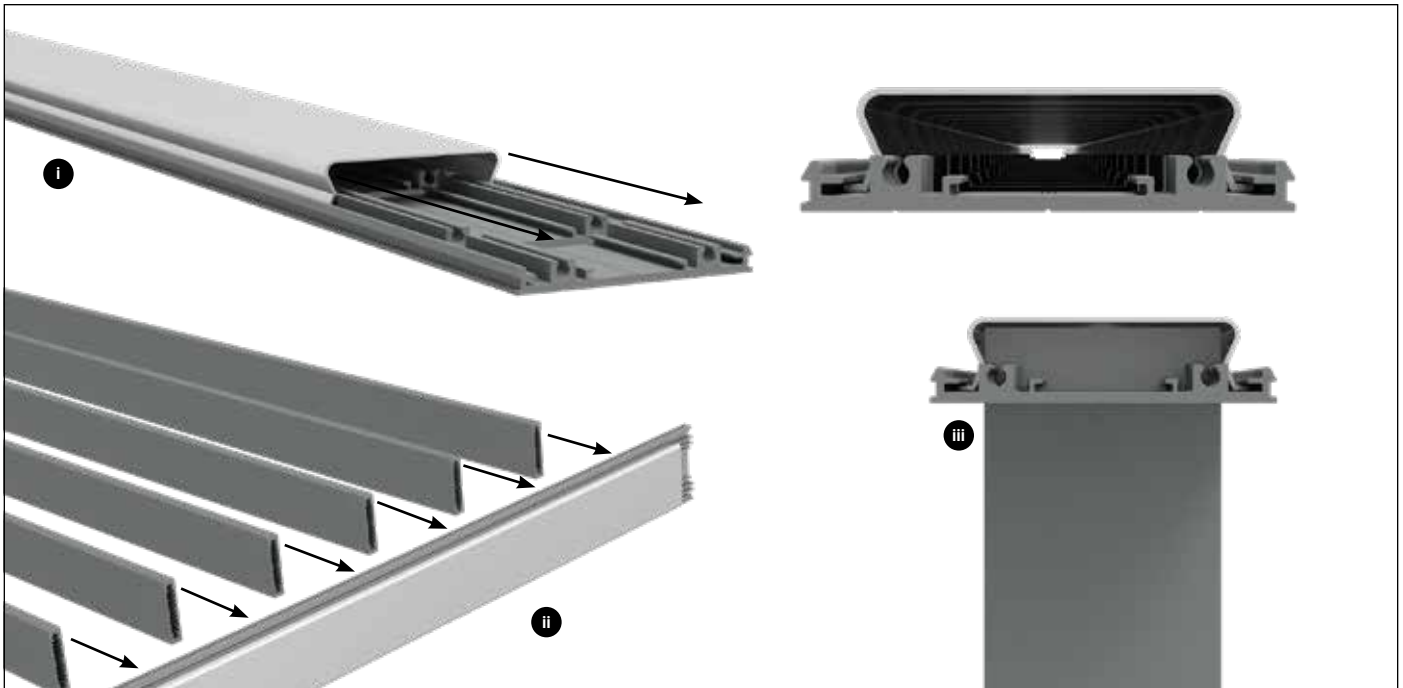

- 4 Once all Balusters are affixed square on the Face Mount Base, cut the Undercapping Plate and Friction Insert to suit the Face Mount Base length and Baluster spacings (see Appendix 1 for Handrail termination considerations);
- Slide the Friction Insert into the Undercapping Plate.
  - While the panel is lying flat, tap the slotted Undercapping Plate into the top of the Balusters.
  - Ensure all Balusters touch the inner face of the Friction Insert.

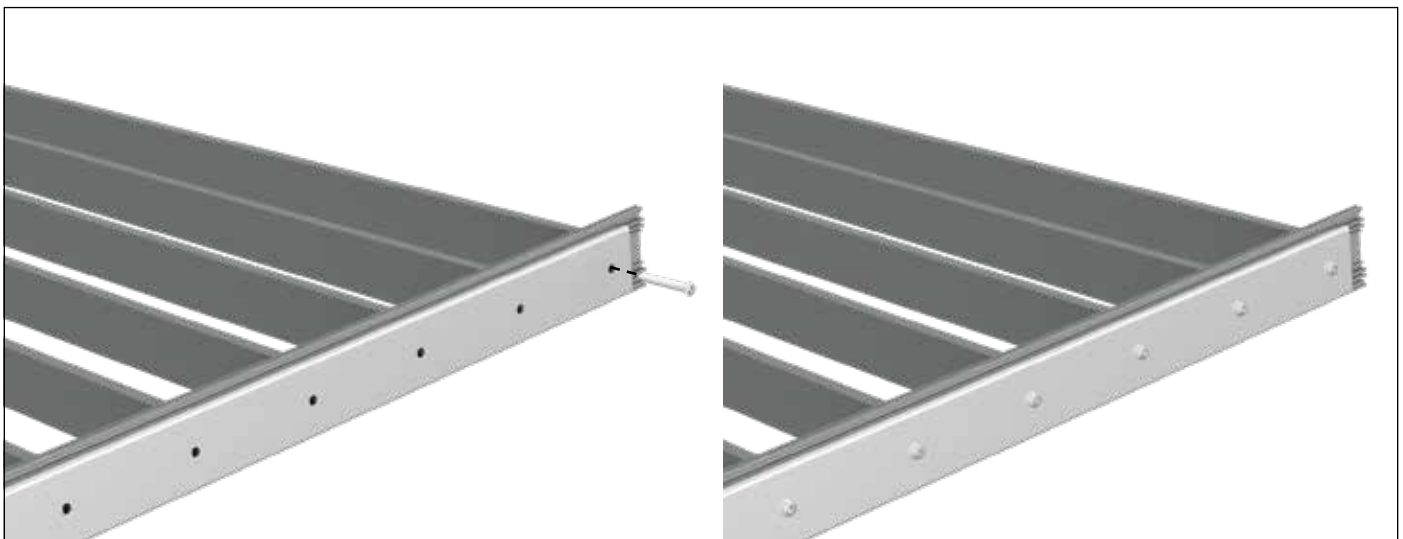

- 5 Drill a 6mm hole to the top v-groove of the Friction Insert, aligning to the centre of each Baluster.  
Affix 1 x 14G x 50mm Panhead Screw to the top of each Baluster.



# VISOR™ FABRICATION



- 6 Cut the two Face Mount Base bottom covers to suit the length of the base and slide both into the bottom recesses to conceal the screw fixings.

NOTE: The ends of the bottom covers may need to be trimmed or filed to ensure smooth insertion into the Face Mount Base recesses.

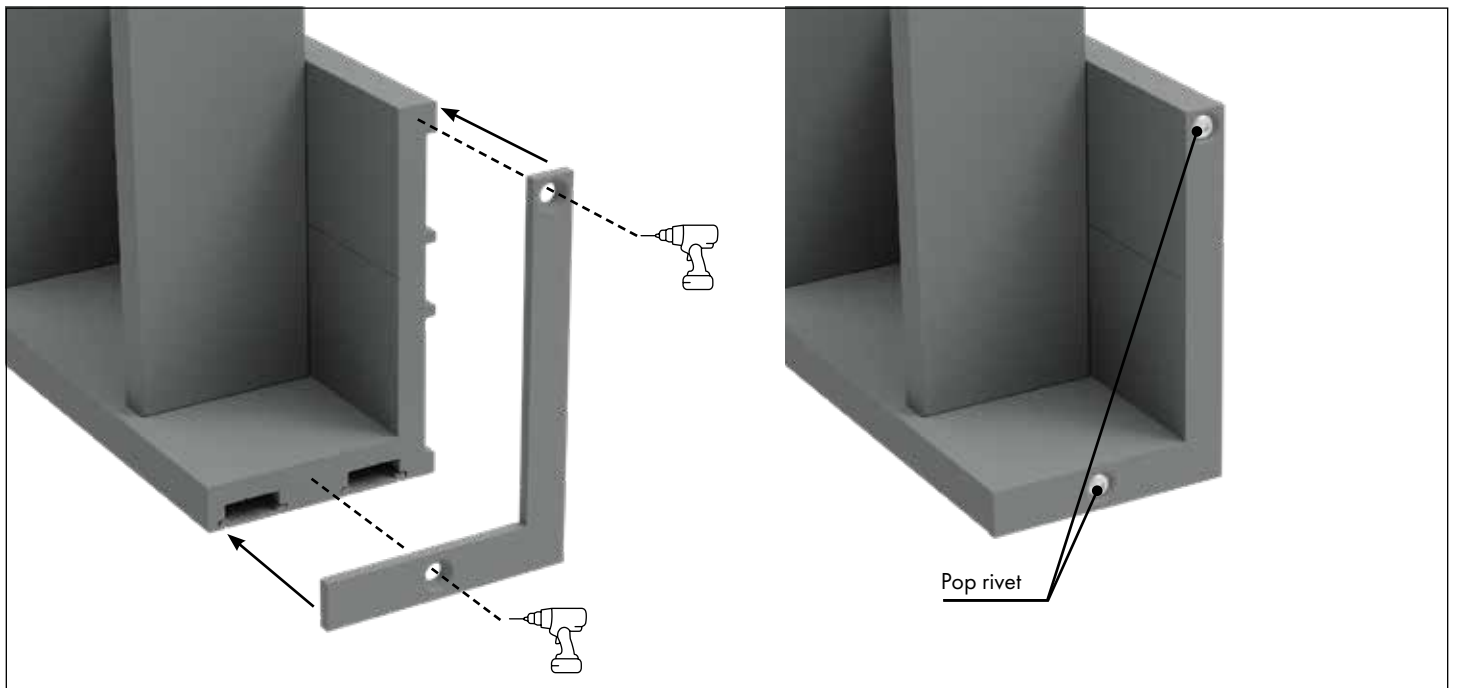

- 7 Attached the Face Mount End Plates to any exposed base profile end by drilling a 3.5mm hole and affixing with a colour matched 3.2mm Dia. aluminium pop rivet (not supplied).



# VISOR™ FABRICATION

## AFTER FABRICATED PANEL INSTALLATION

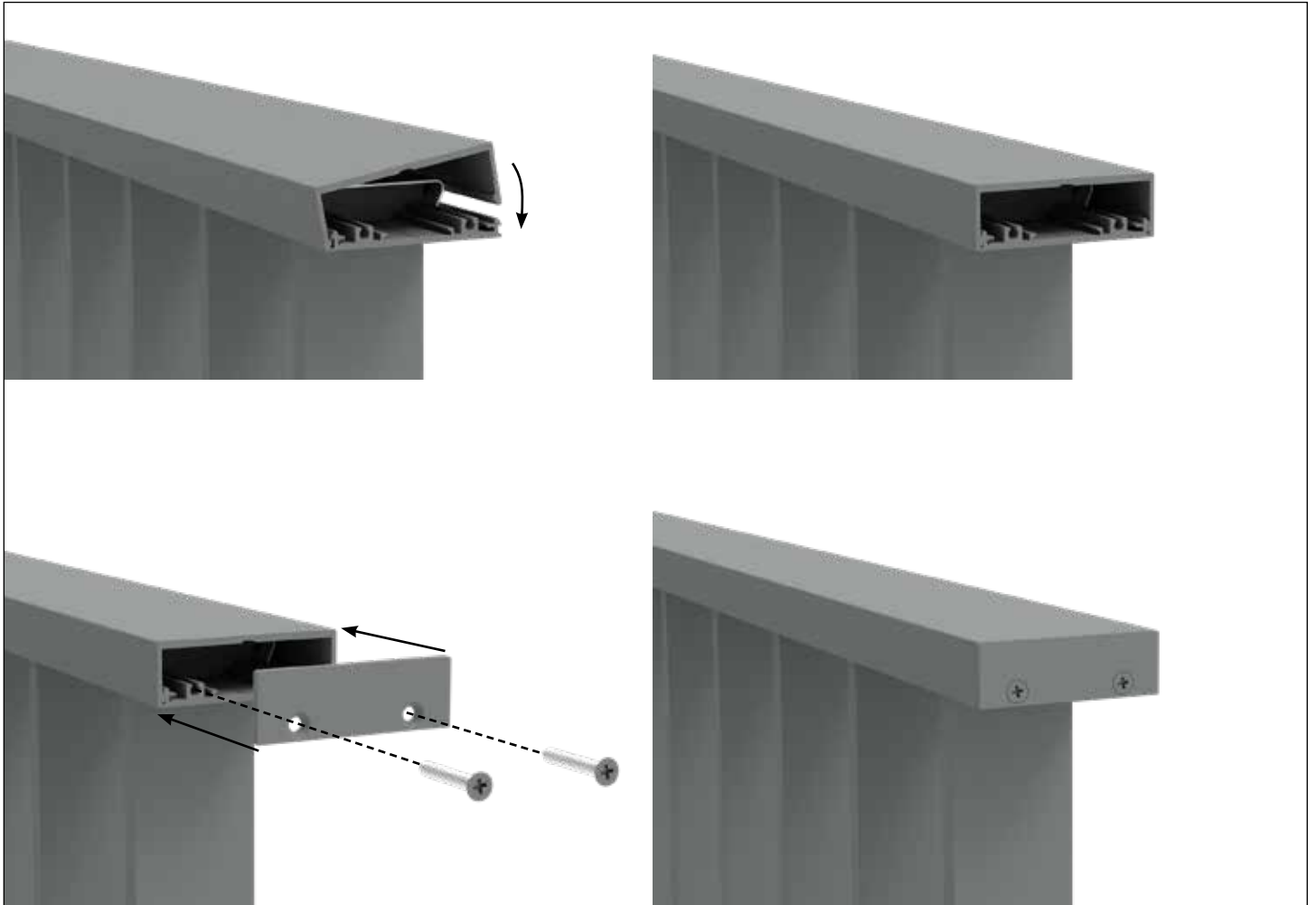

- 8 Affix all Handrails, Handrail Joiners, Handrail End Plates, or Handrail Offset Brackets after the installation of the fabricated panel (see Appendix 1 and 2). Example of End Plate shown above.

NOTE: Ensure the outer Handrail spans any inline joins in the Handrail Undercapping and Friction Insert.



# VISOR™ FABRICATION

DECK MOUNT APPLICATION

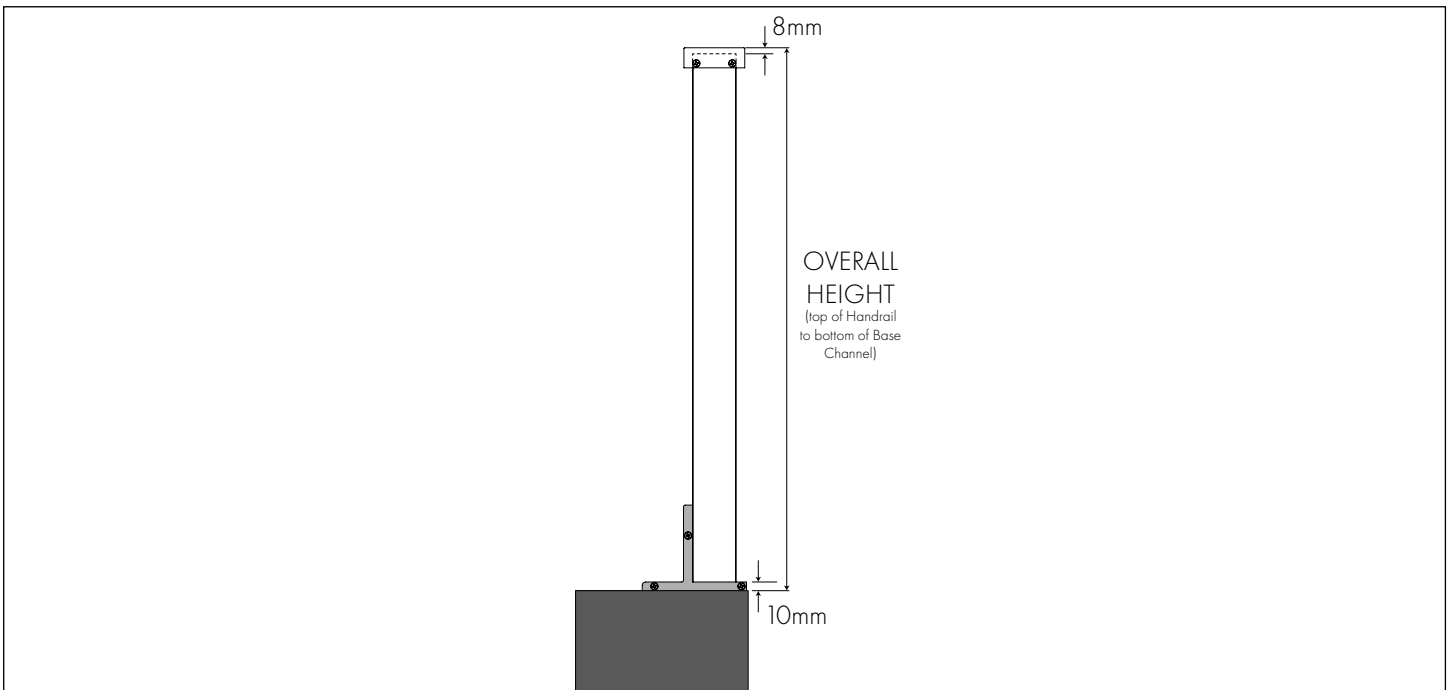
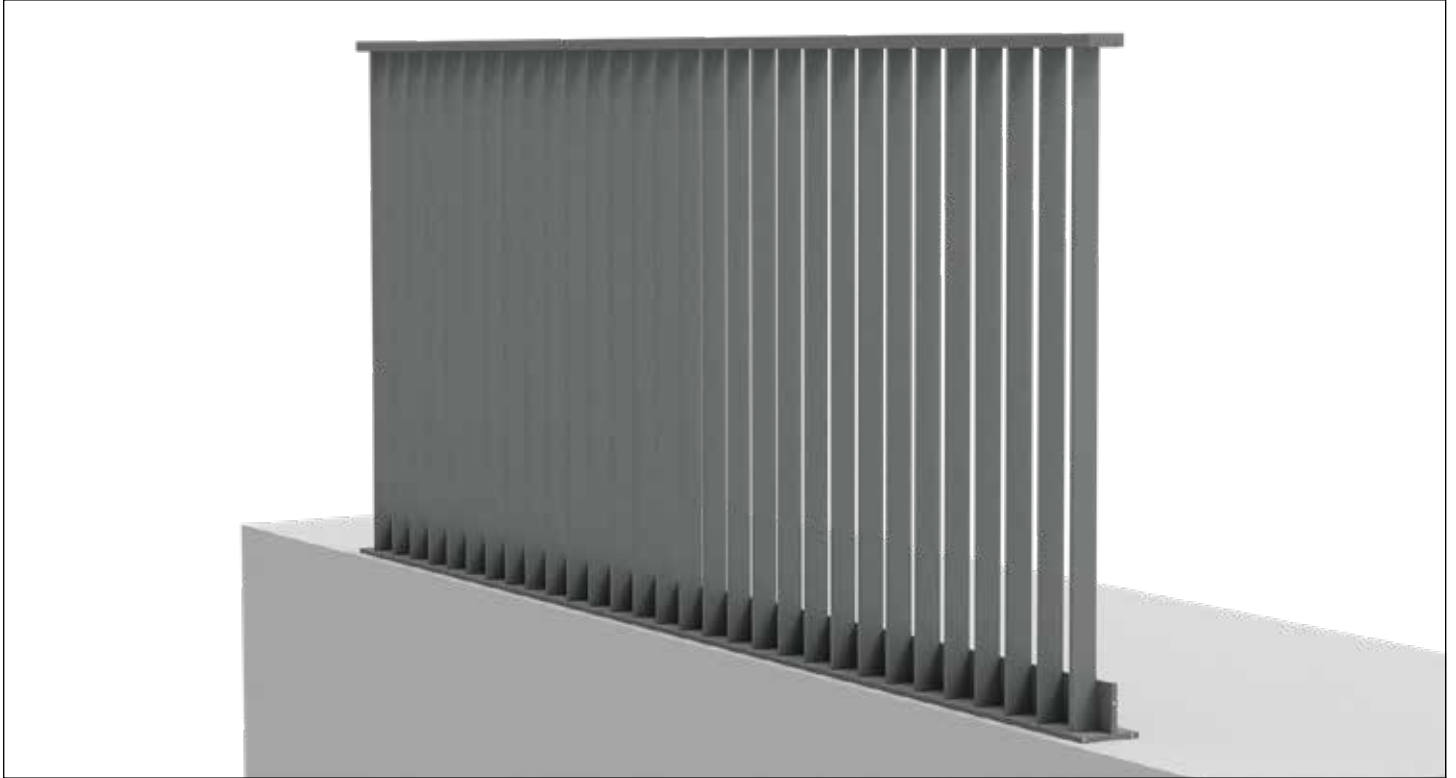

- A** Cut Balusters to the required length, noting the Baluster height on the Deck Mount Base and protrusion into the Handrail.  
Baluster Height = Overall height - 18mm



# VISOR™ FABRICATION

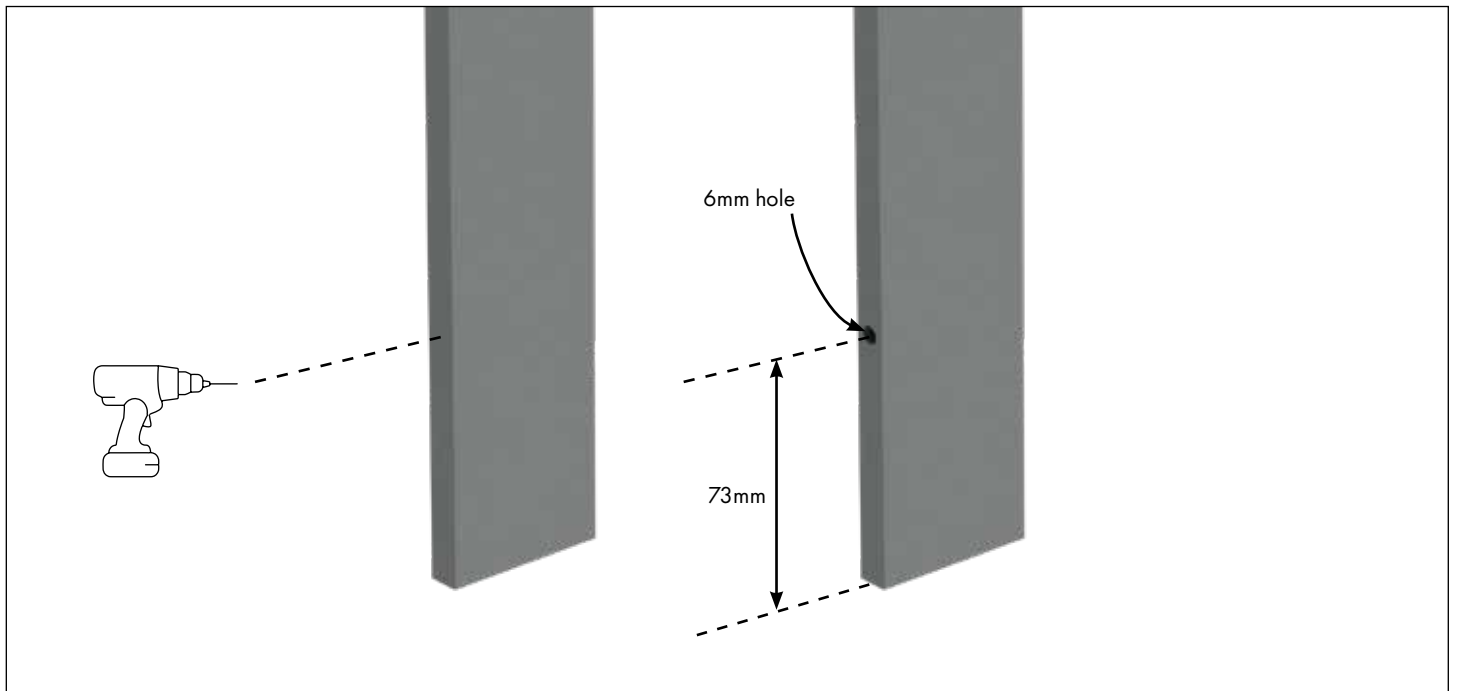

- B** At one end (only) of the 50mm x 10mm Baluster, drill 1 x 6mm hole centrally on the 10mm face of the Baluster, 73mm from the end.

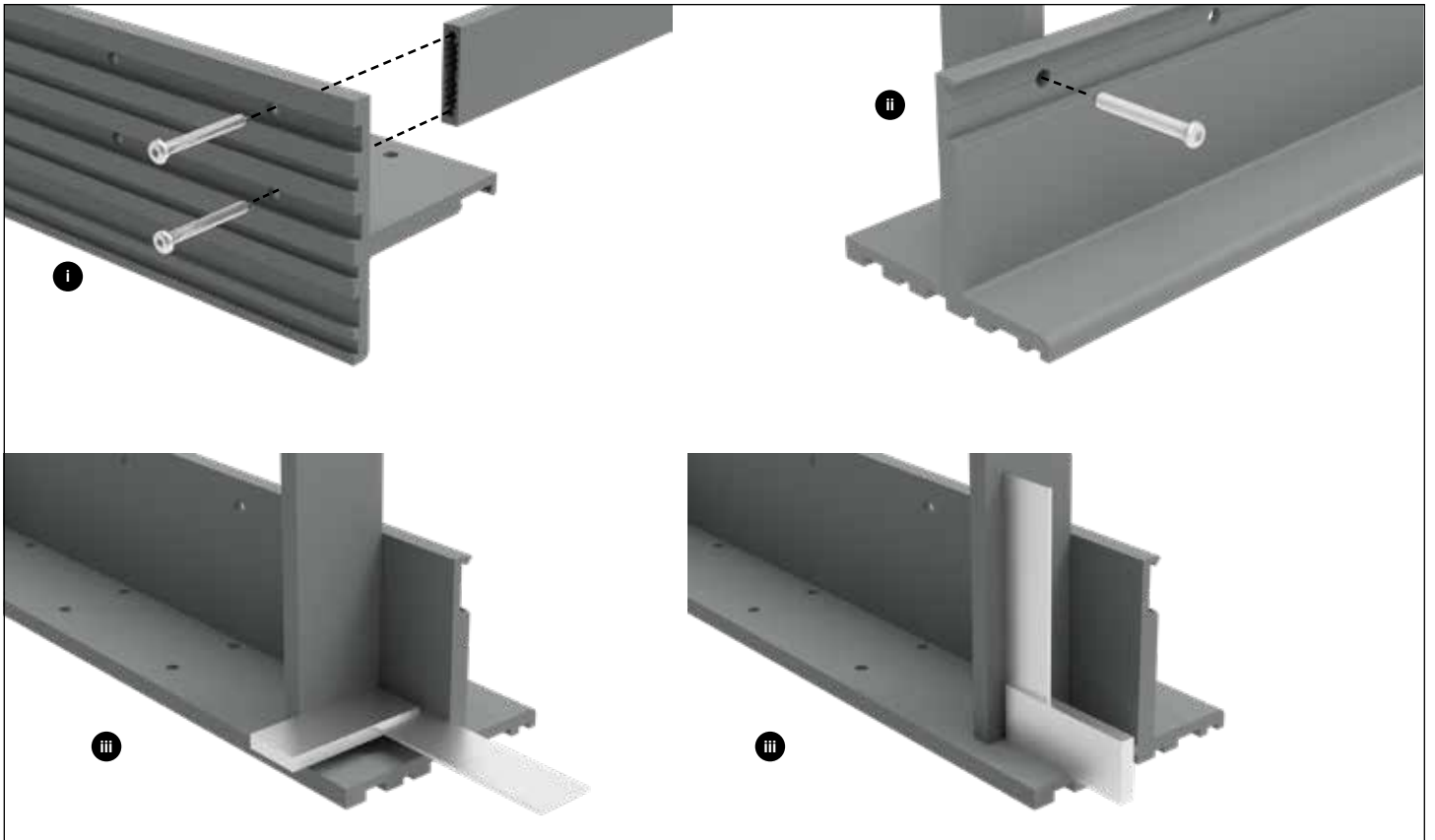

- C** After cutting the Deck Mount Base to the required length (see Appendix 4 for mitred corners, and Appendix 5 for drainage considerations), on a flat, padded surface;
- Affix each Baluster using 2x 12G x 50mm panhead screws to the underside of the pre-drilled Deck Mount Base.
  - Affix each Baluster with 1x 14G x 50mm panhead screw to the side of the pre-drilled Deck Mount Base.
  - Ensure each Baluster is square in the base before a final tighten of screws.

NOTE: A light lubricant is recommended when affixing screws.



## VISOR™ FABRICATION

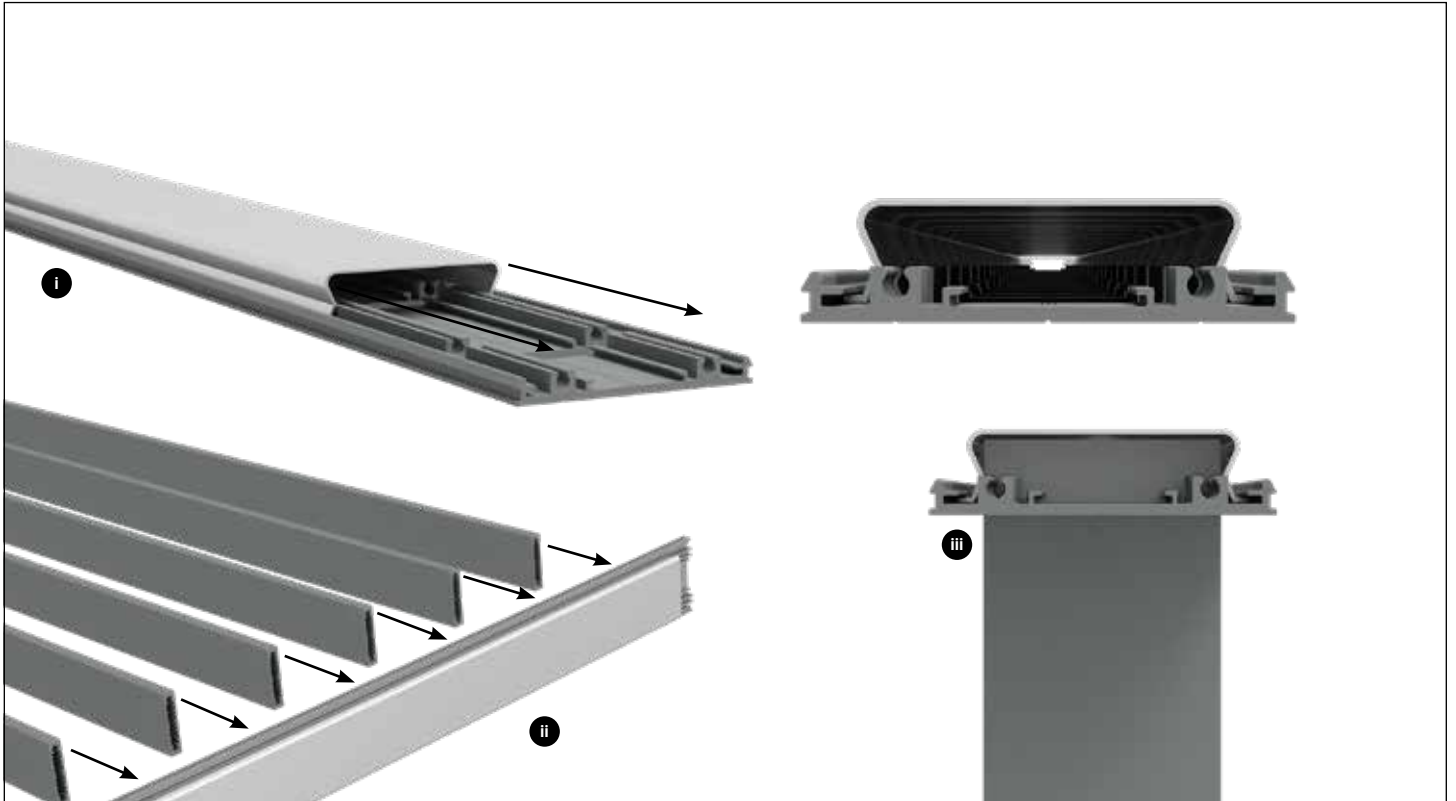

- D** Once all Balusters are affixed square on the Deck Mount Base, cut the Undercapping Plate and Friction Insert to suit the Deck Mount Base length and Baluster spacings (see Appendix 1 for Handrail termination considerations);
- i. Slide the Friction Insert into the Undercapping Plate.
  - ii. While the panel is lying flat, tap the slotted Undercapping Plate into the top of the Balusters.
  - iii. Ensure all Balusters touch the inner face of the Friction Insert.

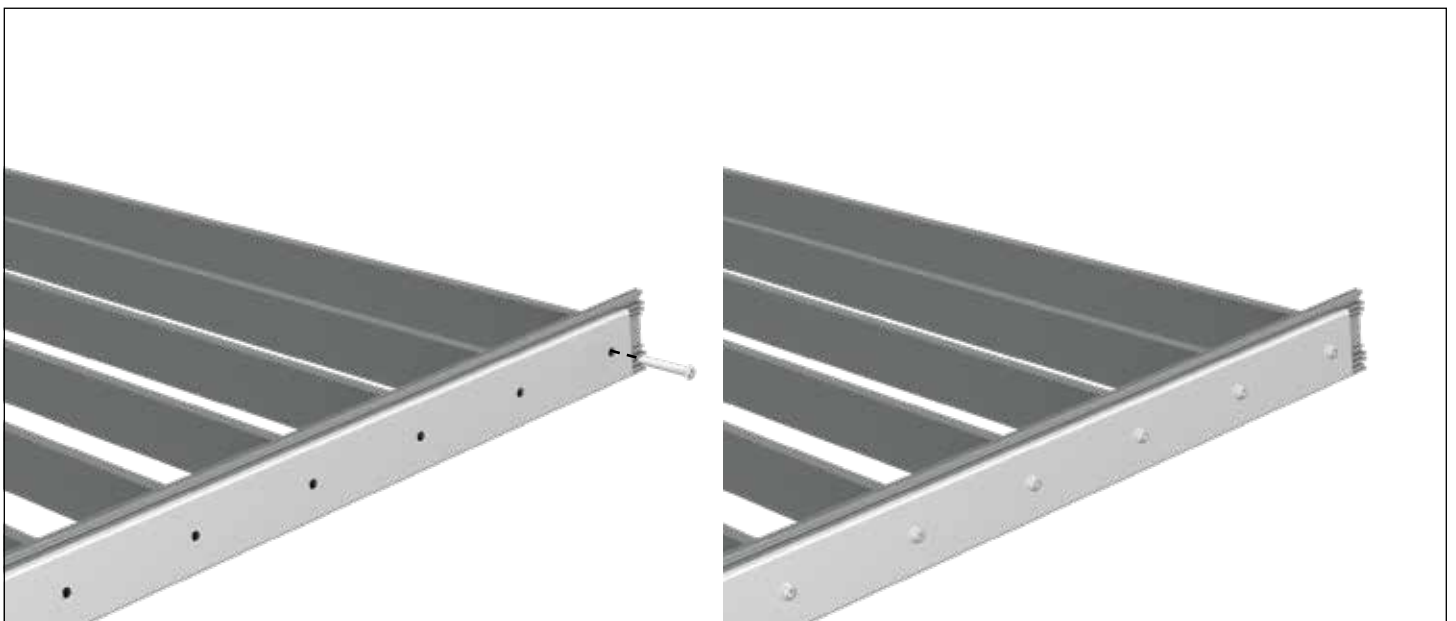

- E** Drill a 6mm hole to the top v-groove of the Friction Insert, aligning to the centre of each Baluster.  
Affix 1x 14G x 50mm Panhead Screw to the top of each Baluster.



## VISOR™ FABRICATION

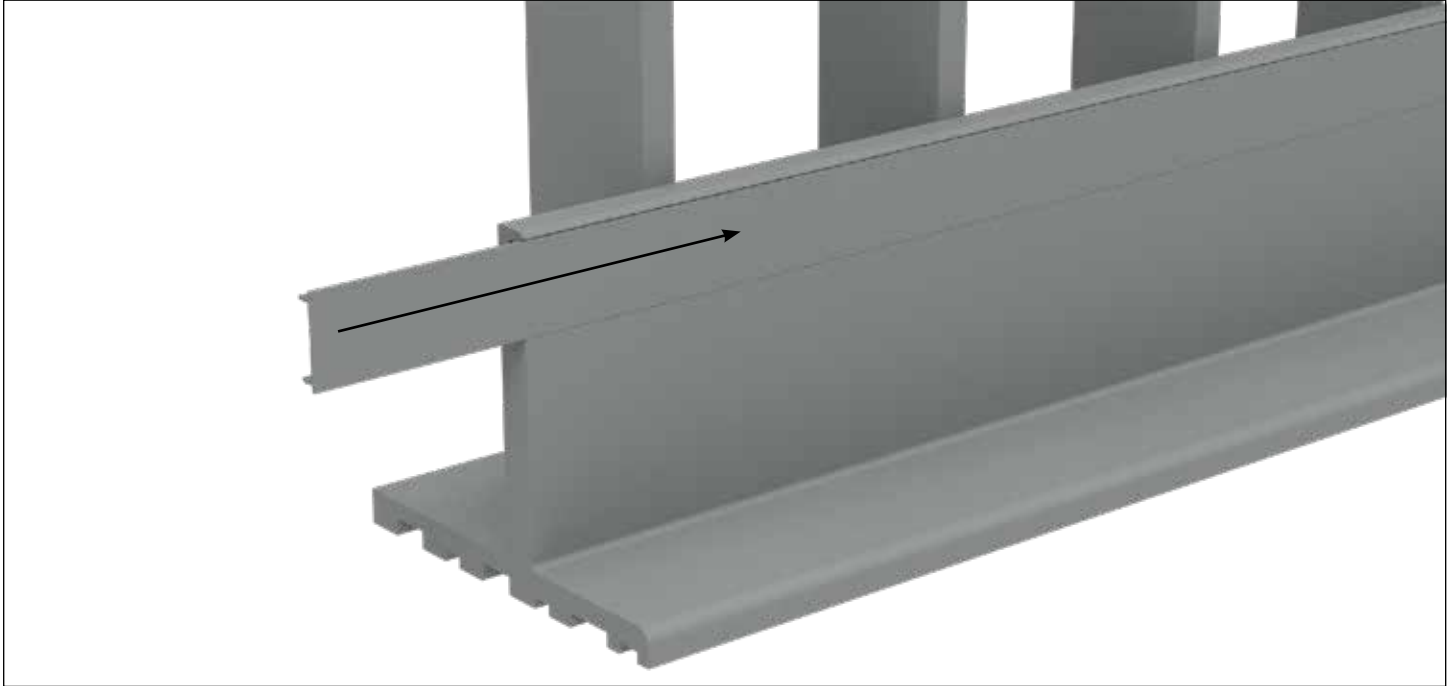

- F** Cut the Deck Mount Base side cover to suit the length of the base and slide into the side recess to conceal the screw fixings.

NOTE: The end of the side covers may need to be trimmed or filed to ensure smooth insertion into the Deck Mount Base recess.

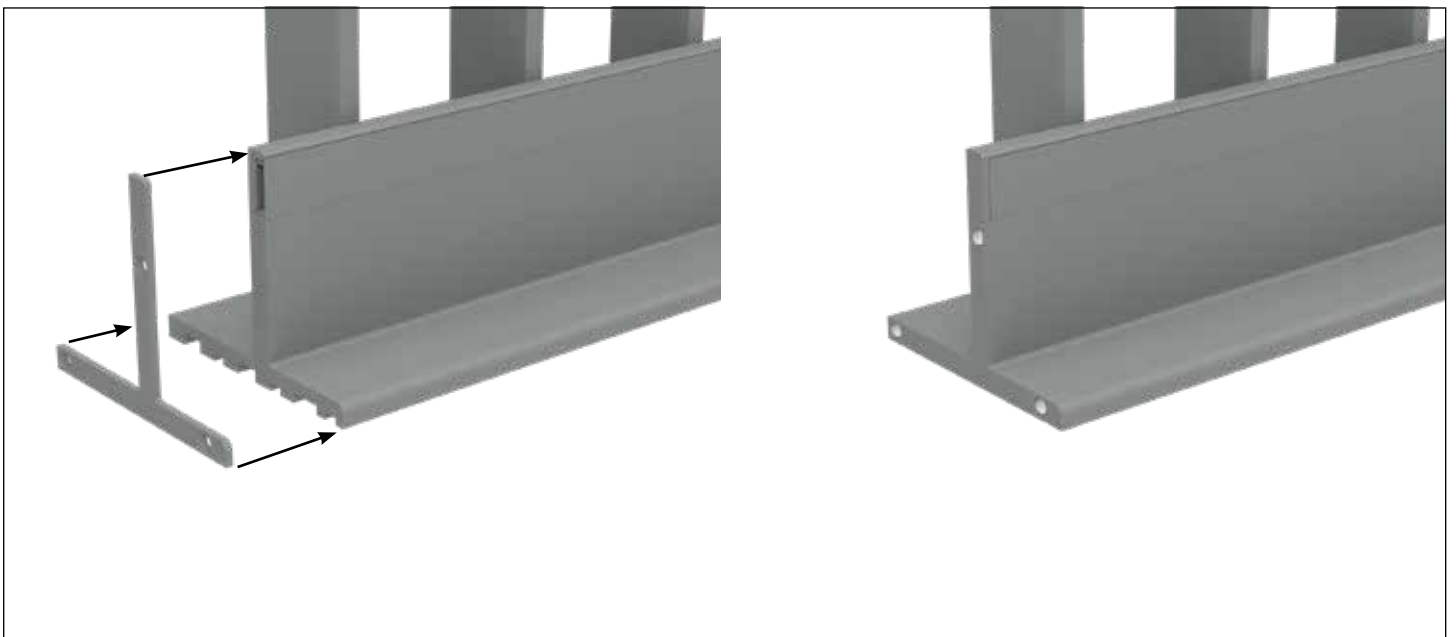

- G** Attach the Deck Mount End Plates to any exposed base profile end by drilling a 3.5mm hole and affixing with a colour matched 3.2mm Dia. aluminium pop rivet (not supplied).



# VISOR™ FABRICATION

## AFTER FABRICATED PANEL INSTALLATION

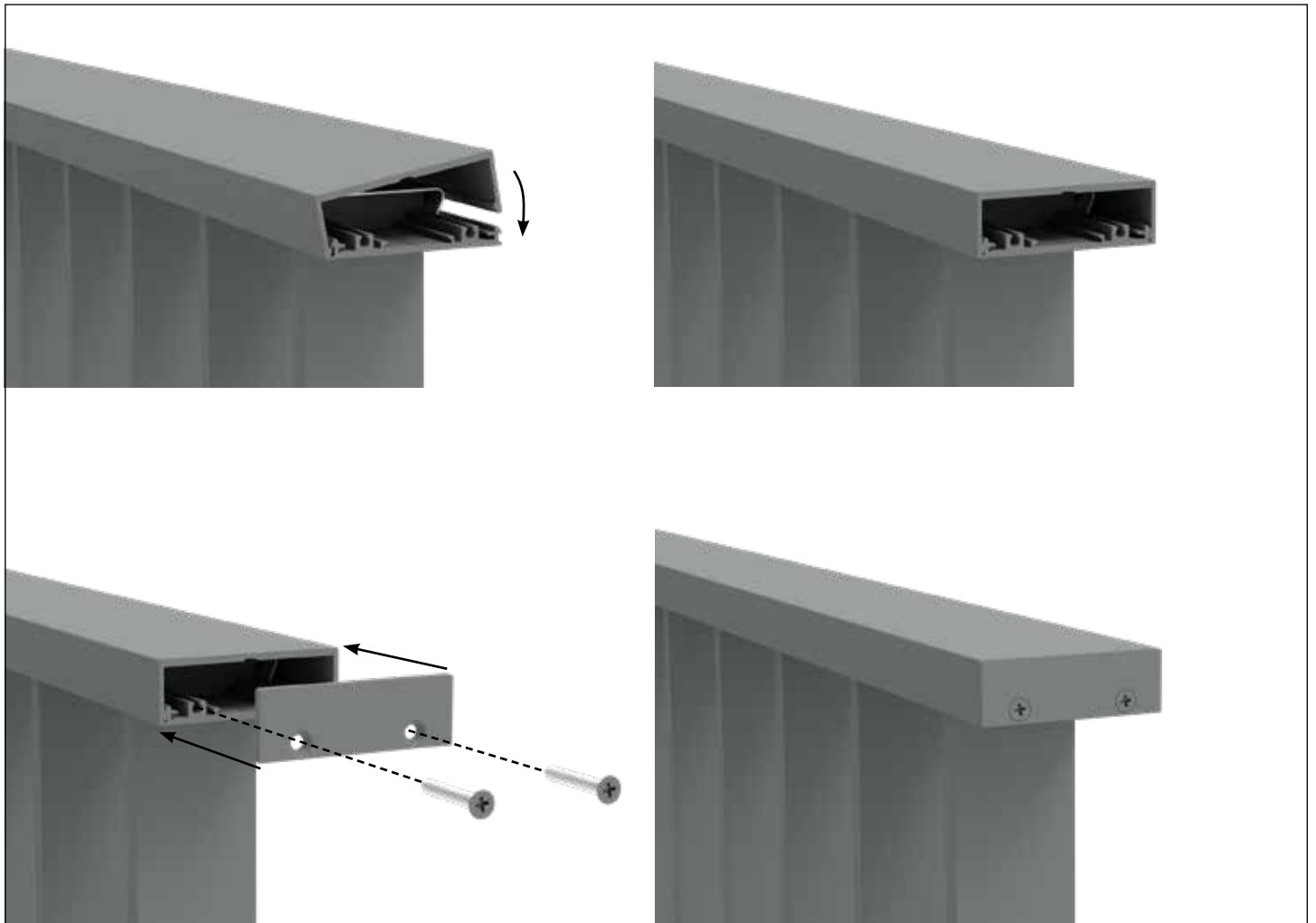

- H** Affix all Handrails, Handrail Joiners, Handrail End Plates, or Handrail Offset Brackets after the installation of the fabricated panel. Example of End Plate shown above.

NOTE: Ensure the outer Handrail spans any inline joins in the Handrail Undercapping and Friction Insert.

# VISOR™ FABRICATION – APPENDIX 1

## HANDRAIL TERMINATION

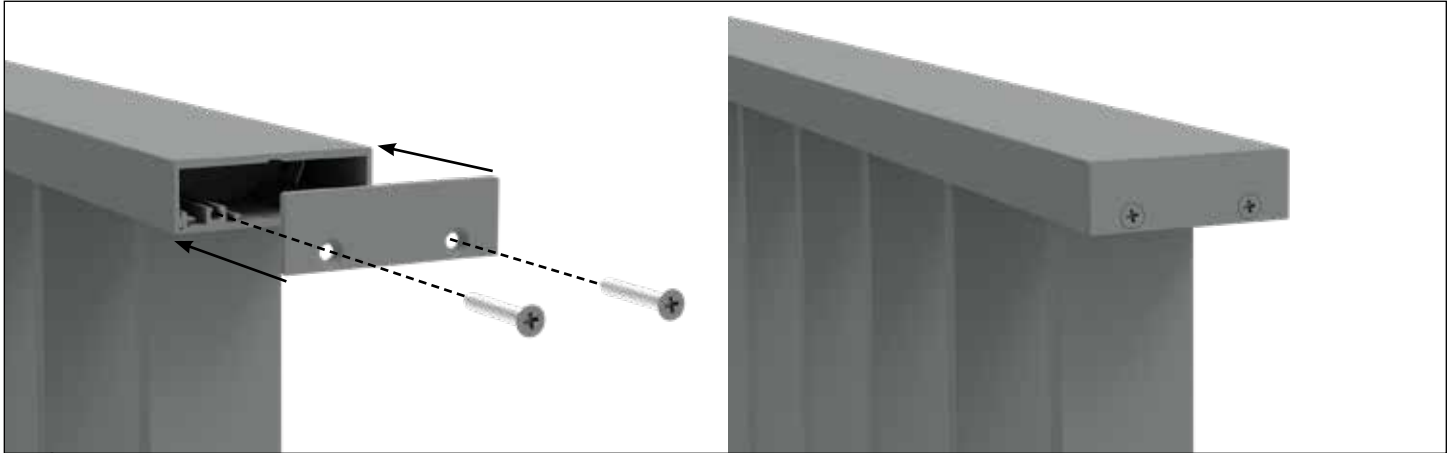

**Option 1: Handrail End Plate**

For Handrails that do not terminate at an existing post or wall, simply screw a Handrail End Cap to the screw flutes in the Undercapping Plate using two 8G x 25mm Countersunk Screws.

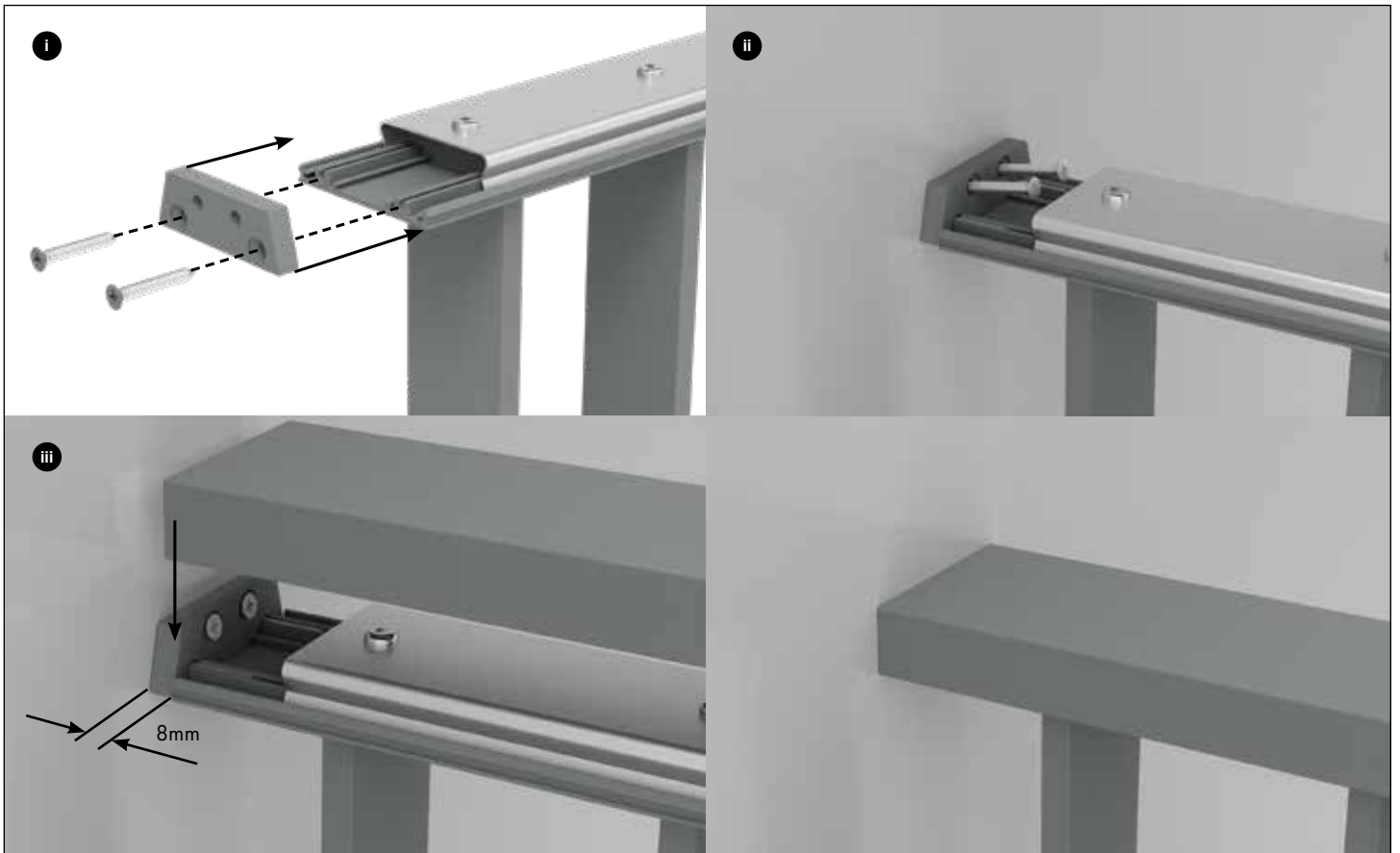

**Option 2: Handrail Wall Bracket**

For Handrails that terminate directly to an existing post or wall, ensure the Undercapping and Friction Insert is cut 8mm shorter and affix the Handrail Wall Bracket to the screw flutes in the Undercapping Plate using two 8G x 25mm Countersunk Screws.

Affix the bracket to the existing wall or post using an appropriate fixture for the substrate (noting the Friction Insert will need to be notched/ trimmed for screw access).

Snap-fix the Handrail over the Handrail Wall Bracket at full length to conceal the fixings.



# VISOR™ FABRICATION – APPENDIX 1

## HANDRAIL TERMINATION

---

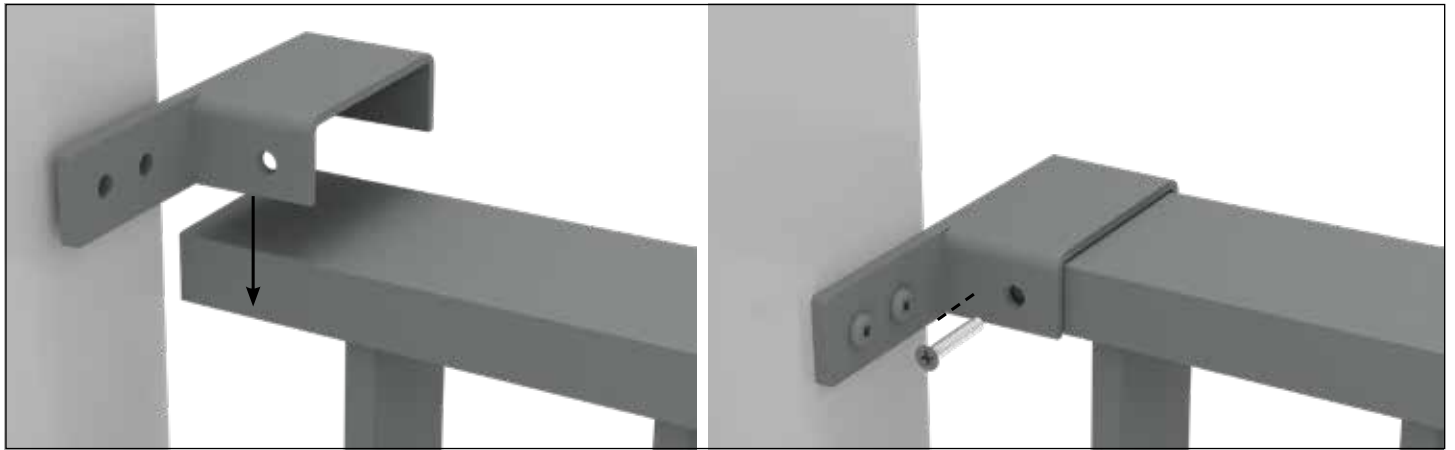

● Option 3: Handrail Offset Brackets

For Handrails that terminate offset to an existing post or wall (particularly when using a Face Mount Base), cut the Handrail, Friction Insert and Undercapping Plate 6mm shorter at each location that a Handrail Offset Bracket is to be used. Affix to the existing post or wall using an appropriate fixture for the substrate. Using an 8G x 25mm countersunk screw, attach the Handrail Offset Bracket to the Handrail and Friction insert.

# VISOR™ FABRICATION – APPENDIX 2

## HANDRAIL JOINERS

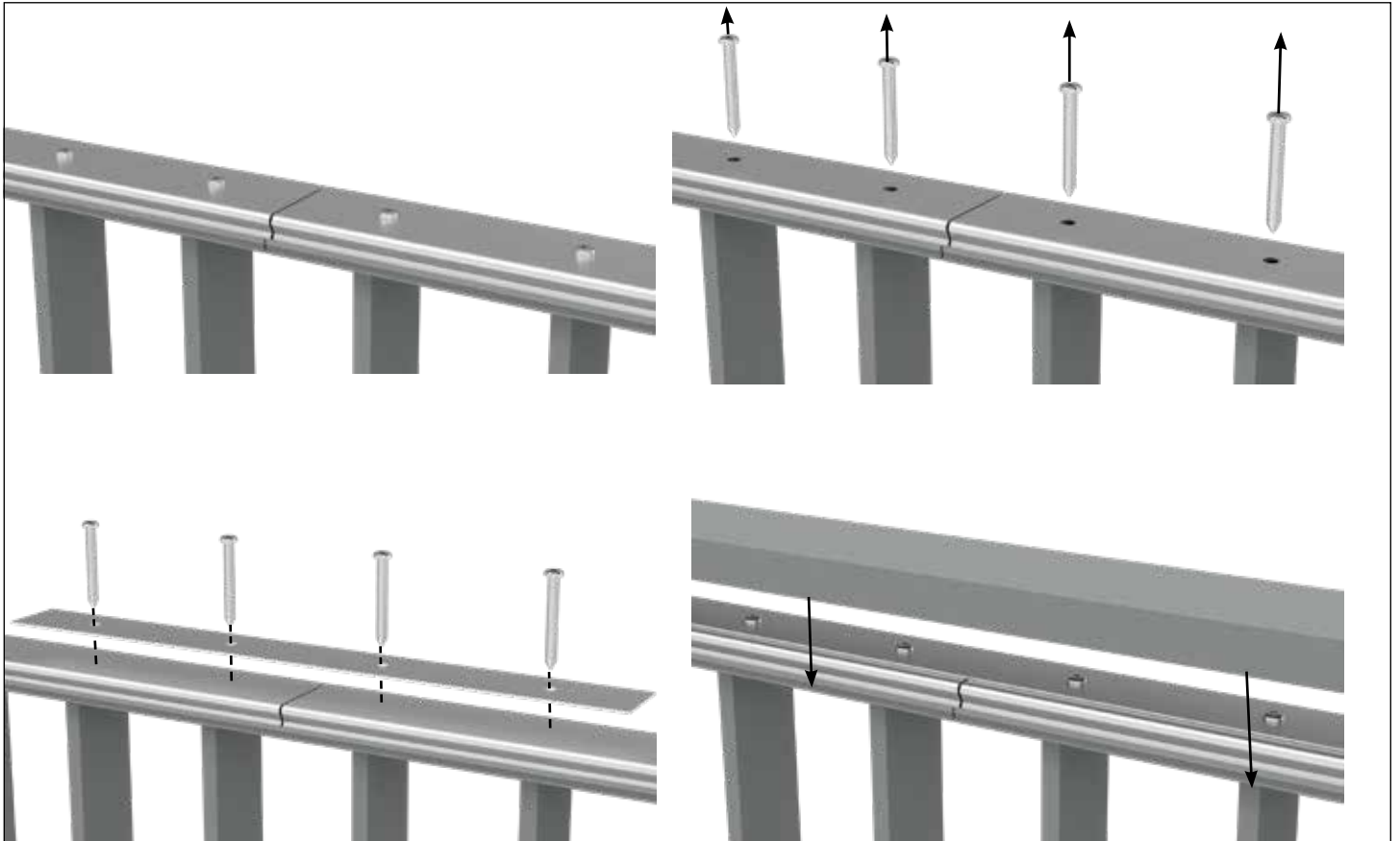

### ● Option 1: Inline Handrail Joiner

Inline Handrail Joiners are added after the installation of the Visor™ balustrade panels and prior to snap-fixing the Handrail into position. Inline Joiners are to be used when joining two Undercapping Plates together. Remove the four 14G x 50mm Panhead Screws from the top of adjacent panels (two from each panel) and affix the Inline Handrail Joiner using the same screws. 7mm holes may need to be drilled if the end Baluster spacings have been altered from original lengths.

Ensure the Handrail spans the join location of the Inline Handrail Joiner to offer further rigidity.

NOTE: The Face Mount Base and the Deck Mount Base do not require a joiner. Simply position the extrusions together end-to-end and affix to the substrate using appropriate fixtures.



# VISOR™ FABRICATION – APPENDIX 2

## HANDRAIL JOINERS

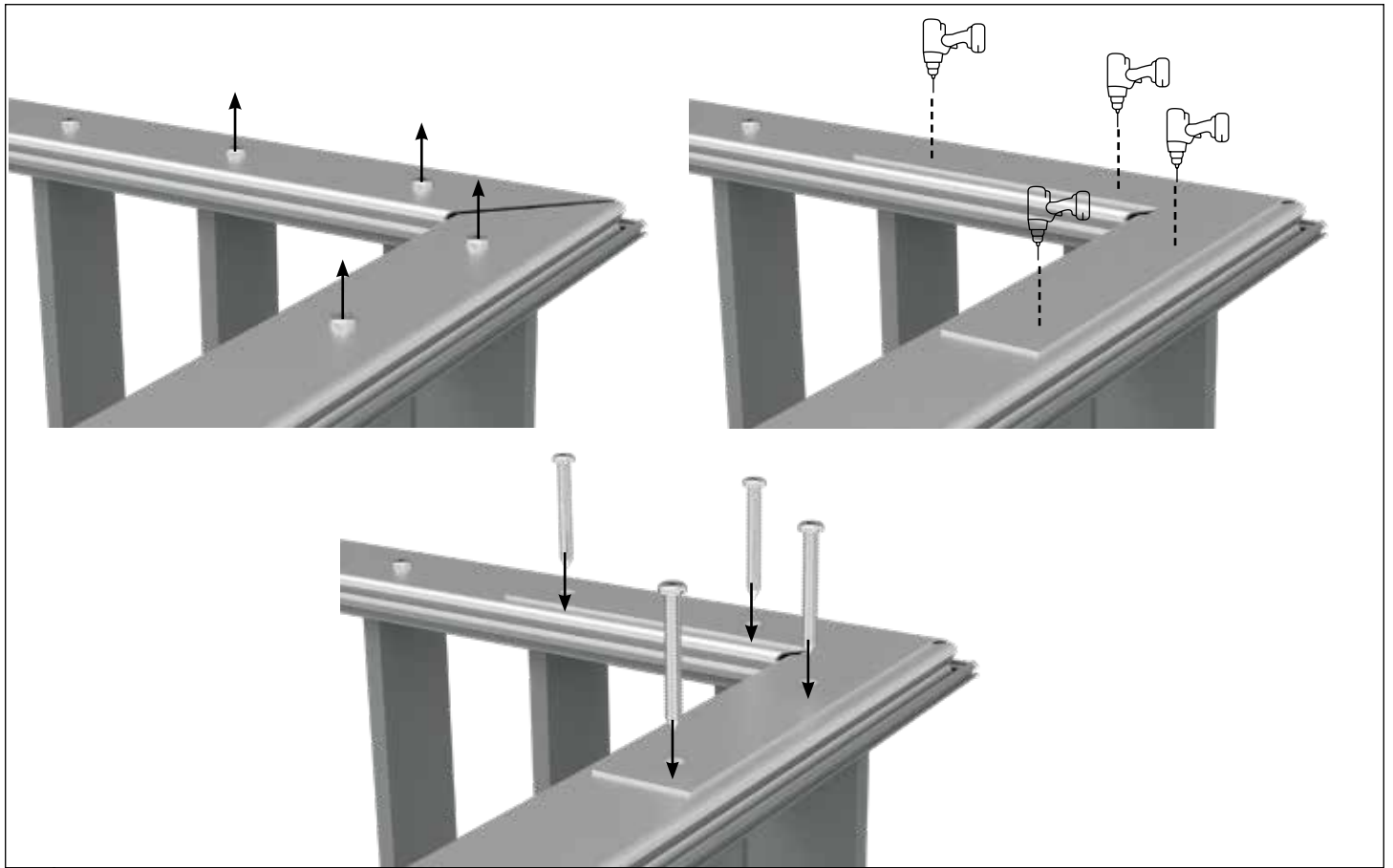

● Option 2: 90 Degree Handrail Joiner

A 90 Degree Handrail Joiner is added after the installation of the Visor™ balustrade panels and prior to snap-fixing the Handrail into position. Remove the four 14G x 50mm Panhead Screws from the top of the mitred adjacent panels (two from each panel). Drill 4x 7mm holes to the 90 Degree Handrail Joiner in line with the existing screw holes. Reapply screws to engage the Baluster through the Friction Insert and 90 Degree Joiner.

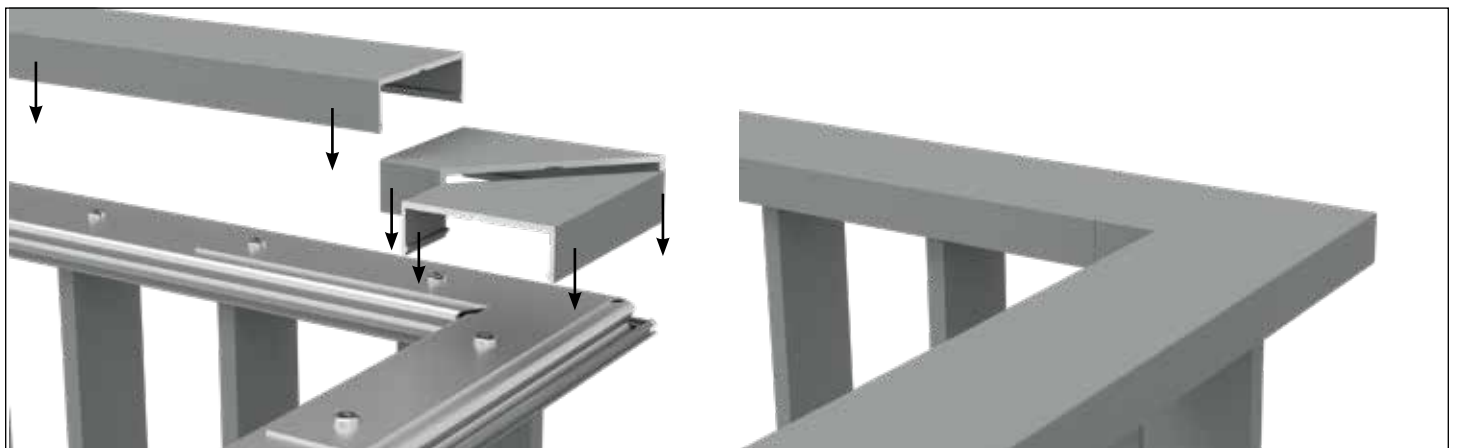

● Cut the handrail at a mitre to suit the Undercapping, and cut the other end central to the first Baluster giving two short corner handrail sections. Affix both mitred Handrail sections by clipping/sliding into position. Measure, cut and affix the remaining Handrail with straight cuts.

NOTE: The Face Mount Base and the Deck Mount Base do not require a joiner. Simply position the extrusions together end-to-end and affix to the substrate using appropriate fixtures (see Appendix 3 and 4).





# VISOR™ FABRICATION – APPENDIX 3

## FACE MOUNT BASE MITRED CORNERS

	Baluster Spacing	Cut Length
MIN	20mm	7mm
MAX	60mm	35mm

\*CONTACT US FOR OUR FREE EXCEL MITRE CUTTING CALCULATOR!

● Option 1: External Corners

	Baluster Spacing	Cut Length
MIN	10mm	72mm
MAX	50mm	100mm

\*CONTACT US FOR OUR FREE EXCEL MITRE CUTTING CALCULATOR!

● Option 2: Internal Corners



# VISOR™ FABRICATION – APPENDIX 4

## DECK MOUNT BASE MITRED CORNERS

	Baluster Spacing	Cut Length
MIN	20mm	40mm
MAX	60mm	11mm

\*CONTACT US FOR OUR FREE EXCEL MITRE CUTTING CALCULATOR!

● Option 1: External Corners

	Baluster Spacing	Cut Length
MIN	10mm	119mm
MAX	50mm	147mm

\*CONTACT US FOR OUR FREE EXCEL MITRE CUTTING CALCULATOR!

● Option 2: Internal Corners

# VISOR™ FABRICATION – APPENDIX 5

## DECK MOUNT BASE DRAINAGE CONSIDERATIONS

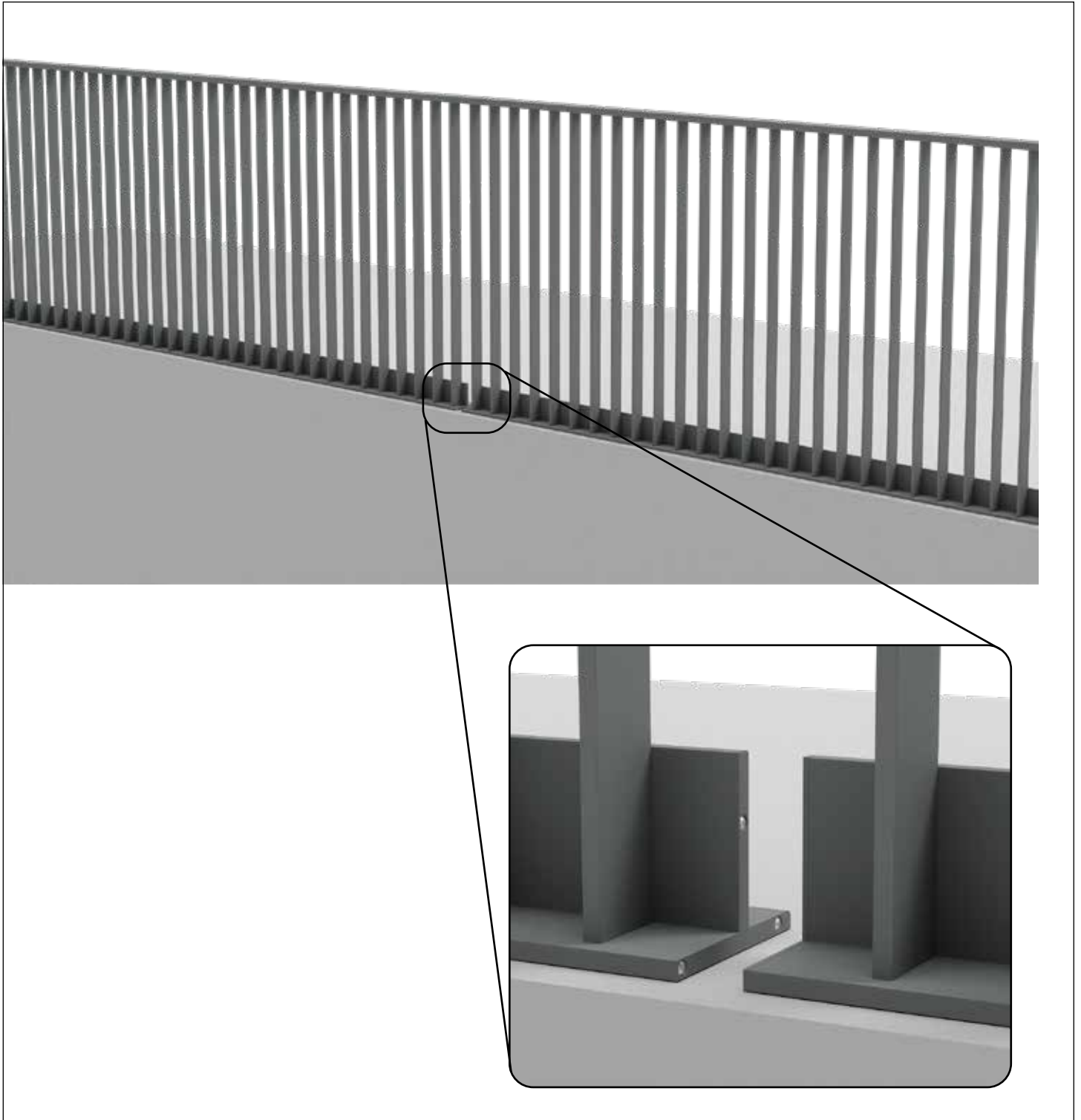

- For decks and balconies that require water drainage considerations, leave a 50mm gap in the Deck Mount Base, equally spaced between two Balusters.

Attach Deck Mount End Plates to each exposed base profile ends by drilling a 3.5mm hole and affixing with a colour matched 3.2mm Dia. aluminium pop rivet (not supplied).

Deck Mount Base fixtures to the substrate will be required on each side of this gap and the handrail will span this gap.



# ALUMINIUM BALUSTRADE INNOVATION

## Introduction

Our suite of aluminium systems sit at the intersection of style and innovation. Designed with labour saving technology in mind and non-weld assembly/installation, simply select post and handrail and then select between 5 infill styles.

All systems have engineer compliance certification. Contact us for details.

SAVE TIME AND  
MONEY WITHOUT  
COMPROMISE  
ON QUALITY  
OR STYLE.

## 01 STEP 1 / SELECT POST & HANDRAIL\*

- (A) Core drill or base plate posts
- (B) Face mount posts
- (C) Oval or rectangular handrails\* (\*not required for Barr balustrade)

## 02 STEP 2 / SELECT INFILL

*(same post & handrails used with all infills)*

- (A) Barr balustrade
- (B) AIRE™ Square picket baluster (16.5x16.5mm)
- (C) AIRE™ Vertical slat balustrade (65x16.5mm)
- (D) Horizontal slat balustrade (65x16.5mm)
- (E) Premium Perforated sheet

## 03 STEP 3 / INSTALL

Enjoy the benefits of non-weld assembly with a superb finish.





# 'MIX & MATCH' SYSTEMS

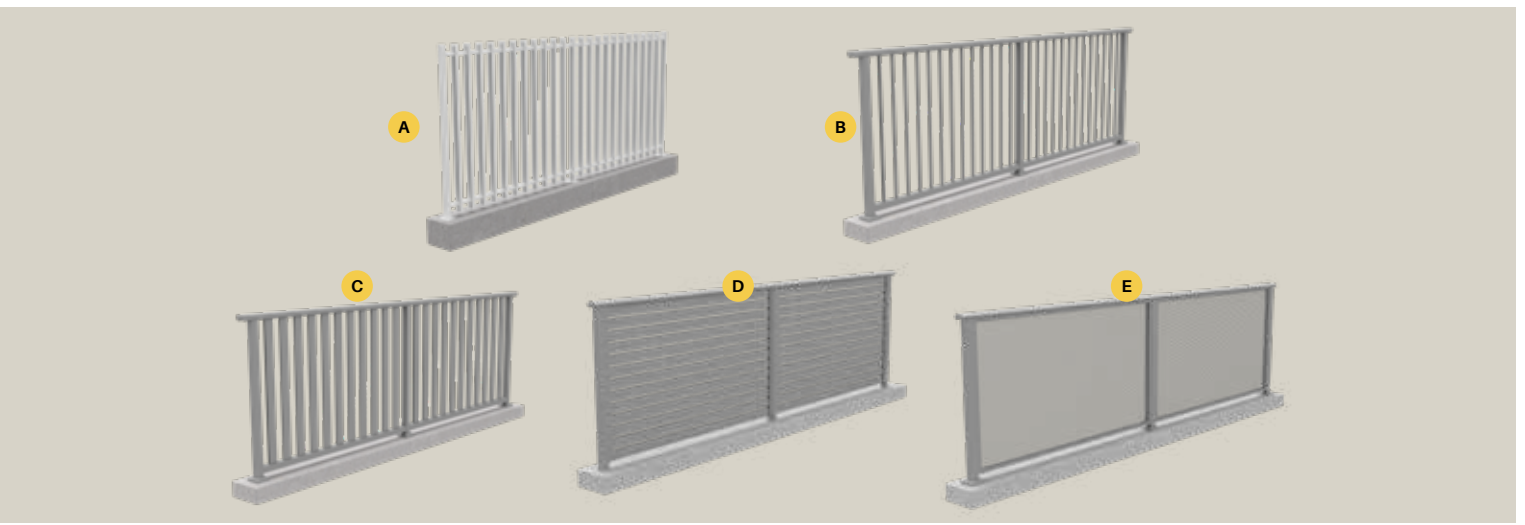
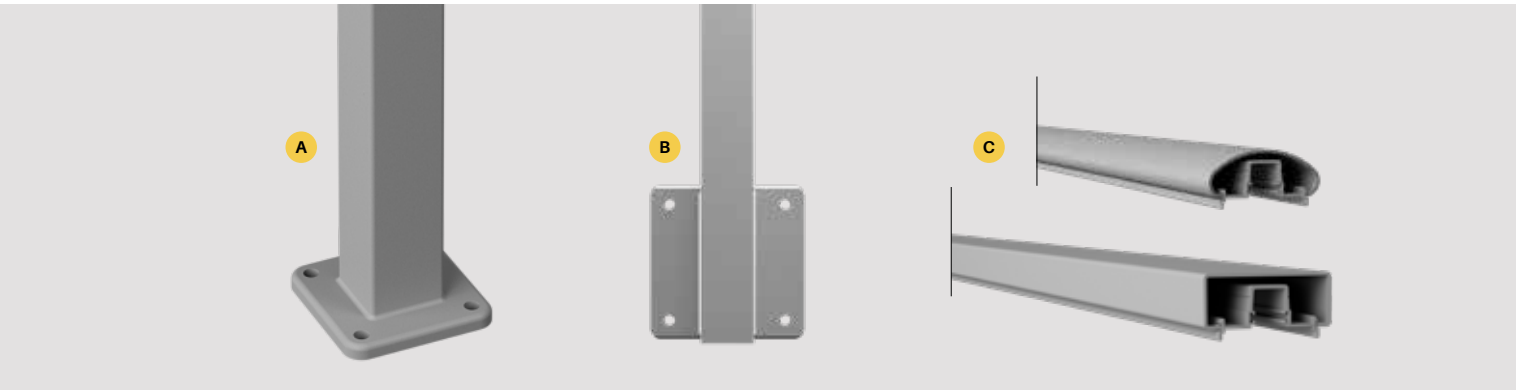

# BARR BALUSTRADE

## Why choose BARR?

Elevate aesthetics and functional living spaces with BARR – the brand new and ingeniously designed 50x25mm vertical baluster aluminium balustrade system. Pushing the boundaries of modern design and craftsmanship, we've revolutionised traditional balustrade systems.

- 1. STREAMLINED INTEGRATION**  
The horizontal top and bottom rails seamlessly pass through expertly machined holes in the balusters, ensuring a sleek appearance and superior structural integrity.
- 2. ROBUST ALUMINIUM BUILD**  
Durability meets design. Our balusters are crafted from high-grade aluminium, ensuring long-lasting performance without compromising on elegance.
- 3. SPACE-SAVVY DESIGN**  
With a slim 50x25mm profile, vertical balusters provide a visually expansive feel, making spaces look bigger and more open, while ensuring safety and sturdiness.
- 4. EASY INSTALLATION**  
Panels are fully welded and ready to install with slimline brackets at each end. Install utilising sturdy core drill, deck mount or face mount posts.
- 5. MAINTENANCE SIMPLICITY**  
With its corrosion-resistant properties, our aluminium balustrade system promises minimal upkeep, retaining its shine and strength for years to come.
- 6. COMPLIANCE**  
Contact us for engineer compliance certification.





# BARR BALUSTRADE

---

## 01 **BARR Core Drill**

50x50mm core drill posts featuring welded BARR 50x25mm balustrade infill panels

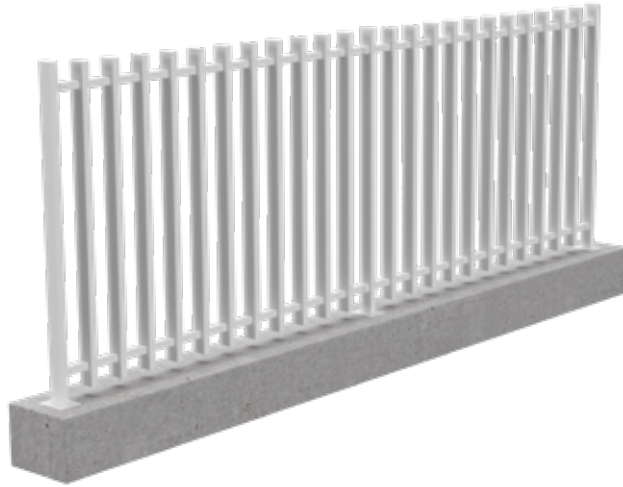

## 02 **BARR Base Plated**

50x50mm base plated posts featuring welded BARR 50x25mm balustrade infill panels

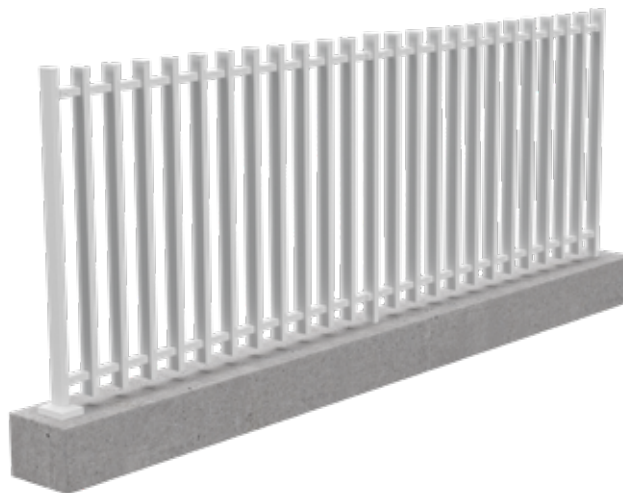

## 03 **BARR Face Mount**

50x50mm face mounts posts (including end and mid posts) with welded BARR 50x25mm balustrade infill panels

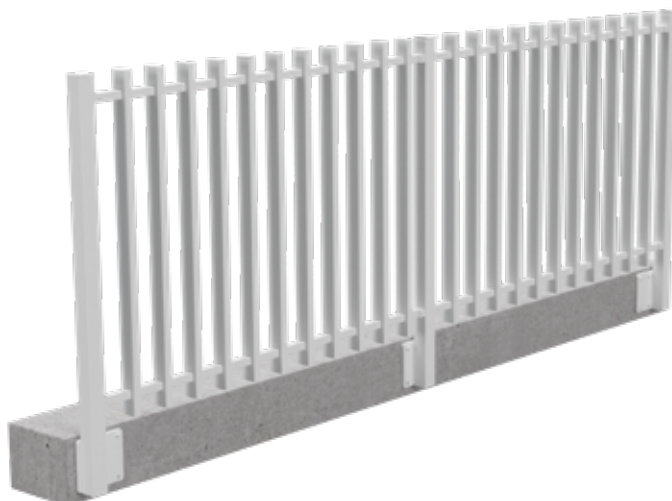



# FINISHES

## Our colour range

BARR is stocked in 2 popular balustrade powder coat finishes: Satin Black and Pearl White Gloss.

Satin black and pearl white continue to be the consistent colour palate for balustrade and seamlessly integrate into a variety of backgrounds. Pearl white is a growing trend in balustrade with the proliferation of Hamptons inspired design.

Genuine Interpon powder is used with Interpon D1000 manufacturer warranties provided.

BARR extrusions are produced to the chemical composition, mechanical property and dimensional tolerances in AS-NZS 1866:1997

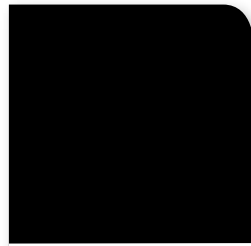

SATIN BLACK  
GN150A (B)

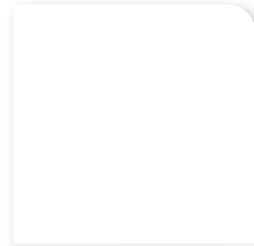

PEARL WHITE GLOSS  
GA078A (W)







# BARR BALUSTRADE

- 1 50x50mm posts: Core drill, base plated or face mount
- 2 Extended 'C' brackets
- 3 SS304 bracket fixing screws
- 4 1000mm high panel with welded 50x25mm balusters (or 1200mm high panel option for face mount installations)

## CORE DRILL

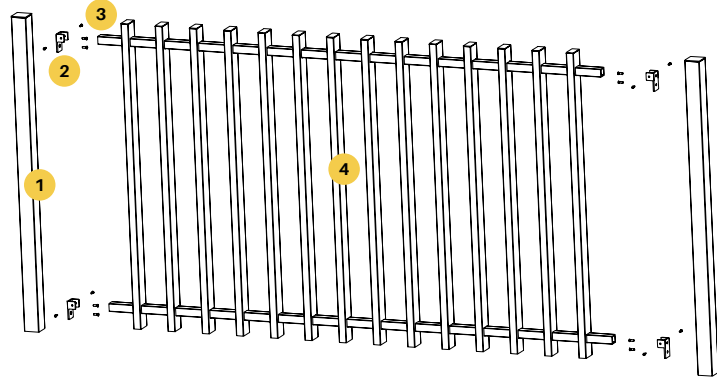

## BASE PLATED

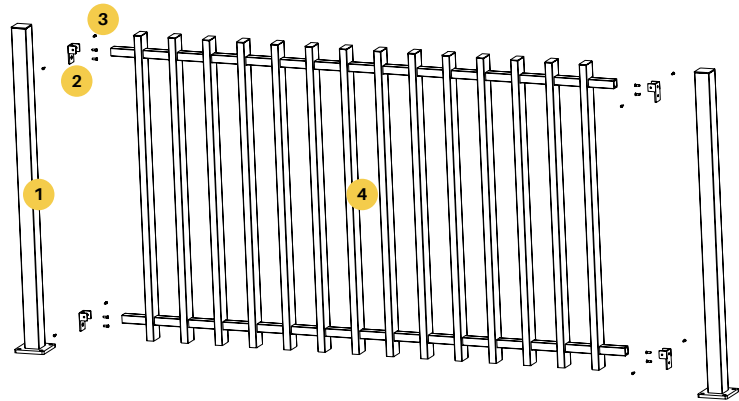

## FACE MOUNT

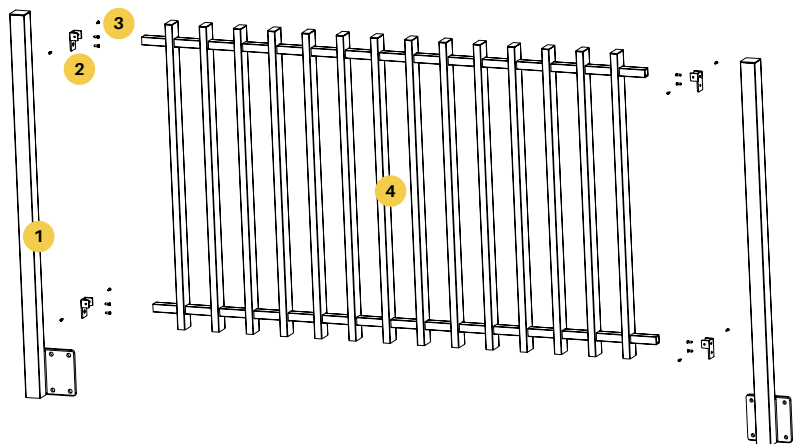



# BARR BALUSTRADE

## Full post with base plate (welded)

1050mm H

**Satin Black or Pearl White finish**

Order Code: AR-1050-FPBP-B (Black)

AR-1050-FPBP-W (White)

- Sturdy base plated post at 1050mm high overall
- 3.2mm wall thickness post: 50x50mm profile
- 100x100mm base plate 10mm thick welded on; 4 x 11mm diameter fixing holes
- Made from Alloy 6106 T6: premium & rigid alloy
- Aluminium top cap pre-inserted in each post

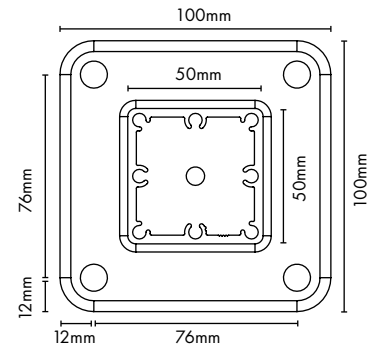
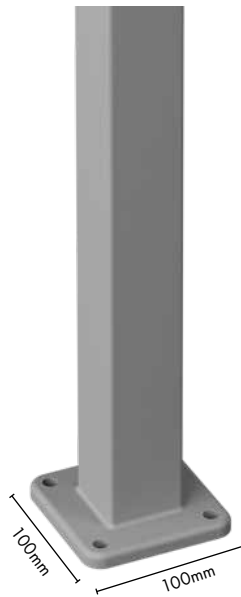

FINISHES

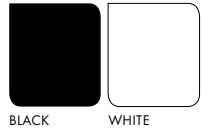

BLACK WHITE

## 5800mm long – Full post

50x50x3.2mm

**Satin Black or Pearl White finish**

Order Code: AR-5800-FP-B (Black)

AR-5800-FP-W (White)

- 5800mm long post: suits core drill installation
- Cut to required lengths
- 3.2mm wall thickness post: 50x50mm profile
- Made from Alloy 6106 T6: premium & rigid alloy
- Aluminium top cap sold separately
- Refer code: XP-TP-B (Black) or XP-TP-W (White)

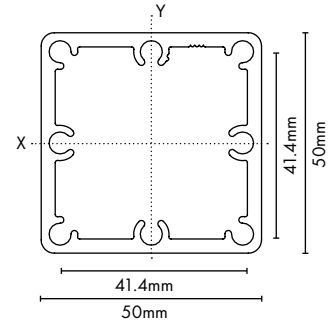

lxx = 214.10 x 10E3 mmE4  
lyy = 214.28 x 10E3 mmE4

FINISHES

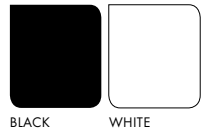

BLACK WHITE



# BARR BALUSTRADE

## Mid face mount post

1500mm H

**Satin Black or Pearl White finish**

Order Code: AR-1500-FMID-B (Black)

AR-1500-FMID-W (White)

- 1500mm long face mount MID post
- Heavy duty 50x50mm aluminium profile: 4mm wall post thickness
- 150x150mm welded on plate: 10mm thick
- 4 x 13mm diameter fixing holes
- Easily cut down height of post to required length
- Aluminium top plate included with post (top plates available separately if required (order code: XP-TP-B (black); XP-TP-W (white)))

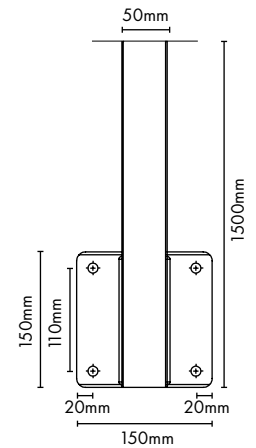
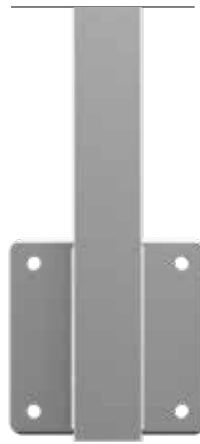

FINISHES

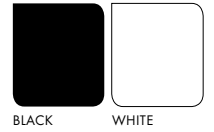

STEP 1

Install anchors ensuring alignment to post plate holes



STEP 2

Fix off with dome nuts if using threaded rod or lag screw anchors



STEP 3

Install BARR panels & brackets



STEP 4

Finished installation

## Face mount – 1 left & 1 right

1500mm H

**Satin Black or Pearl White finish**

Order Code: AR-1500-FMLR-B-2PK (Black)

AR-1500-FMLR-W-2PK (White)

- 1500mm long face mount END posts – LEFT & RIGHT
- Heavy duty 50x50mm aluminium profile: 4mm wall post thickness
- 160mmWx150Hmm welded on offset plates: 10mm thick
- 4 x 13mm diameter fixing holes
- Easily cut down height of post to required length
- Offset plates enable posts to be positioned at absolute ends of face mount installations
- Aluminium top plate included with post (top plates available separately if required (order code: XP-TP-B (black); XP-TP-W (white)))
- Sold as a 2 pack (left & right)

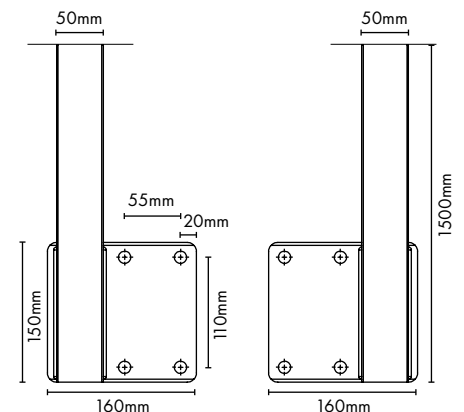

FINISHES





# BARR BALUSTRADE

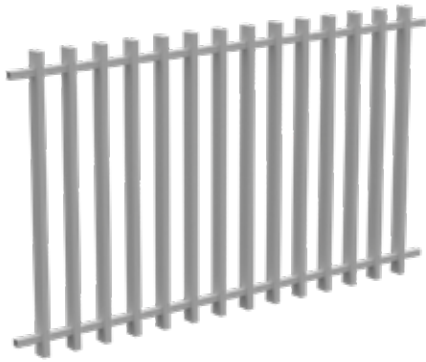

Satin black



Pearl white

## INSTALLATION TRADE TIP

Allow total bracket gap of 10mm per panel (5mm each side)

### BARR 50 x 25 Panel

1000MM H x 1733MM W

**Satin Black or Pearl White finish**

Order Code: **BR-PANEL-1733-1000-B/W**

- 1000mm high panel; aluminium alloy 6063-T6
- 50x25mm pickets/balusters with 25mm front/facing edge
- Sturdy 25x25x2.8mm horizontal top/bottom rails pass through the centre of punched pickets
- Pickets welded to horizontal rails
- Panel construction is very strong with rails passing through pickets
- 50x25mm picket provides the sought after seamless 'batten' look
- Aluminium powder coated cap pre-inserted in the top of each picket

**IMPORTANT NOTE:** For engineering compliance, the maximum allowable span is 1425mm centre to centre of post. BARR panels will require width adjustment from stocked panel size. Horizontal rails can be easily cut down with a dropsaw and appropriate blade. BARR Panels may also be used for boundary fencing therefore a wider width is stocked as standard to cater for that option also.

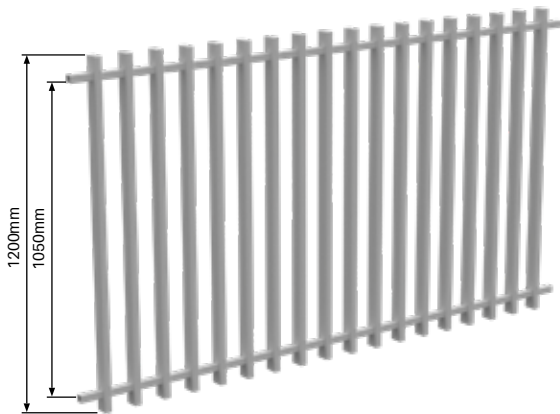
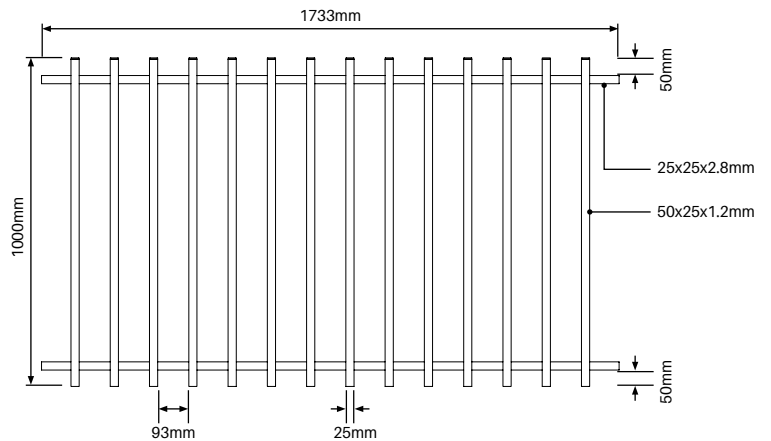

### BARR 50 x 25 Panel

1200MM H x 2205MM W

**Satin Black or Pearl White finish**

Order Code: **BR-PANEL-2205-1200-B/W**

- 1200mm high panel: aluminium alloy 6063 T6
- Same specifications as 1000mmH panels except 200mm higher
- Pre-inserted nylon cap in the top of each picket
- 1200mmH panel is an option for use with FACE MOUNT posts
- Sets the bottom rail under floor level so that only the top rail is visible when looking out
- Achieves the desirable minimalist 'floating batten' look

**IMPORTANT NOTE:** For engineering compliance, the maximum allowable span is 1425mm centre to centre of post. BARR panels will require width adjustment from stocked panel size. Horizontal rails can be easily cut down with a dropsaw and appropriate blade. BARR Panels may also be used for pool fencing at 1200mm high and are therefore stocked wider.



# BARR BALUSTRADE

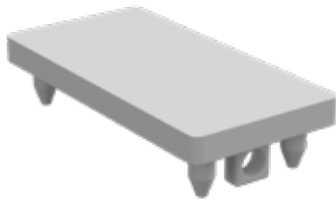

## BARR Top Cap

50 x 25 x 4MM

**Satin Black or Pearl White finish**

Order Code: BR-TCA-B/W

- Made from solid aluminium and CNC machined (not die cast aluminium)
- Optional extra 4mm thick aluminium powder coated top cap
- Presses into screw flutes in 50x25mm pickets
- 1000mmH panels have CNC aluminium picket caps pre-inserted. Optional extra BARR caps available for replacements.
- 1200mmH panels have nylon top caps pre-inserted. Remove nylon caps and replace with aluminium CNC powder coated top caps if desired.

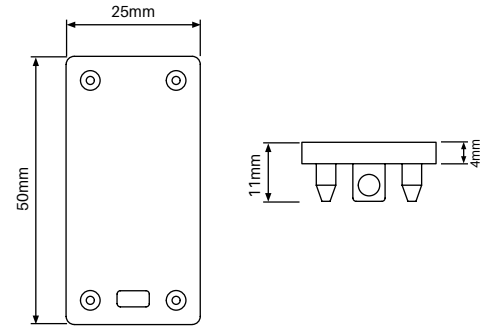

## 50x50mm post flat top plate

POWDER COATED ALUMINIUM

**Black or White finish**

Order Code: XP-TP-B/W

- Alloy ADC12 aluminium cap
- Press into 50x50mm post screw flutes

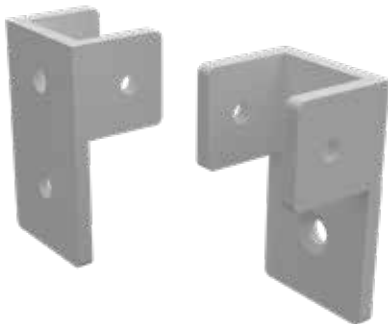

## BARR Extended 'C' Bracket Kit

4 PACK

**Satin Black or Pearl White finish**

Order Code: BR-BR60-B/W-4PK

- EXTENDED "C" bracket for neat fixing of panels to posts/wall
- Made from extruded aluminium
- Features a longer back leg allowing 2 x fixings to post/wall for extra strength
- Screws supplied for each bracket include 2 x countersunk SS304 screw for fixing to aluminium posts & 2 x panhead SS304 square drive screws for fixing the panels with the rails
- Sold as a pack of 4 x EXTENDED "C" brackets with matching screws

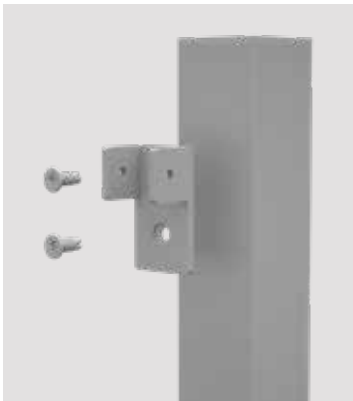
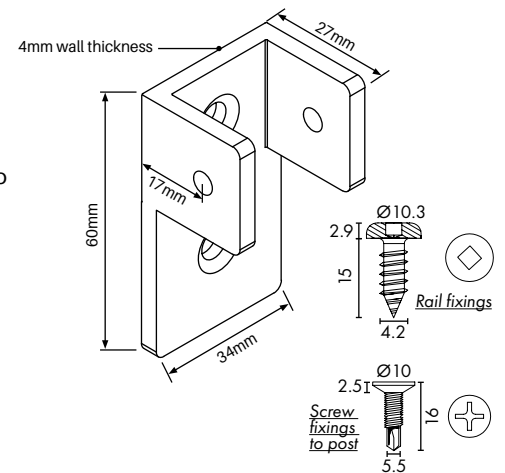

STEP 1

Fix brackets to posts

\*Rear bracket wall thickness is 4mm.  
Cut horizontal rails making allowance for bracket wall thickness.

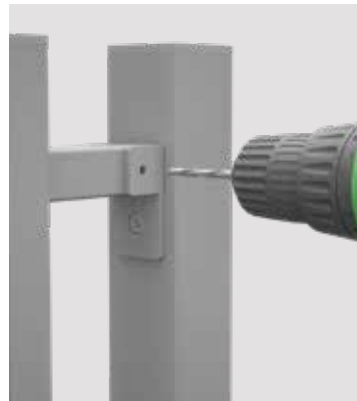

STEP 2

Pilot hole drill

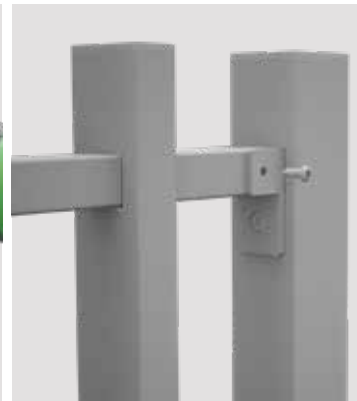

STEP 3

Fix off bracket to rail



STEP 4

Finished



# BARR BALUSTRADE

## 50x50mm post dress ring

POWDER COATED ALUMINIUM  
Satin Black or Pearl White finish

Order Code: XP-DR-B/W

- Suits 50x50mm core drill posts
- 100mm x 100mm outer – 52mm x 52mm inner

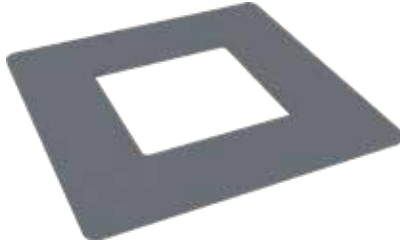

## Two part domical cover

POWDER COATED ALUMINIUM  
Satin Black or Pearl White finish

Order Code: XP-DC-2P-B/W

- Suits 50x50mm post with 100x100mm base plate
- 106x106mm outer – 52x52mm inner
- Alloy ADC12
- 30mm high
- Cover can be fitted after base plated posts installed

*Discreet screws fix two parts of cover together*

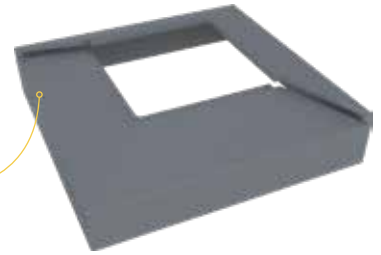

## Driver bit

Order Code: DB-PH3

- Driver bit to suit Phillips #3 screw head



## Square head driver bit

Order Code: DB-SQ3.4

- Driver bit to suit 3.4mm square screw head hole



## Timber fixing kit

4 PACK – SS316

Order Code: S-110LAG-4PK

- M10 x 110mm timber lag screws x4 with nuts and washers
- M10 fixing suits the 11mm hole diameter in base plated 50x50mm posts



## Concrete fixing kit

4 PACK – SS316

Order Code: S-120ROD-4PK

- M10 x 120mm concrete threaded rods x4 with nuts and washers
- Use with chemical anchor for stud fixing
- M10 fixing suits the 11mm hole diameter in base plated 50x50mm posts



# BARR BALUSTRADE



## Soudafix CA1400 Chemical anchor

280mL

Order Code: SOUD-CA1400

- High performance, two-component chemical anchoring resin for the pressure-free securing of anchoring rods, studs, treaded collars etc
- Easy to use and apply
- Fast cure (20°C=45min full cure; 30°C=25min full cure)
- Vinylester styrene free
- Can be used in damp concrete
- Apply with standard caulking gun

## Soudal heavy duty cartridge gun

Order Code: SOUD-GUN

- Heavy duty, steel trade quality cartridge gun
- Geared ratio 18:1 for smooth operation and easy application
- Dripless system feature automatically releases pressure to reduce mess/waste
- Suits 300ml silicone cartridges and 280ml chemical anchor



## Horseshoe Packers

20 PACK

**Black finish**

Order Code: HSP-75X38-1MM-20PK

1mm thick

HSP-75X38-3MM-20PK

3mm thick

- 38mm wide x 75mm long horseshoe packers
- 10.5mm slot
- Available in 1mm or 3mm thick (20 per pack)
- Durable black solid polypropylene
- Handy for levelling adjustments while installing
- Easy to cut down to required length

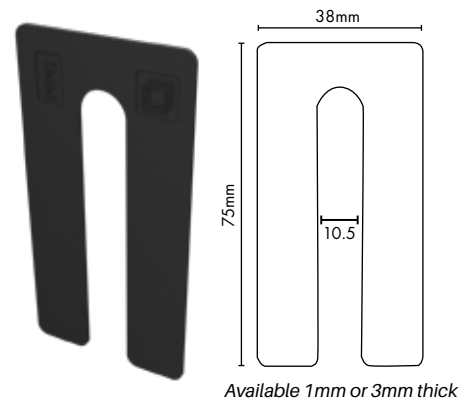

## Touch Up Paint

150g SPRAY CAN

**Black and Pearl White finish**

Order Code: PAINT-B (Black)

PAINT-W (White)

- Colour match touch up paint







# BARR BALUSTRADE

## M12 dome nut

PACK OF 4 – SS316

**Black or Mill finish**

Order Code: **GS-DN-4PK-B (Black)**

**GS-DN-4PK (Silver)**

- 4x dome nuts & 4x split washers
- Suits M12 thread

*Silver recommended for white powder coat installations.  
Black recommended for black powder coat installations.*

**IMPORTANT NOTE:** M12 fixings suits 13mm hole diameter in FACE MOUNTED posts. Cannot be used for fixing of base plated posts (which have 11mm diameter holes in base plates).



### FINISHES



MATT BLACK MILL



## M 12 FIXINGS

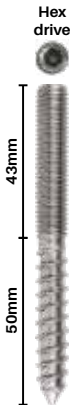

### 93mm lag screw

SS304

**M12 thread**

Order Code: **GS093LAG**

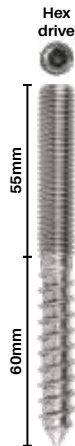

### 115mm lag screw

SS304

**M12 thread**

Order Code: **GS115LAG**



### 160mm lag screw

SS304

**M12 thread**

Order Code: **GS160LAG**

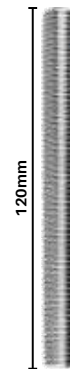

### 120mm threaded rod

SS304

**M12 thread**

Order Code: **GS120ROD**

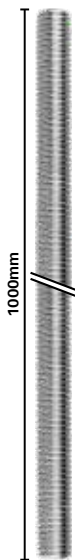

### 1000mm threaded rod

SS304

**M12 thread**











Order Code: **GS1000ROD**





**NOTE – Select finish code:**  
(EG AR-1050-FPBP-B for black)

# ORDER CODES

Order Code	Description	Colours
AR-1050-FPBP-B/W	1050mm high – full post with base plate (welded)	 
AR-5800-FP-B/W	5800mm long – full post	 
AR-1500-FMID-B/W	Mid face mount post – 1500mm H	 
AR-1500-FMLR-B/W-2PK	Face mount – left & right – 1500mm H	 
BR-PANEL-1733-1000-B/W	Barr 50 x 25 panel – 1000mm H x 1733mm W	 
BR-PANEL-2205-1200-B/W	Barr 50 x 25 panel – 1200mm H x 2205mm W	 
BR-TCA-B/W	Barr top cap	 
XP-TP-B/W	50 x 50mm post flat top plate	 
BR-BR60-B/W-4PK	Barr extended 'C' bracket kit	 
XP-DR-B/W	50 x 50mm post dress ring	 
XP-DC-2P-B/W	Two part domical cover	 
DB-PH3	Phillips #3 driver bit	
DB-SQ3.4	Square head driver bit	
S-110LAG-4PK	M10 x 110mm long timber lag screw – 4 pack	
S-120ROD-4PK	M10 x 120mm thread rod with nuts/washers – 4 pack	
SOUD-CA1400	Soudafix CA1400 chemical anchor	
SOUD-GUN	Soudal heavy duty cartridge gun	
PAINT-B/W	Touch up paint	 
HSP-75X38-1MM-20PK	Horseshoe packers – 1mm thick	
HSP-75X38-3MM-20PK	Horseshoe packers – 3mm thick	
GS-DN-4PK-B/S	M12 dome nut – pack of 4	 

 MATT BLACK  MATT WHITE  MILL



# AIRE™

## Why choose AIRE™?

AIRE™ is a complete aluminium picket balustrade system featuring innovative patented non-weld technology and is ideally suited for new builds or renovations. This stunning system features either vertical 16.5mm square or 65x16.5mm slat balusters coupled with sturdy 50x50mm posts and the option of either a rectangular or oval handrail.

Careful design considerations ensure the system seamlessly integrates providing a complete aluminium balustrade suite that is easy to assemble and install in either core drill or base plated application.

The system is stocked in 3 popular powder coated finishes – satin black, monument matt and pearl white gloss. It is also available in mill finish allowing customisation of powder coat colour. Pre-powder coated material can be cut to required lengths and assembled onsite or in a factory. The installation process has been carefully considered with component parts designed to maximise visual appeal while still ensuring ease of install.

The AIRE™ system is the result of significant research and development coupled with extensive load testing by accredited NATA testing facilities. Importantly, engineer compliance certification is available.

AIRE™ is a game changer in aluminium picket balustrade.

## Certification

Certificate of Compliance to load test requirements of AS/NZS 1170.0, AS/NZS 1170.1 and NCC2022. Contact us for engineering information.

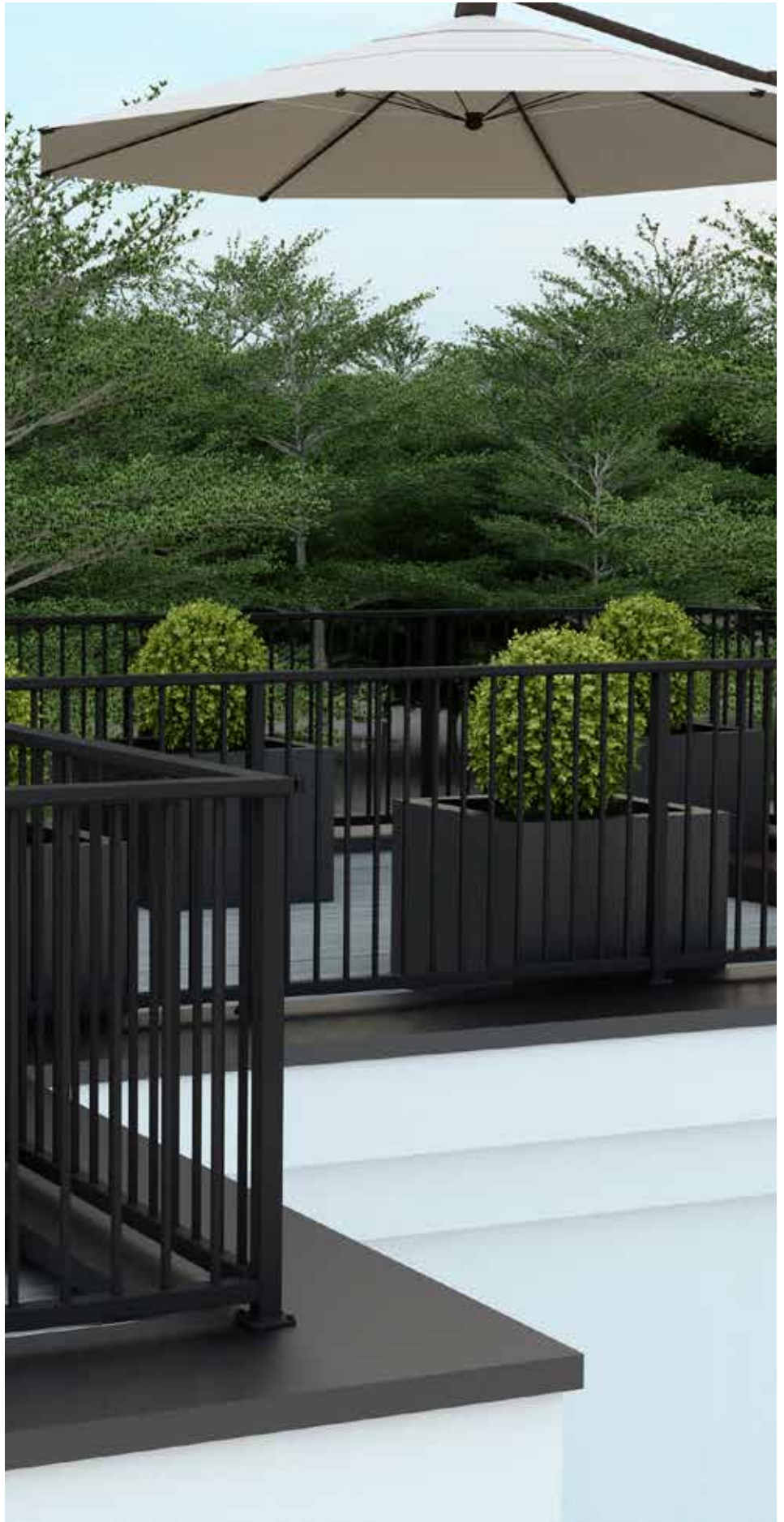



## STYLES OF AIRE™

---



### 01 AIRE™ Picket Full

The ultimate in picket balustrade – featuring 16.5x16.5mm square balusters with oval or rectangular handrail option.



### 02 AIRE™ Picket 3-Rail

Features a stylish midrail design incorporating 16.5x16.5mm square balusters and choice of oval or rectangular handrail.



### 03 AIRE™ Slat Full

Vertical slat 65x16.5mm slat balusters with 64mm gap spacing. Increasingly popular having regard to Hamptons inspired design.



### 04 AIRE™ Slat 3-Rail

Midrail option for 65x16.5mm vertical slat balustrade.



### 05 AIRE™ balustrade featuring face mount posts

Face mount posts feature (i) offset plates for installation at end of runs and (ii) centrally positioned plates for mid spans.



# FINISHES

## Our colour range

AIRE™ is stocked in 3 popular balustrade powder coat finishes: Satin Black, Monument Matt and Pearl White Gloss. Mill finish is also available enabling customisation to any desired powder coat finish.

Satin black and monument matt continue to be the consistent colour palate for balustrade and seamlessly integrate into a variety of backgrounds. Pearl White is a growing trend in balustrade with the proliferation of Hamptons and coastal living inspired design.

Genuine Interpon powder is used with Interpon D1000 manufacturer warranties provided.

AIRE™ extrusions are produced to the chemical composition, mechanical property and dimensional tolerances in AS-NZS 1866:1997

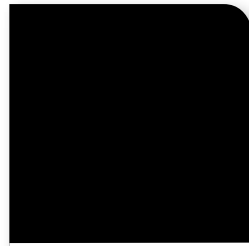

SATIN BLACK  
GN150A (B)

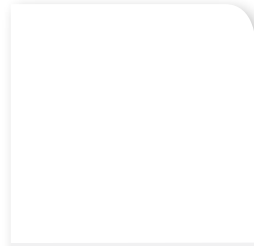

PEARL WHITE GLOSS  
GA078A (W)



MONUMENT MATT  
GL229A (MN)



MILL (M)  
Ready to powder coat





# AIRE™

- 1 **75x30mm top rail**  
(available oval or rectangle profile)
- 2 **Undercapping rail**
- 3 **75x30mm end cap**
- 4 **10gx16mm fixing screw for end cap**
- 5 **Snap in spacers**
- 6 **12gx20mm hex flange self drilling screw**
- 7 **16.5x16.5mm square pickets/balusters**
- 8 **Punched insert (92.5mm gap spacing)**
- 9 **45x45mm bottom rail**  
(also used as midrail for 3 rail installations)
- 10 **12gx25mm screws for:**  
1) Fixing rail mounting plates to posts  
(\*\*for fixing to aluminium posts. Use different/appropriate screws if fixing to timber/steel etc)  
2) Bottom rail locking screen  
3) Fixing undercapping rail to posts
- 11 **Mounting plates**
- 12 **12gx50mm screws for fixing mounting plates to bottom rail**
- 13 **50x50 AIRE™ post**  
(core drill, welded base plate or face mount posts)
- 14 **2 part domical cover**  
(\*\*if using base plated posts; use dress ring if core drill post)

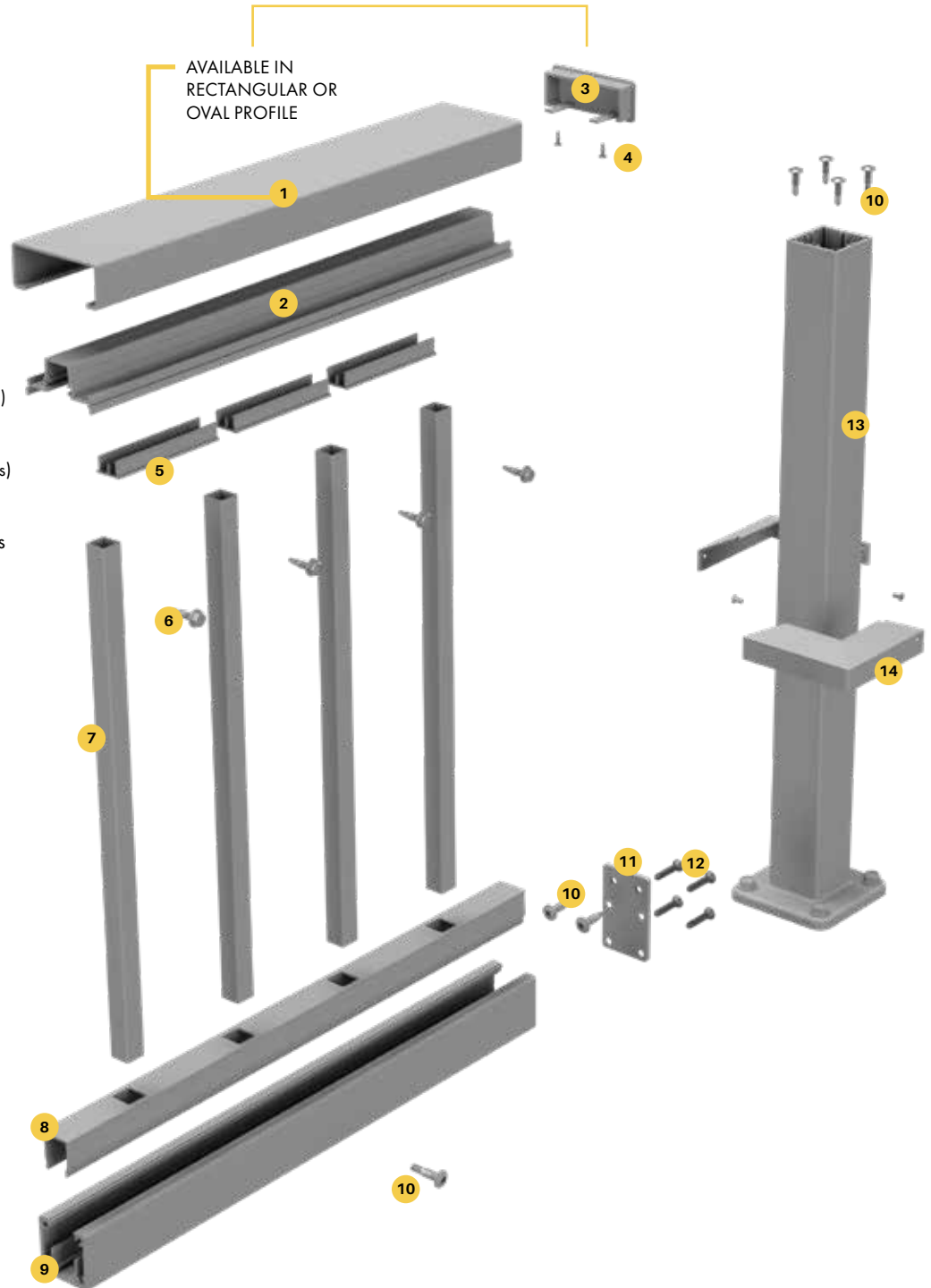

# AIRE™ SLAT

## AIRE™ slat range

Versatile design providing the sought after Hamptons look with 65x16mm vertical slat balusters. Also, achieve a stunning colonial look with the '3 rail configuration' by incorporating a midrail.

- ✔ Complete balustrade system featuring non-weld technology
- ✔ Core drill, base plated or face mount application
- ✔ Pre-powder coated stock is easily assembled & installed
- ✔ Option for raked installation for staircases
- ✔ Compliance certification available

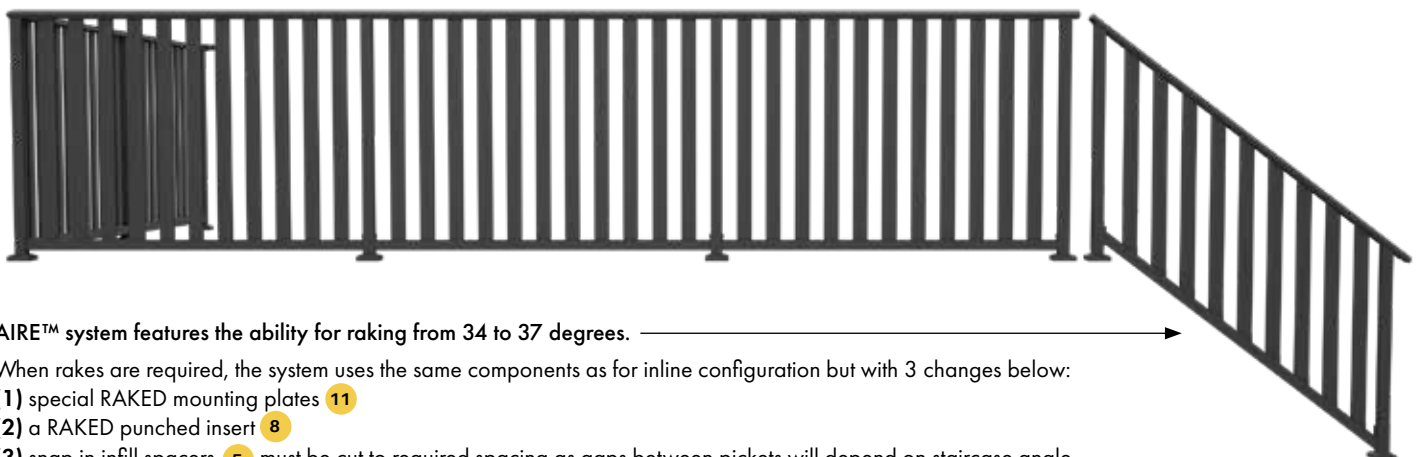
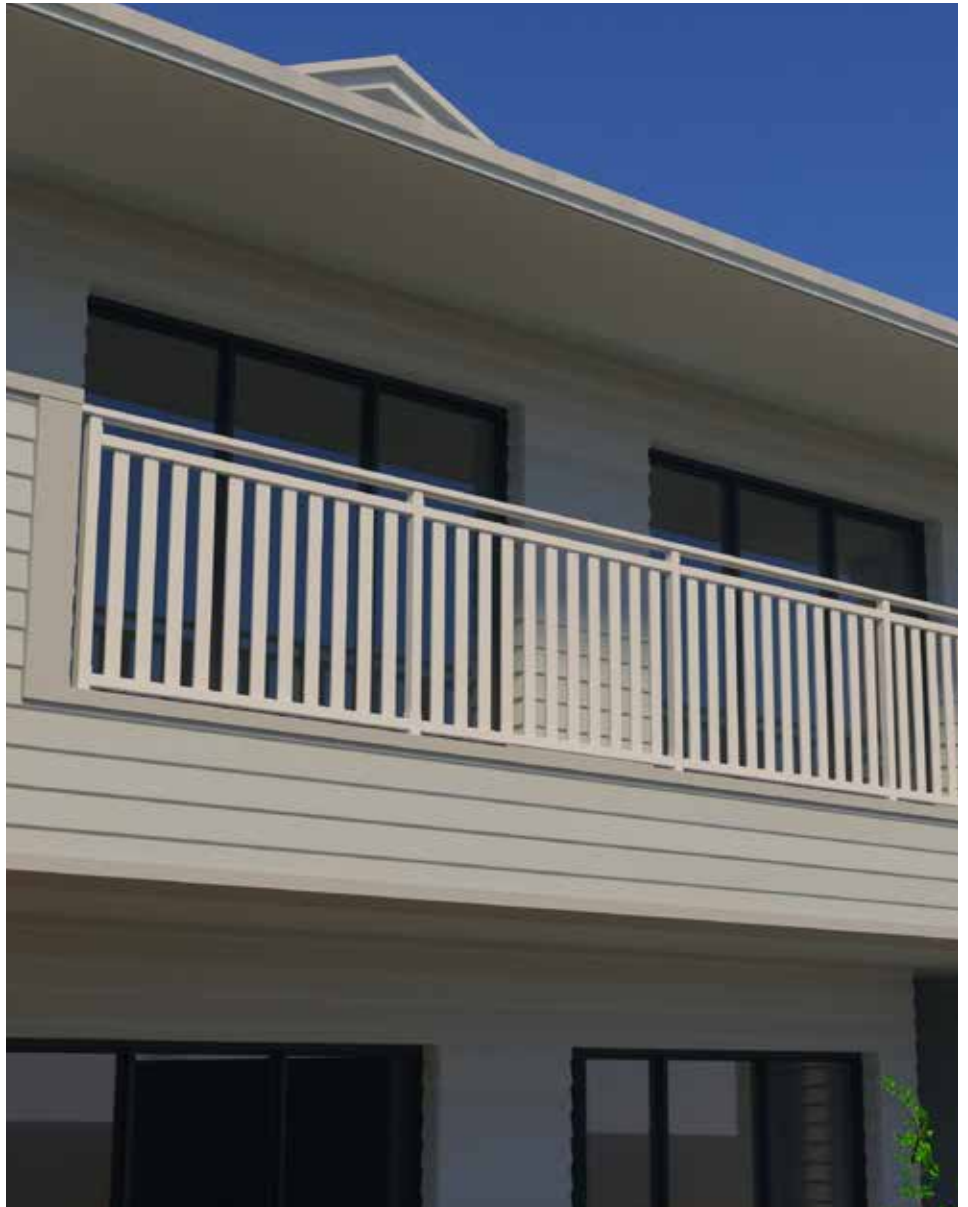

AIRE™ system features the ability for raking from 34 to 37 degrees.

When rakes are required, the system uses the same components as for inline configuration but with 3 changes below:

- (1) special RAKED mounting plates **11**
- (2) a RAKED punched insert **8**
- (3) snap in infill spacers **5** must be cut to required spacing as gaps between pickets will depend on staircase angle.

These 3 items are available as stock items.

For the top of posts, simply cut at required angle and then screw fix on undercapping rail **2**





# AIRE™

- 1 **75x30mm top rail**  
(available oval or rectangle profile)
- 2 **Undercapping rail**
- 3 **75x30mm end cap**  
(available to suit oval or rectangle profile)
- 4 **10gx16mm fixing screw for end cap**
- 5 **Snap in spacers**
- 6 **12gx20mm hex flange self drilling screw**
- 7 **65x16.5mm slat balusters**
- 8 **Punched insert (64mm gap spacing)**
- 9 **45x45mm bottom rail**  
(also used as midrail for 3 rail installations)
- 10 **12gx25mm screws for:**  
1) Fixing rail mounting plates to posts  
(\*for fixing to aluminium posts. Use different/appropriate screws if fixing to timber/steel etc)  
2) Bottom rail locking screen  
3) Fixing undercapping rail to posts
- 11 **Mounting plates**
- 12 **12gx50mm screws for fixing mounting plates to bottom rail**
- 13 **50x50 AIRE™ post**  
(core drill, welded base plate or face mount posts)
- 14 **2 part domical cover**  
(\*if using base plated posts; use dress ring if core drill post)

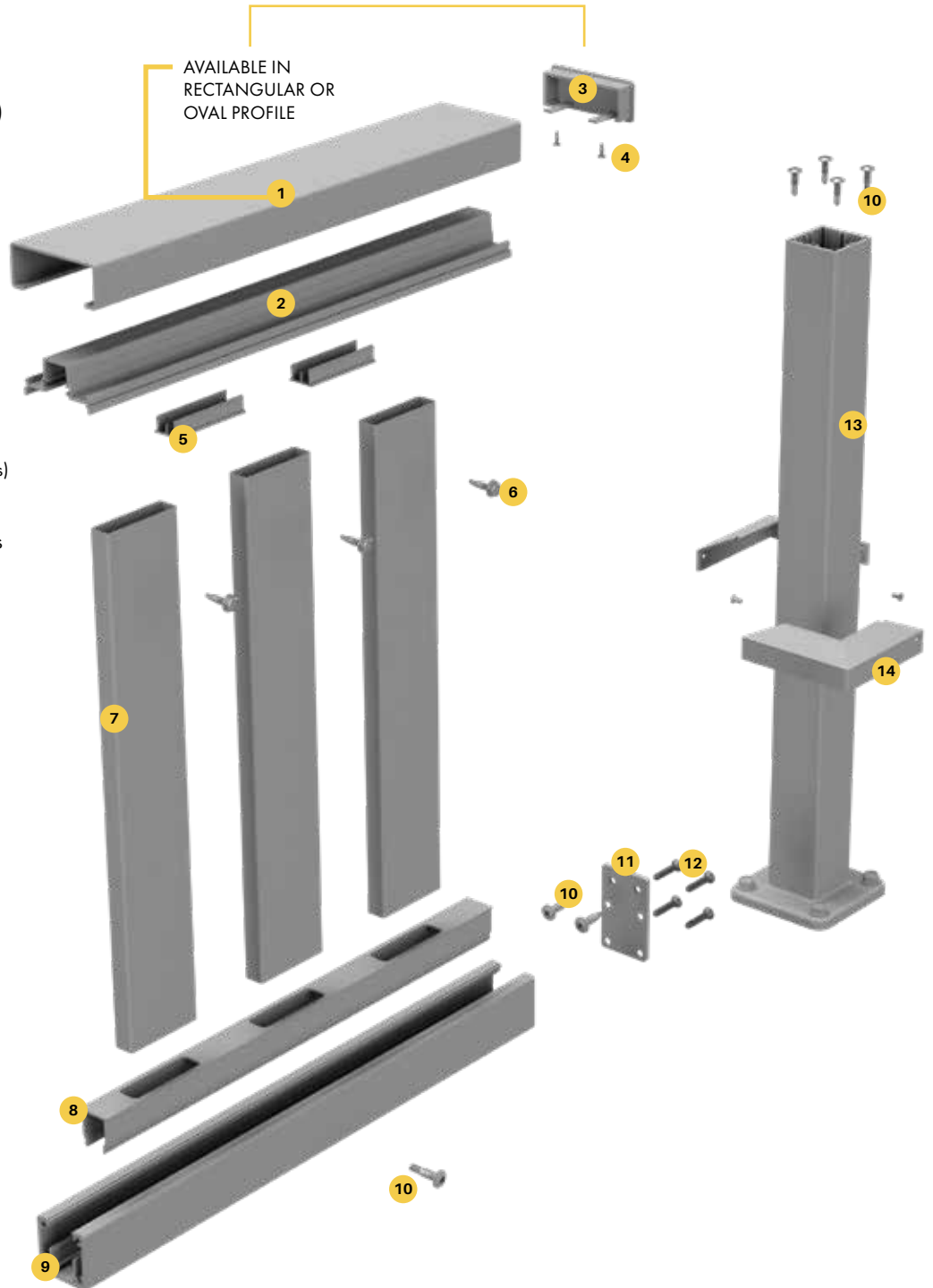



# AIRE™

## Full post with base plate (welded)

1050mm H

**Satin Black, Monument Matt,  
Pearl White Gloss or Mill finish**

Order Code: AR-1050-FPBP-B (Black)

AR-1050-FPBP-MN (Monument)

AR-1050-FPBP-W (White)

AR-1050-FPBP-M (Mill)

- Sturdy base plated post at 1050mm high overall
- Simply cut top of post to reduce height if needed
- Made from Alloy 6106 T6: premium & rigid alloy
- 3.2mm wall thickness post: 50x50mm profile
- 100x100mm base plate 10mm thick welded on;
- 4 x 11mm diameter fixing holes
- Screw flutes in extrusion allow non-weld affixing of top rail

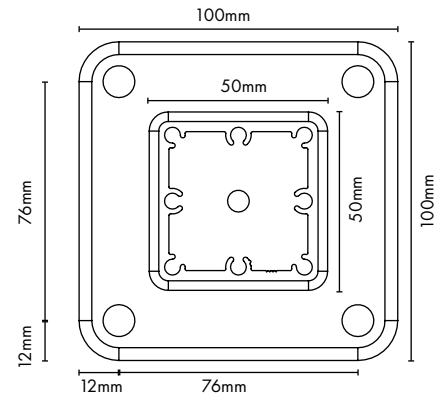
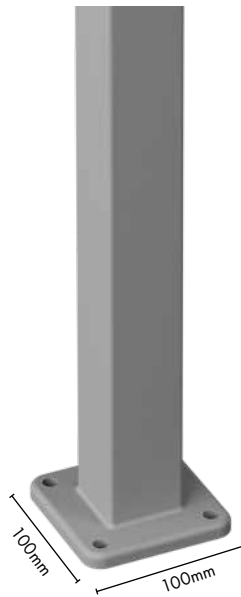

### FINISHES



## 5800mm long – Full post

50x50x3.2mm

**Satin Black, Monument Matt,  
Pearl White Gloss or Mill finish**

Order Code: AR-5800-FP-B (Black)

AR-5800-FP-MN (Monument)

AR-5800-FP-W (White)

AR-5800-FP-M (Mill)

- 5800mm long post: suits core drill installation
- Cut to required lengths
- Made from Alloy 6106 T6: premium & rigid alloy
- 3.2mm wall thickness post: 50x50mm profile
- Screw flutes in extrusion allow non-weld affixing of top rail

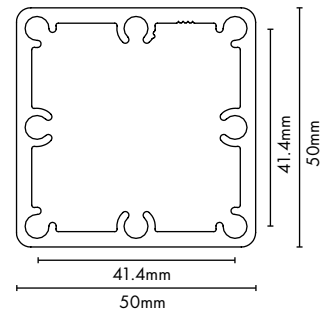

lxx = 214.10 x 10E3 mmE4  
lyy = 214.28 x 10E3 mmE4

### FINISHES



## Half post

50x25x3mm

**Satin Black, Monument Matt, White or Mill finish**

Order Code: A50-1400D-HALF-B (Black)

A50-1400D-HALF-MN (Monument)

A50-1400D-HALF-W (White)

A50-1400D-HALF-M (Mill)

A50-5800D-HALF-B (Black)

A50-5800D-HALF-MN (Monument)

A50-5800D-HALF-W (White)

A50-5800D-HALF-M (Mill)

- 50x25mm half post available 1400mm or 5800mm long
- easily cut to required length
- 3mm rear wall thickness
- Use at start or end of spans with half post fixed to a wall or existing post
- Screw fix off sideways to structure via recessed post cavity. Infill snaps into cavity to hide fixings
- Handrail undercapping rail screw fixes into the 2 x screw flutes in half post
- Made from alloy 6106 T6

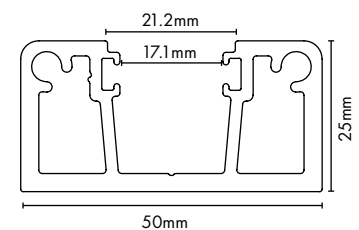

lxx = 32.82 x 10E3 mmE4  
lyy = 130.40 x 10E3 mmE4

### FINISHES





# AIRE™

## Post infill

1400mm long

**Satin Black, Monument Matt,  
Pearl White Gloss or Mill finish**

Order Code: **A50-1400-INF-B (Black)**

**A50-1400-INF-MN (Monument)**

**A50-1400-INF-W (White)**

**A50-1400-INF-B (Mill)**

- Snap in infill mates with half post
- Easily cut infill to required post cavity length
- Infill covers half post screw fixings
- Made from alloy 6063 T6

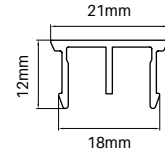

### FINISHES



BLACK



MONUMENT



WHITE



MILL



### STEP 1

Position half post against wall/post and screw fix. Pilot hole drilling required.

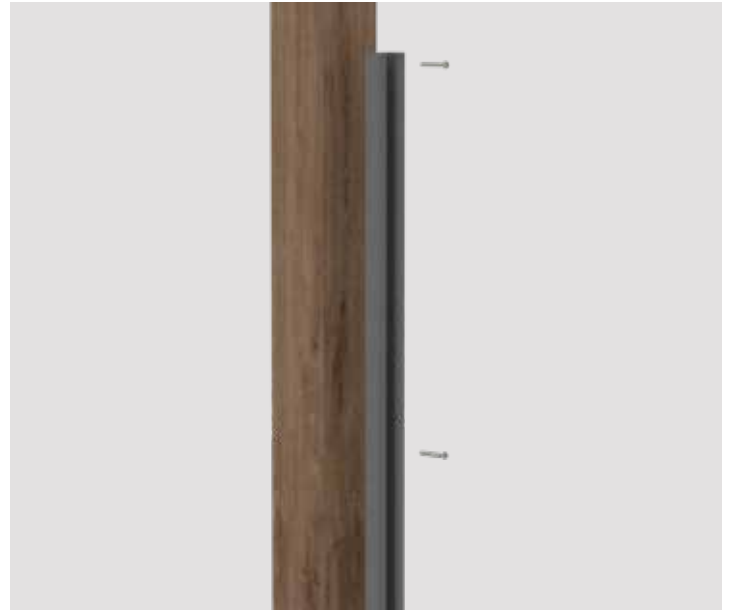

### STEP 2

Recommended minimum of 3 x fixings to structure.



### STEP 3

Snap infill into cavity to hide screw fixings.



### STEP 4

Half post installed - Handrail undercapping screw fixes into 2 x screw flutes in top of half post.





# AIRE™

## Mid face mount post

1500mm H

**Satin Black, Monument Matt, Pearl White Gloss or Mill finish**

Order Code: AR-1500-FMID-B (Black)

AR-1500-FMID-MN (Monument)

AR-1500-FMID-W (White)

AR-1500-FMID-M (Mill)

- 1500mm long face mount MID post
- Heavy duty 50x50mm aluminium profile: 4mm wall post thickness
- 150x150mm welded on plate: 10mm thick
- Made from alloy 6106T6: premium & rigid alloy
- 4 x 13mm diameter fixing holes
- Easily cut down height of post to required length

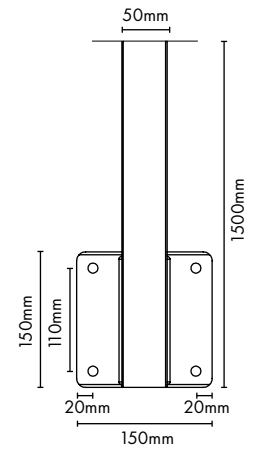
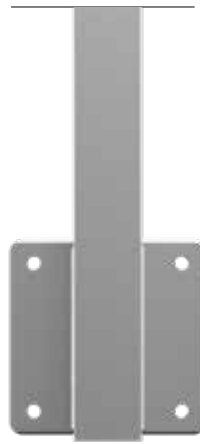

### FINISHES



STEP 1

Install anchors ensuring alignment to post fixing plate holes



STEP 2

Fix off with dome nuts if using threaded rod or lag screw anchors



STEP 3

Install AIRE™ panels, mounting plates & handrail



STEP 4

Finished installation

## Face mount – 1 left & 1 right

1500mm H

**Satin Black, Monument Matt, Pearl White Gloss or Mill finish**

Order Code: AR-1500-FMLR-B-2PK (Black)

AR-1500-FMLR-MN-2PK (Monument)

AR-1500-FMLR-W-2PK (White)

AR-1500-FMLR-M-2PK (Mill)

- 1500mm long face mount END posts - LEFT & RIGHT
- Heavy duty 50x50mm aluminium profile: 4mm wall post thickness
- 160mmWx150Hmm welded on offset plates: 10mm thick
- Made from alloy 6106T6: premium & rigid alloy
- 4 x 13mm diameter fixing holes
- Easily cut down height of post to required length
- Offset plates enable posts to be positioned at absolute ends of face mount installations
- Screw flutes in post extrusion allows for non-weld affixing of handrail
- Sold as a 2 pack (left & right)

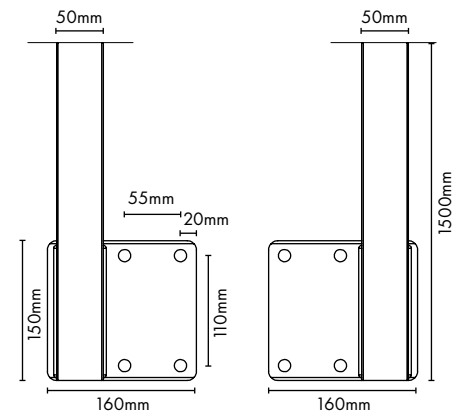
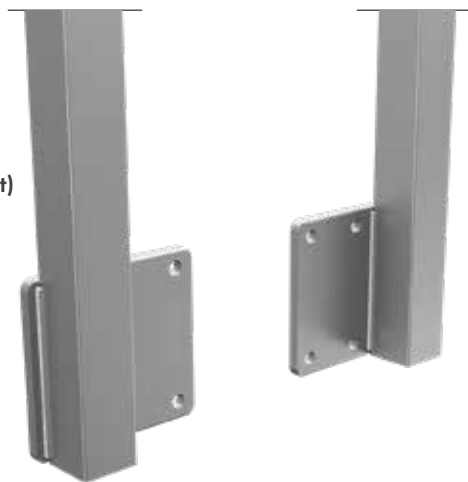

### FINISHES





# AIRE™

## AIRE™ Aluminium Balustrade

**5600mm long**

**Square picket baluster**

16.5 x 16.5 x 1.4mm

Sold in lots of 4 pickets

**Satin Black, Monument Matt,  
Pearl White Gloss or Mill finish**

Order Code: AR-5600-PB-B (Black)

AR-5600-PB-MN (Monument)

AR-5600-PB-W (White)

AR-5600-PB-M (Mill)

- 5600mm long picket/baluster  
Simply cut to required lengths
- Made from Alloy 6106 T6: premium & rigid alloy
- 1.4mm wall thickness baluster: 16.5x16.5mm profile
- Sold in bundles of 4

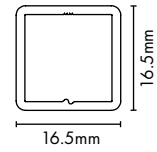
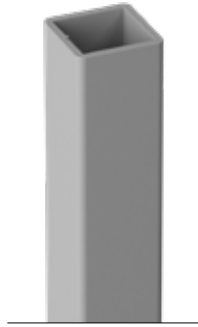

lxx = 311 x 10E3 mmE4  
lyy = 3.13 x 10E3 mmE4

### FINISHES



## 65 x 16.5mm baluster

**with centre web**

6100mm long

**Satin Black, Monument Matt,  
Pearl White Gloss or Mill finish**

Order Code: XP-6100-S65-B (Black)

XP-6100-S65-MN (Monument)

XP-6100-S65-W (White)

XP-6100-S65-M (Mill)

- 6100mm long slat/baluster  
Simply cut to required lengths
- Made from Alloy 6060 T6
- 1.2mm wall thickness baluster: 65x16.5mm profile
- Features centre web in extrusion profile for added strength

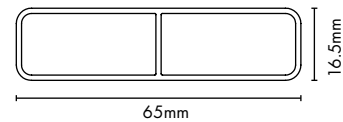

lxx = 9.60 x 10E3 mmE4  
lyy = 83.09 x 10E3 mmE4

### FINISHES



*Note: As an alternative for vertical slat, Alumawood Kwila & Western Red Cedar are available. Alumawood slats are 5800mm long. For post/framing use Monument or Black.*





# AIRE™

## 5800mm rectangular handrail

WITH CHANNEL INSERT

**Satin Black, Monument Matt,  
Pearl White Gloss or Mill finish**

Order Code: **A50-5800-RHR-B (Black)**

**A50-5800-RHR-MN (Monument)**

**A50-5800-RHR-W (White)**

**A50-5800-RHR-M (Mill)**

- 5800mm long 75x30mm rectangular profile
- Made from Alloy 6063 T6
- 2 part railing: (1) undercapping rail is screwed to top of post & (2) rectangular handrail is then snapped onto undercapping rail
- Easy to install

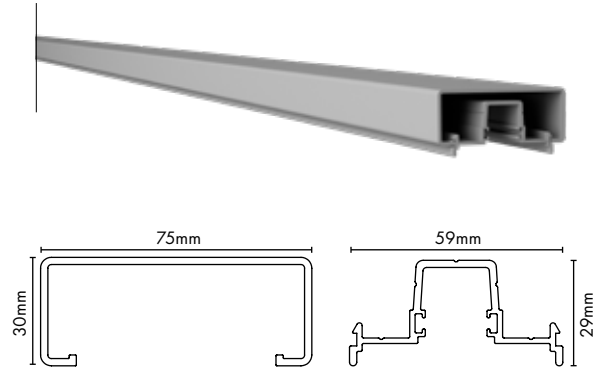
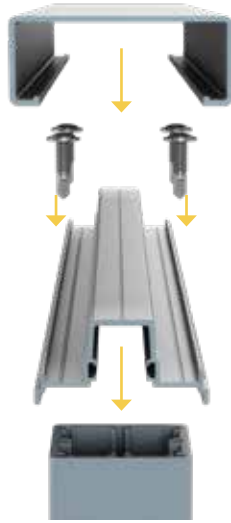

### FINISHES



## Oval handrail

WITH CHANNEL INSERT

**Satin Black, Monument Matt,  
Pearl White Gloss or Mill finish**

Order Code: **A50-5800-OHR-B (Black)**

**A50-5800-OHR-MN (Monument)**

**A50-5800-OHR-W (White)**

**A50-5800-OHR-M (Mill)**

- 5800mm long 75x30mm oval profile
- Made from Alloy 6063 T6
- 2 part railing: (1) undercapping rail is screwed to top of post & (2) oval handrail is then snapped onto undercapping rail
- Easy to install

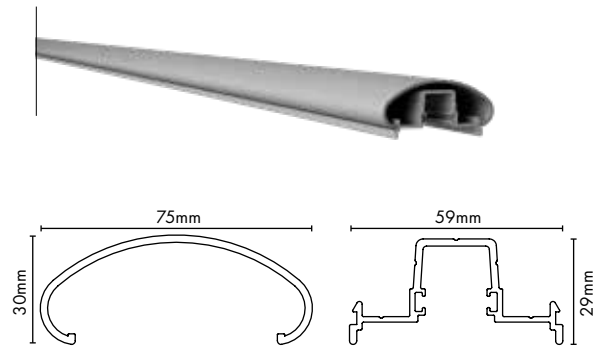
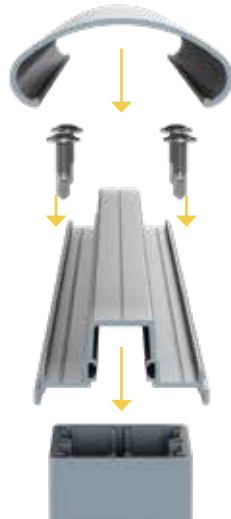

### FINISHES





# AIRE™

## 5800mm long bottom rail

45x45x3 mm

\*Picket/baluster inserts sold separately

**Satin Black, Monument Matt,  
Pearl White Gloss or Mill finish**

Order Code: **AR-5800-BR-B (Black)**  
**AR-5800-BR-MN (Monument)**  
**AR-5800-BR-W (White)**  
**AR-5800-BR-M (Mill)**

- 5800mm long heavy duty bottom rail
- Cut to required widths to fit between posts
- 6060 T6
- 3mm wall thickness for maximum strength
- Snap in insert into open cavity to suit either 16.5x16.5 or 65x16.5mm balusters
- Patented NON WELD friction fit system
- No rattle with tension legs gripping vertical balusters
- Fix off bottom rail to posts using mounting plates (refer P76)

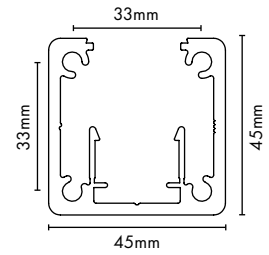

lxx = 136.78 x 10E3 mmE4  
lyy = 171.77 x 10E3 mmE4

### FINISHES



## 3250mm long Bottom rail insert

Suits 16.5x16.5mm balusters

**Satin Black, Monument Matt,  
Pearl White Gloss or Mill finish**

Order Code: **AR-3250-INS-16-B (Black)**  
**AR-3250-INS-16-MN (Monument)**  
**AR-3250-INS-16-W (White)**  
**AR-3250-INS-16-M (Mill)**

- Suits 16.5x16.5mm square balusters
- 3250mm long punched insert
- Cut to required widths
- 6063 T5
- Snaps into bottom rail (code: AR-5800-BR) to create the complete bottom rail system
- Punched at 92.5mm gap spacing providing 110mm centre to centre of baluster
- Balusters simply press down into punched holes and are held firmly in place via patented aluminium friction legs
- No rattle or movement of balusters

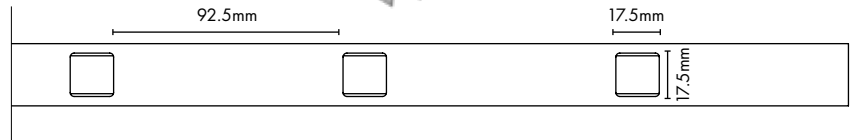
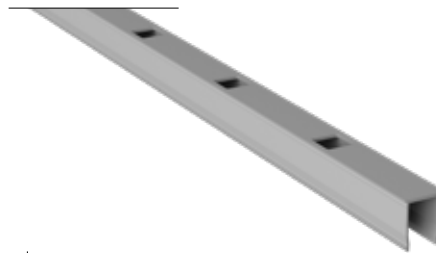

### FINISHES



## 3214mm long \*raked\* Bottom rail insert

Suits 16.5x16.5mm balusters and 34-37degree angle installation

**Satin Black, Monument Matt,  
Pearl White Gloss or Mill finish**

Order Code: **AR-3214-INS-16RA-B (Black)**  
**AR-3214-INS-16RA-MN (Monument)**  
**AR-3214-INS-16RA-W (White)**  
**AR-3214-INS-16RA-M (Mill)**

- 3214mm long punched insert
- Cut to required widths
- 6063 T5
- Snaps into bottom rail (code: AR-5800-BR) to create the complete bottom rail system
- Punched at 114mm gap spacing providing 137 centre to centre of baluster
- Suits 16.5x16.5mm square balusters for RAKED INSTALLATIONS - suits from 34 to 37 degrees
- Ideal solution for staircase installations

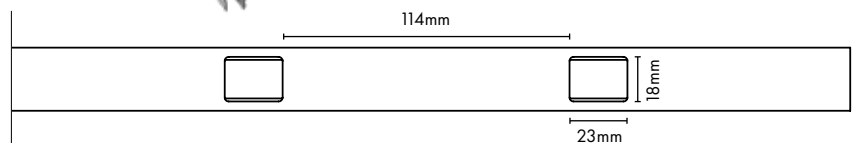
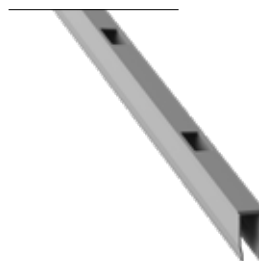

### FINISHES





# AIRE™

## 3022mm long Bottom rail insert

Suits 65x16.5mm vertical slat, 64mm gap spacing

**Satin Black, Monument Matt,  
Pearl White Gloss or Mill finish**

Order Code: **AR-3022-INS-65-B (Black)**  
**AR-3022-INS-65-MN (Monument)**  
**AR-3022-INS-65-W (White)**  
**AR-3022-INS-65-M (Mill)**

- 3022mm long punched insert; Cut to required widths
- 6063 T5
- Snaps into bottom rail (code: AR-5800-BR) to create the complete bottom rail system
- Punched at 64mm gap spacing providing 130mm centre to centre of baluster
- Suits 65x16.5mm slat balusters
- Balusters simply press down into punched holes/ bottom rail and are held firmly in place via patented aluminium friction legs
- No rattle or movement of balusters

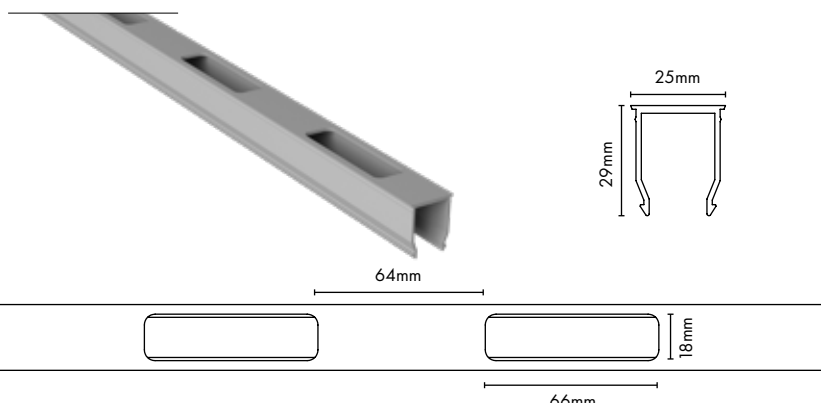

### FINISHES



## 3175mm long \*raked\* Bottom rail insert

Suits 65x16.5mm slat and 34-37degree angle installation

**Satin Black, Monument Matt,  
Pearl White Gloss or Mill finish**

Order Code: **AR-3175-INS-65RA-B (Black)**  
**AR-3175-INS-65RA-MN (Monument)**  
**AR-3175-INS-65RA-W (White)**  
**AR-3175-INS-65RA-M (Mill)**

- 3175mm long punched insert
- Cut to required widths
- 6063 T5
- Snaps into bottom rail (code: AR-5800-BR) to create the complete bottom rail system
- Punched at 81mm gap spacing providing 165 centre to centre of baluster
- Suits 65x16.5mm slat balusters for RAKED INSTALLATIONS - suits from 34 to 37 degrees
- Balusters simply press down into punched holes and are held firmly in place via patented aluminium friction legs
- Ideal solution for staircase installations

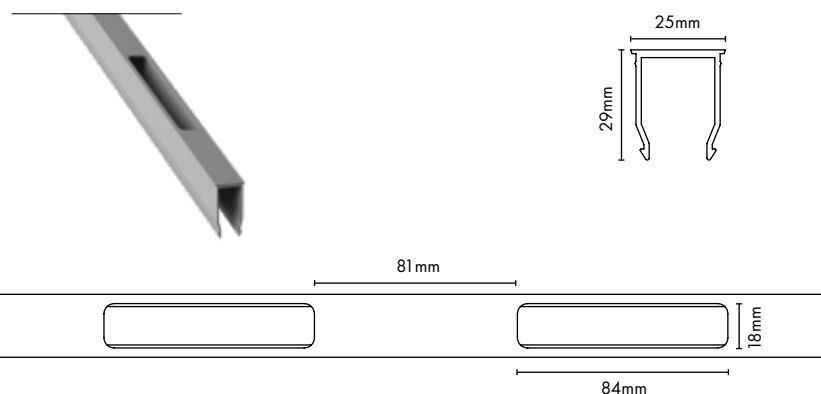

### FINISHES

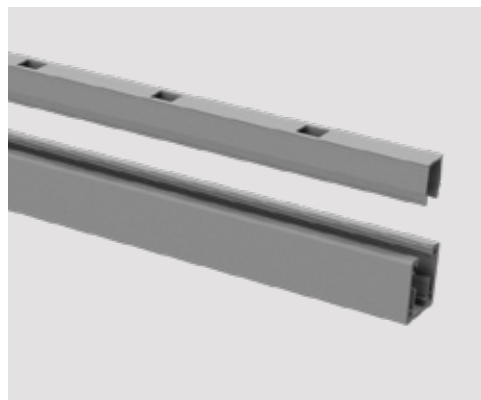

STEP 1

Select punched insert to snap into bottom rail.



STEP 2

Snap together. Tap insert into place with rubber mallet if required.



STEP 3

Completed bottom rail (also can be used as a midrail for 3 rail installation - simply insert).



# AIRE™

## 93mm wide top spacer

FOR 16.5x16.5MM PICKET BALUSTRADE  
PACK OF 20

**Satin Black, Monument Matt,  
Pearl White Gloss or Mill finish**

Order Code: **AR-SPACER-93MM-B (Black)**  
**AR-SPACER-93MM-MN (Monument)**  
**AR-SPACER-93MM-W (White)**  
**AR-SPACER-93MM-M (Mill)**

- Precision cut aluminium spacers snap into uncapping top rail (refer P71; Code: A50-5800-RHR/OHR)
- Accurately separates 16.5x16.5mm balusters in top rail
- Applies to inline/straight installations. Not applicable for raked installation
- Fast and easy to install and ensures accuracy of installation/spacing
- Sold in packs of 20

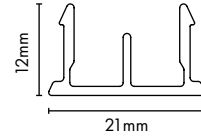
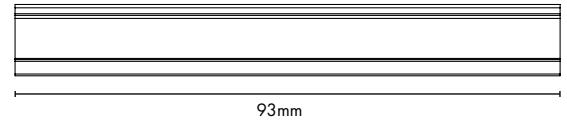
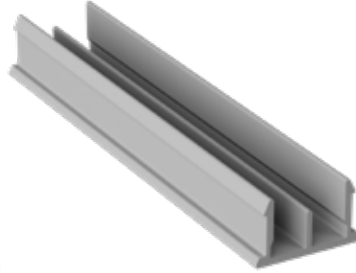

### FINISHES



## 65mm wide top spacer

FOR 65x16.5MM SLAT BALUSTRADE  
PACK OF 20

**Satin Black, Monument Matt,  
Pearl White Gloss or Mill finish**

Order Code: **AR-SPACER-65MM-B (Black)**  
**AR-SPACER-65MM-MN (Monument)**  
**AR-SPACER-65MM-W (White)**  
**AR-SPACER-65MM-M (Mill)**

- Precision cut aluminium spacers snap into uncapping top rail (refer P71; Code: A50-5800-RHR/OHR)
- Accurately separates 65x16.5mm slat balusters in top rail
- Applies to inline/straight installations. Not applicable for raked installation
- Fast and easy to install and ensures accuracy of installation/spacing
- Sold in packs of 20

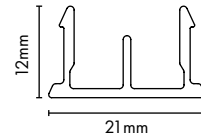
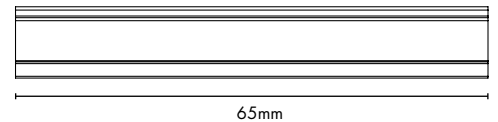
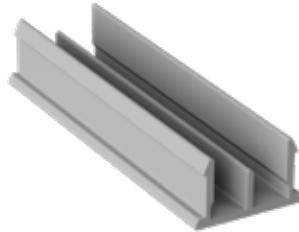

### FINISHES



## 1400mm long aluminium infill / spacer

**Satin Black, Monument Matt,  
Pearl White Gloss or Mill finish**

Order Code: **A50-1400-INF-B (Black)**  
**A50-1400-INF-MN (Monument)**  
**A50-1400-INF-W (White)**  
**A50-1400-INF-M (Mill)**

Used in 2 applications:

- (1) for RAKED stair installations, cut to required size as a spacer between balusters for snap into undercapping rail
- (2) for 3 rail installations, snap into undercapping rail to fill void as balusters do not penetrate into uncapping rail.  
TIP: infill is 1400mm wide so if opening size is wider than 1400mm, then 2 x infills will be required. Use a full length plus a shorter length or for a neater finish, cut each such that the join of infill is at midpoint of undercapping.

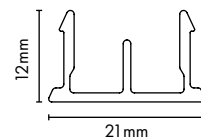
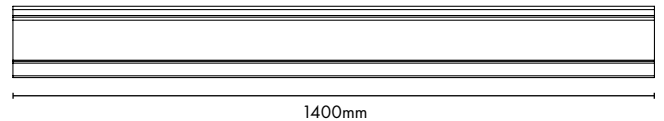
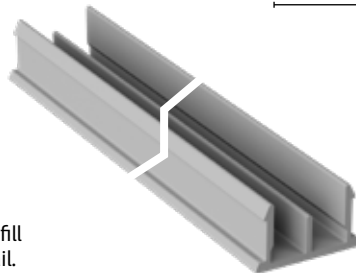

### FINISHES





# AIRE™



STEP 1

Screw fix first picket ensuring straight and in correct position.



STEP 2

Insert balance of pickets and snap in spacers. Do not screw fix remaining pickets yet. Ensure all pickets and spacing true and correct.



STEP 3

Screw fix each picket with spacers in position.





# AIRE™

## Mounting plate for bottom rail

45x73x4mm

PACK OF 2

**Satin Black, Monument Matt,  
Pearl White Gloss or Mill finish**

Order Code: AR-PLATE-B-2PK (Black)  
AR-PLATE-MN-2PK (Monument)  
AR-PLATE-W-2PK (White)  
AR-PLATE-M-2PK (Mill)

- 4mm thick aluminium plates affix to either end of bottom rail so that bottom rail can fix to posts
- 4 x countersunk holes enable screw fixing to bottom rail. Use 12gx50mm countersunk screws (code: CSK-12GX50-50PK)
- 2 x 7mm diameter holes for fixing plate to post
- Plates can be rotated for fixing off on the top side, bottom side or sideways
- For '3 rail' installation, mounting plates are used on the midrail in addition to bottom rail
- Sold as a pack of 2

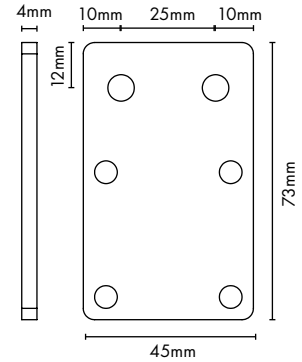
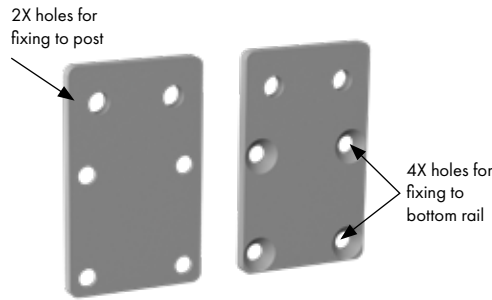

### FINISHES



## Mounting plate for bottom rail

**\* raked \***

PACK OF 2

Suits 34 to 37 degrees

**Satin Black, Monument Matt,  
Pearl White Gloss or Mill finish**

Order Code: AR-RK-PLATE-B-2PK (Black)  
AR-RK-PLATE-MN-2PK (Monument)  
AR-RK-PLATE-W-2PK (White)  
AR-RK-PLATE-M-2PK (Mill)

- 9mm thick aluminium plates affix to either end of bottom rail so that bottom rail can fix to posts
- Used for **RAKED** installations - plates suit 34 to 37 degree angles
- 4 x countersunk holes enable screw fixing to bottom rail. Use 12gx50mm countersunk screws (code: CSK-12GX50-50PK)
- 2 x elongated 7mm diameter fixing holes fix to post

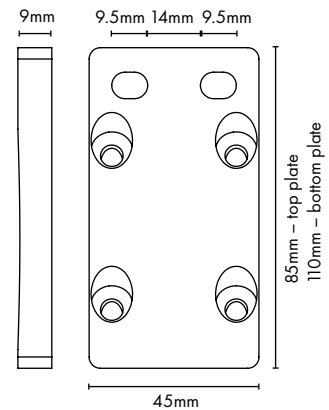
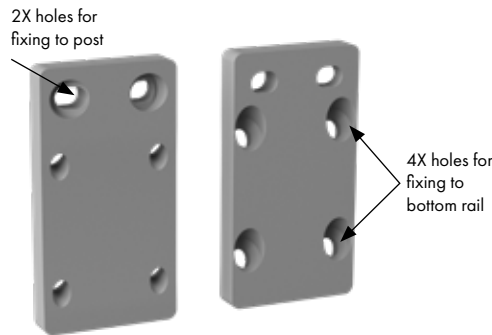

### FINISHES



- For '3 rail' installation, mounting plates are used on the midrail in addition to bottom rail
- Sold as a pack of 2
- 85mm long plate: higher side of bottom rail
- 110mm long plate: lower side of bottom rail



STEP 1

Screw fix mounting plate to bottom rail.



STEP 2

Plate can be rotated so fixing holes are on top, bottom or sides. Illustration shows fixing holes in top position.

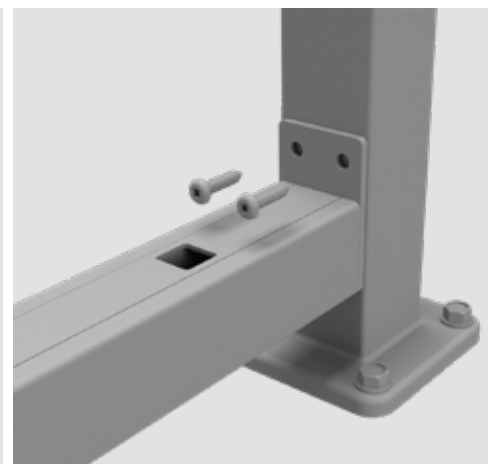

STEP 3

Screw fix mounting plate to post or other structure.



# AIRE™

## Rectangular end cap

### ALUMINIUM

Suits 75x30mm rectangular handrail

**Satin Black, Monument Matt,  
Pearl White Gloss or Mill finish**

Order Code: **A50-ECA-R-B (Black)**

**A50-ECA-R-MN (Monument)**

**A50-ECA-R-W (White)**

**A50-ECA-R-M (Mill)**

- End cap made from aluminium die cast
- Suits 75x30mm rectangular handrail
- Features protruding fins at bottom so end cap may be mechanically fixed to undercapping rail

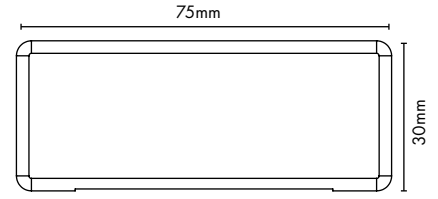
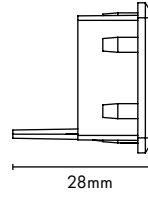

### FINISHES



## Offset bracket

### ALUMINIUM

2 PACK (1 LEFT & 1 RIGHT BRACKET)

Suits 75x30mm rectangular handrail

**Satin Black, Monument Matt,  
Pearl White Gloss or Mill finish**

Order Code: **A50-BRACKET-R-B-2PK (Black)**

**A50-BRACKET-R-MN-2PK (Monument)**

**A50-BRACKET-R-W-2PK (White)**

**A50-BRACKET-R-M-2PK (Mill)**

- Offset bracket made from aluminium die cast
- Suits 75x30mm rectangular handrail
- Caps over top of handrail and features offset leg for fixing to wall/post
- Mechanically fix bracket to handrail by screwing through side of bracket into handrail
- 2 x 7mm diameter holes for fixing to post/wall
- Sold as a 2 pack - 1 x left and 1 x right bracket

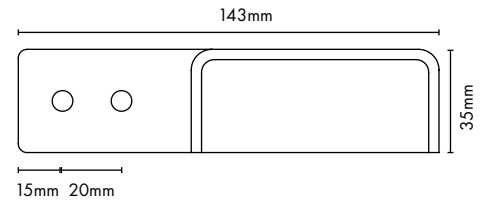
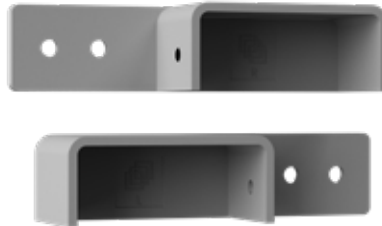

### FINISHES





# AIRE™

## Oval end cap

ALUMINIUM

Suits oval handrail

**Satin Black, Monument Matt,  
Pearl White Gloss or Mill finish**

Order Code: **A50-ECA-O-B (Black)**

**A50-ECA-O-MN (Monument)**

**A50-ECA-O-W (White)**

**A50-ECA-O-M (Mill)**

- End cap made from aluminium die cast
- Suits 75x30mm oval handrail
- Features protruding fins at bottom so end cap may be mechanically fixed to undercapping rail

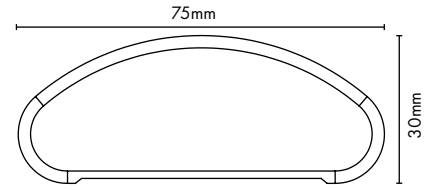
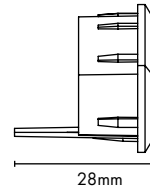

FINISHES



## Offset bracket

ALUMINIUM

2 PACK (1 LEFT & 1 RIGHT BRACKET)

Suits oval handrail

**Satin Black, Monument Matt,  
Pearl White Gloss or Mill finish**

Order Code: **A50-BRACKET-O-B-2PK (Black)**

**A50-BRACKET-O-MN-2PK (Monument)**

**A50-BRACKET-O-W-2PK (White)**

**A50-BRACKET-O-M-2PK (Mill)**

- Offset bracket made from aluminium die cast
- Suits 75x30mm oval handrail
- Caps over top of handrail and features offset leg for fixing to wall/post
- Mechanically fix bracket to handrail by screwing through side of bracket into handrail
- 2 x 7mm diameter fixing holes to post/wall
- Sold as a 2 pack - 1 x left and 1 x right bracket

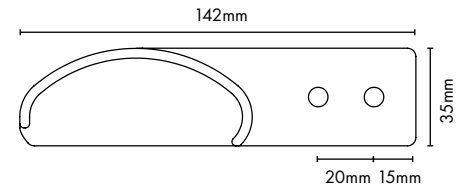

FINISHES

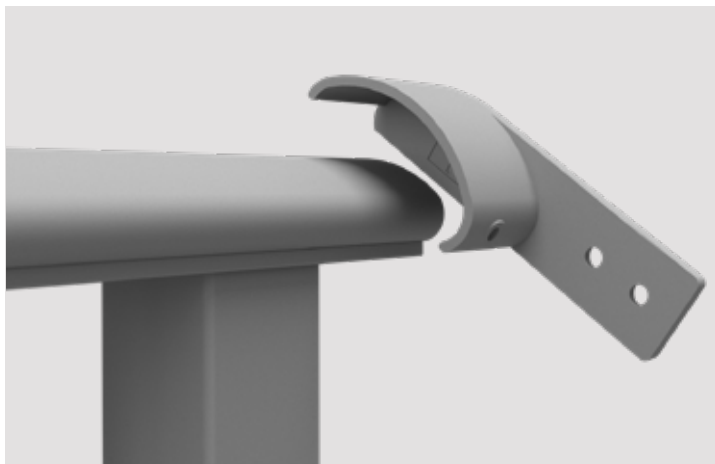

STEP 1

Offset bracket caps over installed handrail.

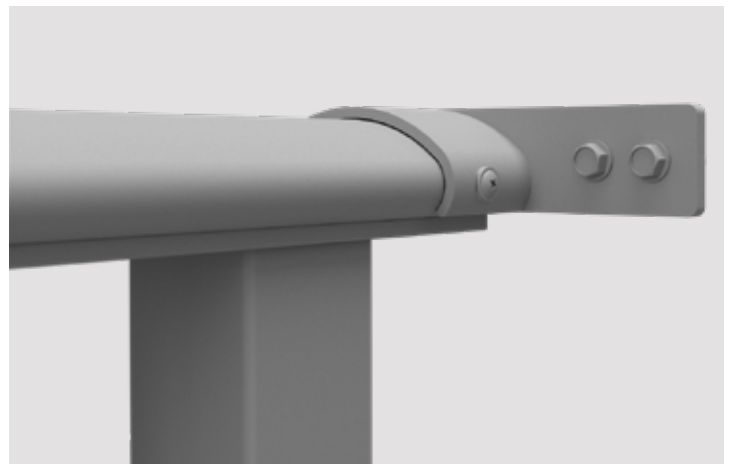

STEP 2

Screw fix offset bracket to (1) handrail and (2) post/wall.



# AIRE™

## Wall Plate

ALUMINIUM

Suits oval & rectangular handrail

**Satin Black, Monument, Pearl White or Mill finish**

Order Code: A50-WP-B (Black)

A50-WP-MN (Monument)

A50-WP-W (White)

A50-WP-M (Mill)

- Affixes internally to undercapping rail with only the bottom section visible – provides a slimline finish
- Affix to undercapping rail firstly and then affix to wall. Oval or rectangular handrail snaps over the undercapping rail with wall plate

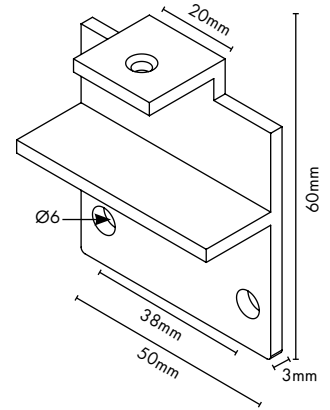

### FINISHES

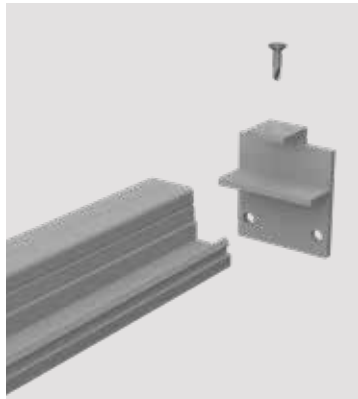

### STEP 1

Countersink the top hole of the wall plate. Insert wall plate onto undercapping rail and fix off through hole located on top of wall plate using a countersunk screw (not supplied).

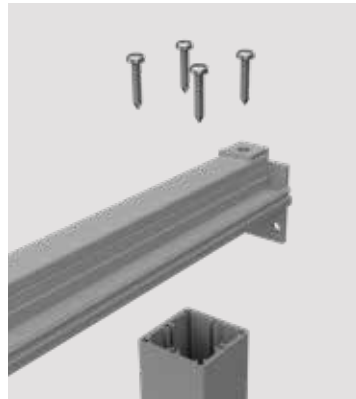

### STEP 2

Screw fix undercapping rail to post via 4 x screw flutes in corners of posts. Ensure wall plate neatly fits against wall/post. Use 12gx25mm panhead screw. (refer stock code AR-SCR-BR)

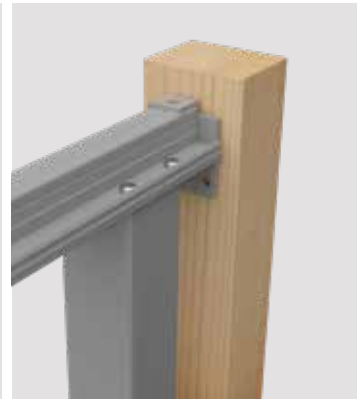

### STEP 3

Affix wall plate to wall/post using 2 x screws. Use suitable screws to fix having regard to structure.



### STEP 4

Clip on oval or rectangular handrail onto undercapping rail. Wall plate is hidden except for bottom section.

## Two part domical cover

POWDER COATED ALUMINIUM

**Black, Monument, White, Mill**

Order Code: XP-DC-2P-B (Black)

XP-DC-2P-M (Mill)

XP-DC-2P-MN (Monument)

XP-DC-2P-W (White)

- Suits 50x50mm post with 100x100mm base plate
- 106x106mm outer – 52x52mm inner – Alloy ADC12
- Cover can be fitted to posts after balustrade posts are installed

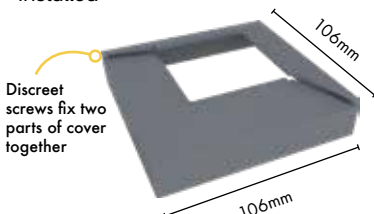

## Post dress rings

POWDER COATED ALUMINIUM

**Black, Monument, White, Mill**

Order Code: XP-DR-B (Black)

XP-DR-M (Mill)

XP-DR-MN (Monument)

XP-DR-W (White)

- Suits 50x50mm core drill posts
- 100mm x 100mm outer – 52mm x 52mm inner

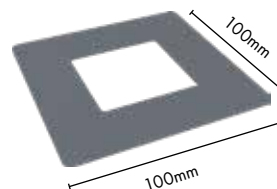



# AIRE™

## 12g x 25mm panhead screw with square drive head

SS304HC

PACK OF 50

**Black, White, Mill**

Order Code: AR-SCR-BR-50PK (Mill/Silver)

AR-SCR-BR-50PK-B (Black)

AR-SCR-BR-50PK-W (White)



- SS304 panhead screw 12gx25mm with square drive head
- Use for:

- (1) screwing bottom rail mounting plate to AIRE™ aluminium posts
  - (2) fixing sideways through the bottom rail into the baluster at 2 places per span to act as a 'locking' screw to mechanically fix bottom rail to balusters
  - (3) fixing of undercapping rail to top of post
- Screws are hidden by snap on rectangular or oval rail  
Use mill/silver finish screw

- For 3 rail installations, also use screws for fixing of midrail to AIRE™ posts, and as a 'locking' screw to affix midrail to baluster
- Sold as a pack of 50

*NOTE: for monument installations, use black screw or use mill/silver screw with monument touch up base paint.  
Lubricate screw before screwing.*

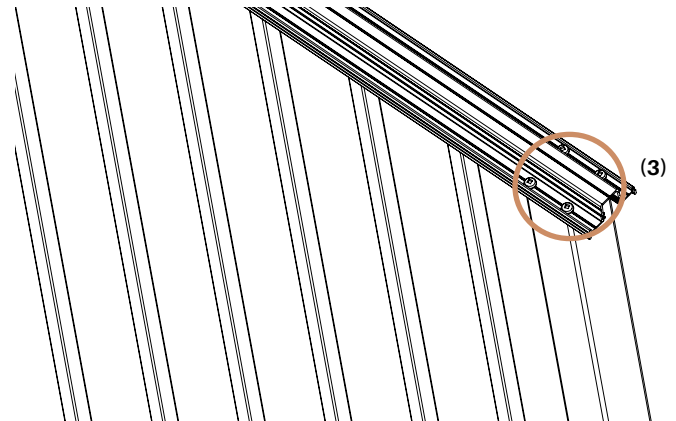
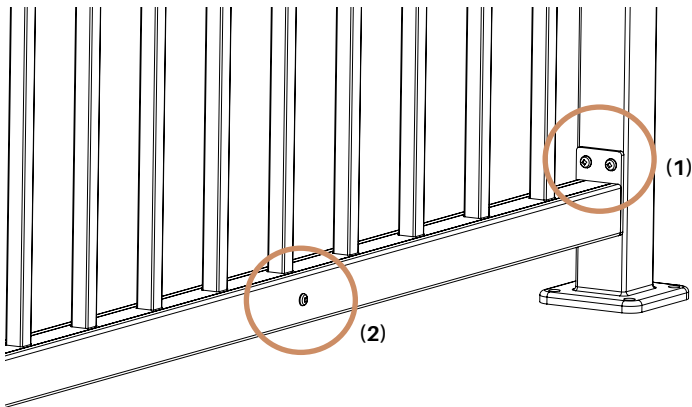

## Tek Screw – Stainless Steel 304

PACK OF 50

Order Code: SS-TS-50-SS304

- 12G x 20mm hex flange self drilling screw
- Stainless steel 304 grade
- Hex flange head enables fast and easy screwing/self drilling
- Use for fixing off each baluster to undercapping rail
- Sold as a pack of 50

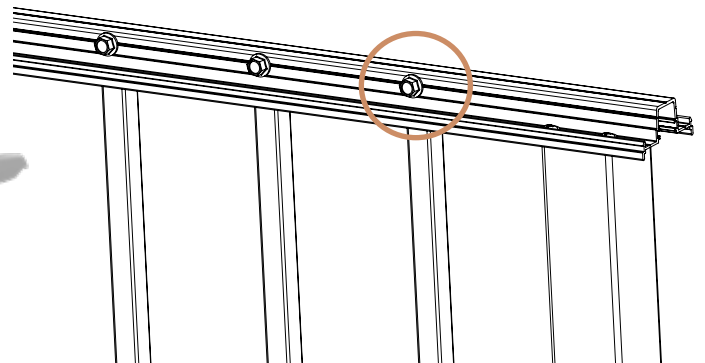





# AIRE™

## 12g x 50mm long countersunk screws

SS304

50 PACK

Order Code: **CSK-12GX50-50PK**

- SS304 countersunk head 12gx50mm screw
- Use for screwing mounting plates to bottom rail
- Lubricate screws before screwing with a Phillips #3 bit
- Sold as a pack of 50

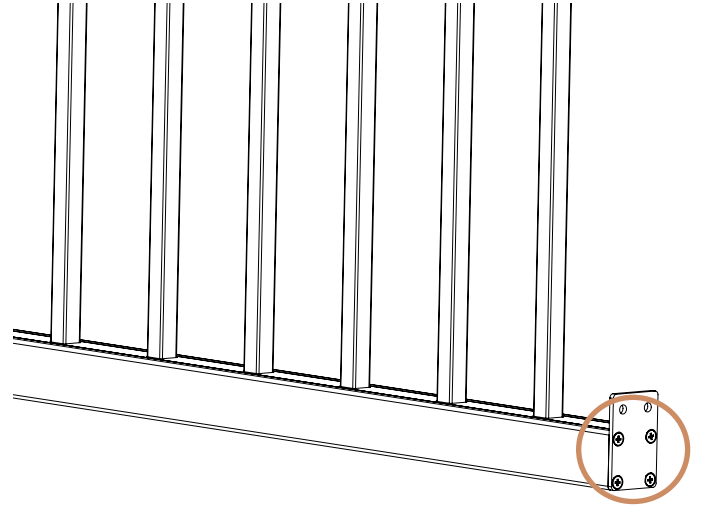

## 10g x 16mm self drilling wafer screws

BAG OF 100

**Black, Monument, White, Mill**

Order Code: **XP-SCREWS-B (Black)**

**XP-SCREWS-M (Mill)**

**XP-SCREWS-MN (Monument)**

**XP-SCREWS-W (White)**

- 10g x 16mm self drilling wafer head zinc plated screws
- Use for (1) screw fixing from underside of rectangular or oval end caps to uncapping rail or (2) sideways through offset rectangular or oval bracket into handrail
- Sold as a bag of 100

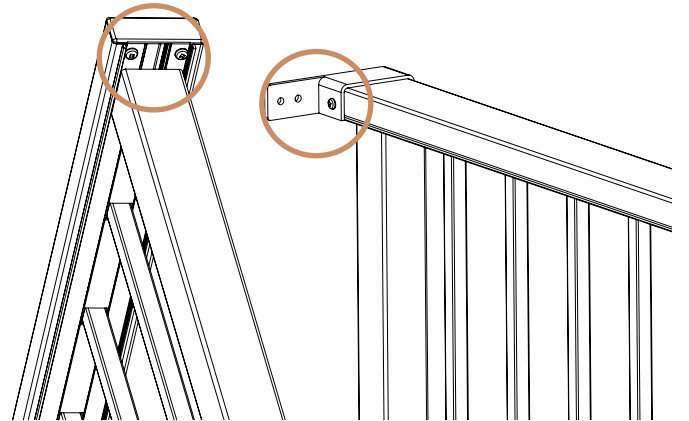

## Driver bit

Order Code: **DB-PH3**

- Driver bit to suit Phillips #3 screw head.
- Useful bit when screwing 12gx50mm countersunk screws for fixing of mounting plates to bottom rail. (refer screw code CSK-12GX050-50PK)



## Square head driver bit

Order Code: **DB-SQ3.4**

- Driver bit to suit 3.4mm square screw head hole
- Suits a variety of screws used in AIRE™ System (eg codes: AR-SCR-BR-50PK)



## Touch Up Paint

150g SPRAY CAN

**Black, Monument and Pearl White finish**

Order Code: **PAINT-B (Black)**

**PAINT-MN (Monument)**

**PAINT-W (White)**

- Colour match touch up paint





# FABRICATION OVERVIEW

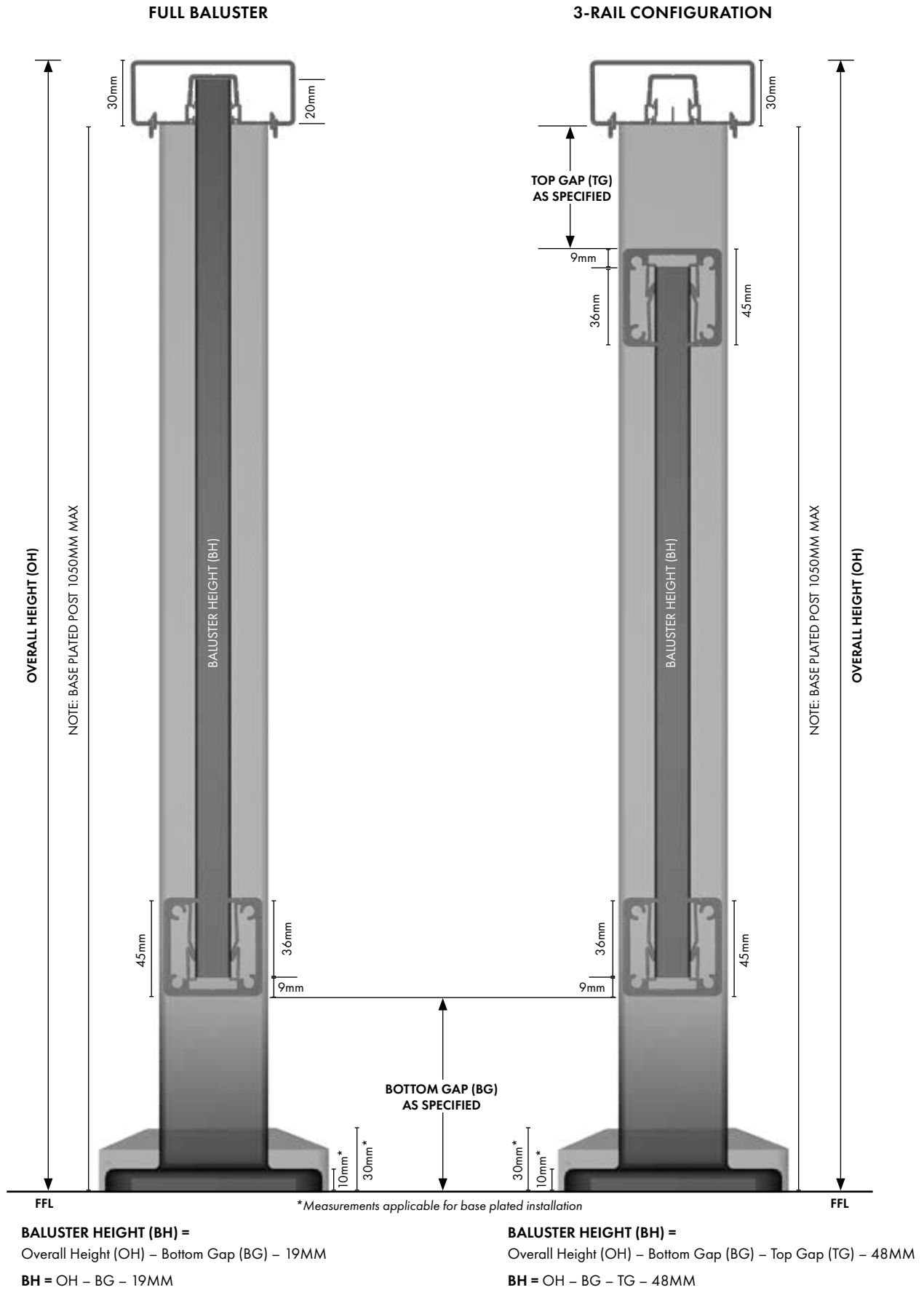



**NOTE – Select finish code:**  
(EG AR-1050-FPBP-B for black)



BLACK



MONUMENT



WHITE



MILL

Order Code	Description	Colours
AR-1050-FPBP-B/M/MN/W	1050mm high – 50x50mm post with welded on 100x100mm base plate	
AR-5800-FP-B/M/MN/W	5800mm long – 50x50mmx3.2mm full post	
AR-1500-FMID-B/M/MN/W	1500mm long – 50x50x4mm MID post with welded on 150x150 face mounting plate	
AR-1500-FMLR-B/M/MN/W-2PK	1500mm long – 50x50x4mm END posts with welded on 160x150 face mounting plates – LEFT & RIGHT	
A50-1400D-HALF-B/M/MN/W	1400mm long – 50x25x3mm half post	
A50-5800D-HALF-B/M/MN/W	5800mm long – 50x25x3mm half post	
A50-1400-INF-B/M/MN/W	1400mm long – 21x12mm infill	
AR-5600-PB-B/M/MN/W	5600mm long – 16.5 x 16.5 x 1.4mm baluster	
XP-6100-S65-B/M/MN/W	6100mm long – 65 x 16.5mm slot baluster	
AW-5800-S65-KWI/WRC	5800mm long – 65 x 16.5mm slot baluster – timber image finish	
A50-5800-RHR-B/M/MN/W	5800mm long rectangular handrail with undercapping rail	
A50-5800-OHR-B/M/MN/W	5800mm long oval handrail with undercapping rail	
AR-5800-BR-B/M/MN/W	5800mm long – Bottom rail	
AR-3250-INS-16-B/M/MN/W	3250mm long – Bottom rail insert for 16.5mm square pickets	
AR-3214-INS-16RA-B/M/MN/W	3214mm long – Raked bottom rail insert for 16.5mm square pickets	
AR-3022-INS-65-B/M/MN/W	3022mm long – Bottom rail insert for 65 x 16.5mm vertical slat	
AR-3175-INS-65RA-B/M/MN/W	3175mm long – Raked bottom rail insert for 65 x 16.5mm vertical slat	
AR-SPACER-93MM-B/M/MN/W	93mm wide top spacer for 16.5 x 16.5mm picket balustrade	
AR-SPACER-65MM-B/M/MN/W	65mm wide top spacer for 65 x 16.5mm vertical slat balustrade	
A50-1400-INF-B/M/MN/W	1400mm long aluminium infill/spacer	
AR-PLATE-B/M/MN/W-2PK	Mounting plate for bottom rail – 2 pack	
AR-RK-PLATE-B/M/MN/W-2PK	Mounting plate for bottom rail (Raked) – 2 pack	
A50-ECA-R-B/M/MN/W	75 x 30mm rectangular end cap	
A50-BRACKET-R-B/M/MN/W-2PK	143 x 35mm rectangular handrail offset bracket	
A50-ECA-O-B/M/MN/W	75 x 30mm oval end cap	
A50-BRACKET-O-B/M/MN/W-2PK	142 x 35mm oval handrail offset bracket	
A50-WP-B/M/MN/W	Wall plate (attaches to undercapping rail)	
XP-DC-2P-B/M/MN/W	106 x 106mm two part domical cover	
XP-DR-B/M/MN/W	100 x 100mm dress ring	
SS-TS-50-SS304	12g x 20mm picket/baluster screw with square drive head – 50 pack	
AR-SCR-BR-50PK/B/W	12g x 25mm panhead screw with square drive head – 50 pack	
XP-SCREWS-B/M/MN/W	Self drilling wafer screws – 100 pack	
CSK-12GX50-50PK	12g x 50mm long countersunk screws – 50 pack	
DB-PH3	Phillips #3 driver bit	
DB-SQ3.4	Square head driver bit	
PAINT-B/MN/W	Touch up paint	



# HORIZONTAL SLAT BALUSTRADE

## Why choose horizontal slat balustrade?

AIRE™ Horizontal Slat Balustrade is a complete non-weld system which perfectly typifies the saying 'simplicity is the ultimate form of sophistication'. With sleek lines and innovative design consideration ensuring screw fixings are hidden, the system is easy to install and yet provides for a stunning finish.

The system is stocked in 3 popular powder coat finishes – satin black, monument matt and pearl white glass. It is also available in mill finish allowing customisation of powder coat colour. Pre-powder coated material can be cut to required lengths and assembled onsite. The installation process is simple and effective – side frames are affixed to the sturdy aluminium posts and 65mm horizontal slats are screw fixed at 9mm spacings either side with a fixing cover hiding screws.

The system has been extensively load tested by accredited NATA testing facilities. Importantly, engineering compliance certification is available.

## Certification

Certificate of Compliance to load test requirements of AS/NZS 1170.0, AS/NZS 1170.1 and NCC2022. Contact us for engineering information.



# STYLES OF HORIZONTAL SLAT BALUSTRADE

---

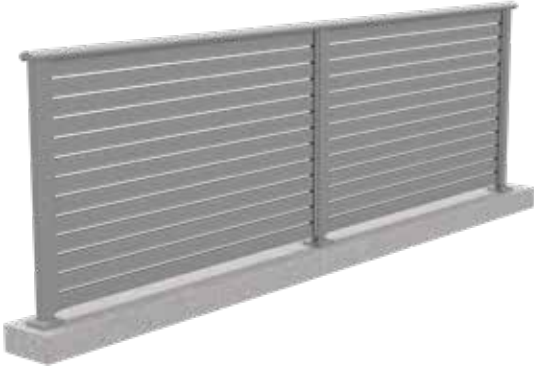

## 01 Horizontal Slat Balustrade

Horizontal 65mm slat balustrade with 9mm spacing with welded on base plated posts

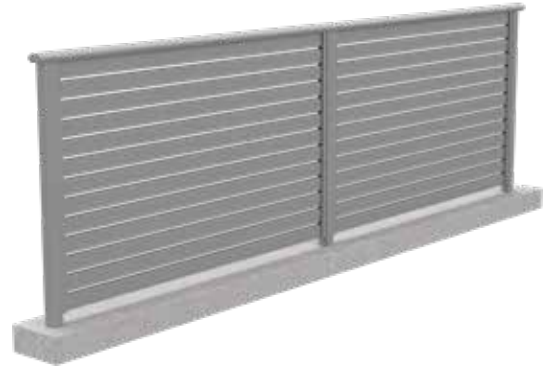

## 02 Horizontal Slat Balustrade

Horizontal 65mm slat balustrade with 9mm spacing with core drill posts

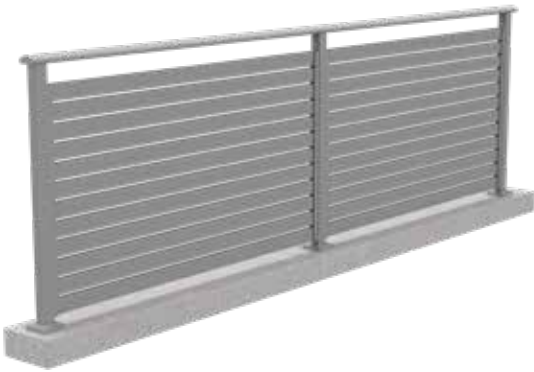

## 03 Horizontal Slat Balustrade

Horizontal 65mm slat balustrade with 9mm spacing with visibility gap and welded on base plated posts

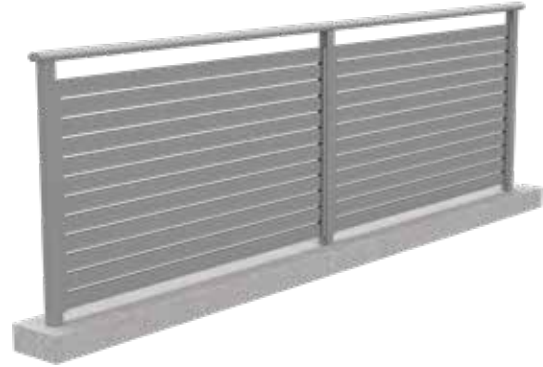

## 04 Horizontal Slat Balustrade

Horizontal 65mm slat balustrade with 9mm spacing with visibility gap and core drill posts

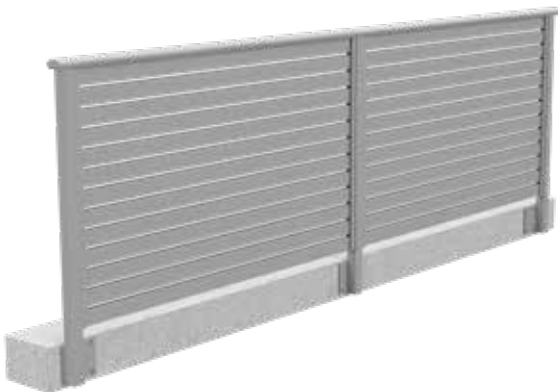

## 05 Horizontal Slat Face Mount

Horizontal 65mm slat balustrade with 9mm spacing and face mounted

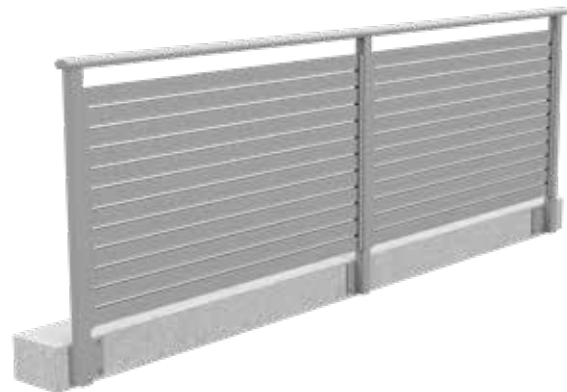

## 06 Horizontal Slat Face Mount

Horizontal 65mm slat balustrade with 9mm spacing with visibility gap and face mounted



# FINISHES

## Our colour range

AIRE™ horizontal slat balustrade is stocked in 3 popular balustrade powder coat finishes: Satin Black, Monument Matt and Pearl White Gloss. Mill finish is also available enabling customisation to any desired powder coat finish.

Satin black and monument matt continue to be the consistent colour palate for balustrade and seamlessly integrate into a variety of backgrounds. Pearl White is a growing trend in balustrade with the proliferation of Hamptons inspired design.

Genuine Interpon powder is used with Interpon D1000 manufacturer warranties provided.

AIRE™ horizontal slat balustrade extrusions are produced to the chemical composition, mechanical property and dimensional tolerances in AS-NZS 1866:1997



19%  
VISIBILITY WITH  
9MM SLAT  
SPACING



# HORIZONTAL SLAT BALUSTRADE

- 1 **75x30mm top rail**  
(available oval or rectangle profile)
- 2 **Undercapping rail**
- 3 **75x30mm end cap**  
(available to suit oval or rectangle profile)
- 4 **Snap in infill**  
(into undercapping void for neat finish)
- 5 **65x16.5mm horizontal slat balusters**
- 6 **25x26mm Side frame** (fixes to post)
- 7 **25x11 mm Fixing cover**
- 8 **10g x 16mm wafer SS304 screws**  
(various applications)
- 9 **12g x 25mm screws**  
(for fixing undercapping rail to posts)
- 10 **50x50 aluminium post**  
(core drill, welded base plate or face mount posts)
- 11 **2 part domical cover**  
(\*\* if using base plated posts;  
use a dress ring if core drill post)

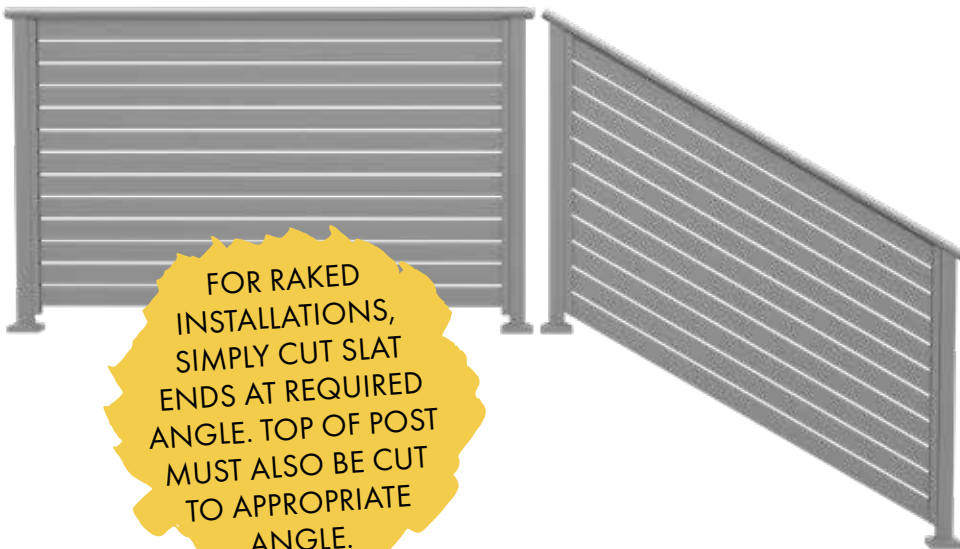
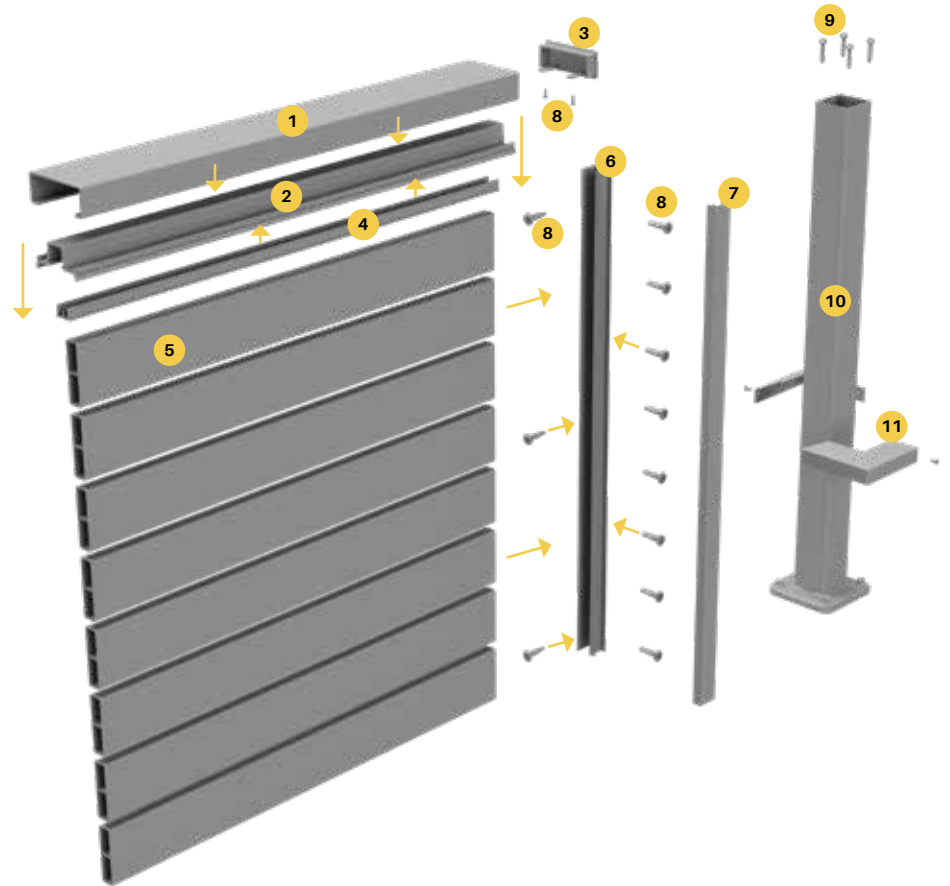

FOR RAKED  
INSTALLATIONS,  
SIMPLY CUT SLAT  
ENDS AT REQUIRED  
ANGLE. TOP OF POST  
MUST ALSO BE CUT  
TO APPROPRIATE  
ANGLE.



# HORIZONTAL SLAT BALUSTRADE

## Full post with base plate (welded)

1050mm H

**Satin Black, Monument Matt,  
Pearl White Gloss or Mill finish**

Order Code: AR-1050-FPBP-B (Black)

AR-1050-FPBP-MN (Monument)

AR-1050-FPBP-W (White)

AR-1050-FPBP-M (Mill)

- Sturdy base plated post at 1050mm high overall
- Simply cut top of post to reduce height if needed
- Made from Alloy 6106 T6: premium & rigid alloy
- 3.2mm wall thickness post: 50x50mm profile
- 100x100mm base plate 10mm thick welded on;
- 4 x 11mm diameter fixing holes
- Screw flutes in extrusion allow non-weld affixing of top rail

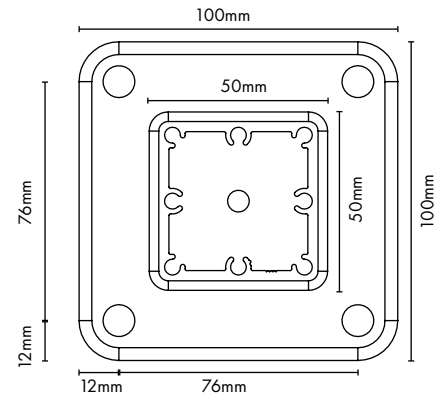
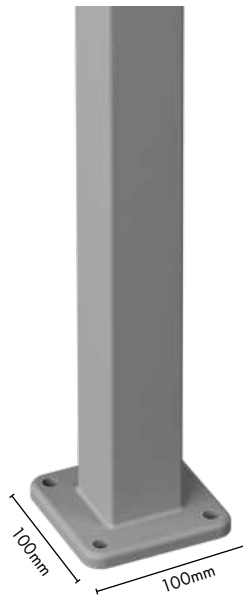

### FINISHES

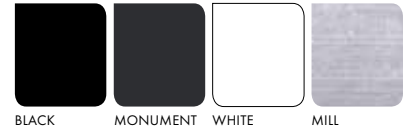

## 5800mm long – Full post

50x50x3.2mm

**Satin Black, Monument Matt,  
Pearl White Gloss or Mill finish**

Order Code: AR-5800-FP-B (Black)

AR-5800-FP-MN (Monument)

AR-5800-FP-W (White)

AR-5800-FP-M (Mill)

- 5800mm long post: suits core drill installation
- Cut to required lengths
- Made from Alloy 6106 T6: premium & rigid alloy
- 3.2mm wall thickness post: 50x50mm profile
- Screw flutes in extrusion allow non-weld affixing of top rail

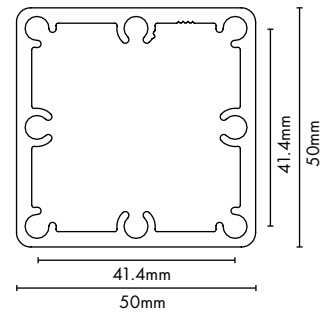

lxx = 214.10 x 10E3 mmE4  
lyy = 214.28 x 10E3 mmE4

### FINISHES



## Half post

50x25x3mm

**Satin Black, Monument Matt, White or Mill finish**

Order Code: A50-1400D-HALF-B (Black)

A50-1400D-HALF-MN (Monument)

A50-1400D-HALF-W (White)

A50-1400D-HALF-M (Mill)

A50-5800D-HALF-B (Black)

A50-5800D-HALF-MN (Monument)

A50-5800D-HALF-W (White)

A50-5800D-HALF-M (Mill)

- 50x25mm half post available 1400mm or 5800mm long – easily cut to required length
- 3mm rear wall thickness
- Use at start or end of spans with half post fixed to a wall or existing post
- Screw fix off sideways to structure via recessed post cavity. Infill snaps into cavity to hide fixings
- Handrail undercapping rail screw fixes into the 2 x screw flutes in half post
- Made from alloy 6106 T6

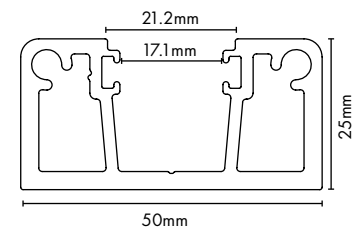

lxx = 32.82 x 10E3 mmE4  
lyy = 130.40 x 10E3 mmE4

### FINISHES







# HORIZONTAL SLAT BALUSTRADE

## Post infill

1400mm long

**Satin Black, Monument Matt,  
Pearl White Gloss or Mill finish**

Order Code: **A50-1400-INF-B (Black)**

**A50-1400-INF-MN (Monument)**

**A50-1400-INF-W (White)**

**A50-1400-INF-B (Mill)**

- Snap in infill mates with half post
- Easily cut infill to required post cavity length
- Infill covers half post screw fixings
- Made from alloy 6063 T6

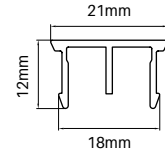

### FINISHES



BLACK



MONUMENT



WHITE



MILL



### STEP 1

Position half post against wall/post and screw fix. Pilot hole drilling required.



### STEP 2

Recommended minimum of 3 x fixings to structure.



### STEP 3

Snap infill into cavity to hide screw fixings.



### STEP 4

Half post installed - Handrail undercapping screw fixes into 2 x screw flutes in top of half post.





# HORIZONTAL SLAT BALUSTRADE

## Mid face mount post

1500mm H

**Satin Black, Monument Matt,  
Pearl White Gloss or Mill finish**

Order Code: **AR-1500-FMID-B (Black)**

**AR-1500-FMID-MN (Monument)**

**AR-1500-FMID-W (White)**

**AR-1500-FMID-M (Mill)**

- 1500mm long face mount MID post
- Heavy duty 50x50mm aluminium profile: 4mm wall post thickness
- 150x150mm welded on plate: 10mm thick
- Made from alloy 6106T6: premium & rigid alloy
- 4 x 13mm diameter fixing holes
- Easily cut down height of post to required length

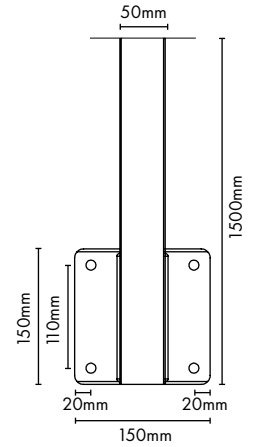

### FINISHES



STEP 1

Install anchors ensuring alignment to post plate holes



STEP 2

Fix off with dome nuts if using threaded rod or lag screw anchors

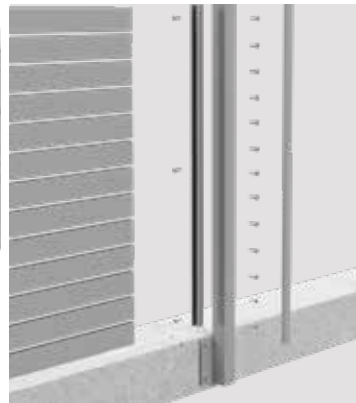

STEP 3

Install slats & brackets



STEP 4

Finished installation

## Face mount – 1 left & 1 right

1500mm H

**Satin Black, Monument Matt,  
Pearl White Gloss or Mill finish**

Order Code: **AR-1500-FMLR-B-2PK (Black)**

**AR-1500-FMLR-MN-2PK (Monument)**

**AR-1500-FMLR-W-2PK (White)**

**AR-1500-FMLR-M-2PK (Mill)**

- 1500mm long face mount END posts - LEFT & RIGHT
- Heavy duty 50x50mm aluminium profile: 4mm wall post thickness
- 160mmWx150Hmm welded on offset plates: 10mm thick
- Made from alloy 6106T6: premium & rigid alloy
- 4 x 13mm diameter fixing holes
- Easily cut down height of post to required length
- Offset plates enable posts to be positioned at absolute ends of face mount installations
- Screw flutes in post extrusion allows for non-weld affixing of handrail
- Sold as a 2 pack (left & right)

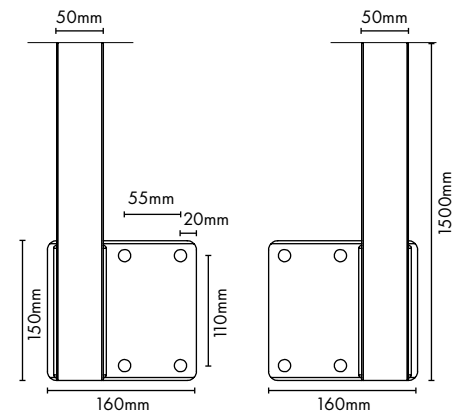
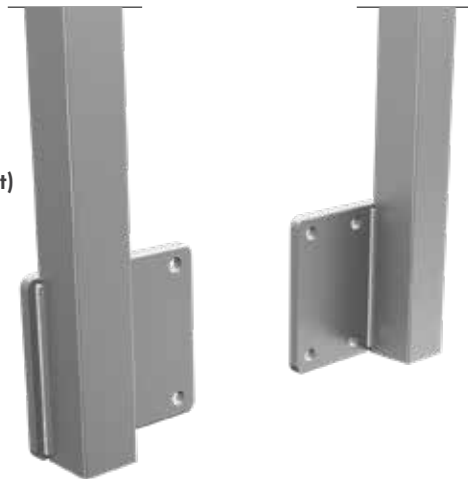

### FINISHES





# HORIZONTAL SLAT BALUSTRADE

## 65 x 16.5mm baluster with centre web

6100mm long

**Satin Black, Monument Matt,  
Pearl White Gloss or Mill finish**

Order Code: XP-6100-S65-B (Black)

XP-6100-S65-MN (Monument)

XP-6100-S65-W (White)

XP-6100-S65-M (Mill)

- 6100mm long slat/baluster
- Simply cut to required lengths
- Made from Alloy 6060 T6
- 1.2mm wall thickness baluster: 65x16.5mm profile
- Features centre web in extrusion profile for added strength

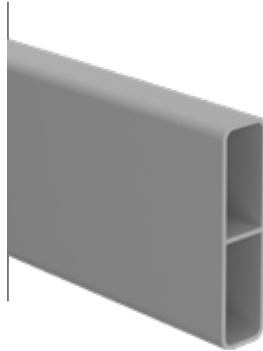

**CENTRE WEB  
ADDS STRENGTH &  
RIGIDITY TO SLAT**

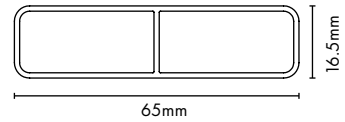

$l_{xx} = 9.60 \times 10E3 \text{ mmE4}$   
 $l_{yy} = 83.09 \times 10E3 \text{ mmE4}$

### FINISHES



BLACK

MONUMENT

WHITE

MILL

*Note: As an alternative for slat infill, Alumawood Kwila & Western Red Cedar are available. Alumawood slats are 5800mm long. For post/sideframe/handrail, use Monument or Black.*



KWILA

WRC

## Side frame

5800MM LONG

Order Code: QS-5800-SF-B (Black)

QS-5800-SF-MN (Monument)

QS-5800-SF-W (White)

QS-5800-SF-M (Mill)

- Alloy 6063-T6 / 5800mm long
- Slats fit neatly into side frame and are screw fixed
- Affix side frame directly to post
- Simply cut to required lengths
- Screw fixings are hidden when panel is assembled

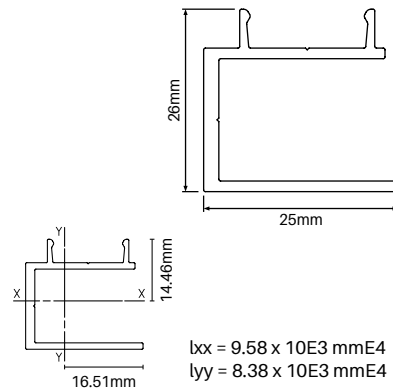

$l_{xx} = 9.58 \times 10E3 \text{ mmE4}$   
 $l_{yy} = 8.38 \times 10E3 \text{ mmE4}$

### FINISHES



BLACK

MONUMENT

WHITE

MILL



# HORIZONTAL SLAT BALUSTRADE

## Concealed fixing cover

5800MM LONG

Order Code: **QS-5800-CFC-B (Black)**  
**QS-5800-CFC-MN (Monument)**  
**QS-5800-CFC-W (White)**  
**QS-5800-CFC-M (Mill)**

- Alloy 6060-T5 / 5800mm long
- Snap-on cover for side frame
- Simply cut to required lengths
- Hides screws used to affix horizontal slats to side frame



MATES WITH QS-5800-SF

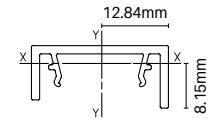
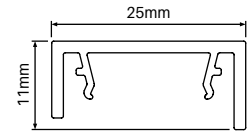

lxx = 0.71 x 10E3 mmE4  
 lyy = 6.58 x 10E3 mmE4

FINISHES



## 1400mm long aluminium infill / spacer

**Satin Black, Monument Matt, Pearl White Gloss or Mill finish**

Order Code: **A50-1400-INF-B (Black)**  
**A50-1400-INF-MN (Monument)**  
**A50-1400-INF-W (White)**  
**A50-1400-INF-M (Mill)**

- Snap into undercapping rail to fill void space in underside of undercapping rail
  - Simply cut to required lengths
- TIP: infill is 1400mm wide so if opening size is wider than 1400mm, then 2 x infills will be required. Use a full length plus a shorter length or for a neater finish, cut each such that the join of infill is at midpoint of undercapping.

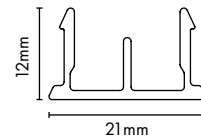
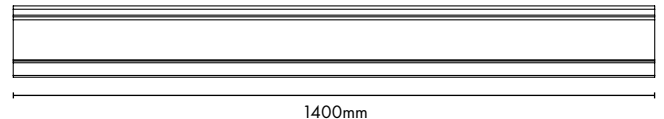
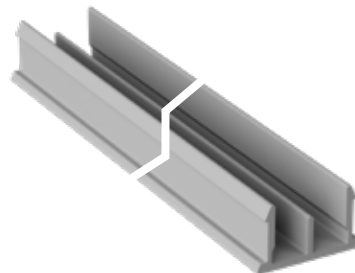

FINISHES





# HORIZONTAL SLAT BALUSTRADE

## 5800mm rectangular handrail

WITH CHANNEL INSERT

**Satin Black, Monument Matt,  
Pearl White Gloss or Mill finish**

Order Code: A50-5800-RHR-B (Black)  
A50-5800-RHR-MN (Monument)  
A50-5800-RHR-W (White)  
A50-5800-RHR-M (Mill)

- 5800mm long 75x30mm rectangular profile
- Made from Alloy 6063 T6
- 2 part railing: (1) undercapping rail is screwed to top of post & (2) rectangular handrail is then snapped onto undercapping rail
- Easy to install

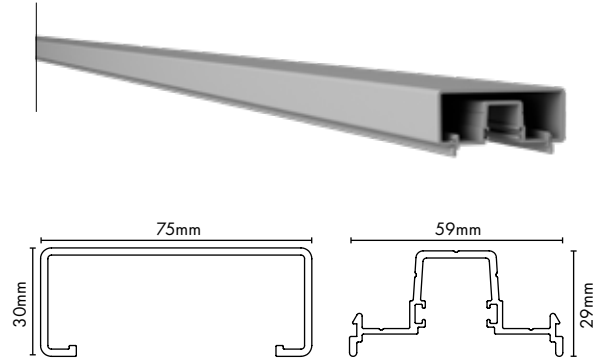
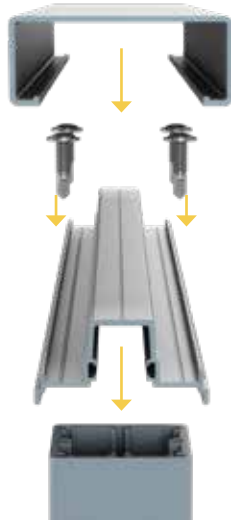

FINISHES



## Oval handrail

WITH CHANNEL INSERT

**Satin Black, Monument Matt,  
Pearl White Gloss or Mill finish**

Order Code: A50-5800-OHR-B (Black)  
A50-5800-OHR-MN (Monument)  
A50-5800-OHR-W (White)  
A50-5800-OHR-M (Mill)

- 5800mm long 75x30mm oval profile
- Made from Alloy 6063 T6
- 2 part railing: (1) undercapping rail is screwed to top of post & (2) oval handrail is then snapped onto undercapping rail
- Easy to install

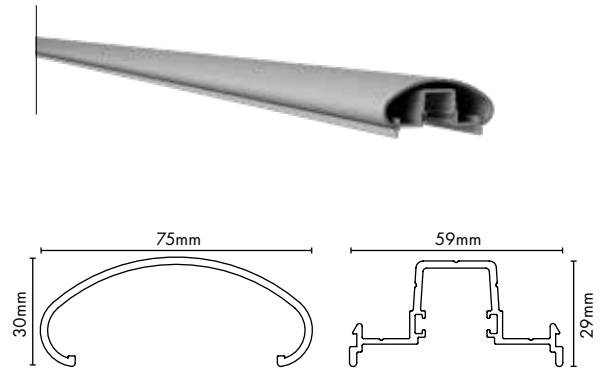
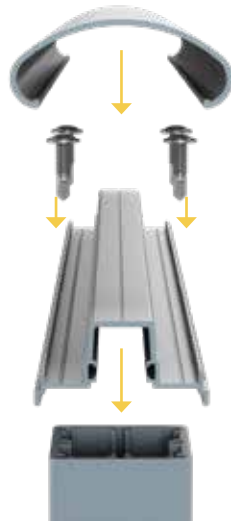

FINISHES





# HORIZONTAL SLAT BALUSTRADE

## Rectangular end cap

### ALUMINIUM

Suits 75x30mm rectangular handrail

**Satin Black, Monument Matt,  
Pearl White Gloss or Mill finish**

Order Code: **A50-ECA-R-B (Black)**

**A50-ECA-R-MN (Monument)**

**A50-ECA-R-W (White)**

**A50-ECA-R-M (Mill)**

- End cap made from aluminium die cast
- Suits 75x30mm rectangular handrail
- Features protruding fins at bottom so end cap may be mechanically fixed to undercapping rail

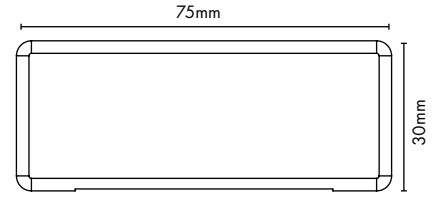
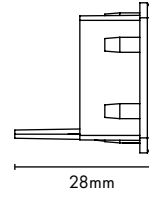

### FINISHES



## Offset bracket

### ALUMINIUM

2 PACK (1 LEFT & 1 RIGHT BRACKET)

Suits 75x30mm rectangular handrail

**Satin Black, Monument Matt,  
Pearl White Gloss or Mill finish**

Order Code: **A50-BRACKET-R-B-2PK (Black)**

**A50-BRACKET-R-MN-2PK (Monument)**

**A50-BRACKET-R-W-2PK (White)**

**A50-BRACKET-R-M-2PK (Mill)**

- Offset bracket made from aluminium die cast
- Suits 75x30mm rectangular handrail
- Caps over top of handrail and features offset leg for fixing to wall/post
- Mechanically fix bracket to handrail by screwing through side of bracket into handrail
- 2 x 7mm diameter holes for fixing to post/wall
- Sold as a 2 pack - 1 x left and 1 x right bracket

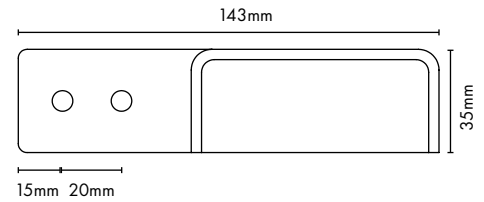
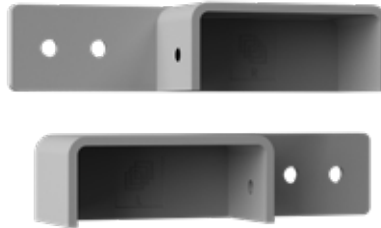

### FINISHES





# HORIZONTAL SLAT BALUSTRADE

## Oval end cap

ALUMINIUM

Suits oval handrail

**Satin Black, Monument Matt,  
Pearl White Gloss or Mill finish**

Order Code: **A50-ECA-O-B (Black)**

**A50-ECA-O-MN (Monument)**

**A50-ECA-O-W (White)**

**A50-ECA-O-M (Mill)**

- End cap made from aluminium die cast
- Suits 75x30mm oval handrail
- Features protruding fins at bottom so end cap may be mechanically fixed to undercapping rail

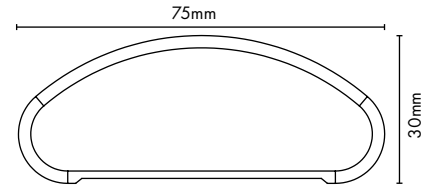
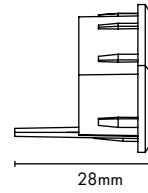

FINISHES



## Offset bracket

ALUMINIUM

2 PACK (1 LEFT & 1 RIGHT BRACKET)

Suits oval handrail

**Satin Black, Monument Matt,  
Pearl White Gloss or Mill finish**

Order Code: **A50-BRACKET-O-B-2PK (Black)**

**A50-BRACKET-O-MN-2PK (Monument)**

**A50-BRACKET-O-W-2PK (White)**

**A50-BRACKET-O-M-2PK (Mill)**

- Offset bracket made from aluminium die cast
- Suits 75x30mm oval handrail
- Caps over top of handrail and features offset leg for fixing to wall/post
- Mechanically fix bracket to handrail by screwing through side of bracket into handrail
- 2 x 7mm diameter fixing holes to post/wall
- Sold as a 2 pack - 1 x left and 1 x right bracket

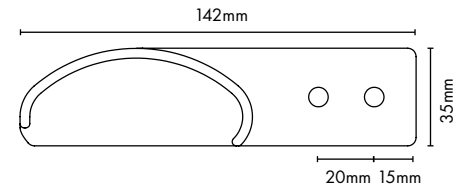
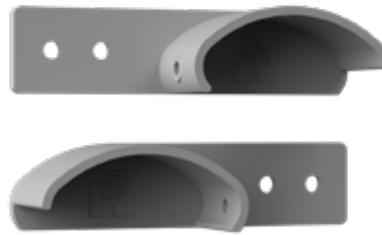

FINISHES

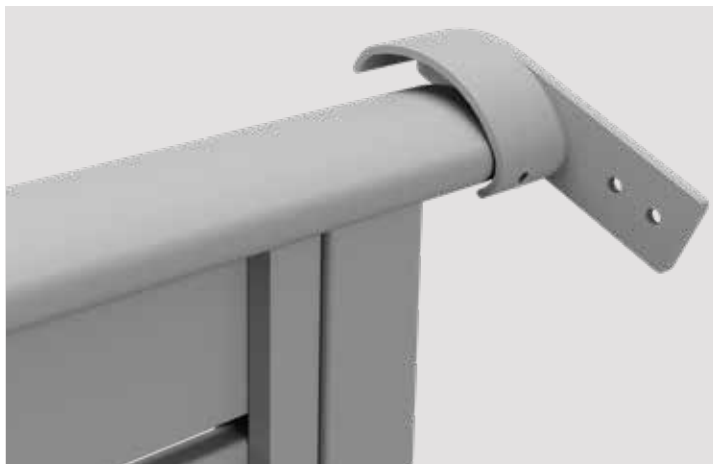

STEP 1

Offset bracket caps over installed handrail.

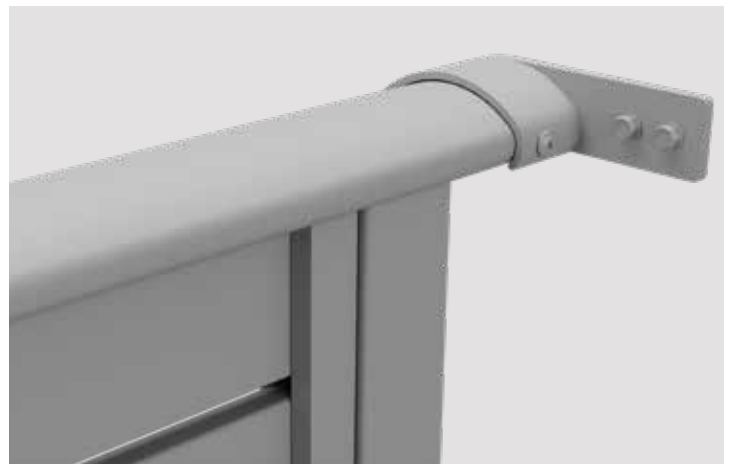

STEP 2

Screw fix offset bracket to (1) handrail and (2) post/wall.





# HORIZONTAL SLAT BALUSTRADE

## Wall Plate

ALUMINIUM

Suits oval & rectangular handrail

**Satin Black, Monument, Pearl White or Mill finish**

Order Code: A50-WP-B (Black)

A50-WP-MN (Monument)

A50-WP-W (White)

A50-WP-M (Mill)

- Affixes internally to undercapping rail with only the bottom section visible – provides a slimline finish
- Affix to undercapping rail firstly and then affix to wall. Oval or rectangular handrail snaps over the undercapping rail with wall plate

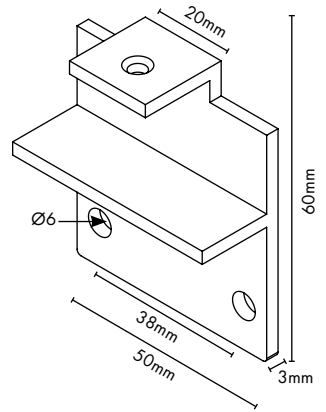

### FINISHES

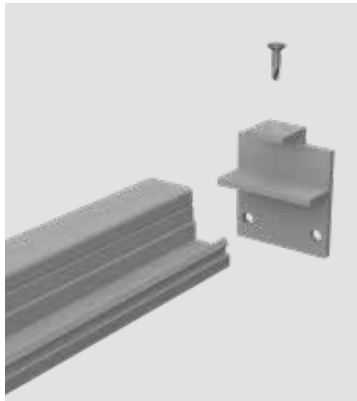

### STEP 1

Countersink the top hole of the wall plate. Insert wall plate onto undercapping rail and fix off through hole located on top of wall plate using a countersunk screw (not supplied).



### STEP 2

Screw fix undercapping rail to post via 4 x screw flutes in corners of posts. Ensure wall plate neatly fits against wall/post. Use 12x25mm panhead screw. (refer stock code AR-SCR-BR)



### STEP 3

Affix wall plate to wall/post using 2 x screws. Use suitable screws to fix having regard to structure.



### STEP 4

Clip on oval or rectangular handrail onto undercapping rail. Wall plate is hidden except for bottom section.





# HORIZONTAL SLAT BALUSTRADE

## Two part domical cover

POWDER COATED ALUMINIUM

**Black, Monument, White, Mill**

Order Code: XP-DC-2P-B (Black)

XP-DC-2P-M (Mill)

XP-DC-2P-MN (Monument)

XP-DC-2P-W (White)

- Suits 50x50mm post with 100x100mm base plate
- 106x106mm outer - 52x52mm inner - Alloy ADC12
- Cover can be fitted to posts after balustrade posts are installed

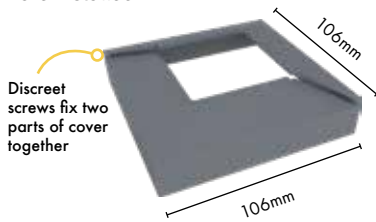

## Post dress rings

POWDER COATED ALUMINIUM

**Black, Monument, White, Mill**

Order Code: XP-DR-B (Black)

XP-DR-M (Mill)

XP-DR-MN (Monument)

XP-DR-W (White)

- Suits 50x50mm core drill posts
- 100mm x 100mm outer - 52mm x 52mm inner

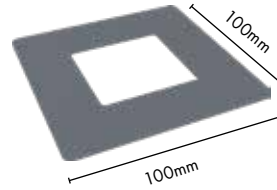

## Driver bit

Order Code: DB-PH3

- Driver bit to suit Phillips #3 screw head.



## Square head driver bit

Order Code: DB-SQ3.4

- Driver bit to suit 3.4mm square screw head hole
- Suits AR-SCR-BR-50PK screws



## Touch Up Paint

150g SPRAY CAN

**Black, Monument or White finish**

Order Code: PAINT-B (Black)

PAINT-MN (Monument)

PAINT-W (White)

- Colour match touch up paint



## Screw & spacer kit

SCREWS & SPACER BLOCKS

Order Code: QS-KIT

- 10 x spacer blocks providing 9mm gap spacing
- Spacer blocks assist accurate spacing of horizontal slats at 9mm
- Once a row of slat is screwed fixed in position, spacer block may be removed and reused for setting up next level
- Kit includes 50 x 10Gx18mm zinc screws: suggested not to use in installation. Instead, use stainless steel screws (refer screw fixing next page PP-SCREW)





# HORIZONTAL SLAT BALUSTRADE

## Self drilling wafer screws

10Gx16mm – BAG OF 50

### Satin Black or Monument heads

Order Code: PP-SCREW-B/MN-50PK

- Bags of 50 - 10G x 16mm self drilling wafer SS304 screw
- Powder coated heads for neat finish
- For installation in WHITE, screw fixings are hidden in below situations (1) and (2) so the stainless steel screws with black head can be used. For situation (3), source suitable white or silver headed 10Gx16mm screw (we can supply a suitable white headed zinc screw: refer stock code XP-SCREWS-W)
- Used for a variety of applications:

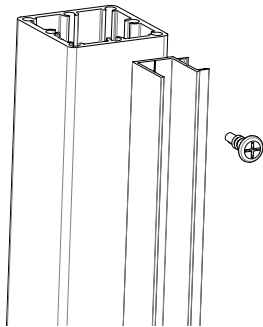

1) Fix side frame to AIRE™ aluminium post: fix off at top/middle/bottom

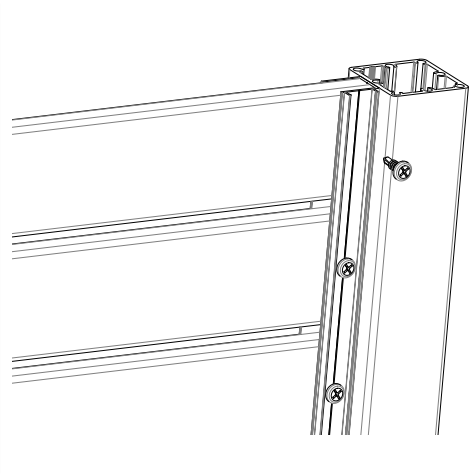

2) Fix off horizontal slats through side frame

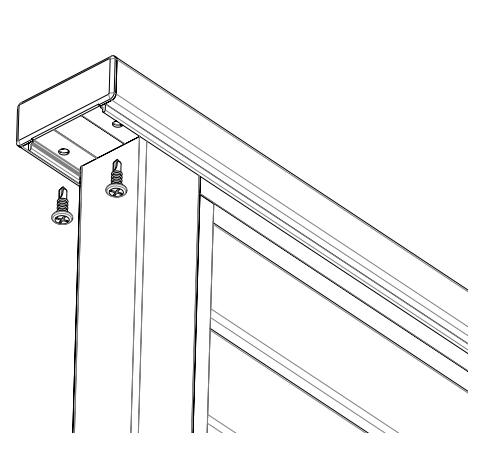

3) Fix end cap to undercapping rail  
(\*\* refer text above if installing a white balustrade)

## 12g x 25mm panhead screw with square drive head

SS304HC

PACK OF 50

### Mill

Order Code: AR-SCR-BR-50PK

- SS304 panhead screw 12gx25mm with square drive head
- Use for fixing of undercapping rail to top of post. Screws are hidden by snap on rectangular or oval rail.
- 4 x screws required per top of each post.

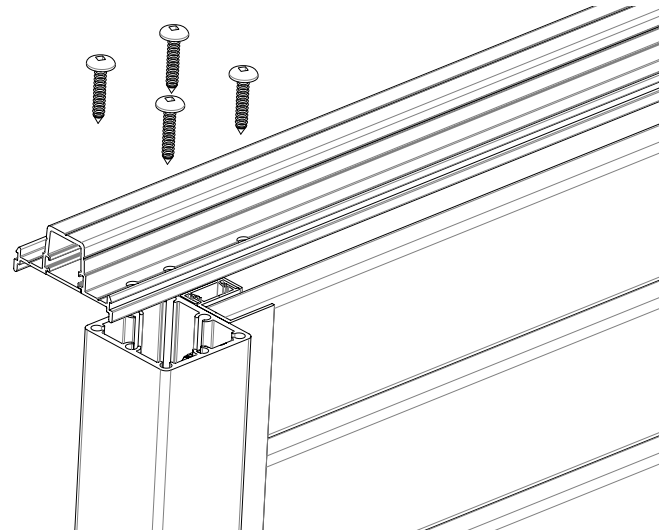

### M10 Timber fixing kit

4 PACK – SS316

Order Code: S-110LAG-4PK

- M10 x 110mm timber lag screws x4 with nuts and washers
- Hex drive head in screw



### M10 Concrete fixing kit

4 PACK – SS316

Order Code: S-120ROD-4PK

- M10 x 120mm concrete threaded rods x4 with nuts and washers
- Adhere into concrete with suitable chemical anchor



# HORIZONTAL SLAT BALUSTRADE INSTALL

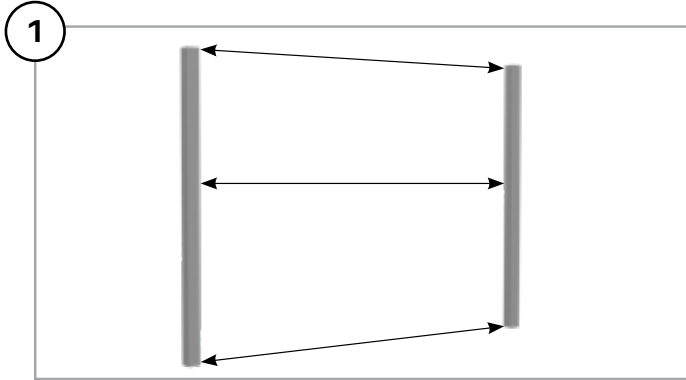

Take measurements between posts at 3 points: top, middle and bottom. Take note of smallest measurement.

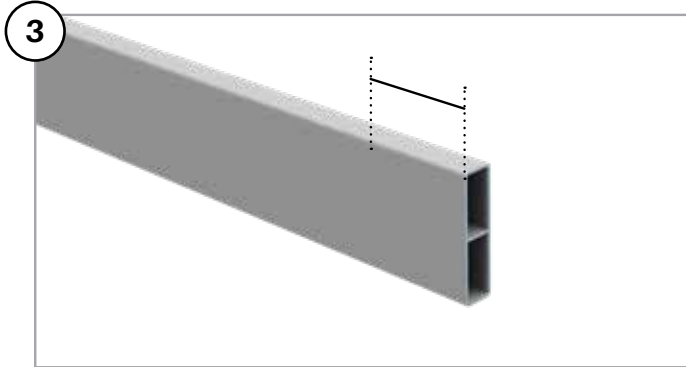

Cut aluminium slats 12mm less than total width of opening (refer to measurement in step 1). The 12mm deduction takes into account thickness of side frame on both sides of the screen and screw fixing head.



Screw off each slat as it is dropped in (ensuring each slat is level) If spacer blocks used, remove after each level is installed.

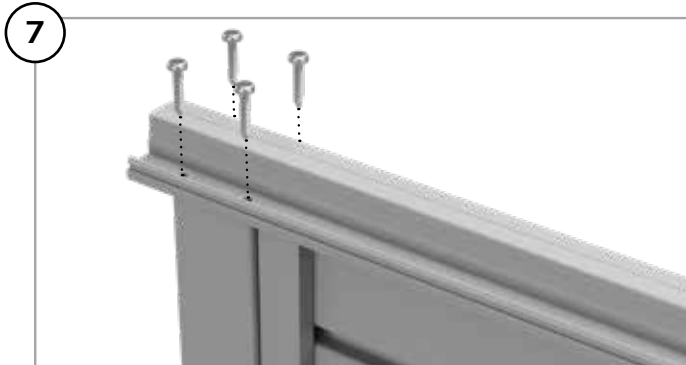

Cut uncapping rail to required length (having regard that capping rail may span across multiple posts). Drill and screw uncapping rail to post via screw flutes located in post. TIP: snap in aluminium infill into void on underside of uncapping rail before screwing fixing to posts

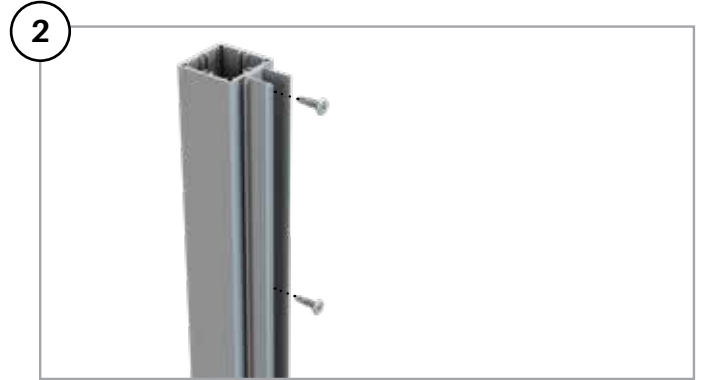

Cut side frames to desired height. Affix side frames to post with screws at top/middle/bottom.

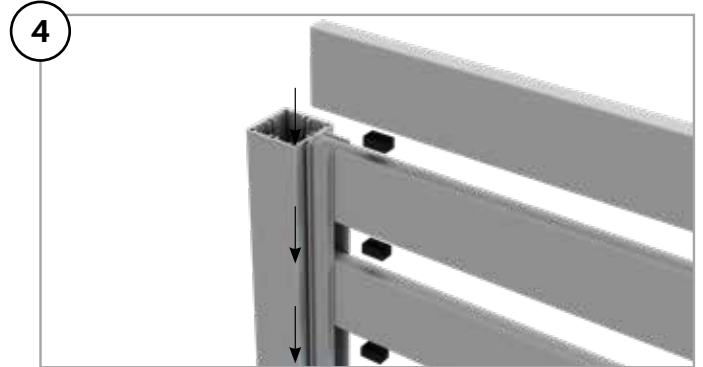

Drop in aluminium slats. TIP: Ensure bottom slat is level and screw off at both sides. Optional spacer blocks can be inserted to achieve a 9mm slat gap.

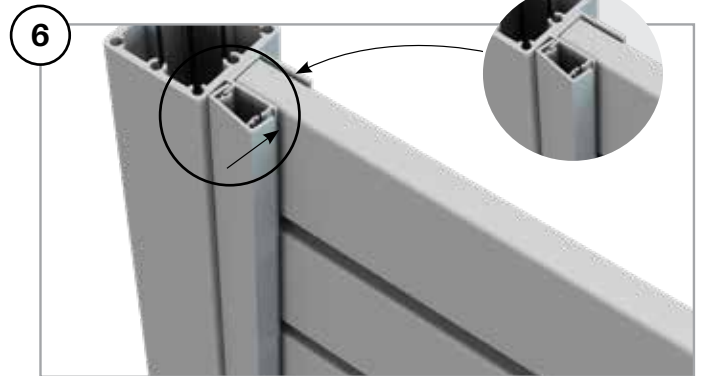

Cut fixing cover to appropriate height and snap onto side frame to hide screws. TIP: Use a padded timber block & mallet/hammer to gently tap on cover if needed, ensuring the longer leg is at the open side of the side frame.

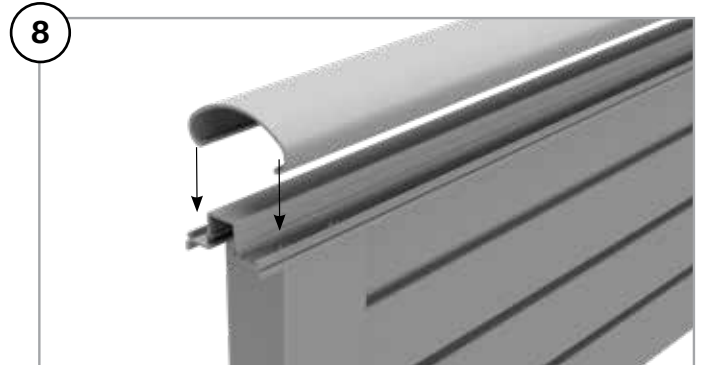

Cut handrail to required length (which may span across multiple posts) and snap onto uncapping rail. Finish ends with end cap or wall plate as required.



# FABRICATION OVERVIEW

## TYPICAL CONFIGURATION

- 13 x horizontal baluster  
65x16.5mm slats
- 9mm spacing between slats  
(including 9mm spacing  
above final slat to underside of  
undercapping rail)
- 88mm bottom gap from finish  
floor level (FFL) to first slat

## INSTALL TIP

Ensure the side frame concealing  
fixing cover faces towards inside  
of balcony.

## TYPICAL CONFIGURATION WITH VISIBILITY GAP

- 12 x horizontal baluster  
65x16.5mm slats
- 9mm spacing between slats  
(including 83mm spacing  
above final slat to underside of  
undercapping rail)
- 88mm bottom gap from finish  
floor level (FFL) to first slat

## INSTALL TIP

Ensure the side frame concealing  
fixing cover faces towards inside  
of balcony.

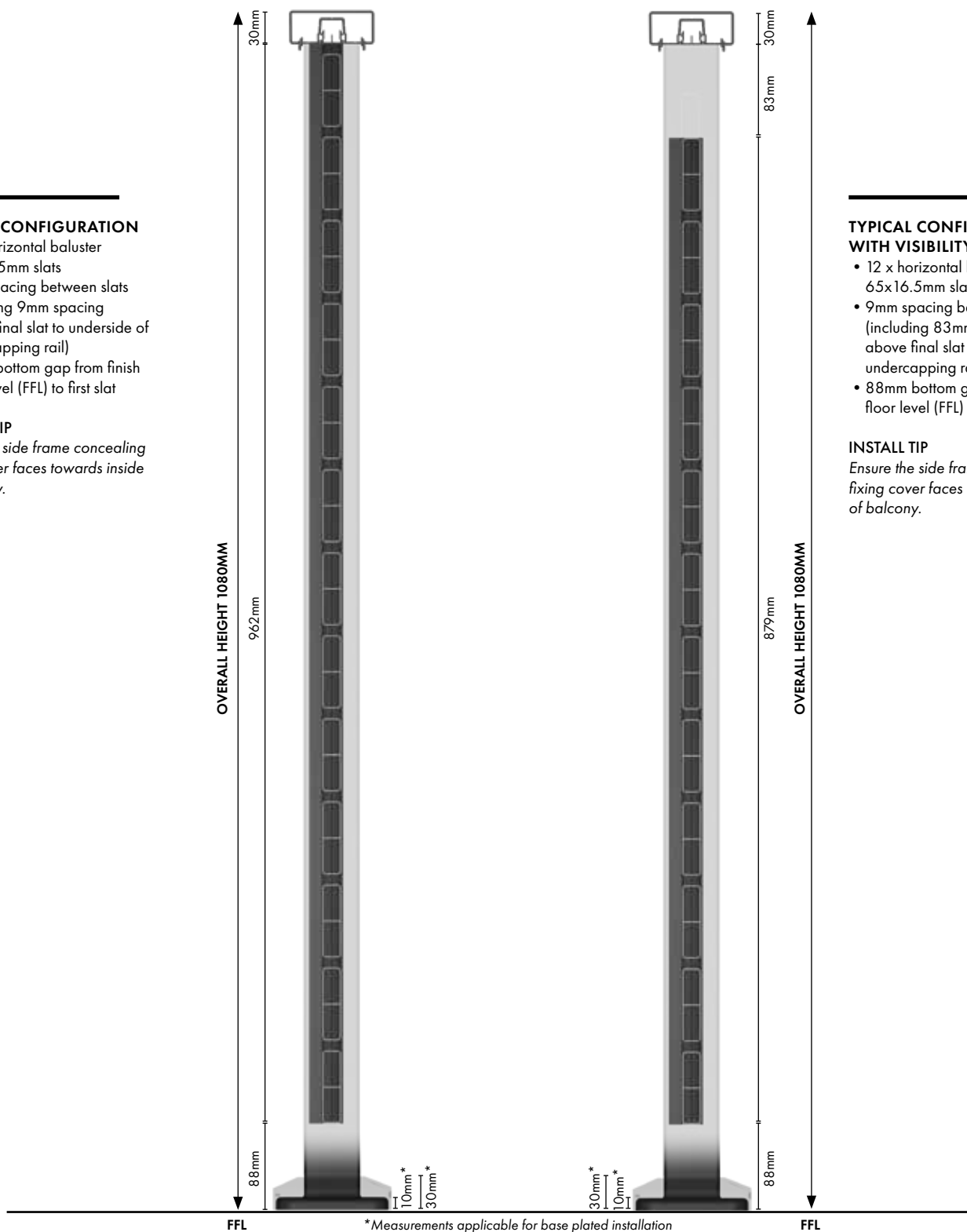

## IMPORTANT NOTES:

- We have tested horizontal slat balustrade with 9mm slat spacing with maximum 'daylight opening' span between posts of 1750mm. Engineering compliance certification reflects this configuration. Contact us for documentation. For different slat spacing or wider spans, independent engineering must be obtained.
- As the balustrade includes horizontal members/slats, ensure installation is compliant with relevant Australian Standards and National Construction Code (NCC) relating to potential climbing. For example, NCC clause 3.9.2.3 (e) contemplates horizontal members not to be used where there is a fall of 4 meters or greater (information valid as of August 2022: ensure any updates to Standards or NCC are adhered to).



**NOTE – Select finish code:**  
(EG AR-1050-FPBP-B for black)

# ORDER CODES

Order Code	Description	Colours
AR-1050-FPBP-B/M/MN/W	1050mm high – 50x50mm post with welded on 100x100mm base plate	
AR-5800-FP-B/M/MN/W	5800mm long – 50x50mmx3.2mm full post	
AR-1500-FMID-B/M/MN/W	1500mm long – 50x50x4mm MID post with welded on 150x150 face mounting plate	
AR-1500-FMLR-B/M/MN/W-2PK	1500mm long – 50x50x4mm END posts with welded on 160x150 face mounting plates – LEFT & RIGHT	
A50-1400D-HALF-B/M/MN/W	1400mm long – 50x25x3mm half post	
A50-5800D-HALF-B/M/MN/W	5800mm long – 50x25x3mm half post	
XP-6100-S65-B/M/MN/W	6100mm long – 65 x 16.5mm slat baluster (with centre web)	
AW-5800-S65-KWI/WRC	5800mm long – 65 x 16.5mm slat baluster (with centre web) – timber image finish	
QS-5800-SF-B/M/MN/W	5800mm long – 25x26mm Quickscreen side frame	
QS-5800-CFC-B/M/MN/W	5800mm long – 25x11mm Quickscreen concealed fixing cover	
A50-5800-RHR-B/M/MN/W	5800mm long rectangular handrail with undercapping rail	
A50-5800-OHR-B/M/MN/W	5800mm long oval handrail with undercapping rail	
A50-1400-INF-B/M/MN/W	1400mm long aluminium infill	
A50-ECA-R-B/M/MN/W	75 x 30mm rectangular end cap	
A50-BRACKET-R-B/M/MN/W-2PK	143 x 35mm rectangular handrail offset bracket	
A50-ECA-O-B/M/MN/W	75 x 30mm oval end cap	
A50-BRACKET-O-B/M/MN/W-2PK	142 x 35mm oval handrail offset bracket	
A50-WP-B/M/MN/W	Wall plate (attaches to undercapping rail)	
XP-DC-2P-B/M/MN/W	106 x 106mm two part domical cover	
XP-DR-B/M/MN/W	100 x 100mm dress ring	
PP-SCREW-B/MN	10g x 16mm SS304 self drilling wafer screw – 50 pack	
XP-SCREW-W	10g x 16mm zinc self drilling wafer screw – 100 pack	
AR-SCR-BR-50PK	12g x 25mm SS304 panhead screw with square drive head – 50 pack	
S-110LAG-4PK	M10 x 110mm SS316 long timber lag screw – 4 pack	
S-120ROD-4PK	M10 x 120mm thread rod with nuts/washers – 4 pack	
DB-PH3	Phillips #3 driver bit	
DB-SQ3.4	Square head driver bit	
PAINT-B/MN/W	Touch up paint	



BLACK



MONUMENT



WHITE



MILL



KWILA



WESTERN RED CEDAR



# PREMIUM PERF BALUSTRADE

## Why choose Premium Perf Balustrade?

PREMIUM PERF is a complete balustrade system featuring the growing trend for aluminium punched perforated infill panels.

As an alternative to glass, a number of key features make perforated aluminium an ideal selection including:

- ✔ shatterproof
- ✔ low maintenance
- ✔ extremely durable and corrosion resistant
- ✔ wind can pass through perforated holes
- ✔ being fully aluminium, application of the new Glass In Buildings Standard (AS1288-2021) is not relevant

Additionally, perf panels have excellent visibility resulting from the precision punching of 9mm diameter holes very close together.

The system is stocked in popular Akzo Nobel powder coat black and monument finish. With perforated aluminium, darker colours are easier to 'look through' providing superior visibility to the foreground.

The design and installation process has been carefully considered to ensure maximum visual appeal while ensuring ease of installation. Sturdy 50x50mm posts in core drill, base plate or face mount options with rectangular or oval handrails and a large range of accessories ensure a complete balustrade solution is available. Importantly, no welding is required and fully powder coated material is easy to assemble and install.

Extensive load testing by accredited NATA testing facilities coupled with engineering compliance confirm the integrity of the system.

**Premium Perf Balustrade is an innovative alternative to standard glass balustrade.**

## Certification

Certificate of Compliance to load test requirements of AS/NZS 1170.0, AS/NZS 1170.1 and NCC2022. Contact us for engineering information.

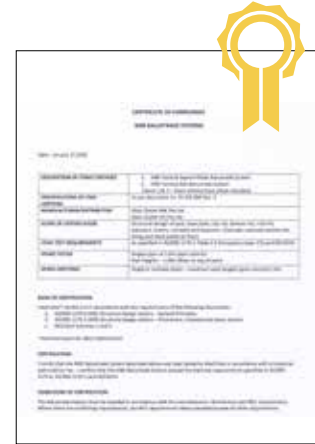



**aluminium outlet**  
A DIVISION OF GLASS OUTLET

**PERFORATED ALUMINIUM PANEL  
BALUSTRADE SYSTEM  
Estimating Tool (1.01)**

Colour: Black ▼

Handrail Type: Oval ▼

Item	Qty	Overall Length mm	Overall Height mm	Bottom Gap 124mm Max 25mm Min	Post Type	End 1 End type	End 2 End type	End Length		Body		
								Specify Min Length	L1=L2 mm	Length	No panels	Lb mm
A	1	10100	1080	50	Base Plate	End Cap	Bracket	300	495	9990	5	1800
B	10	8000	1100	70	Core Drill	End Cap	End Cap	200	245	5890	3	1800
C	3	6000	1000	-30	Base Plate	Bracket	Bracket	300	1145	5890	2	1800
D	4	18110	1080	50	Base Plate	End Cap	End Cap	400	0	18000	10	1800
E				50	Select	Select	Select		845	-110	-1	1800
F				50	Select	Select	Select		845	-110	-1	1800

**Warnings**

H>1080 Core drilled post only. Independent certification required.

G<25 If bottom gap less than 25mm trimming of panels will be required

**Notes**

- Height is measured from finished floor level to top of handrail. 1080mm Std Height recommended. 1000mm minimum. 1142mm maximum. If over 1080mm independent certification is required.
- Lengths are measured from centreline of posts
- See sketch on next page
- YouTube assembly video <https://youtu.be/sbFweG...>

**Certification**

Compliance to load test requirements of AS/NZS 1170.0, AS/NZS 1170.1 and NCC2022. Contact us for engineering information.



**FREE, EASY TO USE ESTIMATOR. EXCEL FORMAT. CONTACT US AND WE WILL EMAIL TO YOU!**

- ✔ Quickly & accurately cost jobs
- ✔ Instant specification of materials list
- ✔ Take the time & hassle out of quoting





# STYLES OF PREMIUM PERF BALUSTRADE

---

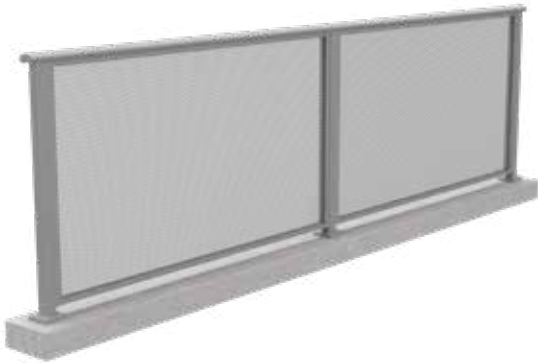

**01 Perf Balustrade**  
Full perf panel with welded base plated posts

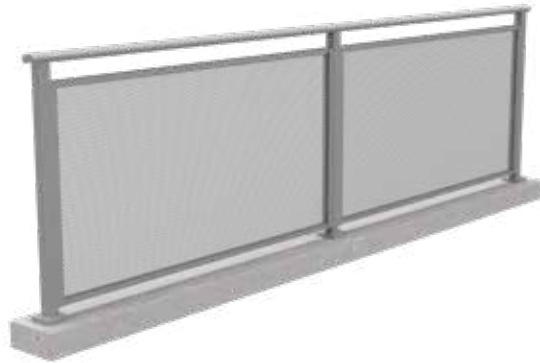

**02 Perf Balustrade**  
Perf with visibility gap and welded base plated posts

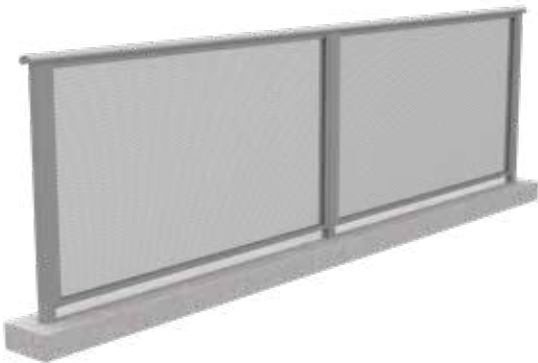

**03 Perf Balustrade**  
Full perf panel with core drilled posts

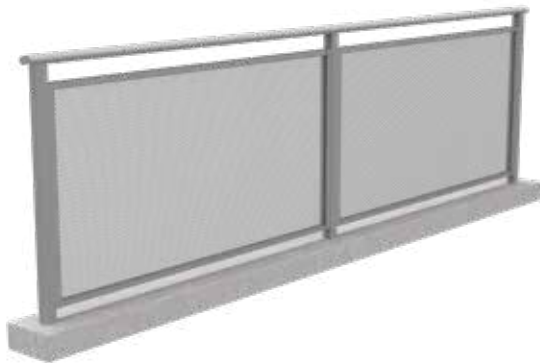

**04 Perf Balustrade**  
Perf with visibility gap and core drilled posts

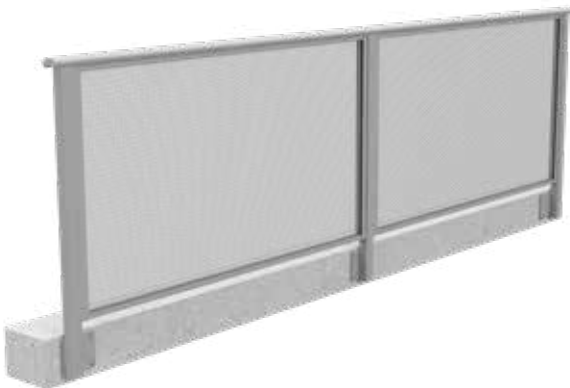

**05 Perf Face Mount**  
Full perf panel with face mount

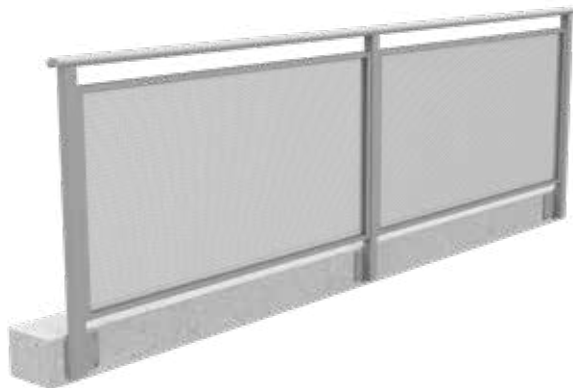

**06 Perf Face Mount**  
Perf with visibility gap with face mount



# FINISHES

## Our colour range

**Premium Perf Balustrade** is stocked in 2 popular powder coat finishes being Satin Black and Monument.

For Satin Black, posts and framing is Interpon Satin Black GN150A finish with the perforated infill panel being Textura black finish.

For Monument Matt posts and framing is Interpon Monument Matt GL229A finish with the perforated infill panel being Textura monument finish.

Genuine Akzo Nobel/Interpon powder is used with Interpon D1000 manufacturer warranties provided.

Extrusions are produced to the chemical composition, mechanical properties and dimensional tolerances of AS-NZS 1866-1997.



BLACK

(B)

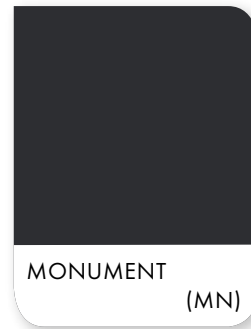

MONUMENT

(MN)





# PREMIUM PERF BALUSTRADE

- 1 **75x30mm top rail**  
(available oval or rectangle profile)
- 2 **Undercapping rail**
- 3 **75x30mm end cap**  
(available to suit oval or rectangle profile)
- 4 **10g x 16mm wafer SS304 screws**  
(used for various fixing applications)
- 5 **12gx25mm screws for fixing undercapping to posts**
- 6 **Perforated infill panel**
- 7 **38x25mm framing for infill panel**
- 8 **Snap-bead to suit 38x25mm framing**
- 9 **U channel**  
(into which 38x25mm frame fits inside)
- 10 **50x50 aluminium post**  
(core drill, welded base plate or face mount posts)
- 11 **2 part domical cover**  
(\*\* if using base plated posts; use a dress ring if core drill post)

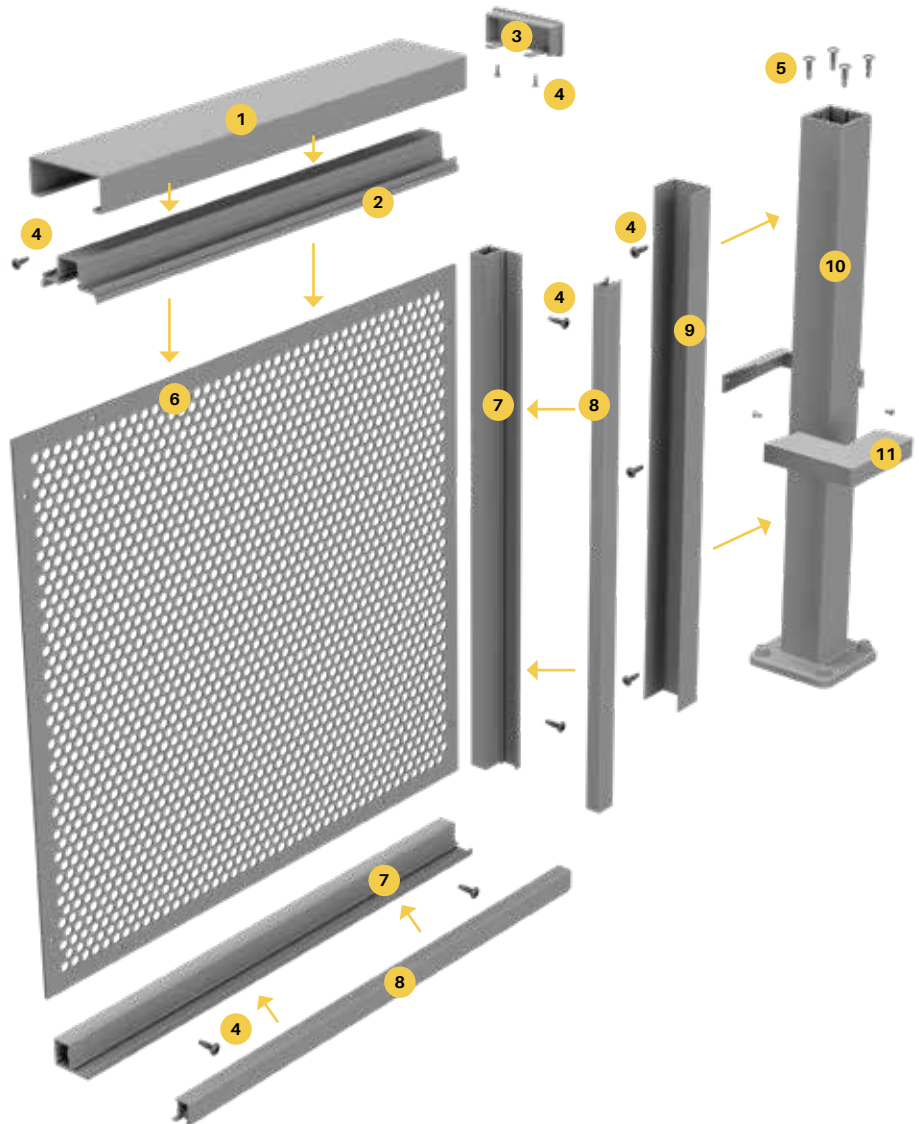



# PREMIUM PERF BALUSTRADE

## Full post with base plate (welded)

1050mm H

**Satin Black or Monument Matt finish**

Order Code: AR-1050-FPBP-B (Black)

AR-1050-FPBP-MN (Monument)

- Sturdy base plated post at 1050mm high overall
- Simply cut top of post to reduce height if needed
- Made from Alloy 6106 T6: premium & rigid alloy
- 3.2mm wall thickness post: 50x50mm profile
- 100x100mm base plate 10mm thick welded on; 4 x 11mm diameter fixing holes
- Screw flutes in extrusion allow non-weld affixing of top rail

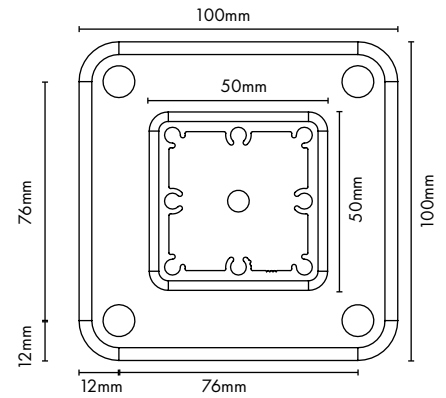
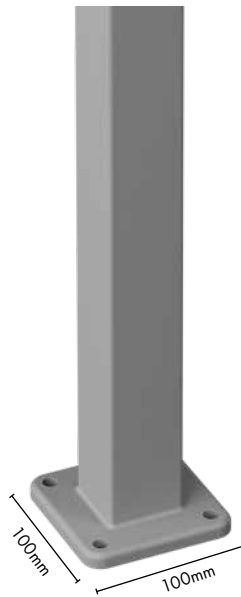

FINISHES



## 5800mm long – Full post

50x50x3.2mm

**Satin Black or Monument Matt finish**

Order Code: AR-5800-FP-B (Black)

AR-5800-FP-MN (Monument)

- 5800mm long post: suits core drill installation  
Cut to required lengths
- Made from Alloy 6106 T6: premium & rigid alloy
- 3.2mm wall thickness post: 50x50mm profile
- Screw flutes in extrusion allow non-weld affixing of top rail

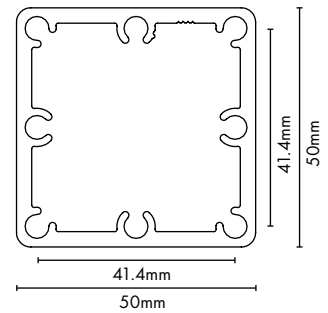

lxx = 214.10 x 10E3 mmE4  
lyy = 214.28 x 10E3 mmE4

FINISHES



## Half post

50x25x3mm

**Satin Black or Monument Matt finish**

Order Code: A50-1400D-HALF-B (Black)

A50-1400D-HALF-MN (Monument)

A50-5800D-HALF-B (Black)

A50-5800D-HALF-MN (Monument)

- 50x25mm half post available at 1400mm or 5800mm long  
– easily cut to required length
- 3mm rear wall thickness
- Use at start or end of spans with half post fixed to a wall or existing post
- Screw fix off sideways to structure via recessed post cavity. Infill snaps into cavity to hide fixings
- Handrail undercapping rail screw fixes into the 2 x screw flutes in half post
- Made from alloy 6106 T6

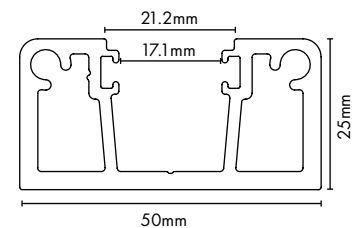

lxx = 32.82 x 10E3 mmE4  
lyy = 130.40 x 10E3 mmE4

FINISHES





# PREMIUM PERF BALUSTRADE

## Post infill

1400mm long

**Satin Black or Monument Matt finish**

Order Code: **A50-1400-INF-B (Black)**

**A50-1400-INF-MN (Monument)**

- Snap in infill mates with half post
- Easily cut infill to required post cavity length
- Infill covers half post screw fixings
- Made from alloy 6063 T6

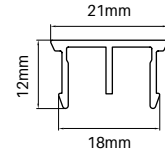

### FINISHES



### STEP 1

Position half post against wall/post and screw fix. Pilot hole drilling required.

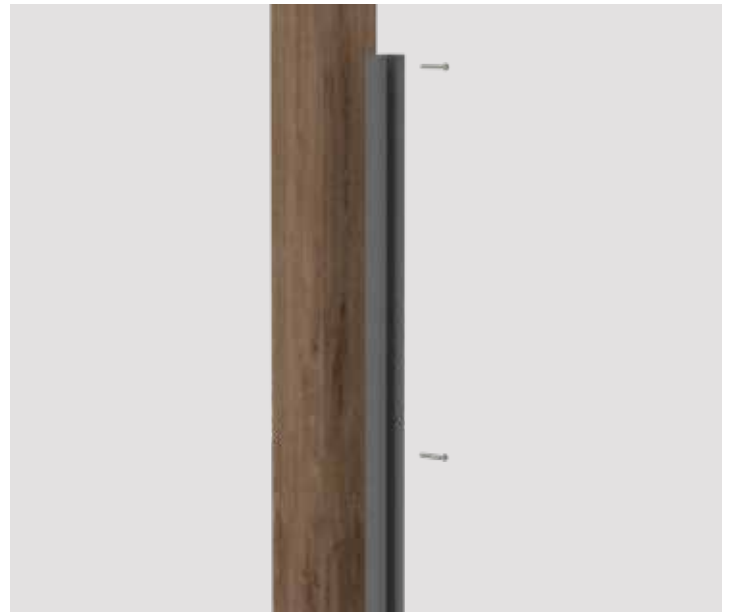

### STEP 2

Recommended minimum of 3 x fixings to structure.



### STEP 3

Snap infill into cavity to hide screw fixings.



### STEP 4

Half post installed - Handrail undercapping screw fixes into 2 x screw flutes in top of half post.





# PREMIUM PERF BALUSTRADE

## Mid face mount post

1500mm H

**Satin Black or Monument Matt finish**

Order Code: AR-1500-FMID-B (Black)

AR-1500-FMID-MN (Monument)

- 1500mm long face mount MID post
- Heavy duty 50x50mm aluminium profile: 4mm wall post thickness
- 150x150mm welded on plate: 10mm thick
- Made from alloy 6106T6: premium & rigid alloy
- 4 x 13mm diameter fixing holes
- Easily cut down height of post to required length

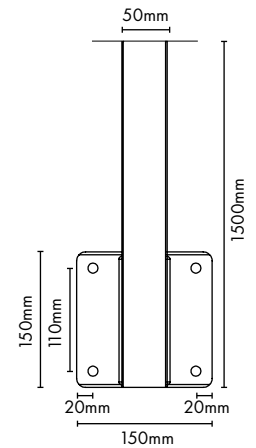
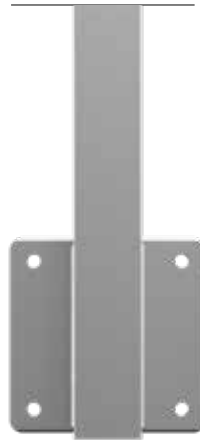

FINISHES



STEP 1

Install anchors ensuring alignment to post plate holes



STEP 2

Fix off with dome nuts if using threaded rod or lag screw anchors

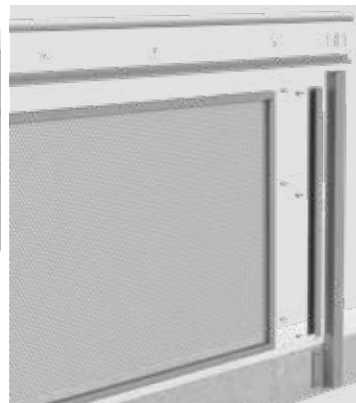

STEP 3

Install perf panels & brackets



STEP 4

Finished installation

## Face mount – 1 left & 1 right

1500mm H

**Satin Black or Monument Matt finish**

Order Code: AR-1500-FMLR-B-2PK (Black)

AR-1500-FMLR-MN-2PK (Monument)

- 1500mm long face mount END posts - LEFT & RIGHT
- Heavy duty 50x50mm aluminium profile: 4mm wall post thickness
- 160mmWx150Hmm welded on offset plates: 10mm thick
- Made from alloy 6106T6: premium & rigid alloy
- 4 x 13mm diameter fixing holes
- Easily cut down height of post to required length
- Offset plates enable posts to be positioned at absolute ends of face mount installations
- Screw flutes in post extrusion allows for non-weld affixing of handrail
- Sold as a 2 pack (left & right)

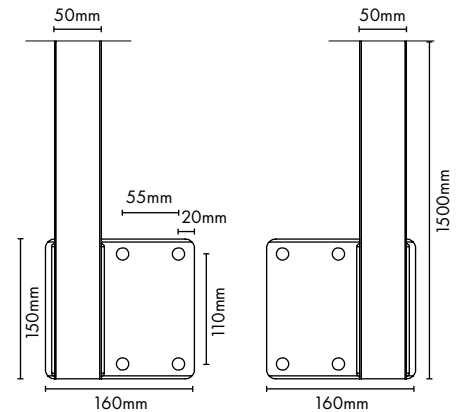
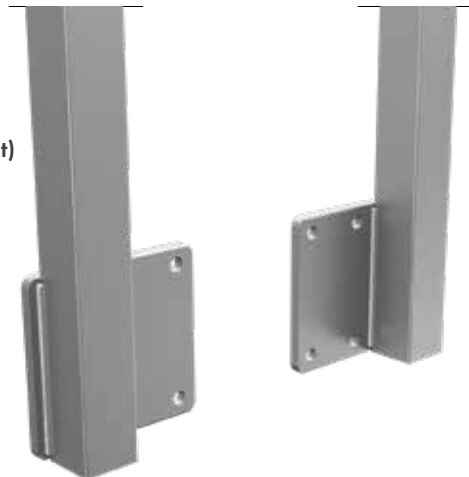

FINISHES









# PREMIUM PERF BALUSTRADE

## 5800mm rectangular handrail

WITH CHANNEL INSERT

**Satin Black or Monument Matt finish**

Order Code: **A50-5800-RHR-B (Black)**

**A50-5800-RHR-MN (Monument)**

- 5800mm long 75x30mm rectangular profile
- Made from Alloy 6063 T6
- 2 part railing: (1) undercapping rail is screwed to top of post & (2) rectangular handrail is then snapped onto undercapping rail
- Easy to install

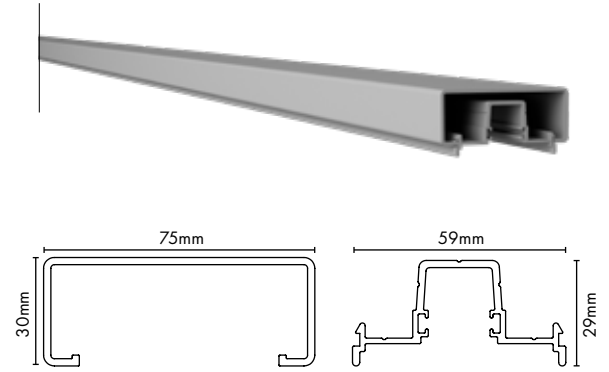
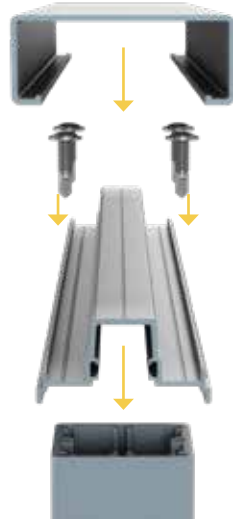

FINISHES



BLACK

MONUMENT

## Oval handrail

WITH CHANNEL INSERT

**Satin Black or Monument Matt finish**

Order Code: **A50-5800-OHR-B (Black)**

**A50-5800-OHR-MN (Monument)**

- 5800mm long 75x30mm oval profile
- Made from Alloy 6063 T6
- 2 part railing: (1) undercapping rail is screwed to top of post & (2) oval handrail is then snapped onto undercapping rail
- Easy to install

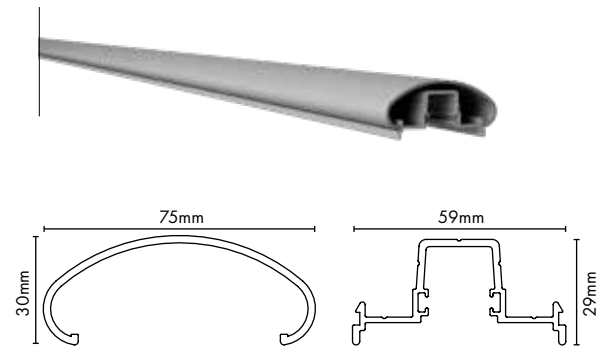
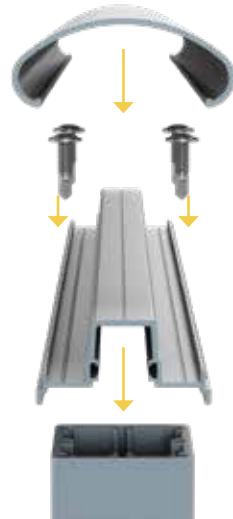

FINISHES



BLACK

MONUMENT



# PREMIUM PERF BALUSTRADE

## Premium Perf Balustrade 38x25mm

### FRAMEKIT

**Satin black or Monument matt powder coat**

Order Code: PP-BAL-FRAMEKIT-B/MN

- Kit frames perf balustrade infill panel
- 2 part frame design enables hidden screw fixing of perf infill sheet to frame. Fixing screws are covered by snap in cover. Finished frame profile is 38x25mm around the entire perimeter of infill sheet.
- Framed infill panel fits into U channel both sides. U channel is affixed to posts.
- Frame kit suits installation into 'daylight opening' width of 1750mm
- Frame kit is easily height and width adjustable. Simply cut to size.

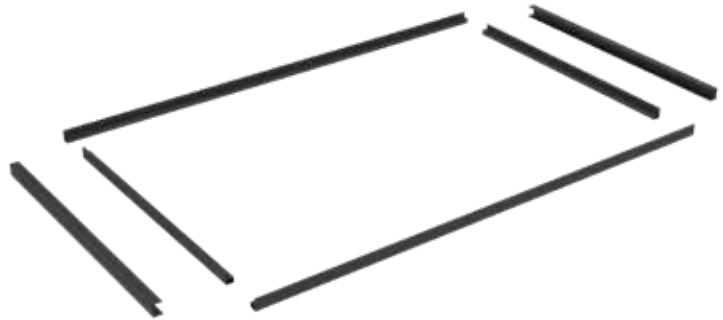

### KIT CONSISTS OF

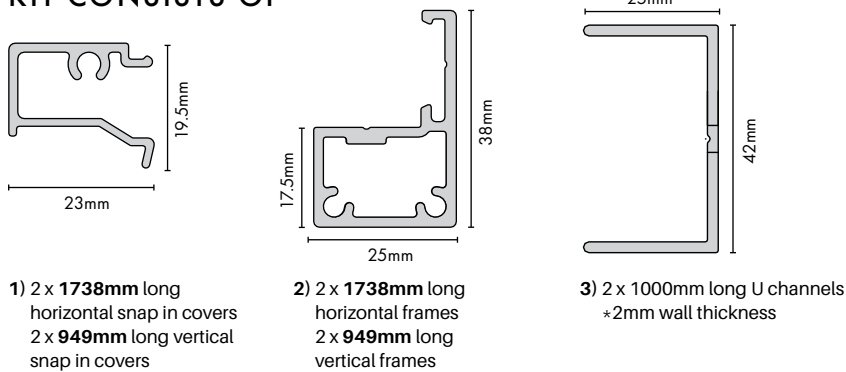

1) 2 x **1738mm** long horizontal snap in covers  
2 x **949mm** long vertical snap in covers

2) 2 x **1738mm** long horizontal frames  
2 x **949mm** long vertical frames

3) 2 x 1000mm long U channels  
\*2mm wall thickness

\*\*Wafer screws for fixing panel to frame sold separately. Refer code: PP-SCREW-B/MN-50PK

### INNOVATIVE 2-PART FRAME



#### STEP 1

Place perf infill sheet against centre frame wall



#### STEP 2

Screw off sheet and snap in cover



#### STEP 3

Completed 38 x 25mm profile with hidden screw fixing

## 1400mm long aluminium infill / spacer

**Satin Black or Monument Matt finish**

Order Code: A50-1400-INF-B (Black)

A50-1400-INF-MN (Monument)

For "3 rail installations", snap infill into uncapping rail void as there is a gap between the underside of capping rail and perf panels.

TIP: infill is 1400mm wide so if opening size is wider than 1400mm, 2 x infills are required and it is suggested to cut equally so the join is at midpoint of undercapping.

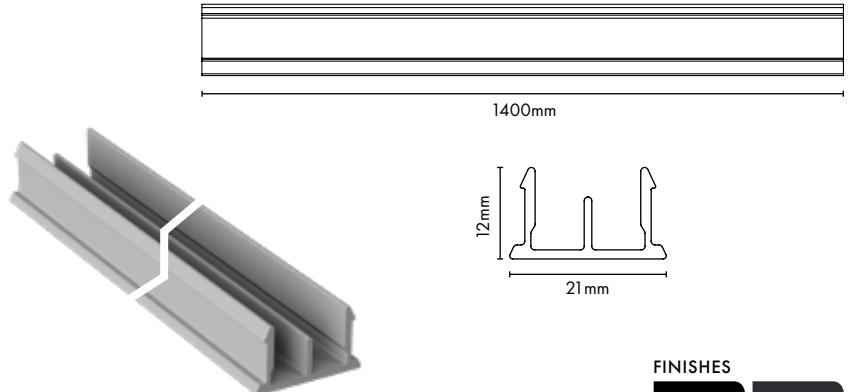

#### FINISHES



BLACK

MONUMENT

# PREMIUM PERF BALUSTRADE

## Premium Full Perf Balustrade Infill Sheet

1726mm W x 988mm H

**Matt Black or Monument Matt Texture  
Powder Coat**

Order Code: **PP-BAL-INFILL-B/MN**

- Premium marine grade alloy 5052 H32; 2.5mm thick
  - Akzo Nobel textured powder coat
  - 9mm diameter precision punched holes
  - Excellent visibility through punched panel; great alternative to glass
  - Minimal cleaning required + shatter proof
  - 20 x fixing screws are required per panel to fix to framing kit. If panel height/width adjusted, less screws may be required
  - Perimeter holes are prepunched at 325mm spacing around the sheet for ease of screw fixing to frame kit
  - With assembled framing, panel is 1738mmW x 1000mmH - framing sold separately. With U channels at sides, suits 'daylight opening' of 1750mm wide.
  - Height and width adjustable: simply cut to size. Refer 'fabrication overview' section
- TIP: Refer page 128-129 for detailed info on panel size adjustment.

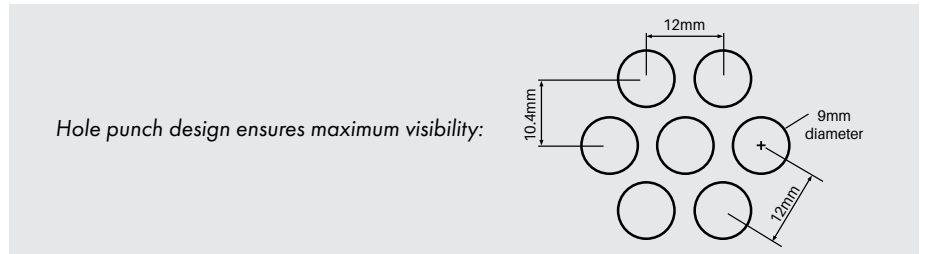
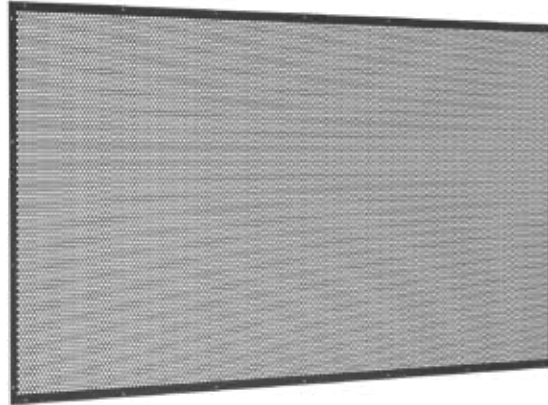

## Rectangular end cap

ALUMINIUM

Suits 75x30mm rectangular handrail

**Satin Black or Monument Matt finish**

Order Code: **A50-ECA-R-B (Black)**

**A50-ECA-R-MN (Monument)**

- End cap made from aluminium die cast
- Suits 75x30mm rectangular handrail
- Features protruding fins at bottom so end cap may be mechanically fixed to undercapping rail using 10g x 16mm screws (sold separately PP-SCREW-B/MN-50PK)

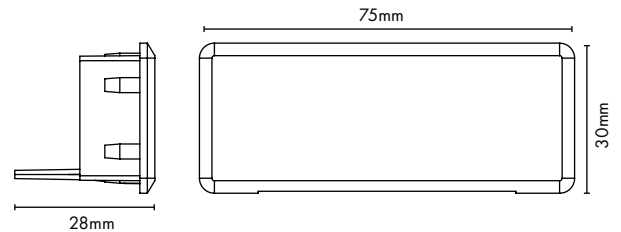

FINISHES



## Offset bracket

ALUMINIUM

2 PACK (1 LEFT & 1 RIGHT BRACKET)

Suits 75x30mm rectangular handrail

**Satin Black or Monument Matt finish**

Order Code: **A50-BRACKET-R-B-2PK (Black)**

**A50-BRACKET-R-MN-2PK (Monument)**

- Offset bracket made from aluminium die cast
- Suits 75x30mm rectangular handrail
- Caps over top of handrail and features offset leg for fixing to wall/post
- Mechanically fix bracket to handrail by screwing through side of bracket into handrail
- 2 x 7mm diameter holes for fixing to post/wall
- Sold as a 2 pack - 1 x left and 1 x right bracket

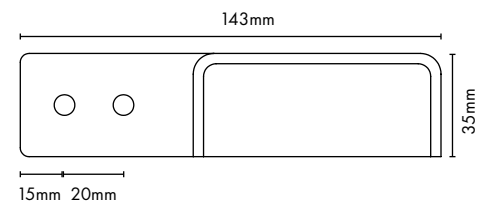

FINISHES





# PREMIUM PERF BALUSTRADE

## Oval end cap

ALUMINIUM

Suits oval handrail

**Satin Black or Monument Matt finish**

Order Code: **A50-ECA-O-B (Black)**

**A50-ECA-O-MN (Monument)**

- End cap made from aluminium die cast
- Suits 75x30mm oval handrail
- Features protruding fins at bottom so end cap may be mechanically fixed to undercapping rail using 10g x 16mm screws (sold separately PP-SCREW-B/MN-50PK)

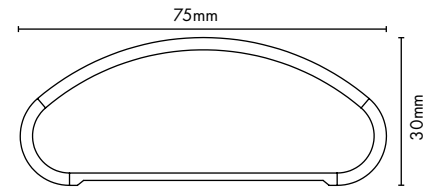
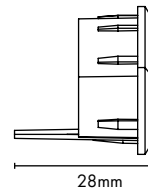

FINISHES



## Offset bracket

ALUMINIUM

2 PACK (1 LEFT & 1 RIGHT BRACKET)

Suits oval handrail

**Satin Black or Monument Matt finish**

Order Code: **A50-BRACKET-O-B-2PK (Black)**

**A50-BRACKET-O-MN-2PK (Monument)**

- Offset bracket made from aluminium die cast
- Suits 75x30mm oval handrail
- Caps over top of handrail and features offset leg for fixing to wall/post
- Mechanically fix bracket to handrail by screwing through side of bracket into handrail
- 2 x 7mm diameter fixing holes to post/wall
- Sold as a 2 pack - 1 x left and 1 x right bracket

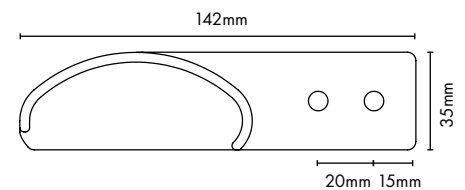
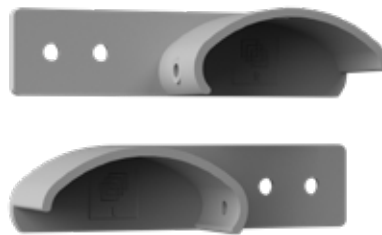

FINISHES



STEP 1

Offset bracket caps over installed handrail.

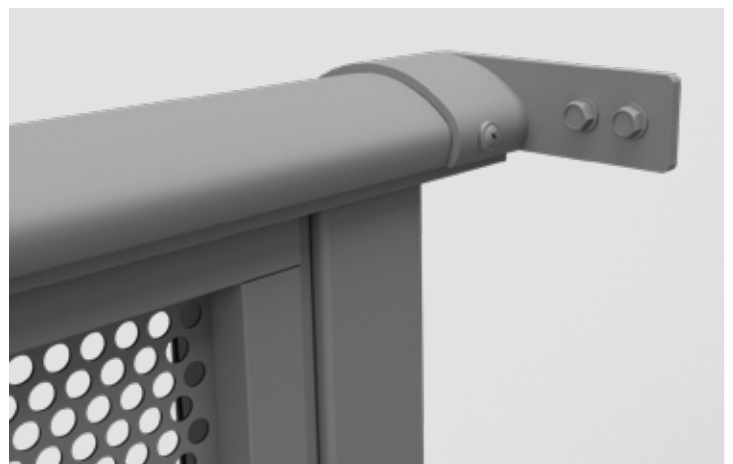

STEP 2

Screw fix offset bracket to (1) handrail and (2) post/wall.



# PREMIUM PERF BALUSTRADE

## Wall Plate

ALUMINIUM

Suits oval & rectangular handrail

**Satin Black or Monument finish**

Order Code: A50-WP-B (Black)

A50-WP-MN (Monument)

- Affixes internally to undercapping rail with only the bottom section visible – provides a slimline finish
- Affix to undercapping rail firstly and then affix to wall. Oval or rectangular rail handrail snaps over the undercapping rail with wall plate.

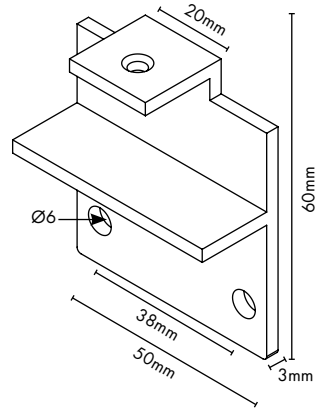

FINISHES

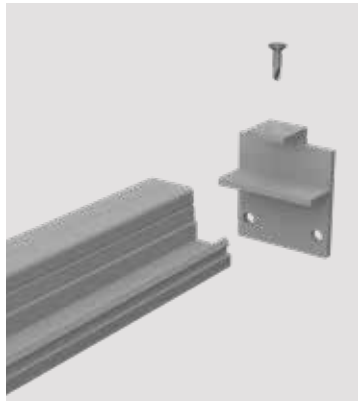

STEP 1

Countersink the top hole of the wall plate. Insert wall plate onto undercapping rail and fix off through hole located on top of wall plate using a countersunk screw (not supplied).

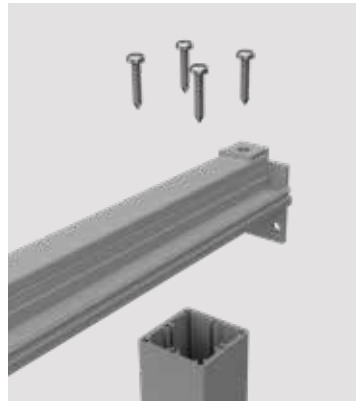

STEP 2

Screw fix undercapping rail to post via 4 x screw flutes in corners of posts. Ensure wall plate neatly fits against wall/post. Use 12gx25mm panhead screw. (refer stock code AR-SCR-BR)



STEP 3

Affix wall plate to wall/post using 2 x screws. Use suitable screws to fix having regard to structure.



STEP 4

Clip on oval or rectangular handrail onto undercapping rail. Wall plate is hidden except for bottom section.

## Two part domical cover

POWDER COATED ALUMINIUM

**Black, Monument**

Order Code: XP-DC-2P-B (Black)

XP-DC-2P-MN (Monument)

- Suits 50x50mm post with 100x100mm base plate
- 106x106mm outer – 52x52mm inner – Alloy ADC12
- Cover can be fitted to posts after balustrade posts are installed

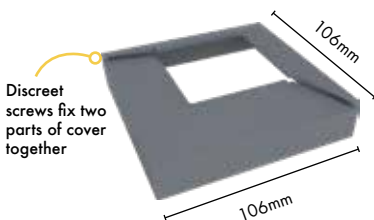

## Post dress rings

POWDER COATED ALUMINIUM

**Black, Monument**

Order Code: XP-DR-B (Black)

XP-DR-MN (Monument)

- Suits 50x50mm core drill posts
- 100mm x 100mm outer – 52mm x 52mm inner

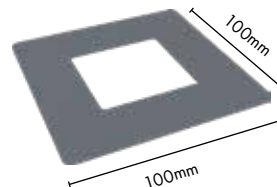



# PREMIUM PERF BALUSTRADE

## Self drilling wafer screws

10Gx16mm – BAG OF 50

**Satin black or Monument heads**

Order Code: PP-SCREW-B/MN-50PK

- Bags of 50 – 10G x 16mm self drilling wafer SS304 screw
- Powder coated heads for neat finish
- Used for a variety of applications:

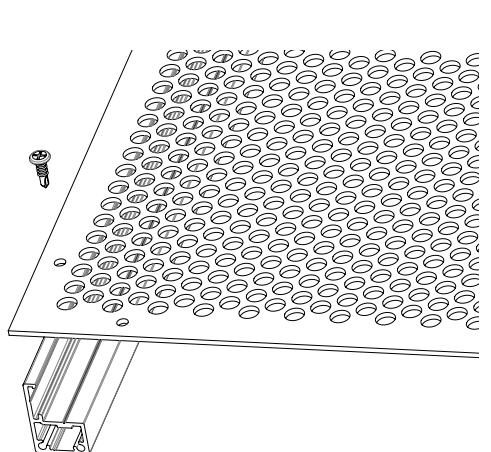

1) Fixes perforated infill sheet to framing kit

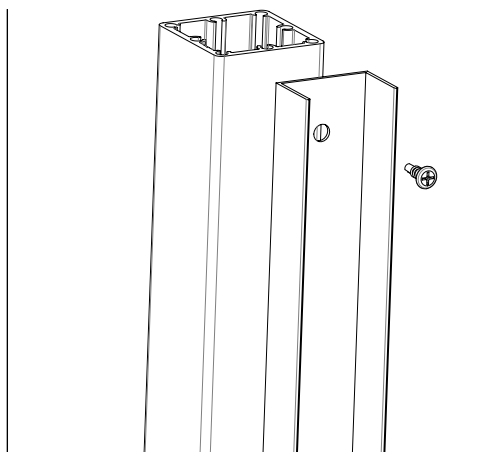

2) Fixes U channels to aluminium 50x50mm posts

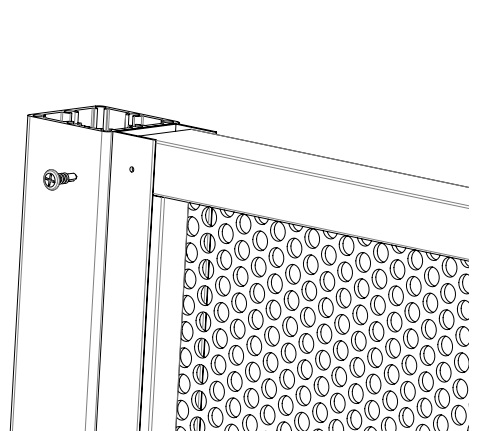

3) Fixes together framing kit vertical sides and U channel

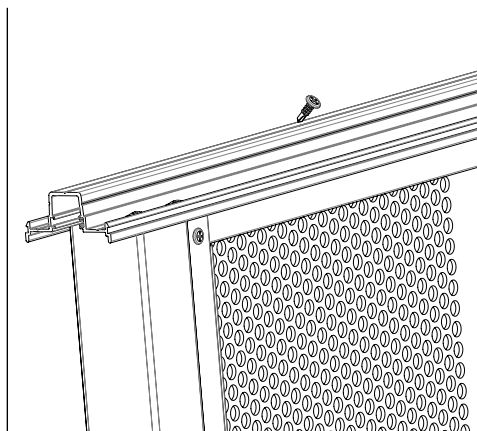

4) Fixes undercapping rail to framing kit

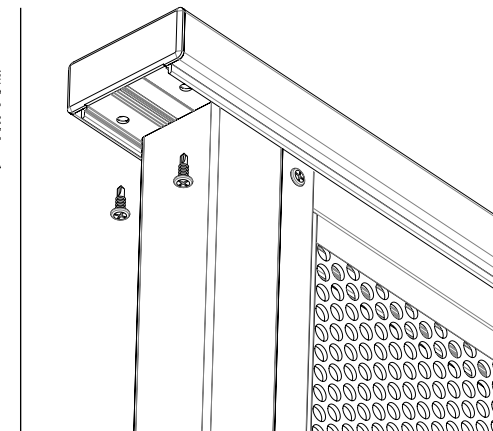

5) Fixes end cap to undercapping rail

## 12g x 25mm panhead screw with square drive head

SS304HC

PACK OF 50

**Mill**

Order Code: AR-SCR-BR-50PK

- SS304 panhead screw 12gx25mm with square drive head
- Use for fixing of undercapping rail to top of post. Screws are hidden by snap on rectangular or oval rail.

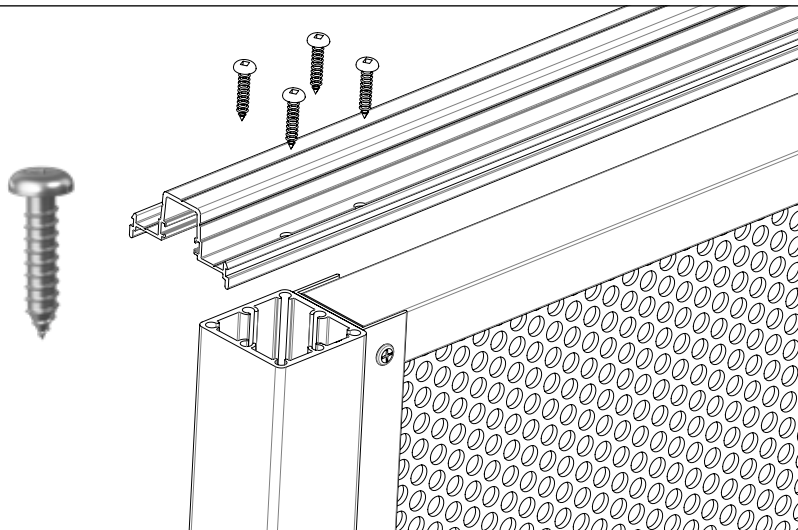



# PREMIUM PERF BALUSTRADE

## Driver bit

Order Code: DB-PH3

- Driver bit to suit Phillips #3 screw head



## Square head driver bit

Order Code: DB-SQ3.4

- Driver bit to suit 3.4mm square screw head hole
- Suits AR-SCR-BR-50PK screws



## Touch Up Paint

150g SPRAY CAN

**Black or Monument finish**

Order Code: PAINT-B (Black)

PAINT-MN (Monument)

- Colour match touch up paint



## M10 Timber fixing kit

4 PACK – SS316

Order Code: S-110LAG-4PK

- M10 x 110mm timber lag screws x4 with nuts and washers
- Hex drive head in screw



## M10 Concrete fixing kit

4 PACK – SS316

Order Code: S-120ROD-4PK

- M10 x 120mm concrete threaded rods x4 with nuts and washers
- Adhere into concrete with suitable chemical anchor





# FABRICATION OVERVIEW

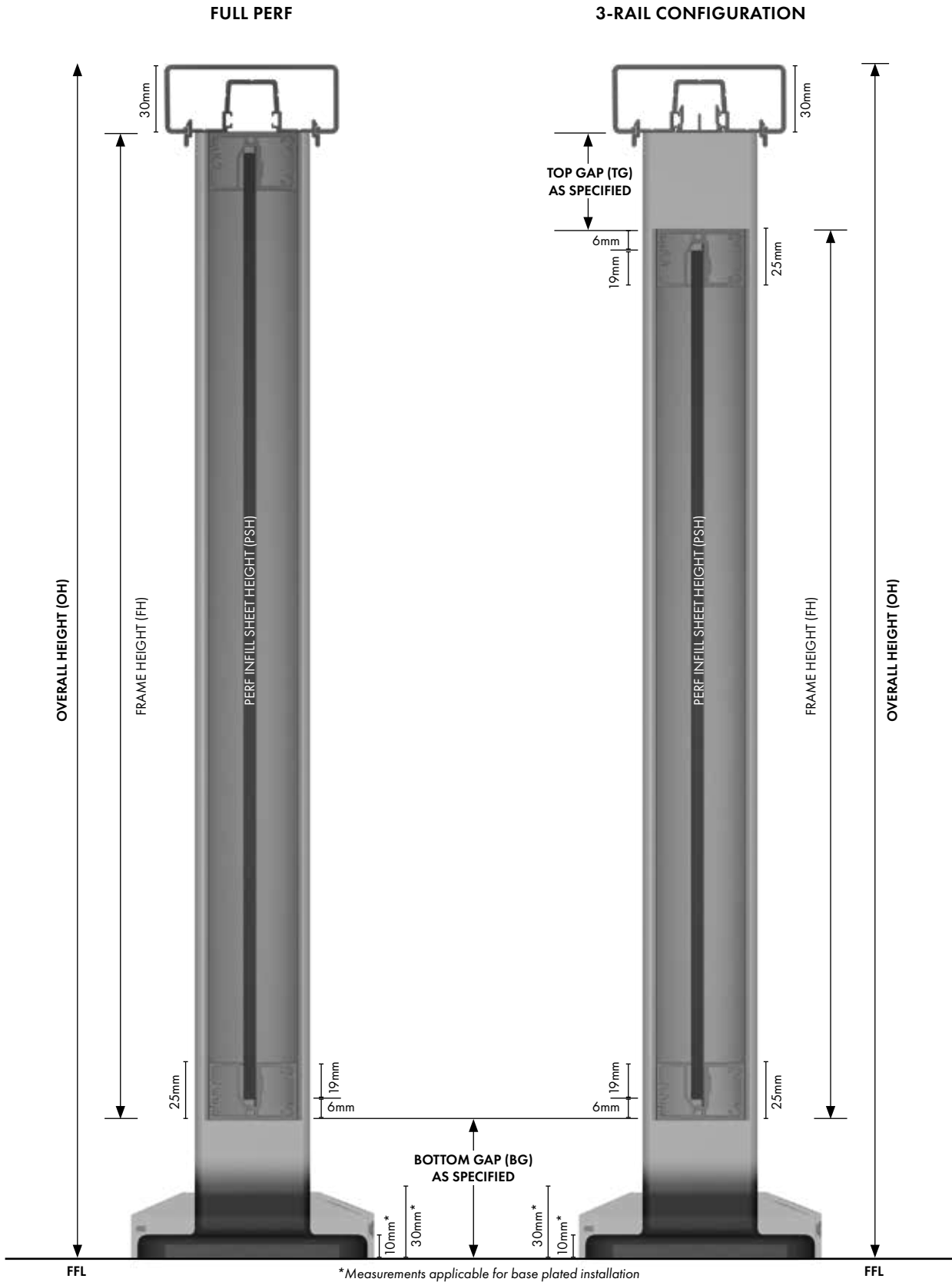

**FRAME HEIGHT (FH) =**  
Overall Height (OH) – Bottom Gap (BG) – 30mm

**PERF INFILL SHEET HEIGHT (PSH) =**  
Frame Height (FH) – 12mm

**FRAME HEIGHT (FH) =**  
Overall Height (OH) – Bottom Gap (BG) – Top Gap (TG) – 30mm

**PERF INFILL SHEET HEIGHT (PSH) =**  
Frame Height (FH) – 12mm





NOTE – Select finish code:  
(EG AR-1050-FPBP-B for black)

# ORDER CODES



Order Code	Description	Colours
AR-1050-FPBP-B/MN	1050mm high – 50x50mm post with weld on 100x100mm base plate	
AR-5800-FP-B/MN	5800mm long – 50x50mmx3.2mm full post	
AR-1500-FMID-B/MN	1500mm long – 50x50x4mm MID post with welded on 150x150 face mounting plate	
AR-1500-FMLR-B/MN-2PK	1500mm long – 50x50x4mm END posts with welded on 160x150 face mounting plates – LEFT & RIGHT	
A50-1400D-HALF-B/MN	1400mm long – 50x25x3mm half post	
A50-5800D-HALF-B/MN	5800mm long – 50x25x3mm half post	
A50-1400-INF-B/MN	1400mm long – 21x12mm infill	
A50-5800-RHR-B/MN	5800mm long rectangular handrail with undercapping rail	
A50-5800-OHR-B/MN	5800mm long oval handrail with undercapping rail	
PP-BAL-INFILL-B/MN	1726mm wide x 988mm perforated infill panel	
PP-BAL-FRAMEKIT-B/MN	38x25mm 2 part frame kit (includes complete panel frame & U channel)	
A50-ECA-R-B/MN	75 x 30mm rectangular end cap	
A50-BRACKET-R-B/MN-2PK	143 x 35mm rectangular handrail offset bracket	
A50-ECA-O-B/MN	75 x 30mm oval end cap	
A50-BRACKET-O-B/MN-2PK	142 x 35mm oval handrail offset bracket	
A50-WP-B/MN	Wall plate (attaches to undercapping rail)	
XP-DC-2P-B/MN	106 x 106mm two part domical cover	
XP-DR-B/MN	100 x 100mm dress ring	
PP-SCREW-B/MN	10gx16mm self drilling wafer screw – 50 pack	
AR-SCR-BR-50PK	12g x 25mm panhead screw with square drive head – 50 pack	
S-110LAG-4PK	M10 x 110mm long timber lag screw – 4 pack	
S-120ROD-4PK	M10 x 120mm thread rod with nuts/washers – 4 pack	
DB-PH3	Phillips #3 driver bit	
DB-SQ3.4	Square head driver bit	
PAINT-B/MN	Touch up paint	

FREE, EASY TO USE ESTIMATOR. EXCEL FORMAT. CONTACT US AND WE WILL EMAIL TO YOU!



- Quickly & accurately cost jobs
- Instant specification of materials list
- Take the time & hassle out of quoting



# PERF BALUSTRADE ASSEMBLY OVERVIEW

Based on maximum infill size with framing giving 1750mm wide daylight opening

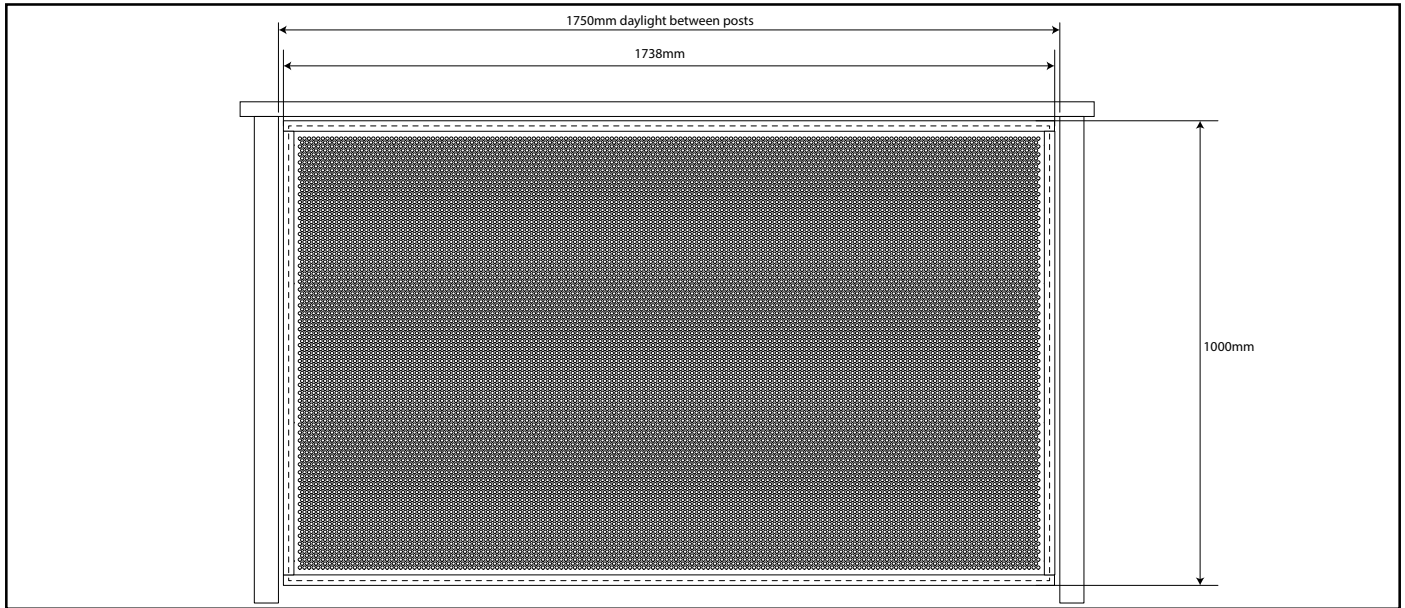

NOTE

Once assembled with framing, infill panels are 1738mm wide x 1000mm high.

With U channel installed both sides, infill panels fit into an 1750mm wide opening as standard. With 50x50mm posts, this equates to centre to centre of post being 1800mm wide.

For height and width adjustment, refer end of assembly guide.

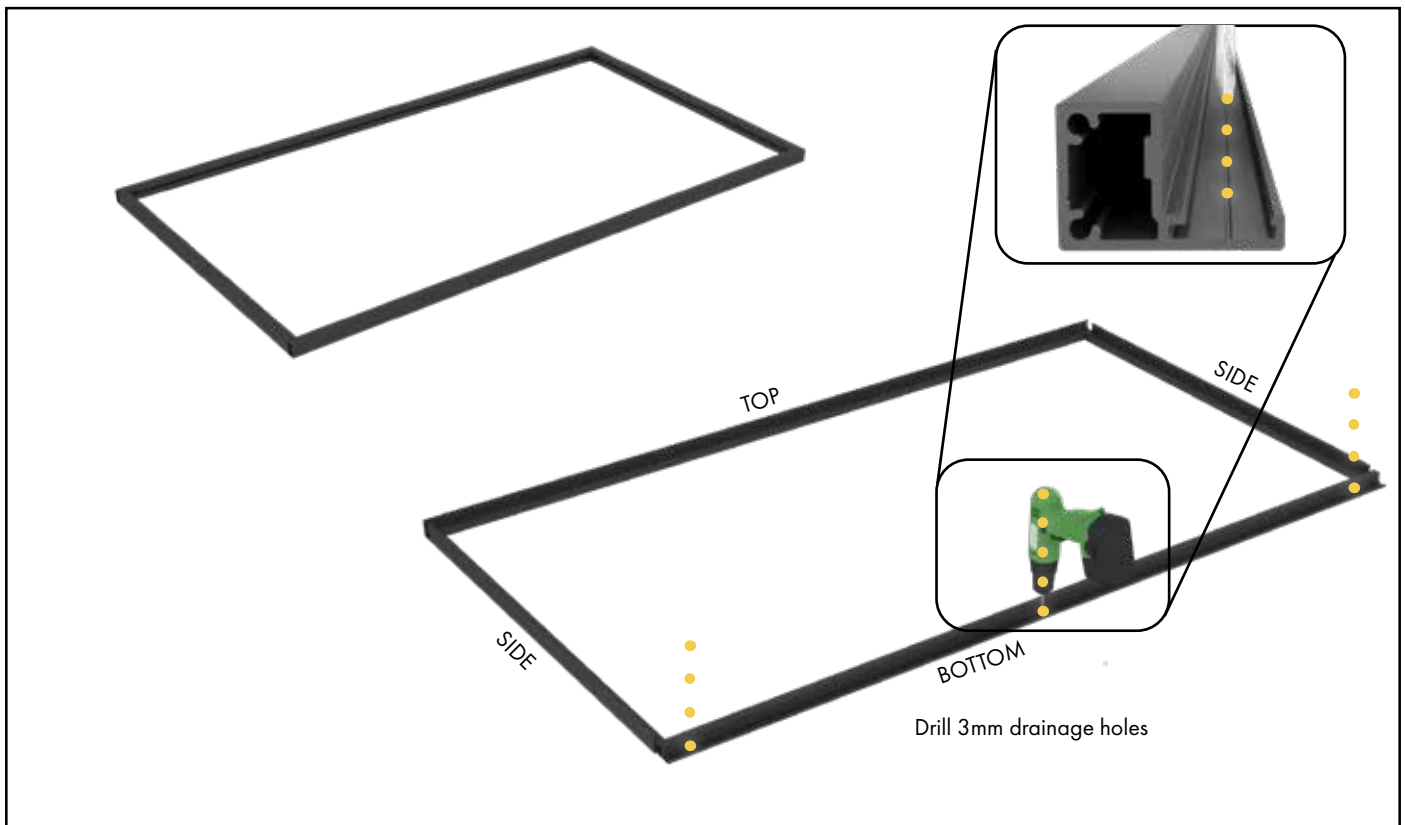

1

Lay out rails in picture frame (side rails inside top/bottom rails).

Drill 3mm drainage holes in bottom rail at 2 ends and midpoint.



# PERF BALUSTRADE ASSEMBLY OVERVIEW

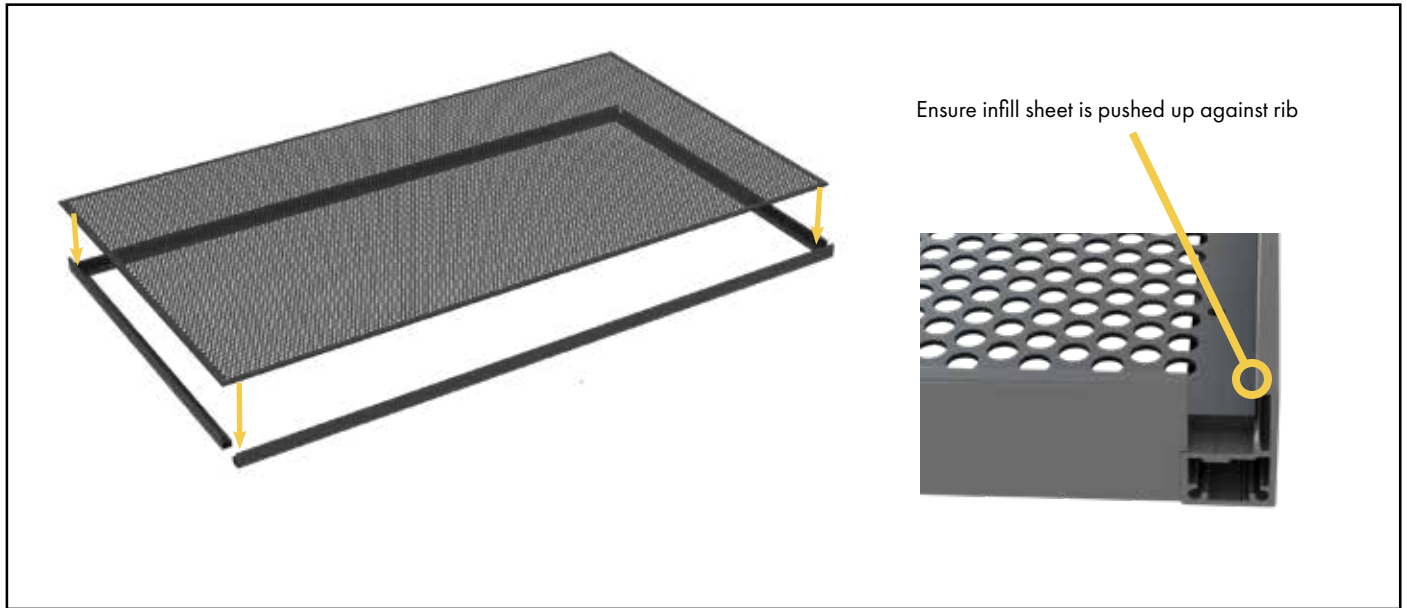

- 2** Place infill sheet in frame rebate, ensuring infill sheet is tight against rail rib on all 4 sides. Check square.

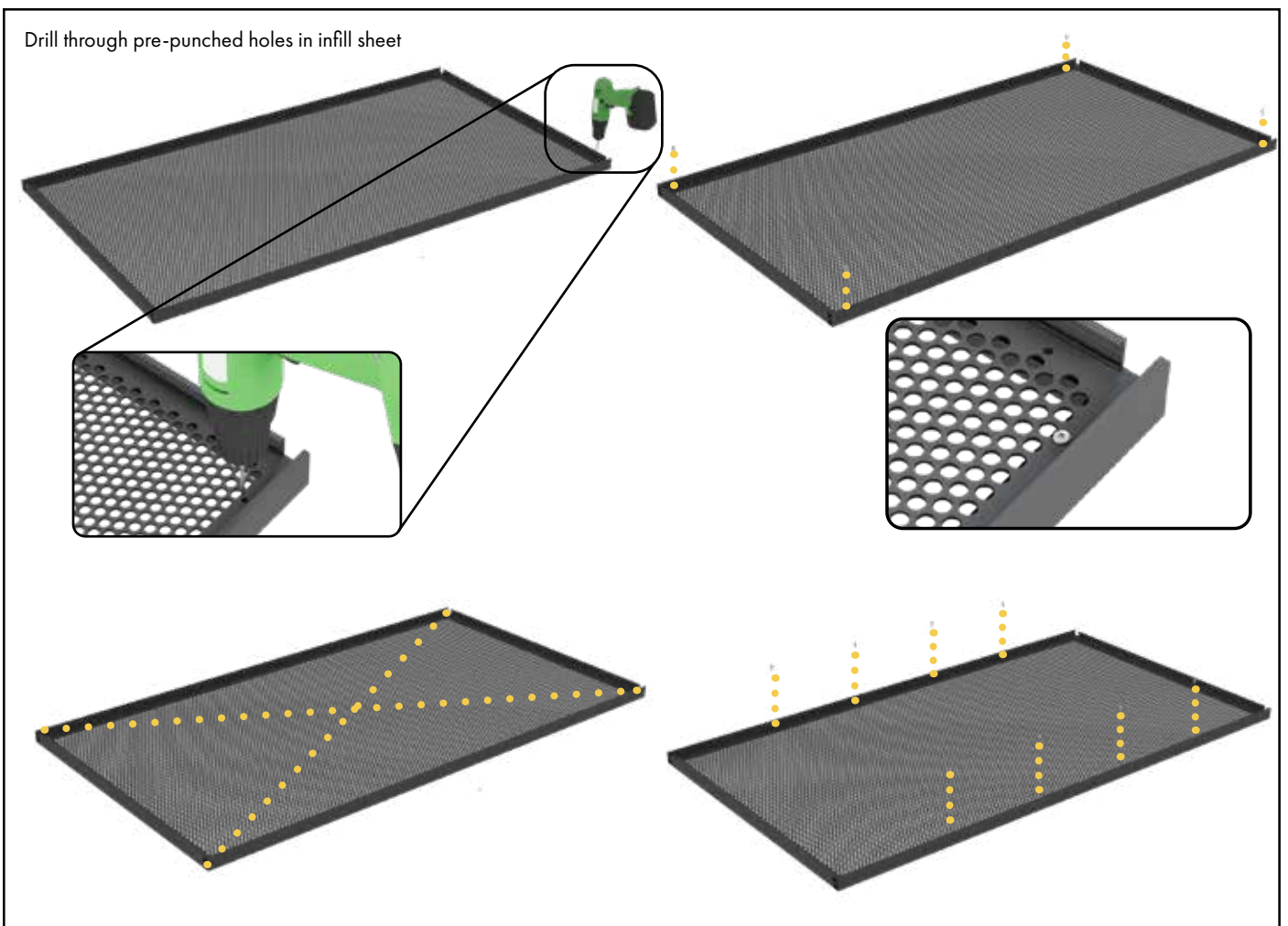

- 3** Drill 3mm pilot holes into the top and bottom outer frame rebate, aligning with the pre-punched holes in the infill sheet border. Start with the 4 outer holes and affix with self tapping wafer screws and check for squareness. Adjust as necessary before drilling and screwing the remaining holes.



# PERF BALUSTRADE ASSEMBLY OVERVIEW

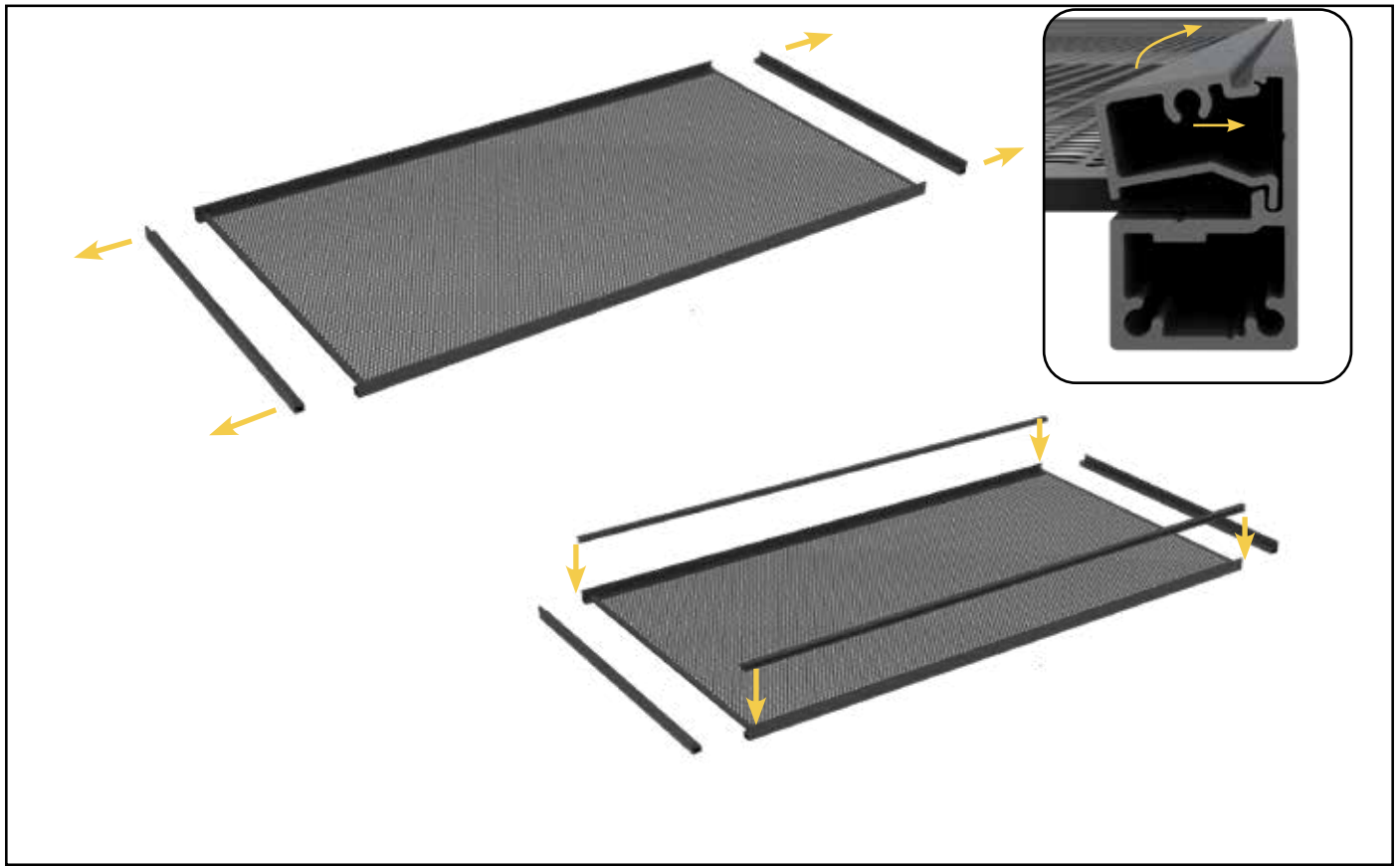

- 4** Remove the side rails from infill sheet temporarily and affix clip bead to top and bottom rail.  
Return side rails into position and ensure infill sheet is tight against rail ribs (both sides).

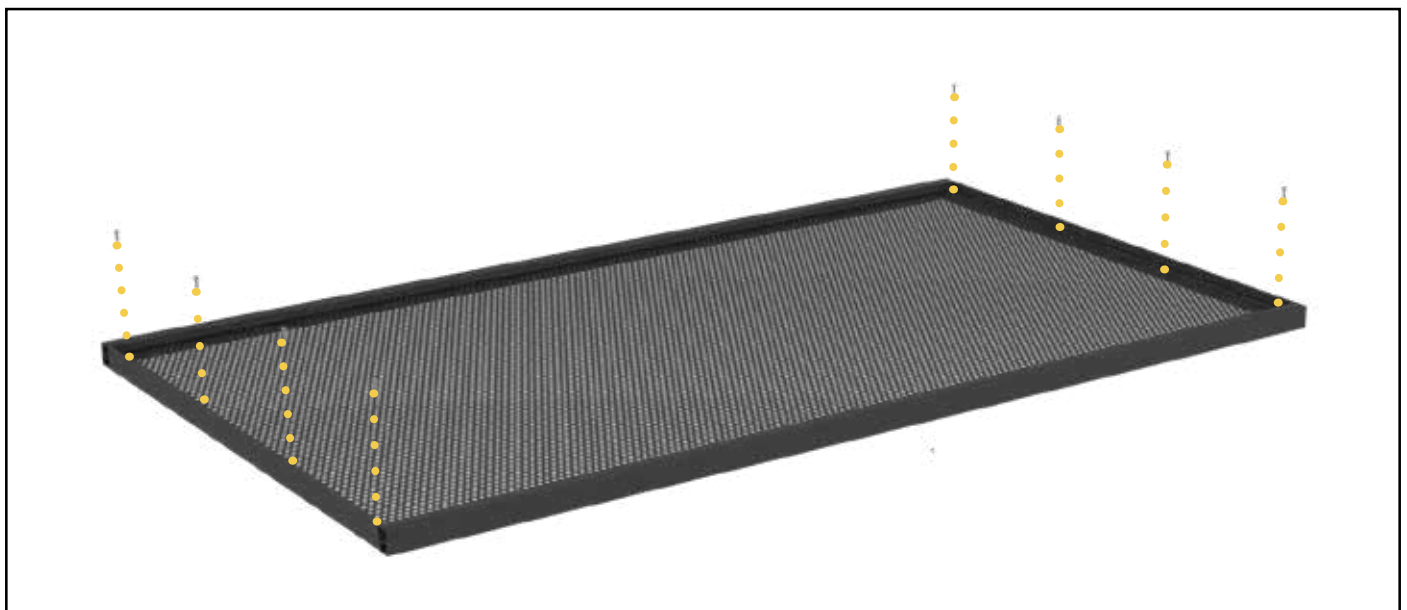

- 5** Drill 3mm pilot holes and affix infill sheet to side rails with self tapping wafer head screws using pre-punched fixing holes.  
Check panel is square before and after tightening. Adjust as necessary.



# PERF BALUSTRADE ASSEMBLY OVERVIEW

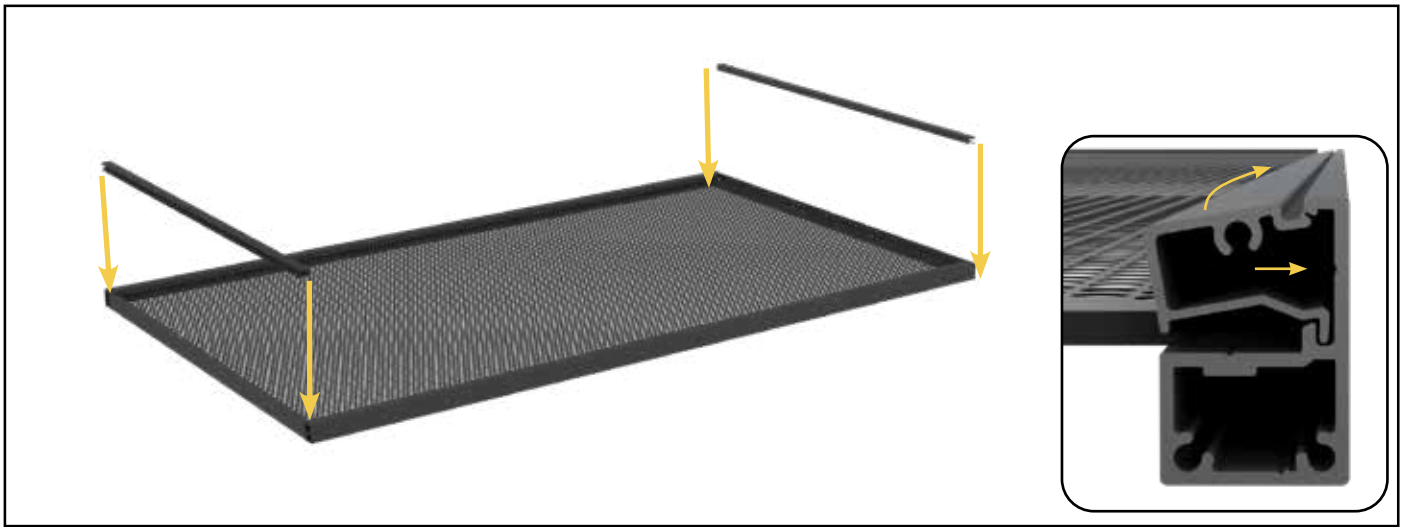

**6** Affix clip bead to side rails.



**7** Screw fix U-Channel to aluminium posts using self tapping wafer head screws having regard to the desired gap between the bottom rail and the finished ground level.  
Fix off vertical U channel to posts at 3 points – bottom, middle and top.  
NOTE: Allow for suitable fixings if installing to varied post materials.

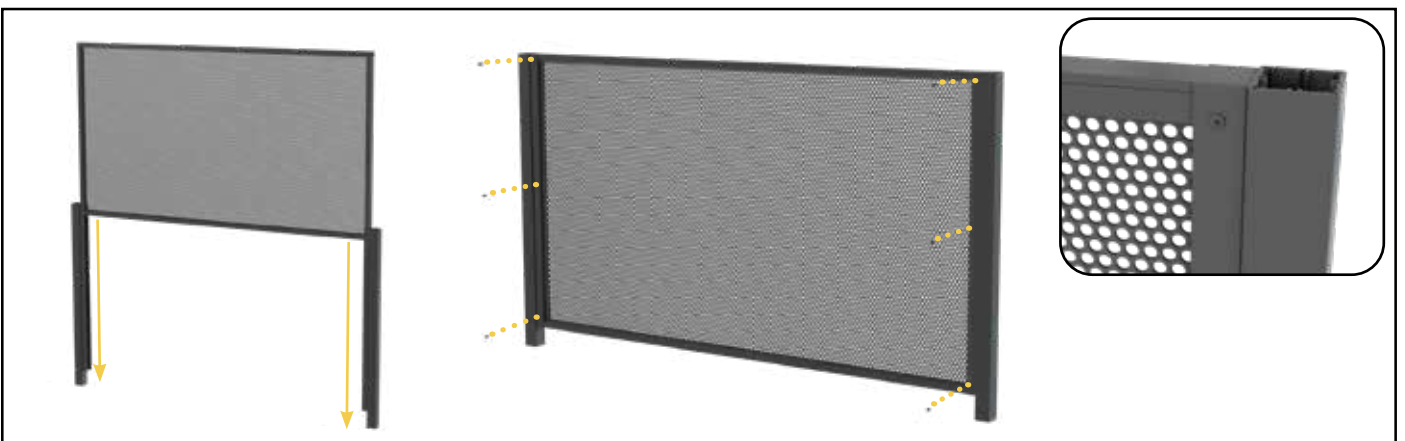

**8** Lower panel into U Channel and fix off using wafer head screws either side of panel at top, middle and bottom.



# PERF BALUSTRADE ASSEMBLY OVERVIEW

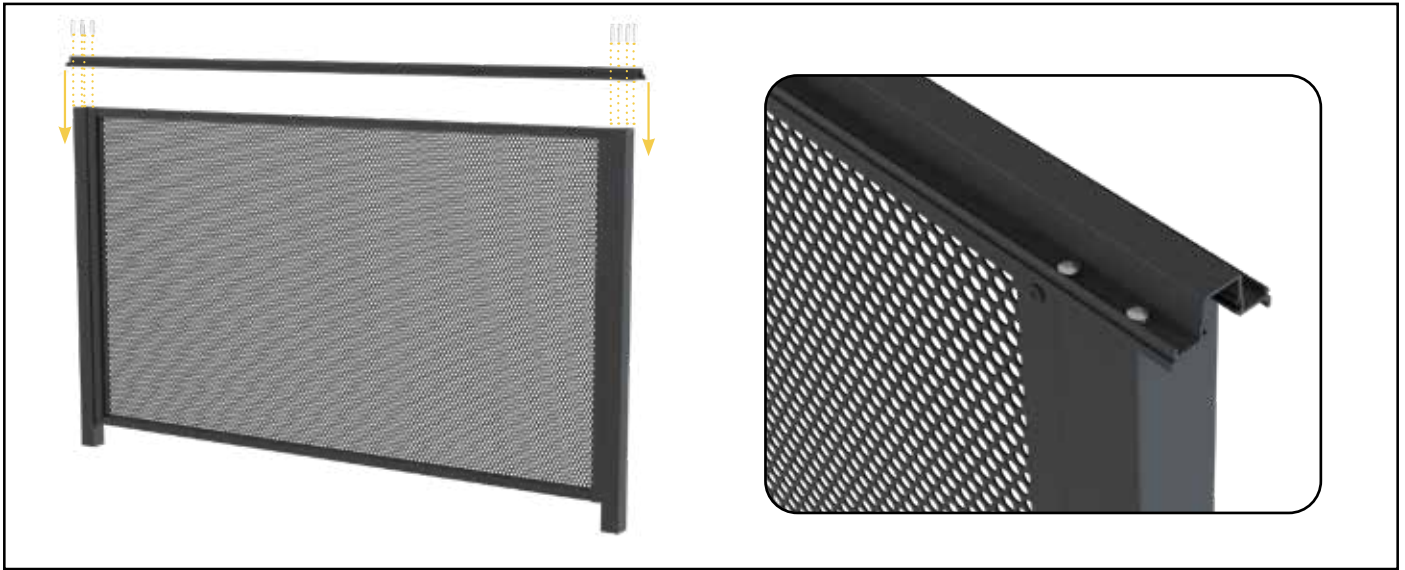

**9** Fix off undercapping rail to top of posts securing to each post with 12gx25mm panhead screws.

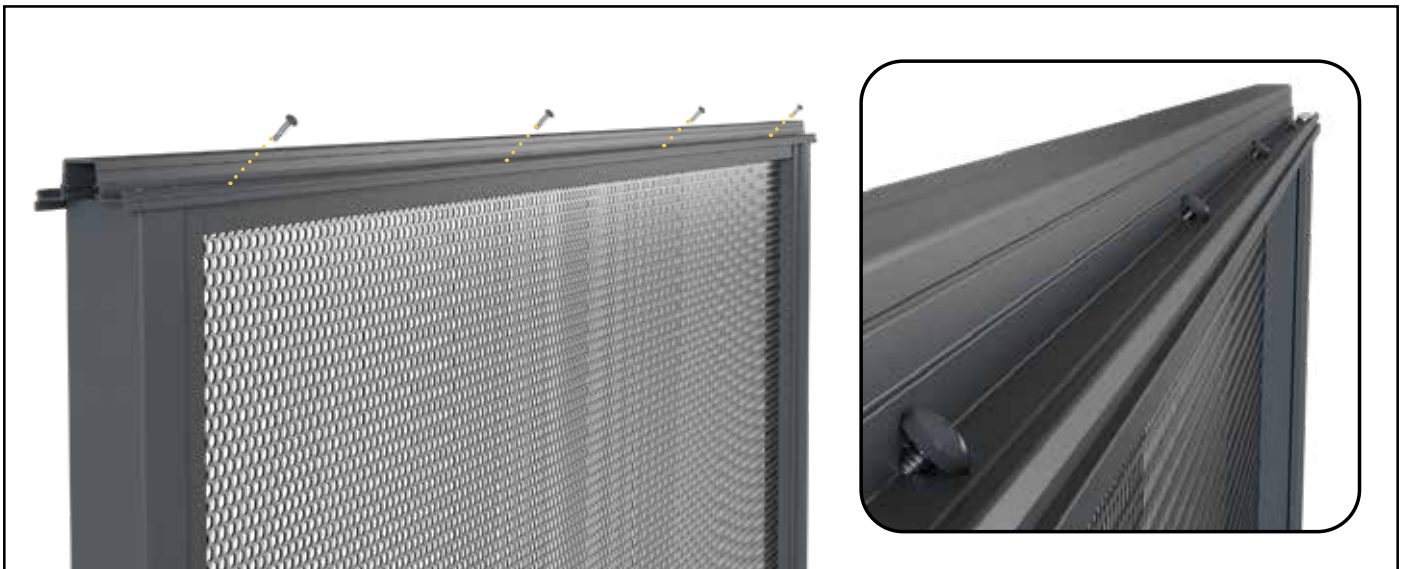

**10** Secure undercapping rail to frame with wafer screws going in through undercapping rail at a 45 degree angle, approx every 500mm.

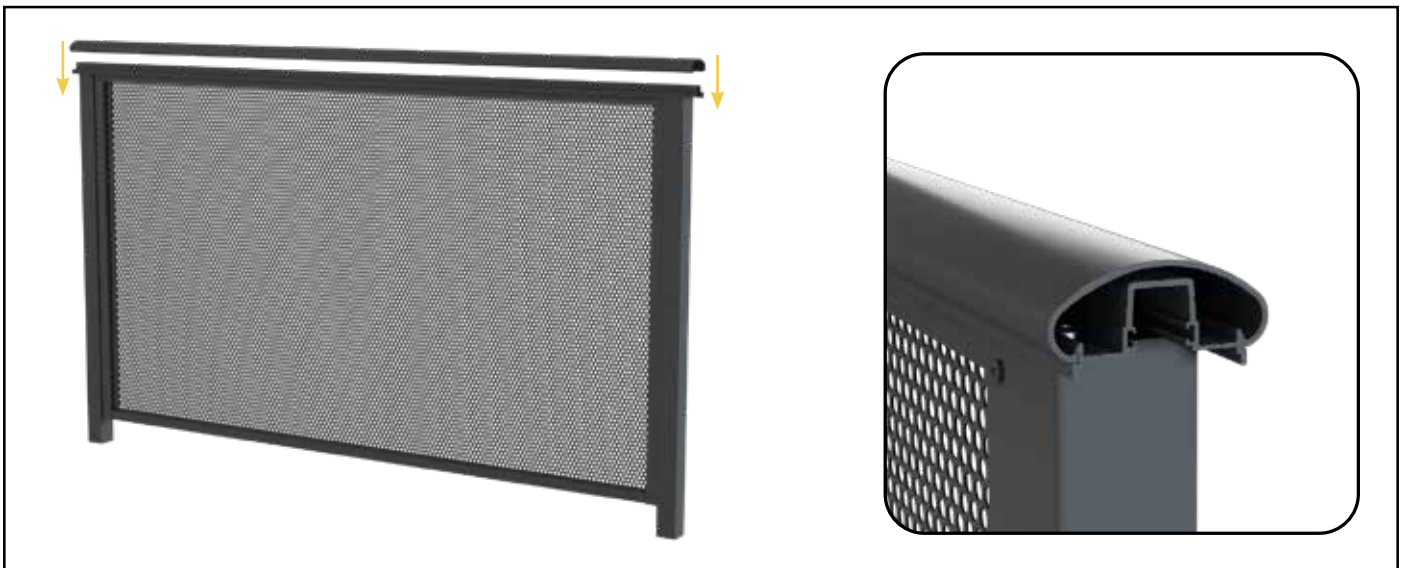

**11** Snap handrail onto undercapping rail.



# PERF BALUSTRADE ASSEMBLY OVERVIEW

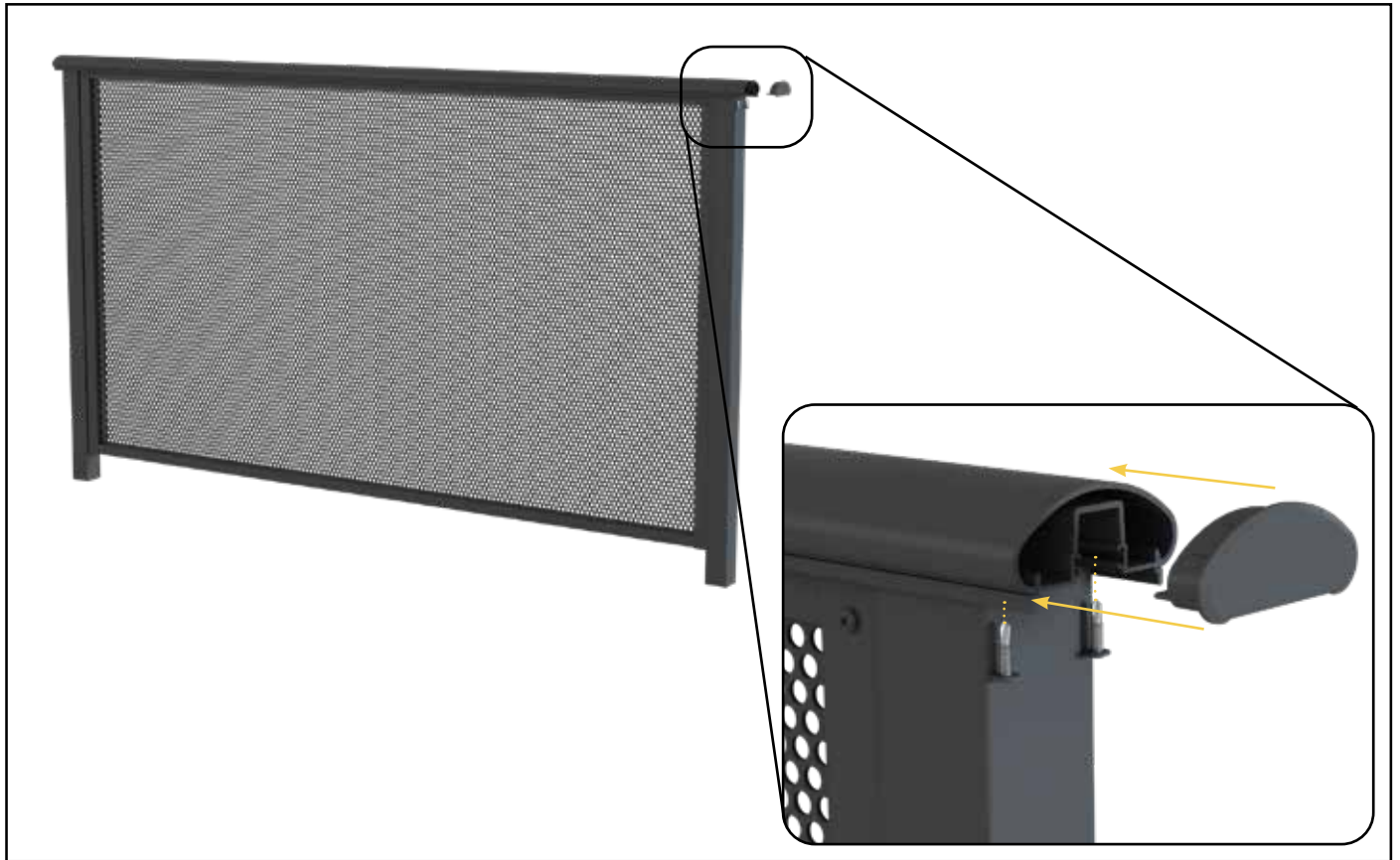

**12** If required, push end caps into end of handrail and secure on underside with 2 x wafer screws.



**13** If attaching handrail to wall, lever offset wall bracket over handrail and affix to wall using 2 x appropriate fixings (not provided) and one wafer screw through offset wall bracket into handrail.



# ASSEMBLY OVERVIEW – APPENDIX 1

## APPENDIX 1 / PANEL SIZE ADJUSTMENT FABRICATION OVERVIEW

### WIDTH AND HEIGHT ADJUSTMENT FOR OUTER FRAME

#### PANEL FRAMING CUTTING FORMULAS

2 x Horizontal Top/Bottom Rails = distance between posts minus 12mm

2 x Vertical side frames = Outer frame height of panel\*\* minus 51mm

2 x Vertical U Channels = Outer frame height of panel\*\*

\*\*assumes horizontal top and bottom installed onto infill sheet

### WIDTH AND HEIGHT ADJUSTMENT FOR INFILL PANEL

#### INFILL SHEET CUTTING FORMULA

SHEET WIDTH: Final outer frame width dimension minus 12mm

SHEET HEIGHT: Final outer frame height dimension minus 12mm

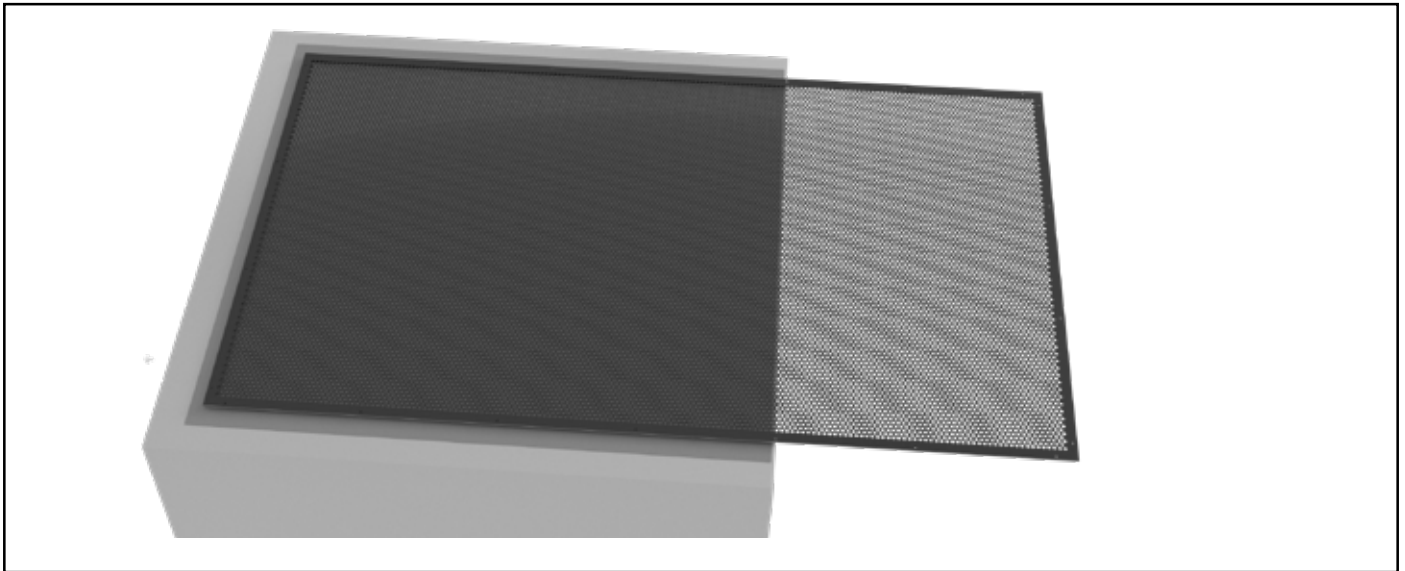

- 1 Lay the infill sheet on flat, padded surface, overhanging the off-cut.

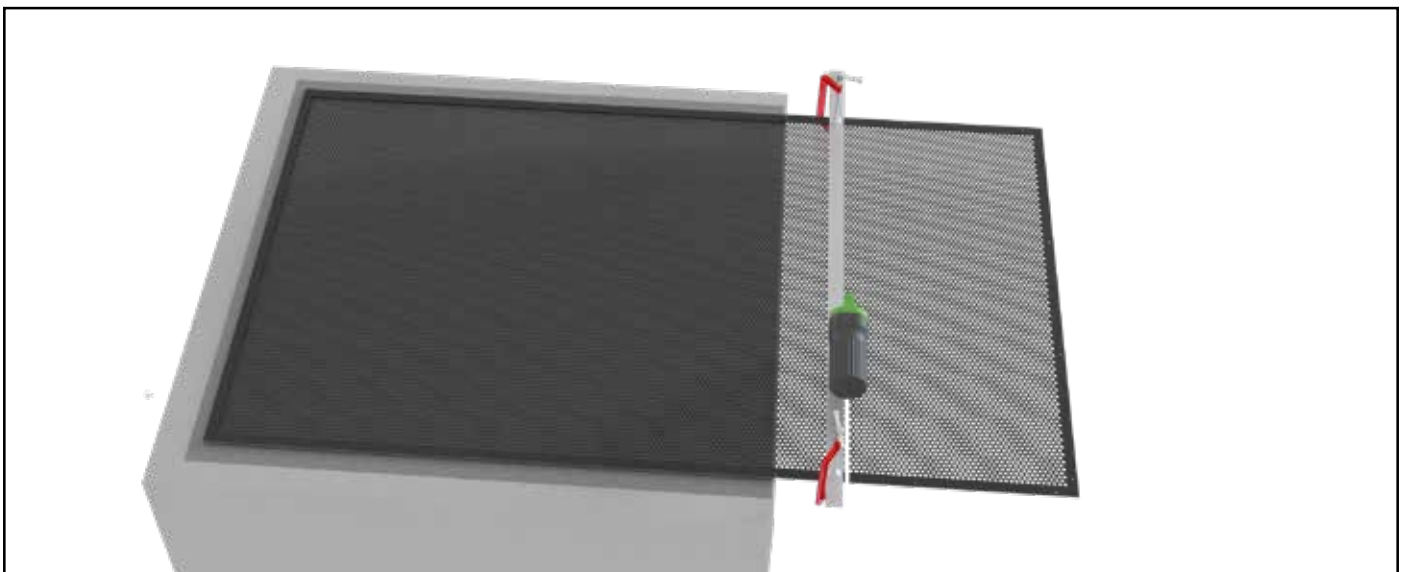

- 2 Using a clamped straight-edge as a guide, cut using a nibbler tool. (Infill sheet is 2.5mm thick aluminium – ensure nibbler suits cutting this specification.)

Once cut, file any sharp or protruding edges.

\*\*if height of panel requires adjusting, repeat steps 1 & 2 but for height





# ASSEMBLY OVERVIEW – APPENDIX 1

See Steps 1-6 of Assembly Guide, incorporating step 4 below.

**3** Assemble outer frame to infill sheet as per steps 1 to 6

## WIDTH AND HEIGHT ADJUSTMENT FOR HORIZONTAL AND VERTICAL FRAME

The fixing holes around the border of the infill sheet may be removed when adjusting width or height.

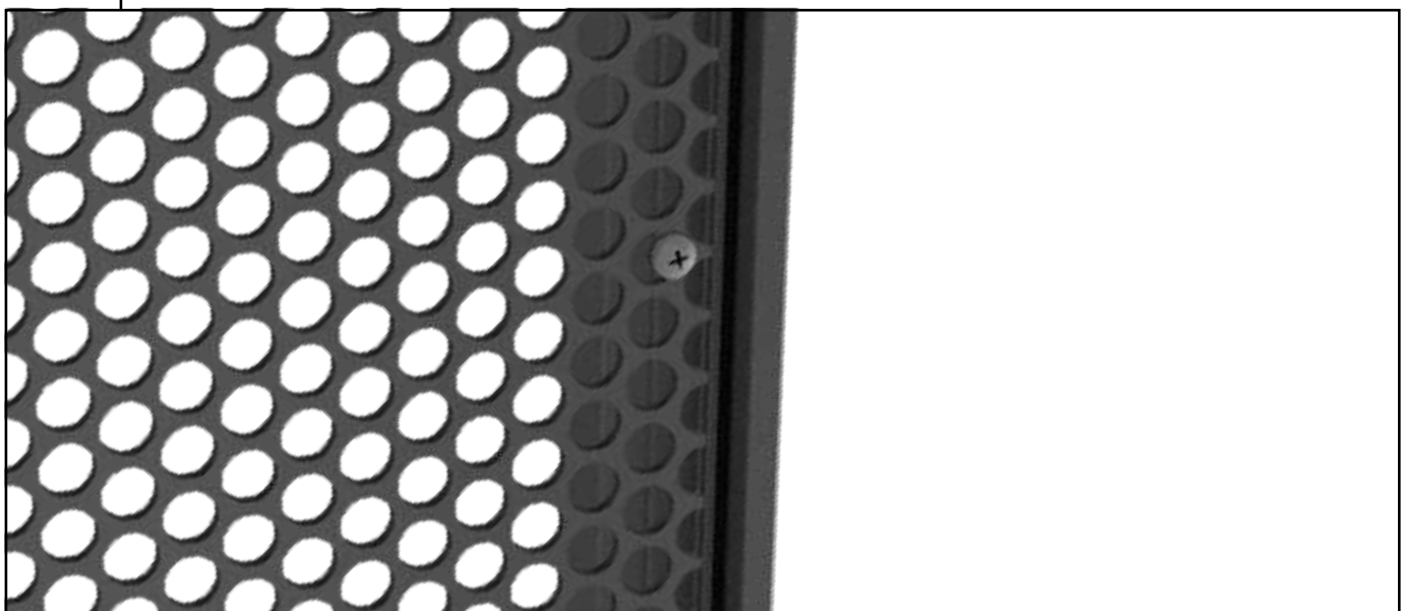
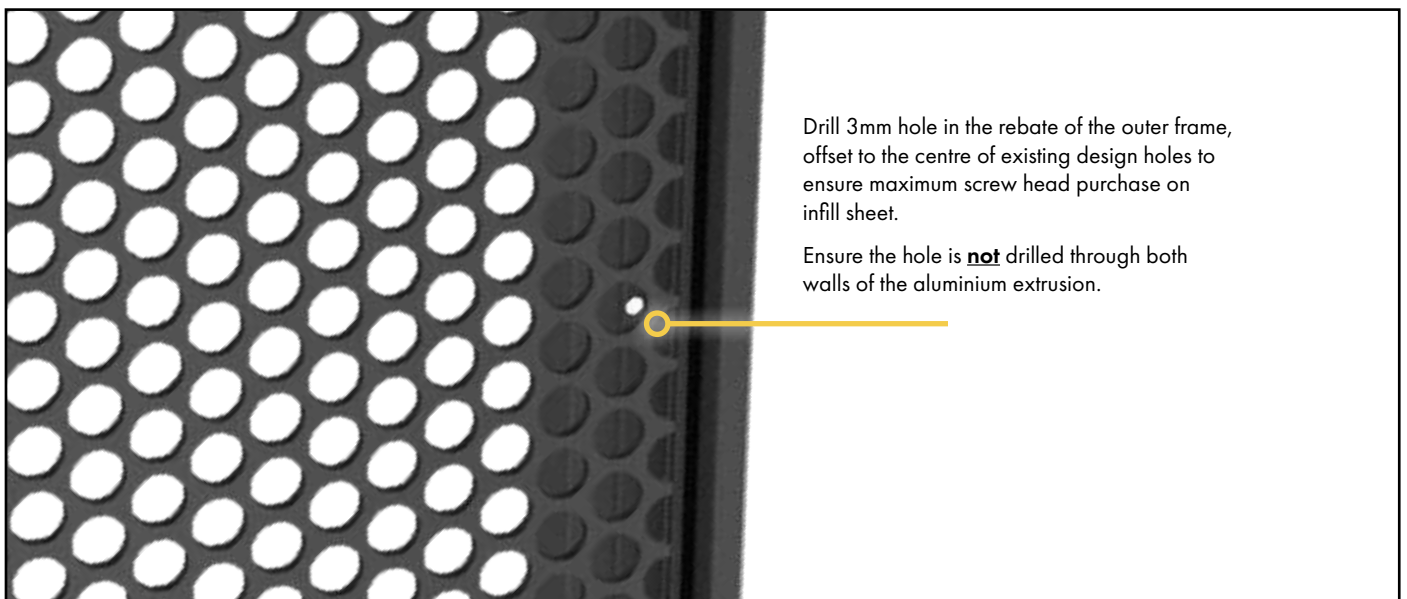

**4** Ensure holes/infill sheet fixings are approx 50mm from each corner and 400mm apart (applies to top/bottom/sides of panel).



# ASSEMBLY OVERVIEW – APPENDIX 1

---

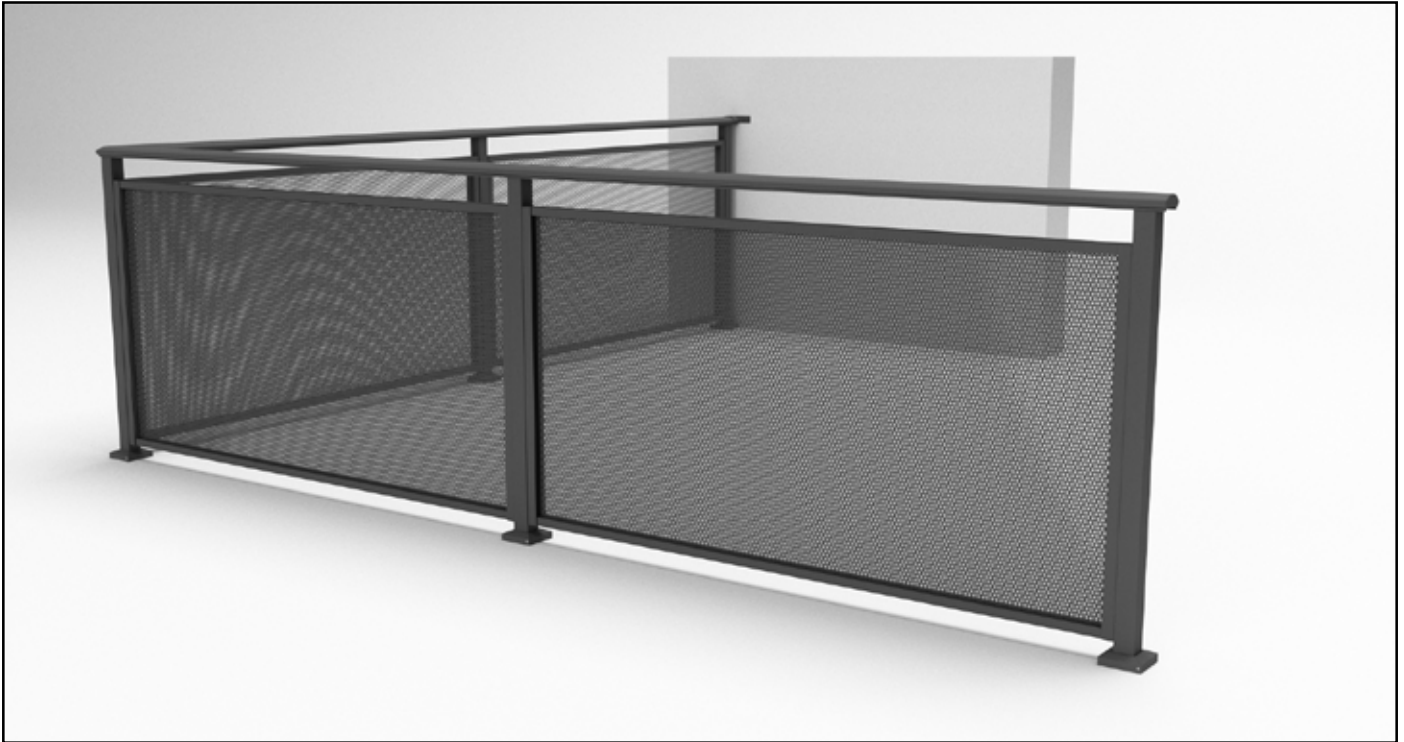

**NOTE**

For 3 rail configuration, height of panel can be adjusted as required to achieve desired look and spacing. U channel should be cut to same height as side frames, and snap in void infill installed to the channel in the undercapping of handrail.  
**NOTE:** Omit Step 10 from above assembly guide.





# EXTRAS

## Post plugs

4 PACK

Black or White finish

Order code: SS-POSTPLUG-4PK

SS-POSTPLUG-4PK-W

- Ø32mm outer top suits 25mm hole
- Ideal for covering hole in post when affixing post to wall with inner fixing
- Suits post wall thickness 1.5mm – 3.2mm

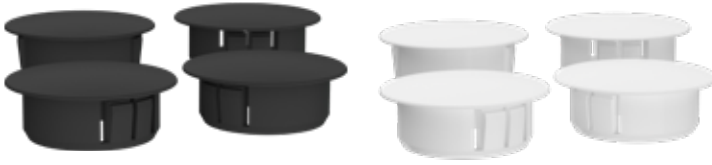

**1** Drill a 25mm diameter hole through front wall of post



**2** Drill rear wall of post with required diameter for fixing and then fix post to wall. Insert appropriate fixing into the wall for affixing post



**3** Once post is fixed to wall with appropriate fixing method, insert post plug to cover the post hole



**4** Repeat the process as required



### Polaris grout

- 10kg bag  
Order Code: **GROUT-POL-10KG**
- Non shrink grout
  - Rapid setting
  - Aggregate free



### Bostik HES grout

- 20kg bag  
Order Code: **GROUT-BOS**
- Non shrink grout
  - High early strength



### Sika HES grout

- 20kg bag  
Order Code: **GROUT-SIKA**
- Non shrink grout
  - High early strength



# DIAMOND REVOLUTION DRILL

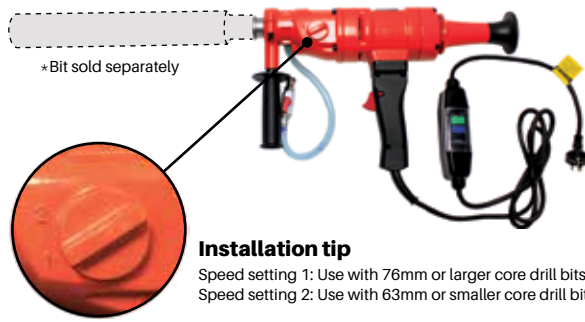

## Diamond revolution drill

Core drill

Order Code: REV-CD-2S

- 2 speed core drill - 1500W
- Comes with case, allen key, spare set of brushes and manual
- Safety switch
- Uses common size 1 1/4" UNC male thread for diamond core bits

### Technical data

Voltage: 240V  
 Rated frequency: 50-60Hz  
 Rated input power: 1500W  
 No load speed r/min: 2100/950  
 Weight: 8.8kg



## Diamond revolution stand

Suits diamond revolution core drill

Order Code: REV-STAND

- Steel and aluminium construction
- Height: 800mm
- Base: 330mm x 380mm
- Weight: 12.6kg



## Core drill template

Order Code: REV-TEMPLATE

- Assists with starting to core drill hole
- Stabilises the drill bit from jumping



## Spirit level for core drill

Order Code: REV-LEVEL

- Screws into core drill machine
- Assists with drilling accurate holes



## Splash guard/ water trap

Order Code: REV-GUARD



## Base for stand

Order Code: REV-BASE

- 550mm x 550mm overall dimensions

## Core drill bits Mild steel body & diamond impregnated crown tip



### 8mm mini core drill bit

Order Code: REV-BIT-08



### 10mm mini core drill bit

Order Code: REV-BIT-10



### 12mm mini core drill bit

Order Code: REV-BIT-12



### 14mm mini core drill bit

Order Code: REV-BIT-14



### 20mm mini core drill bit

Order Code: REV-BIT-20



### 53mm core drill bit

53mm x 450mm long  
Order Code: REV-BIT-53



### 63mm core drill bit

63mm x 450mm long  
Order Code: REV-BIT-63



### 76mm core drill bit

76mm x 450mm long  
Order Code: REV-BIT-76



### 83mm core drill bit

83mm x 450mm long  
Order Code: REV-BIT-83



### 89mm core drill bit

89mm x 450mm long  
Order Code: REV-BIT-89



---

Errors and omissions excepted. Measurements and drawings are provided as a guide only and should not be relied upon solely for installation purposes.

Product codes, products and prices may change at our discretion as systems are constantly reviewed and updated. Please contact us if you require clarification of product codes, pricing or product stocking.

Due to each installation situation being different, it is the installer's responsibility to seek engineering compliance and/or certification should it be required as part of a project, regulatory or statutory requirement.

Colours are indicative and should be used as a guide only.

All products should adhere to a suitable care and maintenance schedule.

© Copyright 2023. This catalogue is the copyright of GO and cannot be reproduced, copied or replicated without the prior written consent of GO. Such consent applies to images as well as text.

Aluminium Balustrade Systems catalogue Version 4

