

# THUMPER FAB BIG ASS UTV

## REAR VIEW MIRROR

SKU: RM12, RM17

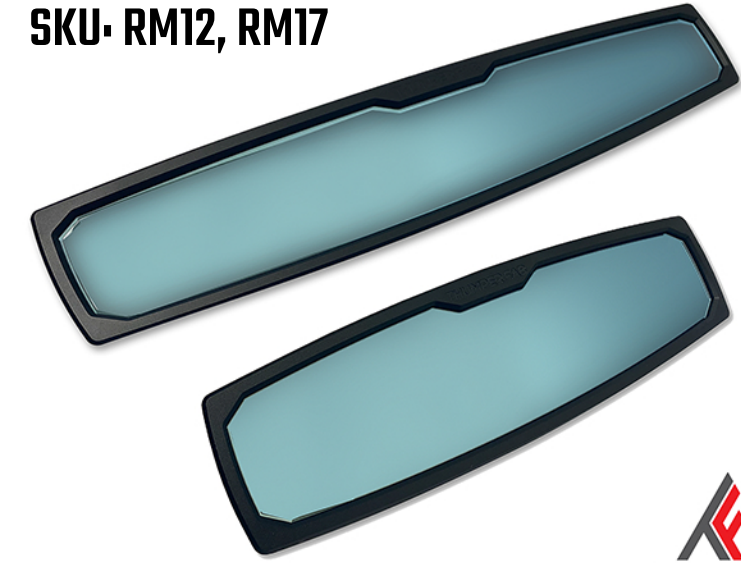

Please read instructions before beginning installation. Check the kit contents shown below. Be sure you have all needed parts and know where they go.

### PARTS

- Mirror Assembly x 1
- 
- Mirror Base Stand x 1
- 
- M5 Threaded Bolt x 2
- 
- Bolt Joint x 1
- 
- M8 Nut x 1
- 
- 1.75 Inch Round Tube Clamp
- 
- 2 Inch Round Tube Clamp
- 
- Black Plastic Gasket x 2
- 
- M4, M5, M6 Wrench x 1



### STEP 1

Assemble the Mirror with the Mirror Base Stand, the M5 Bolt, the Ball Joint and M8 Nut.

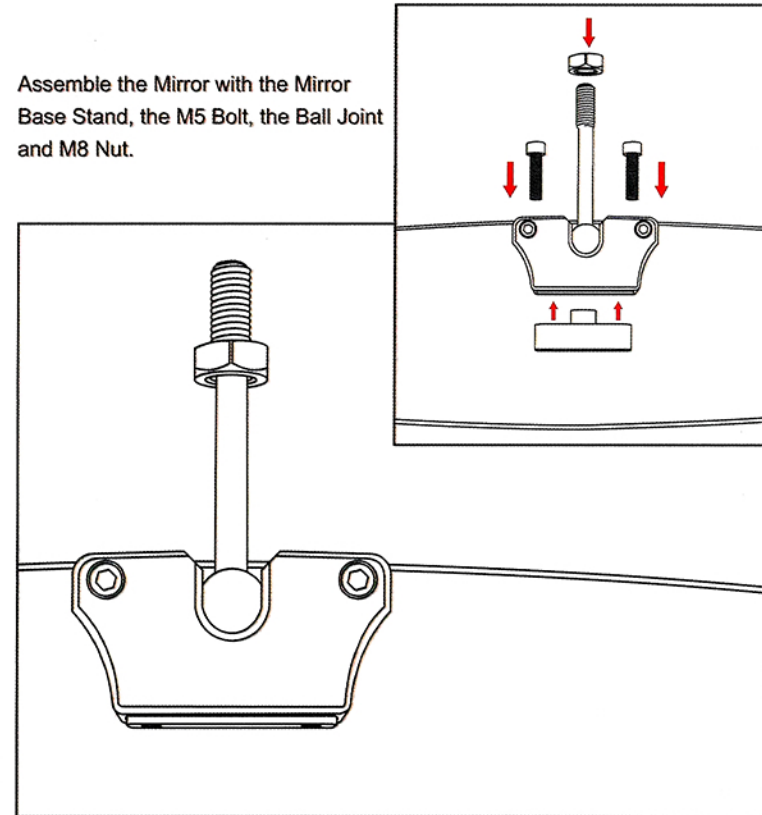

### STEP 2

Use these M5 Bolts and M5 Wrench to adjust tension on the ball joint. Clockwise turn will increase tension, Counter-clockwise will decrease tension.

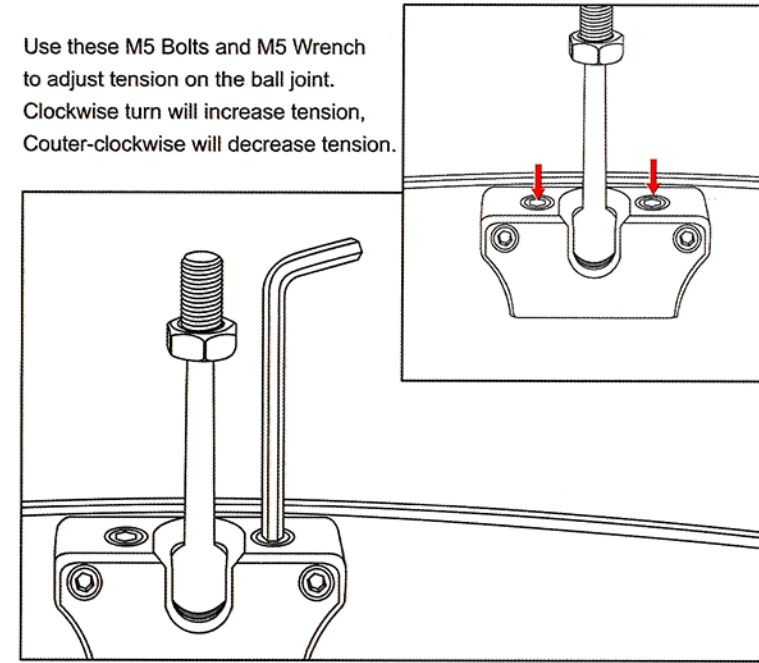

### STEP 3

There are two size of mount clamps included, 1.75 inch and 2 inch. Choose the one you need. Loosen the Tube Clamp with the M6 Wrench.

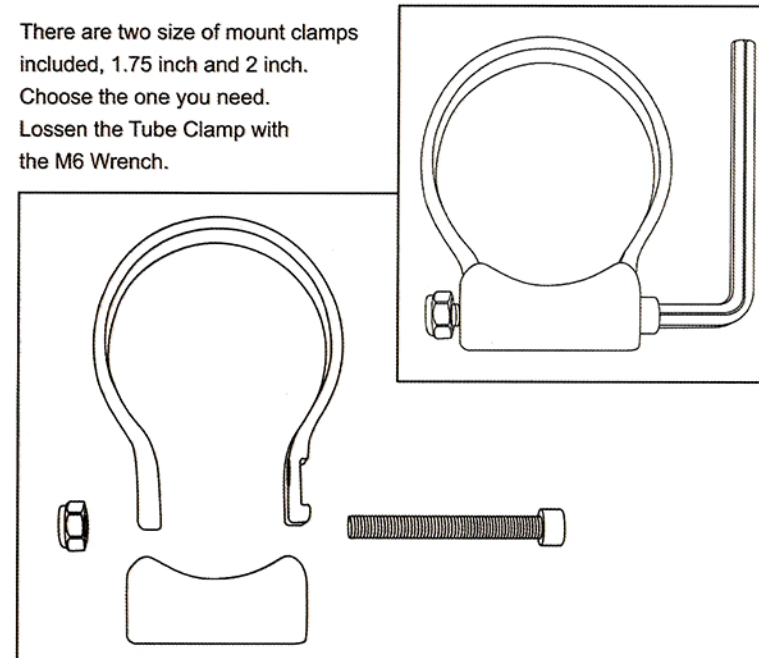

### STEP 4

Wrap the clamp halves around the tubing and install M6 Bolt and Nut to secure the 2 halves together. Use the Plastic Gasket if necessary.

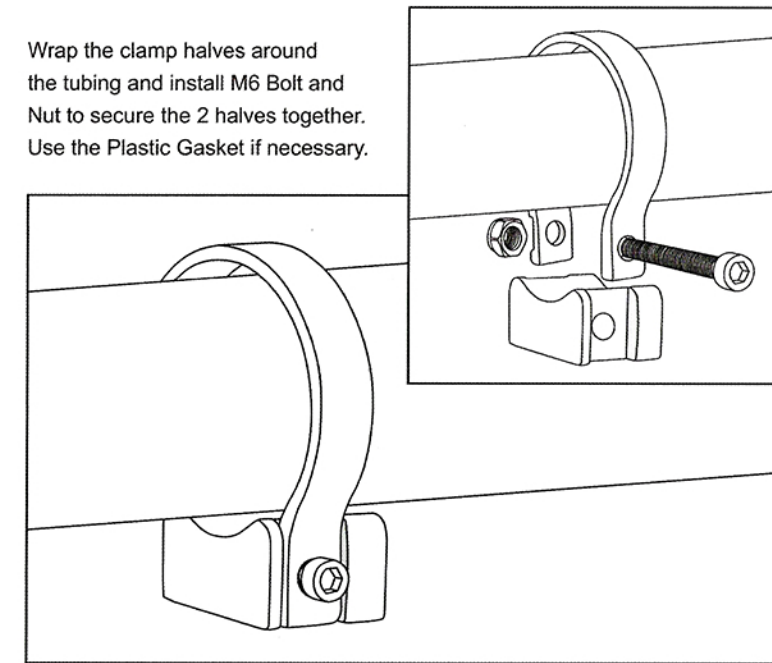

### STEP 5

Install the Ball Joint and the Mirror onto the clamp. Adjust as necessary.

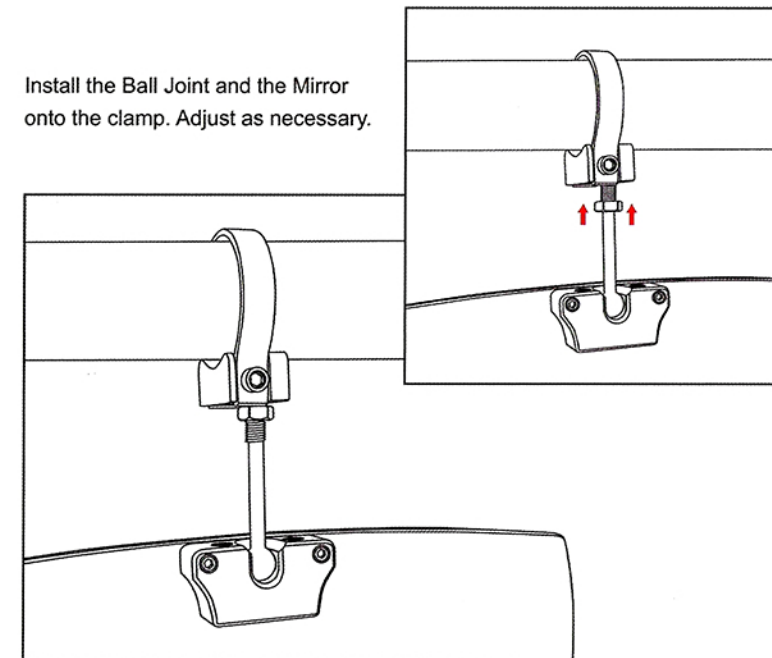

**Thumper Fab**  
5103 Elysian Fields Rd, Marshall, Tx 75672  
Customer Service: 903-472-0928

[www.thumperfab.com](http://www.thumperfab.com)