

TiALSport MVR Data Sheet

Within this sheet you'll find the technical data needed to provide for a clean installation and any future service required for your new TiALSport MVR Wastegate.

For any further technical questions, please email tech@tialsport.com

Configuration

Wastegates should be mounted as close to the collection point of the exhaust manifold as possible, with a flow angle no more acute than 90 degrees total.

- ▶ MV-Series wastegates utilize v-flange connections, with inlet and outlet differing in size.
- ▶ As with all TiALSport wastegates, the MV-Series use a replaceable valve seat, which must be installed between the inlet and manifold flange.
- ▶ The MV-Series can be used in both single- and dual-port configurations.
- ▶ Whenever possible, coolant flow should be connected to any MV-Series wastegate.
- ▶ The MVR is offered in an optional, air-assist-cooled version, the MVR-AR. For details, contact our team at tech@tialsport.com

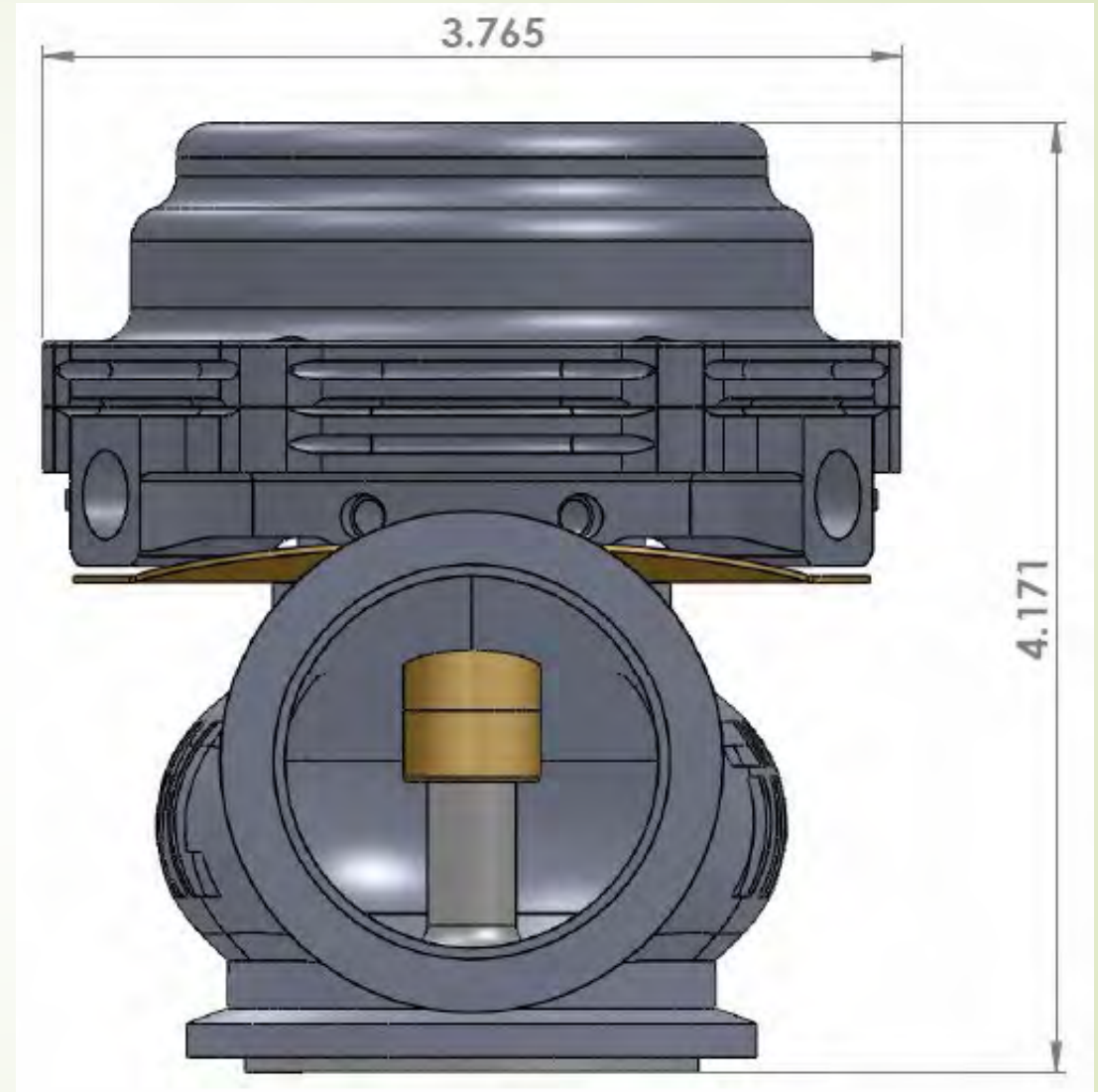

Connection

Various control strategies can be used, which may require different connection points. Below is a guide for most popular strategies.

- ▶ Single-port, non-regulated control strategies require that one lower housing port is connected directly to a boost-only source, and that the upper housing is vented to atmosphere.
- ▶ MV-Series units will have multiple port options. Unused ports should be plugged if not intentionally vented.
- ▶ Single-port, regulated control strategies will use the same connection method as non-regulated, except that the boost-only signal will be 'interrupted' by the control mechanism.
- ▶ Dual-port, regulated control strategies require a boost-only, non-regulated connection to the lower housing, and a boost-only, regulated connection to the upper housing. All other ports are to be plugged (when applicable).
- ▶ Coolant flow should always be routed through MV-Series units if at all possible, to ensure a long lifespan.
- ▶ External electronic controls should be connected as per the respective manufacturers' instructions.



MVR Spring Chart

The following information can help you to choose the correct spring group to suit your needs.

- ▶ Boost pressure ratings are based on an expectation of a 1:1 ratio of exhaust manifold (EMAP) to intake manifold (MAP) values.
- ▶ Variances in this ratio will skew the values in the opposite direction of the variance.
- ▶ We recommend beginning the tuning process with a spring group that represents ~50-60% of your desired peak boost threshold, then using the external control strategy to raise the boost pressure.
- ▶ If no external control is used, choose the spring that represents your desired peak threshold.
- ▶ These values **DO NOT** represent test values, which are on the next page.

TiALSport MVR Spring Pressure Chart

Pressure- Bar	Pressure- PSI	P/N	Description/Color	O.D., (in)
0.3	4.35	001951	Plain	2.32
0.6	8.7	001995	Black	1.88
0.5	7.25	001988	White	1.88
0.6	8.7	001997	Blue	1.5
0.4	5.8	001994	Red	1.48
0.5	7.25	001975	Yellow	1.15
0.3	4.35	001983	Green	1.13

Static Testing

Static (bench) testing should be performed any time the unit is disassembled and the instructions below should be followed carefully.

- ▶ The static testing values represent the rate at which the WG will just begin to open. They **DO NOT** represent the boost pressure expectation.
- ▶ To test a WG, use a regulated source of compressed air, limited to 2bar (30psi) maximum, and note the pressure rating at the initial point of lift only. Compare this to test table **ONLY**..
- ▶ It is **perfectly normal** for air to escape from the lower valve casting during this testing.
- ▶ The opening rate can be altered by simply changing springs.

PART #	COLOR	SIZE/POSITION	TEST VALUE-PSI
001995	Black	Large/3	11.8
001988	White	Large/3	9.9
001997	Blue	Medium/2	11.0
001994	Red	Medium/2	7.8
001974	Yellow	Small/1	9.5
001983	Green	Small/1	5.3
001951	Plain	Outer/4	5.9

MVR FAQ

- ▶ **What spring(s) should I use for (insert value here) boost pressure?**
- ▶ *This varies greatly by application, so we suggest beginning the tuning session with a spring group that represents 50-60% of your desired peak boost threshold, then, for non-regulated strategies, testing, then adjusting the spring pack to hit your target. For regulated strategies, increase the boost pressure using the external control strategy and adjust the spring pack so that you can achieve good resolution across the desired range.*
- ▶ **Can I use my stock boost control solenoid for my TiALSport wastegate?**
- ▶ *Yes, but it's recommended to use a higher-flowing solenoid, such as the popular MAC-type air valves. They typically allow the use of larger-diameter hoses and are also a bit more robust.*
- ▶ **Can I use my manual boost controller?**
- ▶ *Yes, you sure can. Just keep in mind that MBC's are unintelligent, and cannot compensate for temperature or air density changes, nor can they adjust for differing engine loads. If possible, use an MBC in a dual-port strategy for best results, but follow the manufacturers' instructions carefully.*
- ▶ **Can I use CO2 to control my TiALSport wastegate?**
- ▶ *Yes, but unless you're using an F46D, V50D or V60D, expect a shortened lifespan from the diaphragm, and reduced control resolution. Only the "D" models are designed specifically for high-pressure, top-down control.*
- ▶ **Why does my wastegate leak air through the discharge when I perform a boost leak test?**
- ▶ *Most external wastegates do not use a positive seal structure on the valve stem/guide area, and this type of static testing will always result in air passing through that clearance. Don't worry, though, it's perfectly normal. If you want to isolate any potential leakage, disconnect and cap off the wastegate control lines for boost leak testing, then use the Static Testing instructions in the previous page to confirm that the unit is functioning properly.*
- ▶ **What's the deal with the MVR and MVR-AR?**
- ▶ *The MVR, when connected to coolant flow, will resist heat-based failures for incredibly long periods of time. But in applications that simply don't have coolant flow (we're looking at you, Porsche), or where coolant flow cannot be routed, or where radiant heat affects the actuator from the outside-in, MVR-AR will provide air-assist cooling with a unique finned heat sink design. Yes, they cost more, and no, you can't get every color, but when you need them, they're ready for you.*

Exploded View and Parts List

- The MV-Series is sold our signature, solid SS v-clamps, 304SS v-flanges, coolant and air fittings and all spring options in the box.
- A 6061AL inlet flange is offered for the MVR for supercharger bypass use.
- All service parts listed are available as loose items and can be found at tialsport-outlet.com

