

TiALSport F38 Data Sheet

Within this sheet you'll find the technical data needed to provide for a clean installation and any future service required for your new TiALSport F38 Wastegate.

For any further technical questions, please email tech@tialsport.com

Configuration

Wastegates should be mounted as close to the collection point of the exhaust manifold as possible, with a flow angle no more acute than 90 degrees total.

- The F38 uses a common 2-bolt flanged connection, identical at the inlet and outlet.
- As with all TiALSport wastegates, the F38 uses a replaceable valve seat, which must be installed between the inlet and manifold flange.
- The F38 should be installed with the (supplied) SS single-sheet gaskets only. Fiber or 'fire-ring' type gaskets may cause leaks.
- The F38 can be used in both single- and dual-port configurations.
- The lower air signal port can be rotated into the desired position by disassembling the unit and utilizing the lower housing not and locking screw.

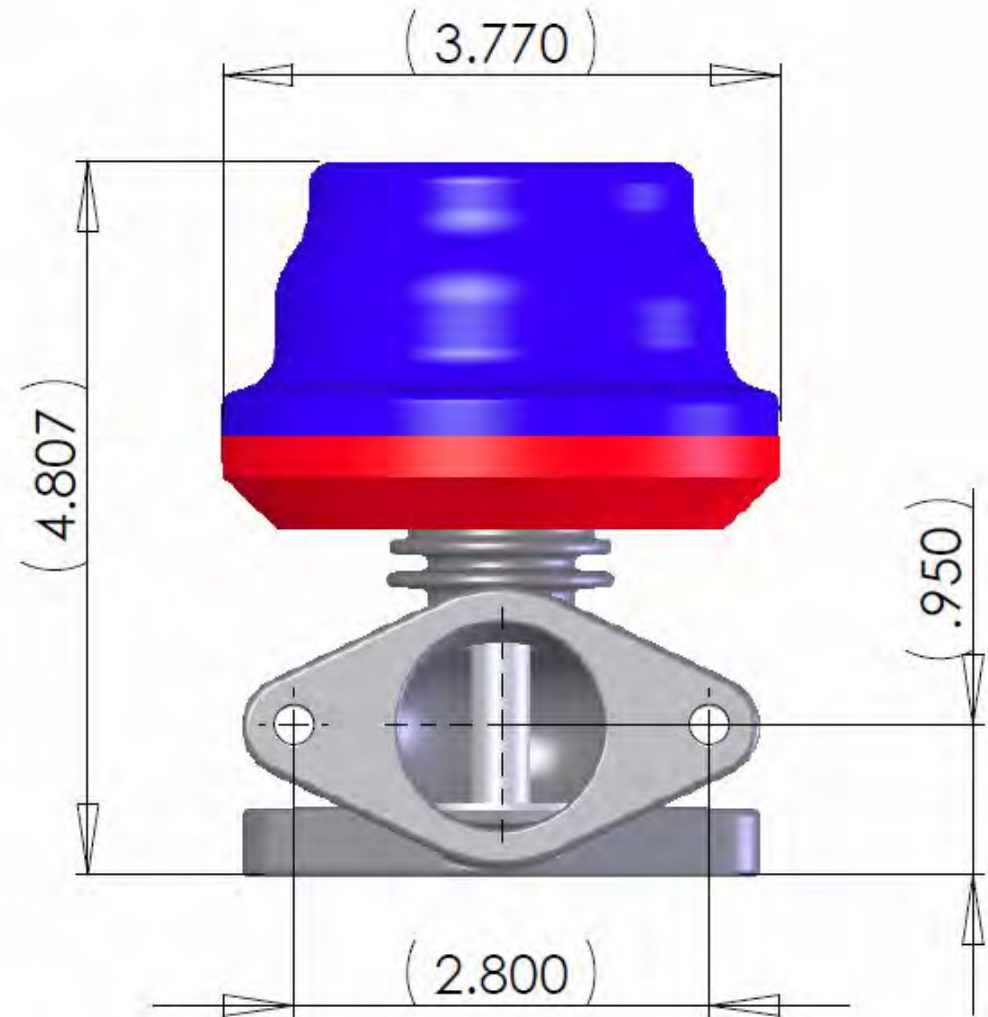

Connection

Various control strategies can be used, which may require different connection points. Below is a guide for most popular strategies.

- ▶ Single-port, non-regulated control strategies require that one lower housing port is connected directly to a boost-only source, and that the upper housing is vented to atmosphere.
- ▶ MV-Series units will have multiple port options. Unused ports should be plugged if not intentionally vented.
- ▶ Single-port, regulated control strategies will use the same connection method as non-regulated, except that the boost-only signal will be 'interrupted' by the control mechanism.
- ▶ Dual-port, regulated control strategies require a boost-only, non-regulated connection to the lower housing, and a boost-only, regulated connection to the upper housing. All other ports are to be plugged (when applicable).
- ▶ Coolant flow should always be routed through MV-Series units if at all possible, to ensure a long lifespan.
- ▶ External electronic controls should be connected as per the respective manufacturers' instructions.

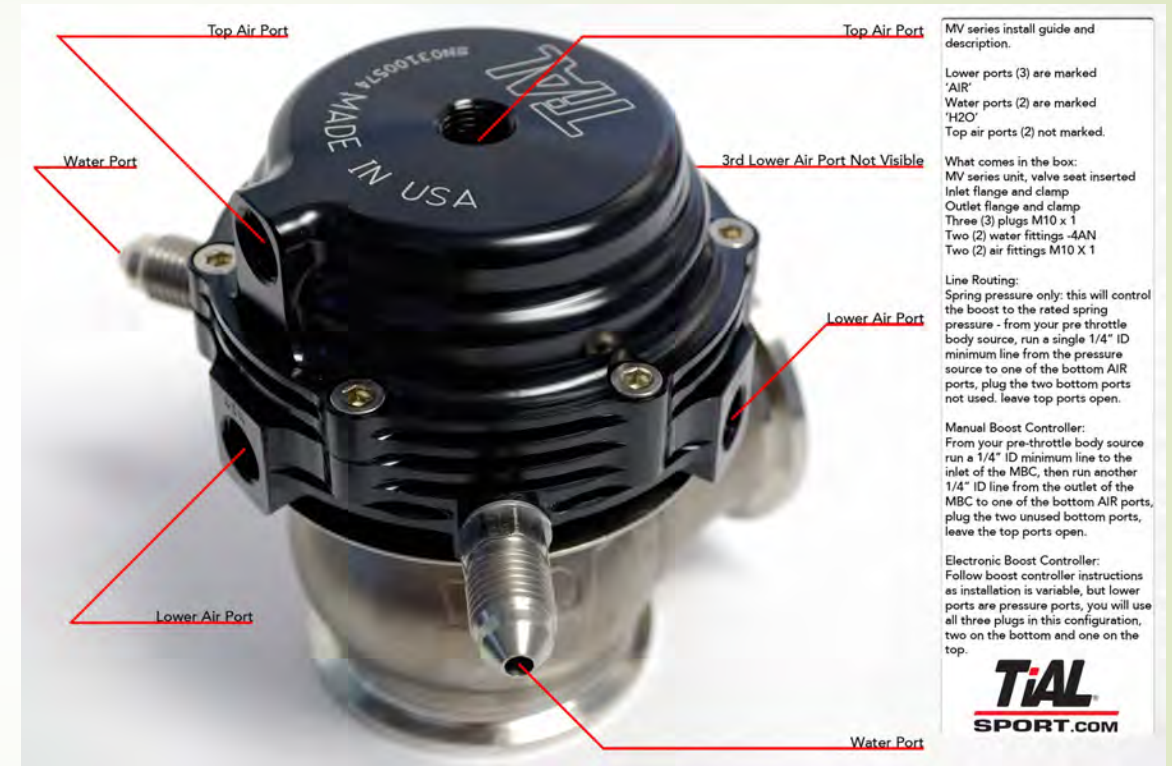

F38 Spring Chart

The following information can help you to choose the correct spring group to suit your needs.

- ▶ Boost pressure ratings are based on an expectation of a 1:1 ratio of exhaust manifold (EMAP) to intake manifold (MAP) values.
- ▶ Variances in this ratio will skew the values in the opposite direction of the variance.
- ▶ We recommend beginning the tuning process with a spring group that represents ~50-60% of your desired peak boost threshold, then using the external control strategy to raise the boost pressure.
- ▶ If no external control is used, choose the spring that represents your desired peak threshold.
- ▶ These values **DO NOT** represent test values, which are on the next page.

TiALSport F38 Spring Pressure Chart

Pressure- Bar	Pressure- PSI	P/N	Description/Color	O.D., (in)
0.25	3.6	002192	Small Yellow	1.875
0.4	5.8	002190	Small Red	1.875
0.5	7.25	002189	Small Green	1.875
0.6	8.7	002188	Small Blue	1.875
0.7	10.15	001841	Large Yellow	2.36
0.8	11.6	001840	Large Red	2.36
0.9	13	001839	Large Green	2.36
1	14.5	001838	Large Blue	2.36

Static Testing

Static (bench) testing should be performed any time the unit is disassembled and the instructions below should be followed carefully.

- ▶ The static testing values represent the rate at which the WG will just begin to open. They **DO NOT** represent the boost pressure expectation.
- ▶ To test a WG, use a regulated source of compressed air, limited to 2bar (30psi) maximum, and note the pressure rating at the initial point of lift only. Compare this to test table **ONLY**..
- ▶ It is **perfectly normal** for air to escape from the lower valve casting during this testing.
- ▶ The opening rate can be altered by simply changing springs.

PART #	COLOR	SIZE/POSITION	TEST VALUE-PSI
001838	Blue	Large/Outer	16.5
001839	Green	Large/Outer	14.7
001840	Red	Large/Outer	13
001841	Yellow	Large/Outer	11.3
002188	Blue	Small/Inner	9.5
002189	Green	Small/Inner	7.8
002191	Red	Small/Inner	5.9
001841	Yellow	Small/Inner	4.3
4869	Black	Bonus/Inner	N/A
4868	White	Bonus/Inner	N/A



F38 FAQ



- ▶ **What spring(s) should I use for (insert value here) boost pressure?**
- ▶ *This varies greatly by application, so we suggest beginning the tuning session with a spring group that represents 50-60% of your desired peak boost threshold, then, for non-regulated strategies, testing, then adjusting the spring pack to hit your target. For regulated strategies, increase the boost pressure using the external control strategy and adjust the spring pack so that you can achieve good resolution across the desired range.*
- ▶ **Can I use my stock boost control solenoid for my TiALSport wastegate?**
- ▶ *Yes, but it's recommended to use a higher-flowing solenoid, such as the popular MAC-type air valves. They typically allow the use of larger-diameter hoses and are also a bit more robust.*
- ▶ **Can I use my manual boost controller?**
- ▶ *Yes, you sure can. Just keep in mind that MBC's are unintelligent, and cannot compensate for temperature or air density changes, nor can they adjust for differing engine loads. If possible, use an MBC in a dual-port strategy for best results, but follow the manufacturers' instructions carefully.*
- ▶ **Can I use CO2 to control my TiALSport wastegate?**
- ▶ *Yes, but unless you're using an F46D, V50D or V60D, expect a shortened lifespan from the diaphragm, and reduced control resolution. Only the "D" models are designed specifically for high-pressure, top-down control.*
- ▶ **Why does my wastegate leak air through the discharge when I perform a boost leak test?**
- ▶ *Most external wastegates do not use a positive seal structure on the valve stem/guide area, and this type of static testing will always result in air passing through that clearance. Don't worry, though, it's perfectly normal. If you want to isolate any potential leakage, disconnect and cap off the wastegate control lines for boost leak testing, then use the Static Testing instructions in the previous page to confirm that the unit is functioning properly.*

Exploded View and Parts List

- The F38 is sold with gaskets and air fittings only. Flanges are not included
- Flanges are offered in 304SS and 1018MS.
- All service parts listed are available as loose items and can be found at tialsport-outlet.com

