

Please read this manual carefully before installation and keep it for future reference.

Owner & Installation Manual



MRCOOL®

COMFORT MADE SIMPLE

DIY® Multi-Zone

Please read this manual carefully before installation and keep it for future reference.

V03.06.2020

!	Safety Precautions	
	Warnings	3
	Cautions	4
1	Parts Overview	
	Parts Diagram	5
	Display Window	7
	Accessories	8
2	Operating Instructions	
	Operating Temperature	10
	Manual Operation	10
	Airflow Directional Control	11
	How the A/C & Heat Pump Work	12
	Special Functions	13
3	Care and Maintenance	
	Before Maintenance	14
	Cleaning the Unit	14
	Cleaning the Air Filter(s)	14
	Preparation for Extended Non-Operation	15
	Pre-Season Inspection	15
4	Installation Diagram	16

DISCLAIMER: Installing the MRCOOL DIY multi-zone does not require specialized tools or training. It does require basic technical skills. You are assuming the risk by handling materials containing refrigerants under pressure including that if not handled properly, refrigerant can cause bodily injury. If you do not feel comfortable conducting this installation process yourself, we recommend you retain the services of a qualified HVAC professional.

5 Indoor Unit Installation17

1. Installation location.....17
2. Attach mounting plate to wall.....18
3. Drill wall hole for connective piping.....18
4. Prepare refrigerant piping20
5. Connect refrigerant piping21
6. Connect drain hose.....23
7. Wrap piping and cables.....24
8. Mount indoor unit.....24

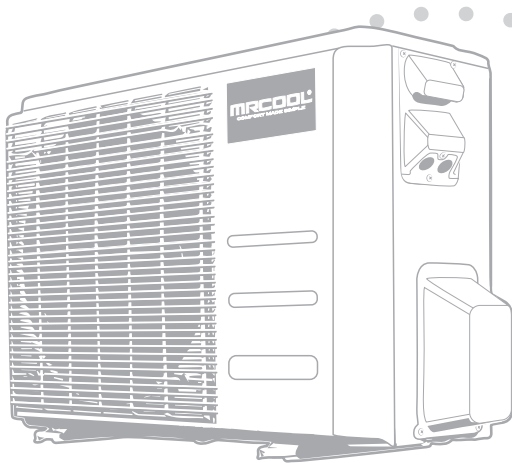

6 Outdoor Unit Installation 25

1. Installation location25
2. Install drain joint26
3. Anchor outdoor unit 27

7 Refrigerant Piping Connections.....29

8 Electrical Connections33

9 Electrical and Gas Leak Checks.....36

10 Test Run.....37

11 Troubleshooting.....39

12 EU Disposal Guidelines.....43

Safety Precautions



Read Before Using

Incorrect usage may cause serious damage or injury.

The seriousness of potential damage or injuries is classified as either a **WARNING** or **CAUTION**.



WARNING

This symbol indicates ignoring instructions may cause death or serious injury.



CAUTION

This symbol indicates that ignoring instructions may cause moderate injury to your person, damage to your unit, or other property.



This symbol indicates that you should **NEVER** perform the indicated action.



WARNING

Installing the MRCOOL DIY multi-zone does not require specialized tools or training. It does require basic technical skills. You are assuming the risk by handling materials containing refrigerants under pressure including that if not handled properly, refrigerant can cause bodily injury. If you do not feel comfortable conducting this installation process yourself, we recommend you retain the services of a qualified HVAC professional.

- ⊘ **DO NOT** share the electrical circuit with other appliances. Improper or insufficient power supply can cause fire or electrical shock.
- ⊘ When connecting refrigerant piping, **DO NOT** let substances or gases other than the refrigerant enter the unit. The presence of other gases or substances will lower the unit's capacity, and may cause abnormally high pressure in the operation cycle. This may cause explosion and injury.
- ⊘ **DO NOT** allow children to play with the air conditioner. Children should be supervised around the unit at all times.
 1. Installation must be performed according to installation instructions. Improper installation may cause water leakage, electrical shock, fire, or may void the warranty.
 2. In North America, service or repair must be performed in accordance with the requirement of NEC and CEC (by authorized personnel or authority having jurisdiction only.) Contact an authorized service technician for repair or maintenance of the unit.
 3. Only use the included accessories and specified parts for installation. Using non-standard parts can cause water leakage, electrical shock, or fire and may cause the unit to fail.
 4. Install the unit in a firm location that can support the unit's weight. If the installation location cannot support the weight, or the installation is performed improperly, the unit may fall and cause serious injury and/or damage.
 5. For all electrical work, follow all appropriate wiring standards, regulations, and the Installation Manual.
 6. You must use an independent circuit to supply power. Do not connect other appliances to the same circuit. Insufficient electrical capacity or defects in electrical work can cause electrical shock or fire.

Safety Precautions

WARNING

7. For all electrical work, fuse the specified cables. Connect cables tightly, and clamp them securely to prevent external forces from damaging the terminal. Improper electrical connections may overheat, causing fire and/or electrical shock.
8. If connecting power to fixed wiring, the following is required: 1. An all-pole disconnection device (which has at least 3mm clearances in all poles and has a leakage current that may exceed 10mA), 2. A residual current device (which has a rated residual operating current not exceeding 30mA) and 3. A disconnection box, must be incorporated in the fixed wiring that is in accordance with the wiring rules as shown in the Electrical Connections section of this manual.
9. In certain functional environments, such as kitchens, server rooms, etc., the use of specially designed air-conditioning units is highly recommended. If the supply cord is damaged, it must be replaced by the manufacturer, its service agent or similarly qualified persons in order to avoid a hazard.
10. This appliance can be used by children aged 8 years and above and persons with reduced physical, sensory or mental capabilities or lack of experience and knowledge if they have been given supervision or instruction concerning use of the appliance in a safe way and understand the hazards involved. Children should not play with the appliance. Cleaning and user maintenance should not be made by children without supervision.

CAUTION

- ⊘ **DO NOT** install the unit in a location that may be exposed to combustible gases. If combustible gas accumulates around the unit, it may cause fire.
 - ⊘ **DO NOT** operate your air conditioner in a wet room such as a bathroom or laundry room. Too much exposure to water may cause electrical components to short circuit.
 - ⊘ **DO NOT** operate the air conditioner with wet hands. This may cause electrical shock.
 - ⊘ **DO NOT** climb onto or place objects on top of the outdoor unit.
1. The product must be properly grounded during installation, or electrical shock may occur.
 2. Install drainage piping according to the instructions in this manual. Improper drainage may cause water damage to your home and property.

Note about Flourinated Gasses:

1. This air-conditioning unit contains flourinated gases.
2. For specific information on the type of gas and the amount, please refer to the relevant label on the unit itself.
3. Service, maintenance, and repair of this unit must be performed by a certified technician.
4. Product uninstallation and recycling must be performed by a certified technician.
5. If the system has a leak-detection system installed, it should be checked for leaks at least every 12 months.
6. Keep a record of all leak checks for the lifetime of the unit.

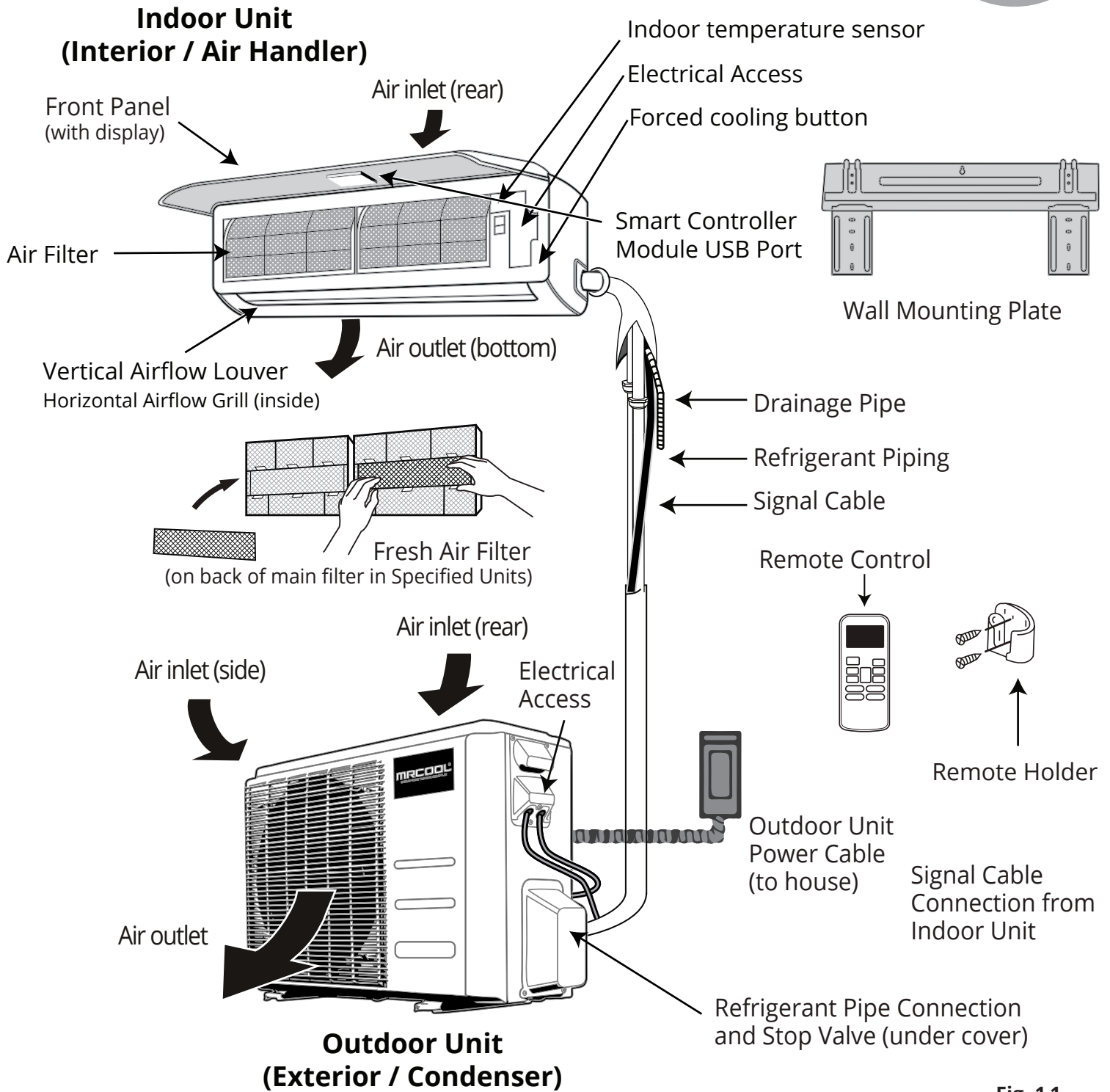

Fig. 1.1

NOTE ON ILLUSTRATIONS

Illustrations in this manual are for explanatory purposes. The actual shape of your unit may vary.

Indoor unit

1. Panel frame
2. Rear air intake grill
3. Front panel
4. Air purifying filter & Air filter (behind)
5. Horizontal louver
6. LCD display window
7. Vertical louver
8. Manual control button (behind)
9. Remote controller holder

Outdoor unit

10. Drain hose, refrigerant connecting pipe
11. Connective cable
12. Stop valve
13. Fan hood

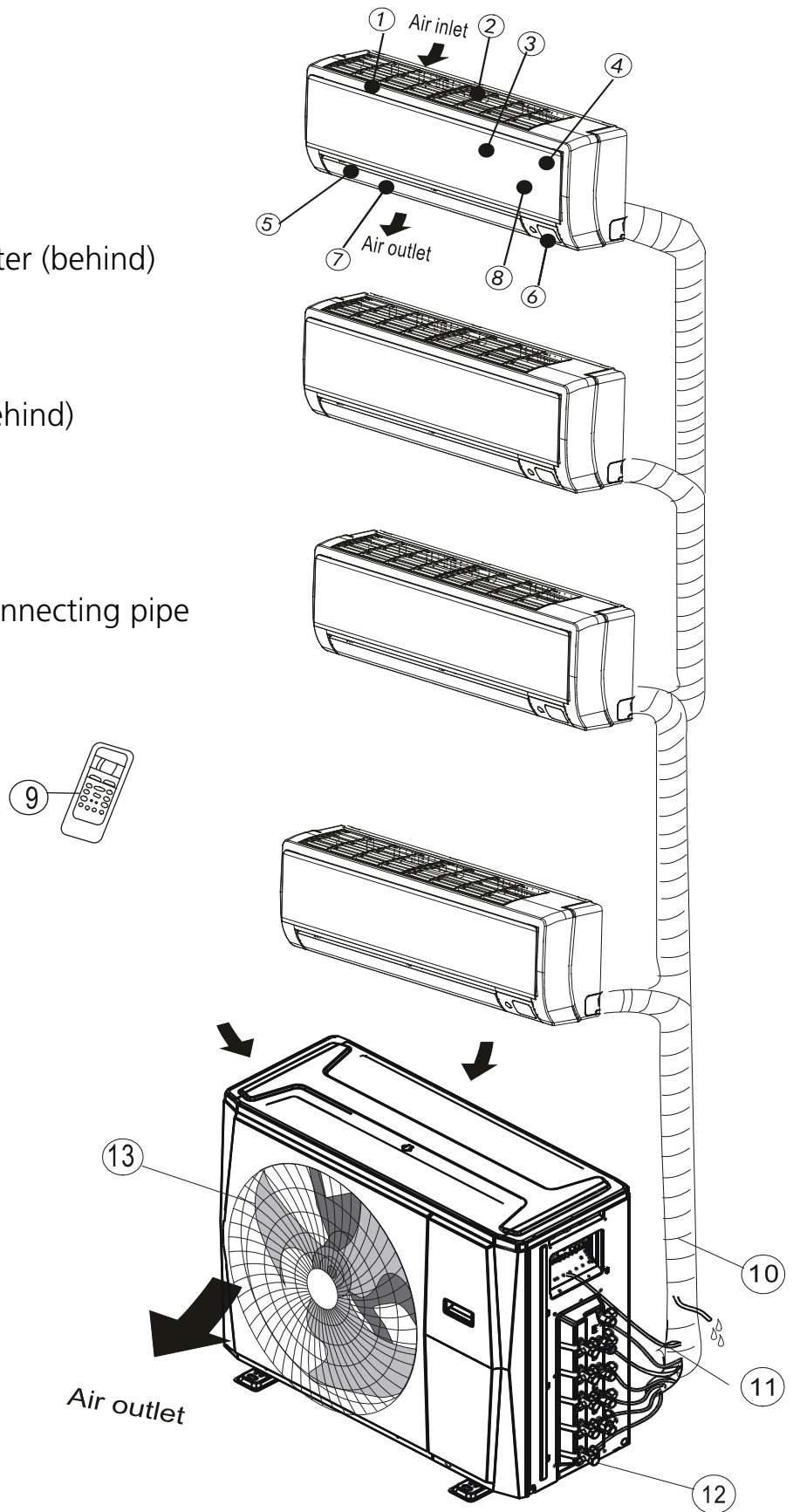

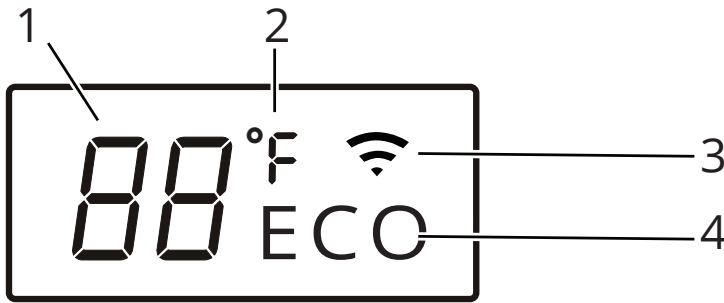

Fig. 1.2

Display (on front panel of indoor unit) see fig. 1.2

1. Digital Display:

Displays the Temperature Setting when the air conditioner is operational.
Displays the Room Temperature when in FAN mode.
Displays the self-diagnostic codes.
Displays **"ON"** for three seconds when the Timer is ON and/or Fresh, Swing, Turbo or Silence feature is activated.
Displays **"OF"** for three seconds when the Timer is switched OFF.
Displays **"OF"** for three seconds when the Fresh, Swing, Turbo or Silence feature is canceled.
Displays **"dF"** when Defrosting operation is active.
Displays **"cF"** when Anti-Cold Air feature is active in HEAT mode (when air temp is low).
Displays **"SC"** during Self Clean operation (if feature is available).
Displays **"FP"** when Freeze Protection is active, operating under 46.4 °F (8 °C) (if feature is available).

2. Units of Measurement:

Displays **"°C"** for Celsius or **"°F"** for Fahrenheit. Default units are **"°F"** (Fahrenheit) and can be switched by simultaneously pressing and holding both the up and down buttons on the remote control.

According to the operation mode (heat / cool, etc.), the Units of Measurement will display in different colors;

- Under Cool or Dry mode, it always displays as cool colors.
- Under Heat mode, it always displays as a warm color.









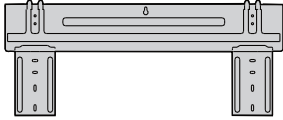

3. Wireless Mode:

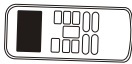
Displays when the wireless control feature is activated.

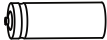
NOTE: A guide for using the infrared remote - "Remote Manual" - is included in this literature package.



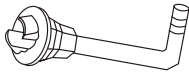

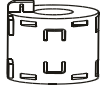
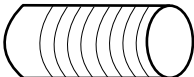



Overview - Accessories

The air conditioning system includes the following accessories. Use all of the installation parts and accessories to install the air conditioner. Improper installation may result in water leakage, electrical shock, fire, or equipment failure.

PART	LOOKS LIKE...	QUANTITY	
Mounting plate		1	
Anchor		5	
Mounting plate fixing screw		5	
Remote control		1	
Fixing screw for remote controller holder ST2.9 x 10		2	Optional Parts
Remote control holder		1	
Dry battery AAA.LR03		2	
Air freshening filter		1	
Seal		1	
Allen wrench		1	
Drain joint		1 (Only for use when elevated)	
Neoprene		1 (Sealant for Wall Sleeve)	
Line-Set Adapter Set (Included with 4-zone only)		1 liquid side adapter and 1 suction side adapter used for installing indoor units rated 24K BTU or greater.	
Magnetic Ring		1 (Attach to connective cable between indoor and outdoor unit to reduce static)	
Plastic Wall Sleeve		1	

Note: Illustrations are for explanatory purposes only - The actual shape may vary.

Overview - Accessories

PART	LOOKS LIKE...	QUANTITY
<p>Owner & Installation Manual</p>		<p>1</p>
<p>Remote Control Manual</p>		<p>1</p>
<p>Smart Controller Kit</p>		<p>1 (w/ Manual in Controller Box)</p>
<p>Sound deadening pads</p>		<p>2</p>
<p>Quick Connect® line set (refrigerant pipe)</p> <p>Line set sizes include: 16ft, 25ft</p>		<p>Depends on Purchase</p>
<p>Insulation material</p>		<p>2 (Apply to the quick connectors of the pipe)</p>
<p>Tape</p>		<p>4</p>
<p>Drain Pipe</p>		<p>16 ft (5m)</p>

	Cooling Operation	Heating Operation	Drying Operation
Room Temperature	63°F~90°F (17°C~32°C)	32°F~86°F (0°C~30°C)	50°F~90°F (10°C~32°C)
Outdoor Temperature	-13°F~122°F / -25°C~50°C	-13°F~86°F (-25°C~30°C)	32°F~122°F (0°C~50°C)

NOTE:

1. Optimum performance will be achieved within these operating temperatures. If the unit is used outside of the above conditions, certain safety protection features might come into operation and cause the unit to function abnormally.
2. If the air conditioner runs for a long time in cooling mode and the humidity is high (over 80%), condensed water may drip out of the unit. In this case, set the vertical air flow louver to its maximum angle (vertical toward the floor), and set it to **HIGH** fan mode.

Manual Operation

Units are equipped with a switch to run emergency operation mode. It can be accessed by opening the front panel. This switch is used for manual operation in case the remote fails to work or maintenance is necessary.

NOTE: The unit must be turned off before operating the manual control button. If the unit is operational, continue pressing the manual control button until the unit is off.

1. Open and lift the front panel up to an angle until it remains fixed with a clicking sound.
2. One press of the manual control switch will lead to the forced AUTO operation. If the switch is pressed twice within five seconds, the unit will operate under forced COOL operation.
3. Close the panel firmly to its original position.

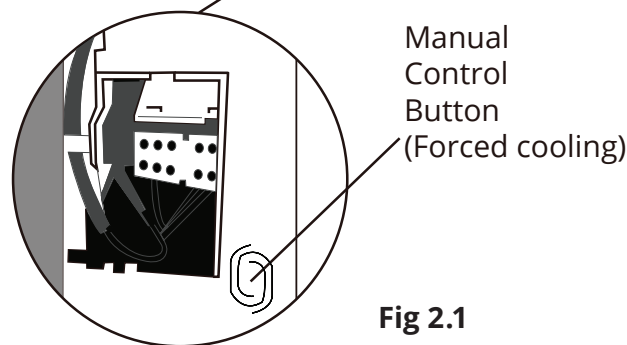
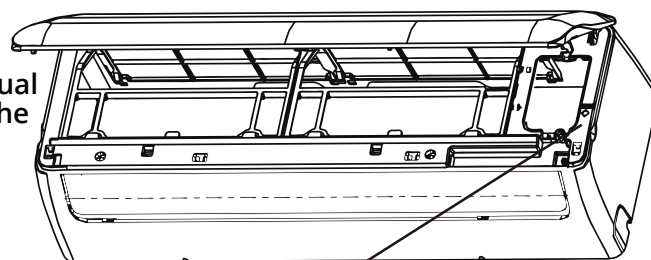

Fig 2.1

! CAUTION

- This switch is used for testing purposes only. Please do not use it unless necessary.
- To restore the remote control operation, use the remote control directly.

Operating Instructions

Airflow Directional Control

- Adjust the airflow direction properly. Otherwise, it may cause discomfort or uneven room temperatures.
- Adjust the vertical louver using the remote.
- Adjust the horizontal louver manually.

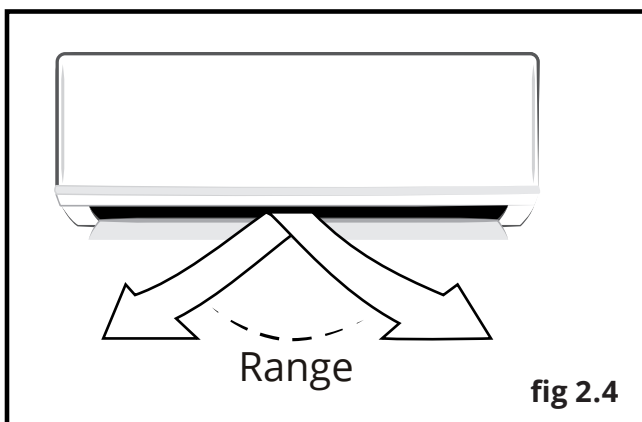
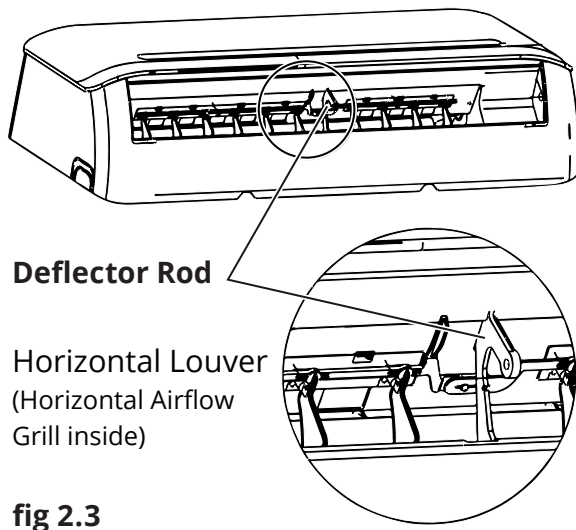
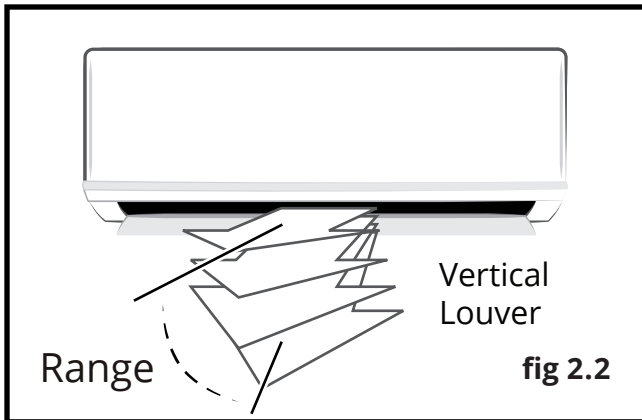

Adjust Vertical (Up / Down) Air Flow using Vertical Louver (fig 2.2):

Perform this function while the unit is in operation. Use the remote control to adjust the Vertical Louver / Vertical Air Flow direction. The vertical louver can move in small increments for each press, or continuously swing up and down automatically. Please refer to the “**REMOTE CONTROL USER MANUAL**” for details.

Adjust Horizontal (Left/ Right) Airflow using Horizontal Louver (fig 2.3, fig 2.4):

Move the Deflector Rod manually to adjust the air flow side to side (left / right) as desired.

! CAUTION

- ⚠ **DO NOT** put your fingers into the panel of the blower and suction side. The high speed fan inside may cause injury.
 - ⚠ **DO NOT** operate the unit for long periods of time with the airflow direction set downward in cooling or dehumidifying mode. Otherwise, condensation might occur on the surface of the vertical louver causing moisture to drop on to the floor or furnishings.
 - ⚠ **DO NOT** move the vertical louver manually. Otherwise, the vertical louver will be out of sync. If this happens, cease operation. Turn off the power to the unit, remove the wireless module from the front cover, turn off the power to the circuit (at the breaker), wait a few seconds, and turn the power back on at the breaker. Reinstall the wireless module and power the unit back on.
1. After a quick restart, the vertical louver may remain static for approximately 10 seconds.
 2. The open angle of the vertical louver should not be set too small, as it will restrict airflow and reduce **COOLING** and **HEATING** performance.

How the air conditioner works

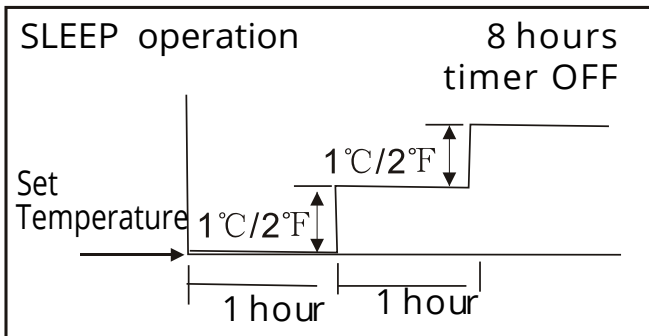

Cooling

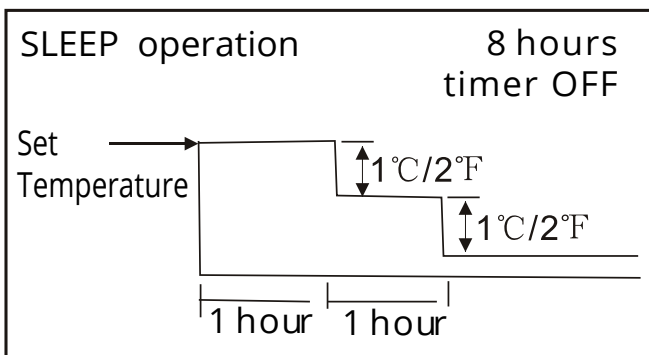

Heating

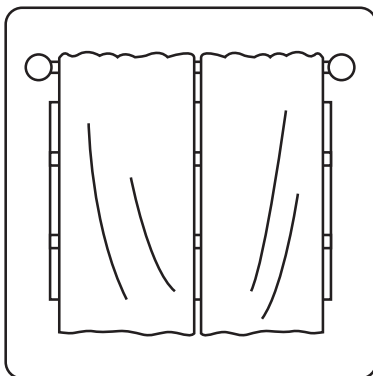

Closing the curtains while heating also helps keep the heat in

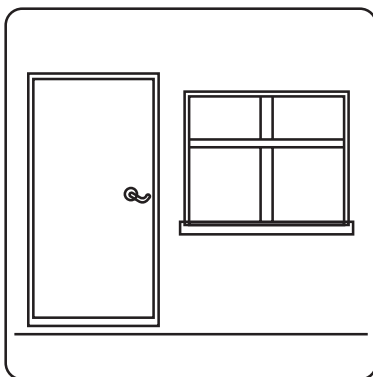

Doors and windows should be kept closed

Basic Operation Modes:

AUTO / COOL / DRY / HEAT (Model dependent).

Auto Operation:

When you set the air conditioner in **AUTO** mode, it will automatically select cooling, heating or fan-only operation depending on set temperature and room temperature.

The unit will control the room temperature automatically, according to the temperature point you set.

SLEEP Operation:

When selected, the temperature will increase while cooling or decrease while heating by 1°C / 2°F per hour for the first 2 hours. Thereafter it keeps this new temperature for 6 hours before **SLEEP** mode switches off.

DRYING Operation:

The temperature is regulated while dehumidifying by intermittently switching the cooling or fan-only operation on and off. The fan speed is set to **LOW**.

HEATING Operation:

This unit is a heat pump by design. By reversing the air conditioning process, it absorbs heat from outdoors and transfers it to the indoor unit. As a result, the operating performance and efficiency is reduced as the outdoor air temperature drops. If you feel that the heating performance is insufficient, it is recommended that you supplement heating with other appliances.

Optimal Operation:

To achieve optimal performance, please note the following:

- Adjust the airflow direction correctly, so that it is not towards people or at an extreme angle.
- Adjust the temperature to achieve moderate comfort levels. An excessively low or high temperature setting wastes energy.
- Keep windows and doors closed to improve performance.
- Limit energy usage (run time) by using the **TIMER** function.
- Do not put any objects near the air inlets / outlets. Doing so would impair performance and possibly shut down the unit.
- Inspect the air filters periodically and clean them as needed.

Operation Mode Selection

While two or more indoor units are simultaneously operating, make sure the modes do not conflict with each other. The heat mode claims precedence over all other modes. If the unit initially started to operate in **HEAT** mode, the other units can operate in **HEAT** mode only. For example: If the unit initially started operating under **COOL** (or **FAN**) mode, the other units can operate under any mode except **HEAT**. If one of the unit selects **HEAT** mode, the other operating units will stop operation and display "--" (for units with display window only) or the auto and operation indication light will flash rapidly, the defrost indication light will turn off, and the timer indication light will remain on (for units without a display window).

Special Functions

Refrigerant Leakage Detection (optional):

When refrigerant leakage is detected, the indoor unit will display "EC" or "ELOC" code or flash LEDs, depending on the model.

Louver Angle Memory Function (optional):

Within the scope of the safe operation angle, the horizontal louver angle is memorized and returns to the position last selected by the user. If it exceeds the safe operation angle, it will default within the safe operation range. However, it will not return to safe operation angle when Turbo mode is set or the unit is in manual control or after a power interruption. Subsequently, it is strongly recommended that the horizontal louver angle not be set too small, to avoid possible condensation leakage.

Anti-Mildew Function (optional):

When the unit is turned off, in **COOL**, **DRY**, **AUTO** (cool) modes, it will continue to run for about 10 minutes with a low fan airflow. This aids in drying up any condensation inside the unit to prevent mildew growth. Do not restart the air conditioner until the unit is completely off.

Optimal Operation:

In the event of a power interruption such as a blackout, the air conditioner will stop. It will then restart automatically and resume the previous operation when the power supply returns.

Wireless Smart Control Function:

Connect the wireless control module via the USB port in the back of the front cover of the indoor unit for the unit to be controlled by remote control and/or smartphone app.

Clean Air Filter Reminder (optional):

After 240 hours of operation, the indoor display window will display and flash "CL" as a reminder to **CLEAN** the air filter for more efficient operation. After 15 seconds, the system will revert back to the previous display again. When the "CL" indicator appears and flashes, please press the **LED** button on the remote control 4 times or press the manual control button 3 times to reset the hours. If you don't reset the reminder, the "CL" indicator will flash again when you restart the unit.

Replace Air Filter Reminder (optional):

After 2880 hours of operation, the indoor display window will display and flash "nF" as a reminder to **REPLACE** the air filter for more efficient operation. After 15 seconds, the system will revert back to the previous display again. When the "CL" indicator appears and flashes, please press the **LED** button on the remote control 4 times or press the manual control button 3 times to reset the hours. If you don't reset the reminder, the "nF" indicator will flash again when you restart the unit.

Mute Function (optional):

Press the **LED** button on the remote to turn off the **LED** display and silence the buzzer of the indoor unit to create a quiet and comfortable environment.

! CAUTION

Power supply must be disconnected before attempting to clean or service. Failure to do so can cause electrical shock.

- ⊘ **DO NOT** use benzene, thinner, polishing powder, or similar solvents for cleaning. These may cause the plastic to crack and/or deform.
- ⊘ **DO NOT** clean the unit with excessive amounts of water.
- ⊘ **DO NOT** touch the metal parts of the unit when removing the filter. Injuries can occur when handling the sharp metal edges.
- ⊘ **DO NOT** use water to clean inside the air conditioner. Exposure to water can destroy the insulation and possibly lead to electric shock.
- ⊘ **DO NOT** use a chemically treated cloth or duster to clean the unit.
- ⊘ **DO NOT** touch air freshening (Plasma) filter for at least 10 minutes after turning off the unit.
- ⊘ **DO NOT** clean the unit with combustible cleaning agents. These could cause fire or deformation.
- ⊘ **DO NOT** wash air filter with water hotter than 40°C / 104°F.
- ⊘ **DO NOT** expose the filter directly to the sun, it may shrink. Dry it in the shade.

Before performing maintenance, power off the unit. Then, disconnect the power circuit at the breaker.

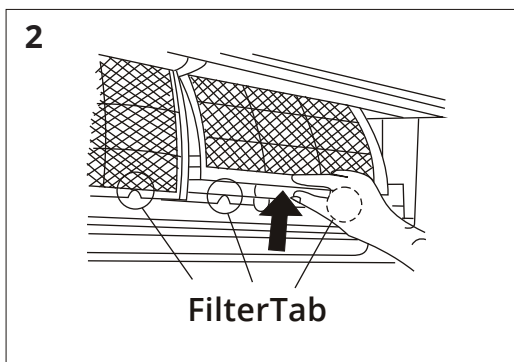
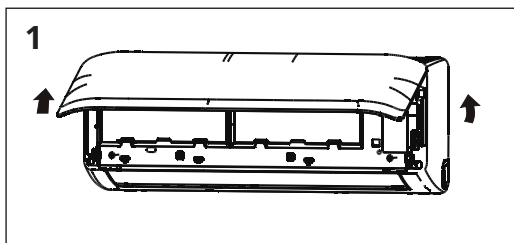

Cleaning the Unit:

Wipe the unit with a soft dry cloth. If the unit is very dirty, wipe it with a cloth soaked in warm water. **DO NOT** use bleach or abrasives.

Cleaning the Air Filter and Air Freshener:

A clogged air filter can greatly reduce the heating and cooling efficiency of this unit. It is recommended to clean the unit every 2 weeks. It is recommended to clean the filter every 30 days or bi-weekly if you have indoor pets.

1. Open the front panel by carefully lifting both ends at the same time. At a certain angle, there will be an audible click and the lid becomes self-supporting. For some models, suspension bars are provided and required to prop up the lid.
2. Use the filter tabs to lift the filter slightly upward and then toward you.

Care and Maintenance

3. Then, extract the filter by gently drawing it downward. Replace as necessary.
4. Unclip the small air freshening filter from the larger air filter. Replace as necessary. Otherwise, clean it with a vacuum and clip it back into place after cleaning the larger air filter as outlined in **Step 5**.
5. Clean the large air filter with warm, soapy water. Be sure to use a mild detergent. Rinse with fresh water. Shake off excess water and dry in a cool area.
6. Re-clip air freshening filter into large air filter.
7. Re-fit air filter back into the unit by reversing **Steps 2 and 3** - gently pushing the top up into the unit and then lowering the bottom into place.
8. Close the front panel. Make sure the buckles fully fit and the panel is completely closed.

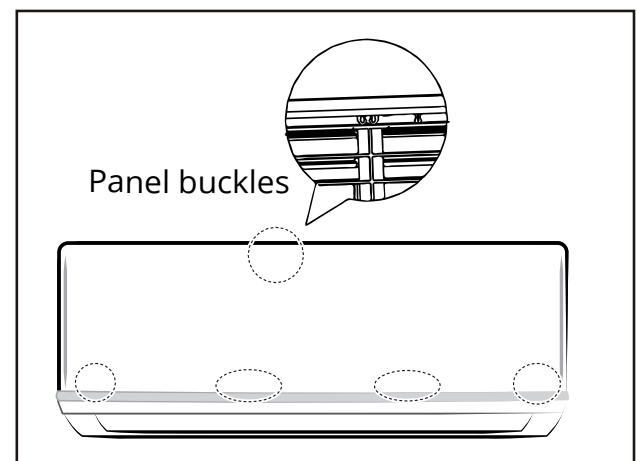
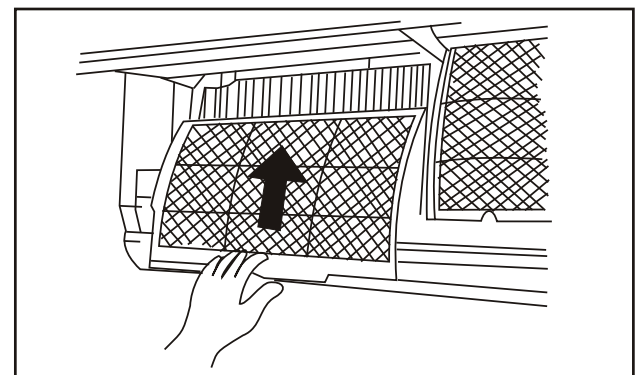
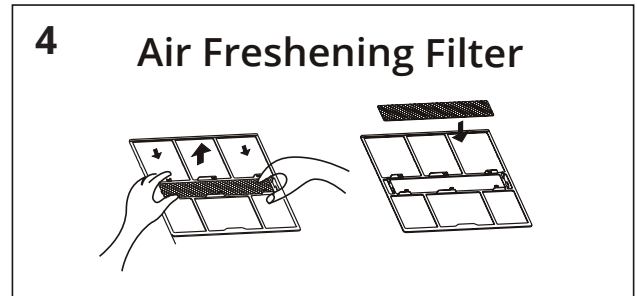
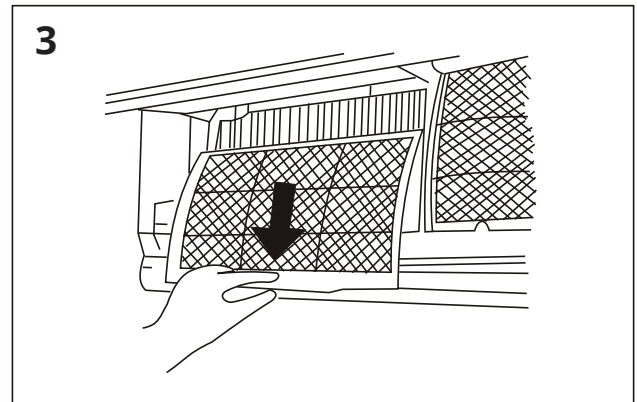

Preparation for Extended non-Operation:

If you plan not to run the unit for a long period of time (e.g. from the end of summer to the beginning of the following summer), perform the following:

1. Clean the indoor unit and filters as previously outlined.
2. Operate the unit in **FAN** only mode for at least 8 hours to dry out the inside of the unit.
3. Turn off the unit. Turn off the power circuit at the breaker. The unit should be the only appliance on the circuit.
4. Remove the batteries from the remote control.
5. The outdoor unit requires periodic maintenance as well. However, do not attempt this on your own. It is highly recommended that you contact a qualified service professional.

Pre-Season Inspection:

After prolonged non-operation, perform the following:

1. Check for Damaged or Disconnected Wires.
2. Clean the Indoor Unit and Filters
3. Check for Water and Oil Leaks
4. Check for Blockages in Airflow Inlet and Outlet
5. Replace Batteries

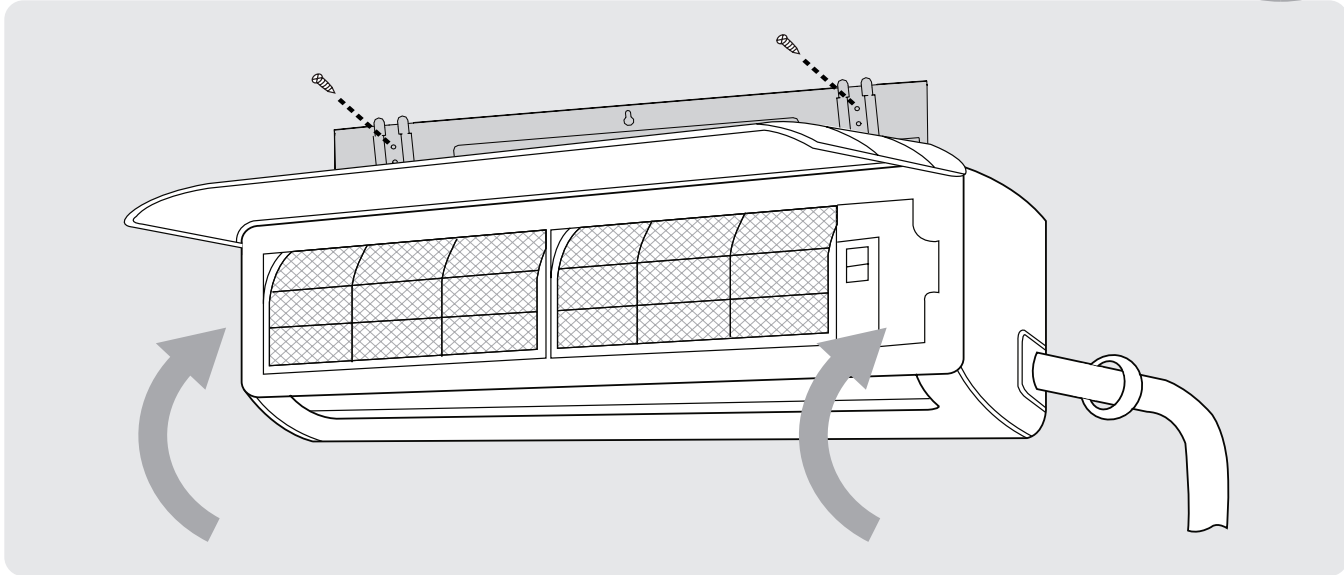

Installation Instructions – Indoor Unit

PRIOR TO INSTALLATION:

Before starting installation, verify the product series labels on the product boxes match the indoor unit and outdoor unit. All products must belong to the same series.

Step 1: Select installation location

Before installing the indoor unit, you must choose an appropriate location. The following standards will help you choose an appropriate location for the unit.

Proper installation locations meet the following standards:

- Good air circulation
- Convenient drainage
- Noise from the unit will not disturb other people
- Firm and solid—the location will not vibrate
- Strong enough to support the weight of the unit
- A location at least 3 ft (1m) from all other electrical devices (e.g., TV, radio, computer)

DO NOT install unit in the following locations:

- Near any source of heat, steam, or combustible gas
- Near flammable items such as curtains or clothing
- Near any obstacle that might block air circulation
- Near a doorway or where outside air may blow directly on indoor unit
- In a location subject to direct sunlight

NOTE ABOUT WALL HOLE:

If there is no fixed refrigerant piping: While choosing a location, be aware that you should leave ample room for a wall hole (see **Drill wall hole for connective piping** step) for the signal cable and refrigerant piping that connect the indoor and outdoor units. The recommended position for all piping is the right side of the indoor unit (while facing the unit). After piping and signal wiring are installed, use provided neoprene to pack the space making it airtight.

Refer to the following diagram to ensure proper distance from walls and ceiling:

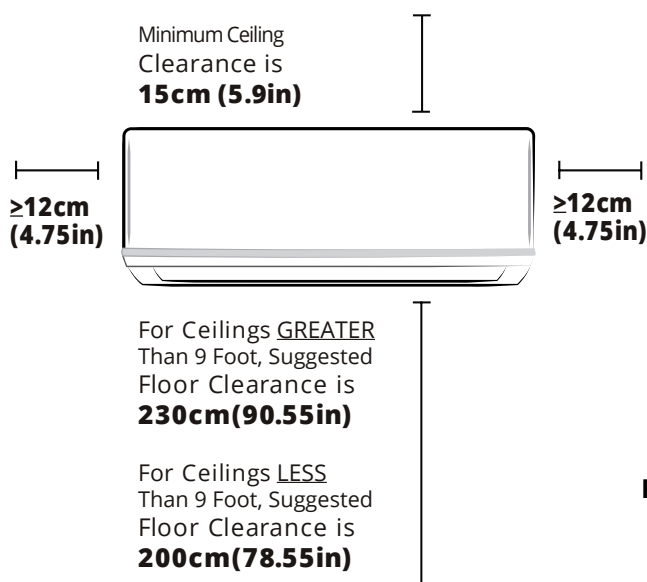

Fig. 5.1

Step 2: Attach mounting plate to wall

The mounting plate is the device on which you will mount the indoor unit.

1. Remove the screw that attaches the mounting plate to the back of the indoor unit.
2. Place the mounting plate against the wall in a location that meets the standards in the **Select Installation Location step**. See Mounting Plate Dimensions for detailed information on mounting plate sizes.
3. Drill holes for mounting screws in places that:
 - have studs and can support the weight of the unit
 - correspond to screw holes in the mounting plate
4. Secure the mounting plate to the wall with the screws provided.
5. Make sure that the mounting plate is flat against the wall.

NOTE FOR CONCRETE OR BRICK WALLS:

If the wall is made of brick, concrete, or similar material, drill 0.2in-diameter (5mm-diameter) holes in the wall and insert the sleeve anchors provided. Secure the mounting plate to the wall by tightening the screws directly into the clip anchors.

Step 3: Drill wall hole for connective piping

You must drill a hole in the wall for refrigerant piping, the drainage pipe, and the signal cable that will connect the indoor and outdoor units.

1. Determine the location of the wall hole based on the position of the mounting plate. Refer to Mounting Plate Dimensions on the next page to help you determine the optimal position. Refer to **Fig. 5.3** wall hole diameter and install at a slight angle to facilitate drainage.
2. Using a core drill [3.54in (76.2mm)], drill a hole in the wall. Make sure that the hole is drilled at a slight downward angle, so that the outdoor end of the hole is lower than the indoor end by about 0.2 to 0.275in (5mm-7mm). This will ensure proper water drainage. (See **Fig. 5.2**)
3. Place the protective wall cuff in the hole. This protects the edges of the hole and will help seal it when you finish the installation process.

! CAUTION

When drilling the wall hole, be sure to avoid wires, plumbing, nails, screws, and other sensitive components.

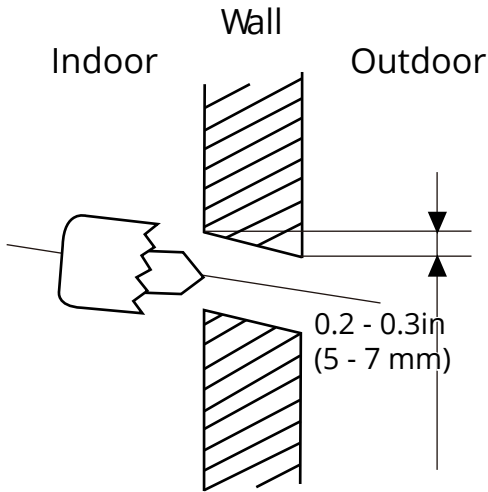

Fig.5.2

MOUNTING PLATE DIMENSIONS

Different models have different mounting plates. In order to ensure that you have ample room to mount the indoor unit, the diagrams to the right show different types of mounting plates along with the following dimensions:

- Width of mounting plate
- Height of mounting plate
- Width of indoor unit relative to plate
- Height of indoor unit relative to plate
- Recommended position of wall hole (both to the left and right of mounting plate)
- Relative distances between screw holes

Correct orientation of Mounting Plate

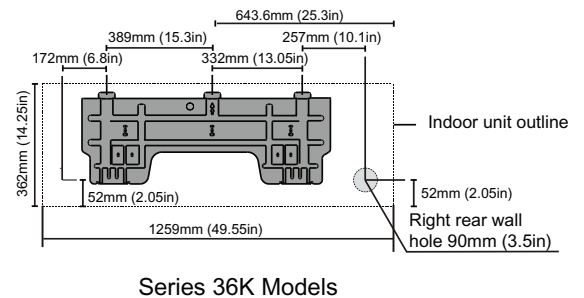
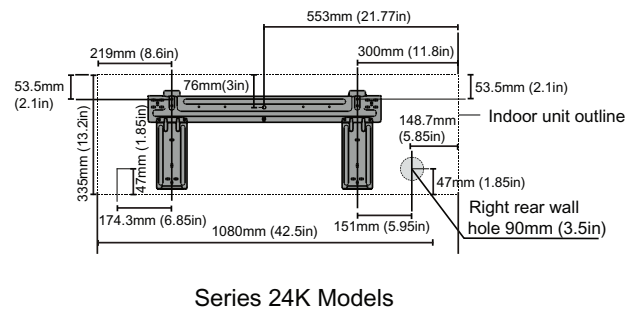
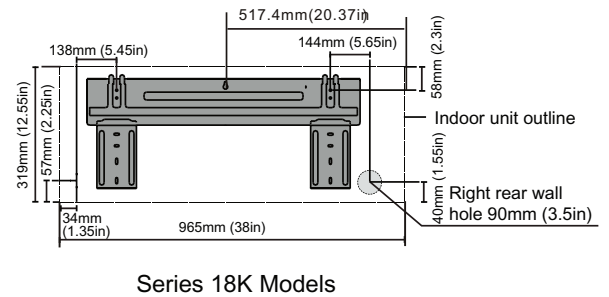
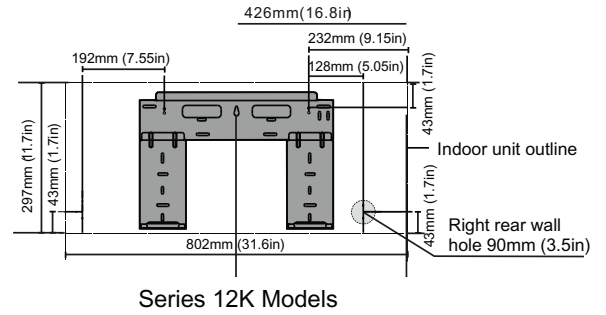
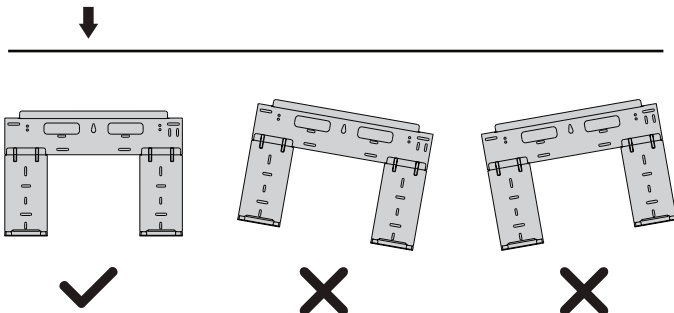

Fig. 5.3

Step 4: Prepare refrigerant piping

The refrigerant piping is inside an insulating sleeve attached to the back of the unit. You must prepare the piping before passing it through the hole in the wall. Refer to the Refrigerant Piping Connection section of this manual for detailed instructions on torque requirements, technique, etc.

1. The piping will exit the unit from the right side of the air handler.
2. Connect the indoor refrigerant piping to the connective piping that will join the indoor and outdoor units.
3. Based on the position of the wall hole relative to the mounting plate, determine the necessary angle of your piping.
4. Grip the refrigerant piping at the base of the bend.
5. Slowly, with even pressure, bend the piping towards the hole. **DO NOT** dent or damage the piping during the process.

NOTE ON PIPING ANGLE

Refrigerant piping should exit the indoor unit from the right-hand side:

Refer to Fig. 5.4 for details.

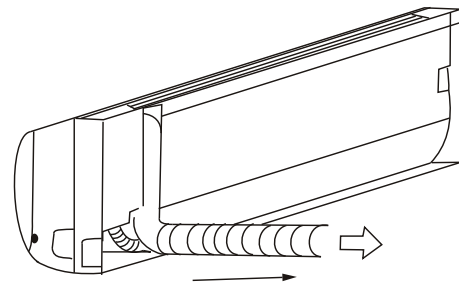
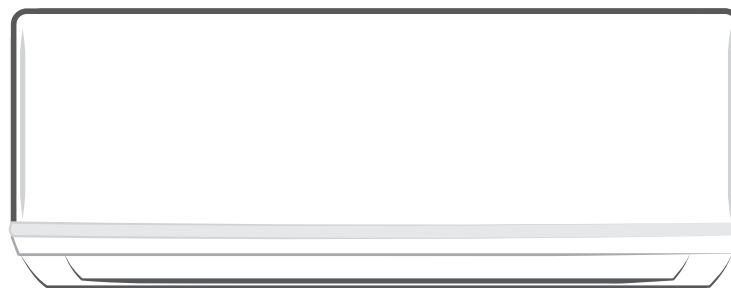



Fig. 5.4

UNIT IS ADJUSTABLE

Keep in mind that the hooks on the mounting plate are smaller than the holes on the back of the unit. If you find that you don't have ample room to connect embedded pipes to the indoor unit, the unit can be adjusted left or right by about 30-50mm (1.25-1.95in), depending on the model.

1.2-1.95in
(30-50mm)



1.2-1.95in
(30-50mm)



Fig. 5.10

Move to left or right

! CAUTION

Be extremely careful not to dent or damage the piping while bending them away from the unit. Dents in the piping will affect performance. If you dent or damage the piping, cease manipulation immediately and contact MRCOOL technical support at (270) 366-0457.

Step 5: Connect Refrigerant Piping to Indoor Unit

5.1 Tools Needed

You will require the following tools to carry out this installation work correctly:

- 1x crescent wrench, 19 mm
- 1x crescent wrench, 22 mm/24mm
- 1x crescent wrench, 24 mm/27mm
- 1x Allen key, 5 mm
- 1x Philips screwdriver
- 1x leak detection spray or alternatively soap suds (water/detergent mix)

5.2 Important Information

- Follow the detailed instructions for connecting the refrigerant pipes to the indoor unit and outdoor unit. **We can only provide a warranty if the lines are installed correctly as described in the instructions.**
- If you are using a 24K Air Handler with a 4-zone condenser, you will need to use the lineset adapter kit that is included with the 4-zone condenser for that lineset connection.

- Remove the plastic side panel to access the lineset connectors.
- Remove the connector at the bottom by unthreading by hand and then replace with the adapter. This will allow the fitting to work with the 24K air handler.



Line Set Adapter Kit

- **DO NOT** remove the sealing caps and stoppers until immediately before you install the lines.
- To prevent leaks, ensure that the quick-release screw connections are absolutely free of dirt. Moisture or foreign bodies will adversely affect the function of the quick-release connectors, leading to a risk of refrigerant loss (not covered by the warranty).
- Only install refrigerant lines outdoors in dry weather.
- The refrigerant lines must not be plastered over after installation.
- Please make sure that refrigerant is never allowed to enter the environment. Improper handling of refrigerant may be harmful to health. Always wear work gloves and goggles when handling refrigerant.
- Do not smoke during installation work. The equipment must never be operated without refrigerant lines connected; otherwise, the equipment will be damaged immediately.
- The screw connections may only be tightened using appropriate open ended (i.e. crescent or adjustable) wrenches.

Refrigerant Pipe Connectors (both ends):



If the screw connections are tightened with too little torque, they will leak. If they are tightened with too much torque, the screw connections may suffer damage. Please refer to the torque requirements section for more information. If you are not confident about connecting the refrigerant line connectors yourself, it is imperative that you contact the MRCOOL® customer service team or a professional for assistance.

IMPORTANT:

The EQ valves are only designed for one-time installation. Their seal can not be guaranteed if they are installed on more than one occasion. This will also void the warranty.

5.3 Connecting the refrigerant pipes to the indoor unit

1. Do not remove the plastic seals from the indoor equipment and the appropriate refrigerant pipe until immediately before you connect them.
2. Align the refrigerant pipes correctly, make sure the dimensions of the connecting refrigerant pipe are the same. Place the screw connector on the refrigerant pipes just on to the thread on the indoor equipment and tighten the first few threads by hand.

IMPORTANT:

Before you continue, it is essential that you read the following instructions carefully.



! TORQUE REQUIREMENTS

1. Excessive force can break the nut or damage the refrigerant piping. You must not exceed torque requirements shown in the table below.
2. You can find the Outer Pipe Diameter stamped (in inches) on the valve set of the condenser. Refer to this when finding and applying the torque values in the table below.
3. Note that there may be differences in Torque Wrenches (i.e. automotive torque wrench versus a HVAC torque wrench) and that a socket style wrench cannot be used here.

Stamp	Outer Diameter of Pipe (in/mm)	Tightening Torque (lb·ft / N·m)	Add. Tightening Torque (lb·ft / N·m)
1/4"	Ø0.25" (Ø 6.35mm)	11 lb·ft (14.91 N·m)	11.8lb·ft (16 N·m)
3/8"	Ø0.375" (Ø 9.52mm)	18.4 lb·ft (24.95 N·m)	19.18lb·ft (26 N·m)
1/2"	Ø0.5" (Ø12.7mm)	25.8 lb·ft (34.98 N·m)	26.55lb·ft (36 N·m)
5/8"	Ø0.63" (Ø16mm)	33.19 lb·ft (45 N·m)	34.67lb·ft (47.01N·m)

3. Using open ended wrenches (i.e. crescent or adjustable), hold the points marked "1" and turn the nuts only at the points marked "2" (select the appropriate wrench according to the dimensions of the connector).

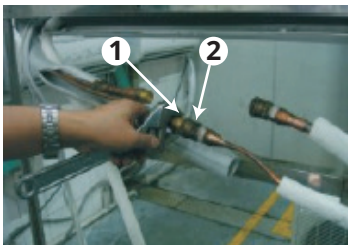

4. Ensure that the screw connectors do not skew as you tighten them and work quickly.

IMPORTANT: Before you continue, it is essential that you read the following instructions carefully.



5. After finishing the connection, use the tape to wrap the refrigerant pipe and connecting cable together.



6. After you finish connecting the quick connectors, pass the drain hose and refrigerant pipes through the wall hole as shown here.



NOTE:

The Quick Connect® must be placed outside of the room. Using the wall hole sleeve, cap and neoprene to seal the wall hole.

- 7 In order to prevent Quick Connect® parts from being exposed to air, sound deadening pads should be used during the installation.



8. Wrap the Quick Connect® with the sound deadening pads, pack down the pads tightly as shown here.



9. Wrap up the Quick Connect® with the black insulation material. For the top exposed part, use the white insulation material (supplied in Accessories box) to wrap completely as shown here.



10. Lastly, use tape to wrap the refrigerant pipe and connecting cable together.

Step 6: Connect drain hose

By default, the drain hose is attached to the left-hand side of unit (when you're facing the back of the unit). However, it can also be attached to the right-hand side.

1. To ensure proper drainage, the drain hose must exit the unit on the same side as the refrigerant piping.
2. Wrap the connection point firmly with included tape to ensure a good seal and to prevent leaks.
3. For the portion of the drain hose that will remain indoors, wrap it with included insulation material to prevent condensation.
4. Remove the air filter and pour a small amount of water into the drain pan to make sure that water flows from the unit smoothly.

NOTE ON DRAIN HOSE PLACEMENT

! CAUTION

Make sure to arrange the drain hose according to Fig. 5.5a.

- ⊘ DO NOT kink the drain hose.
- ⊘ DO NOT create a water trap.
- ⊘ DO NOT put the end of drain hose in water or a container that will collect water.

ENSURE UNUSED DRAIN HOLE IS PLUGGED

To prevent unwanted leaks, be sure that the factory installed rubber plug is in the unused drain hole.

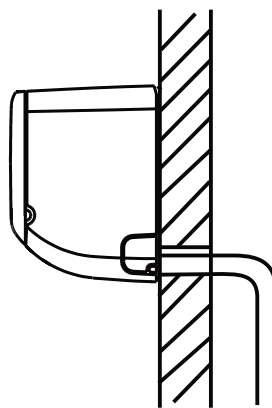

Fig. 5.5a

Make sure there are **NO** kinks or dents in the hose to ensure proper drainage.

NOT CORRECT
Kinks in the drain hose will create water traps.

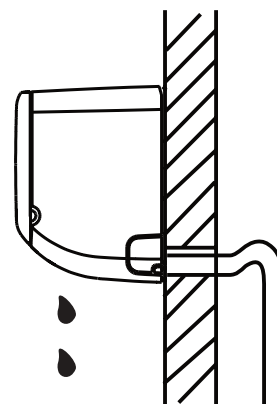

Fig. 5.5b

NOT CORRECT
Dents in the drain hose will create water traps.

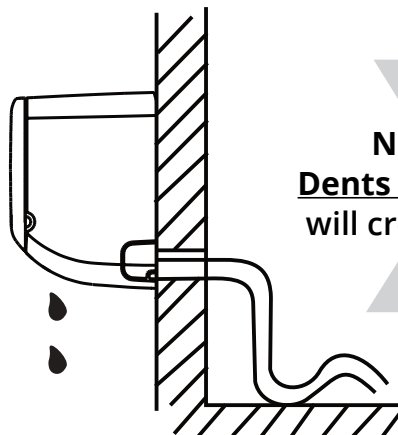

Fig. 5.5c

NOT CORRECT
DO NOT place the end of the drain hose in water or in containers that collect water. This will prevent proper drainage.

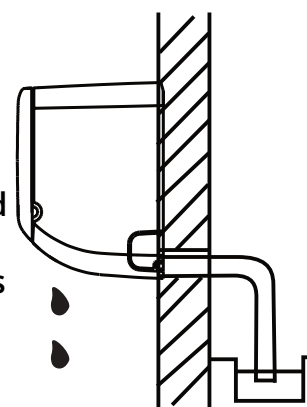
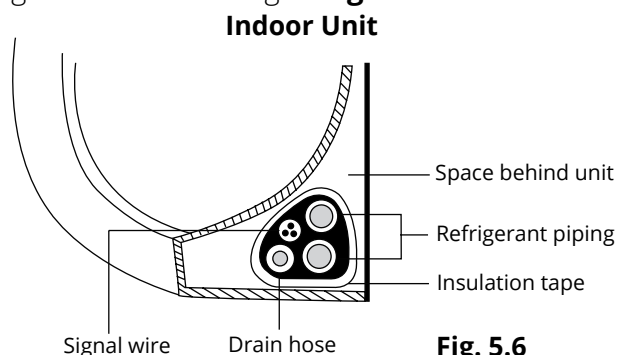

Fig. 5.5d

Step 7: Wrap piping and cables

Before passing the piping, drain hose, and signal cable through the wall hole, you must bundle them together to protect them, and tightly wrap them together with the provided tape.

1. Bundle the drain hose, refrigerant pipes, and signal cable according to **Fig. 5.6**.



DRAIN HOSE MUST BE ON BOTTOM

Make sure that the drain hose is at the bottom of the bundle. Putting the drain hose at the top of the bundle can cause the drain pan to overflow, which may lead to fire or water damage.

DO NOT INTERTWINE SIGNAL CABLE WITH OTHER WIRES

While bundling these items together, do not intertwine or cross the signal cable with any other wiring.

2. Using adhesive vinyl tape, attach the drain hose to the underside of the refrigerant pipes.
3. Using insulation tape, wrap the signal wire, refrigerant pipes, and drain hose tightly together. See **Fig. 5.7** for example. Double-check that all items are bundled in accordance with **Fig. 5.6**.

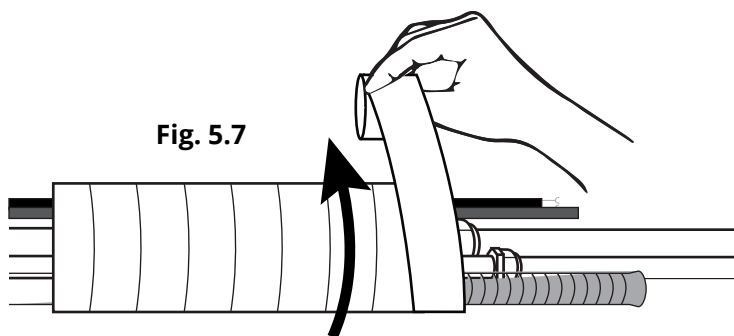

DO NOT WRAP ENDS OF PIPING

When wrapping the bundle, keep the ends of the piping unwrapped. You need to access them to test for leaks at the end of the installation process (refer to **Electrical Checks and Leak Checks** section of this manual).

Step 8: Mount indoor unit

If you installed new connective piping to the outdoor unit, do the following:

1. If you have already passed the refrigerant piping through the hole in the wall, proceed to **Step 4**.
2. Otherwise, double-check that the ends of the refrigerant pipes are sealed to prevent dirt or foreign material from entering the pipes.
3. Slowly pass the wrapped bundle of refrigerant pipes, drain hose, and signal wire through the hole in the wall.
4. Hook the top of the indoor unit on the upper hook of the mounting plate.
5. Check that unit is hooked firmly on mounting plate by applying slight pressure to the left and right-hand sides of the unit. The unit should not jiggle or shift.
6. Using even pressure, push down on the bottom half of the unit. Keep pushing down until the unit snaps onto the hooks along the bottom of the mounting plate.
7. Again, check that the unit is firmly mounted by applying slight pressure to the left and the right-hand sides of the unit.

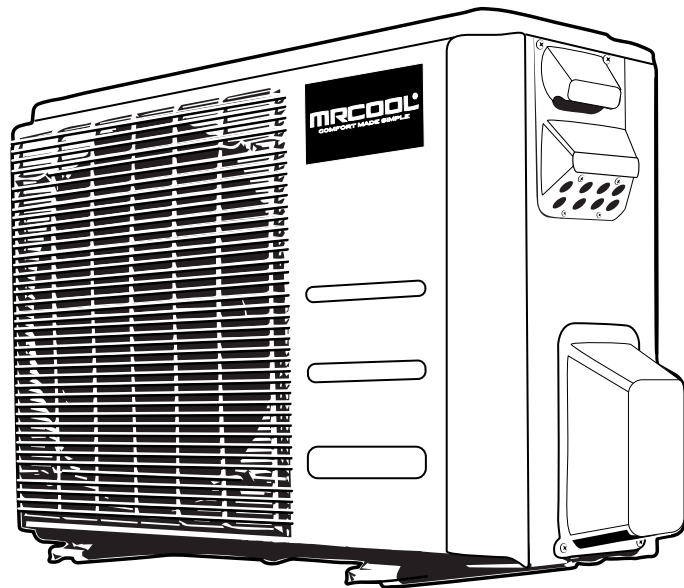

Installation Instructions - Outdoor Unit

Step 1: Select installation location

Before installing the outdoor unit, you must choose an appropriate location. The following standards will help you choose an appropriate location.

Proper installation locations meet the following standards:

- ☑ Meets all spatial requirements shown in Installation Space Requirements (Fig. 6.1)
- ☑ Good air circulation and ventilation
- ☑ Firm and solid location that can support the unit and will not cause vibration
- ☑ Noise from the unit will not disturb others
- ☑ Protected from prolonged periods of direct sunlight or rain

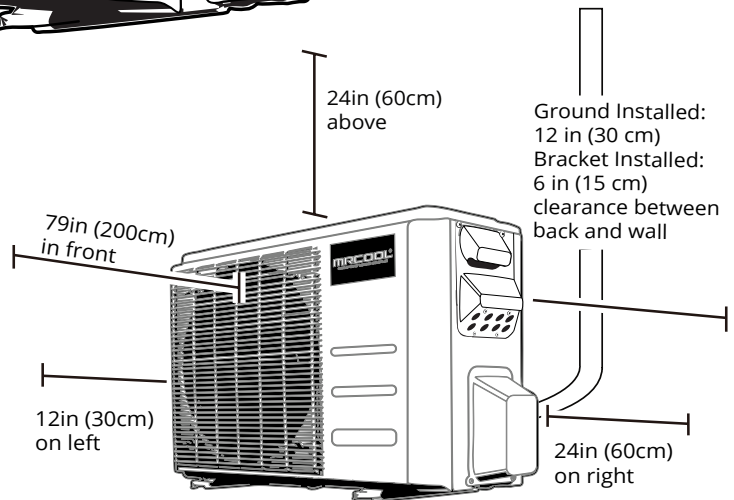

Fig. 6.1

DO NOT install unit in the following locations:

- ⊘ Near an obstacle that will block air inlets and outlets
- ⊘ Near a public street, crowded areas, or where noise from the unit will disturb others
- ⊘ Near animals or plants that will be harmed by hot air discharge
- ⊘ Near any source of combustible gas in a location that is exposed to large amounts of dust
- ⊘ In a location exposed to a excessive amounts of salty air
- ⊘ In a location that exposes the unit to large amounts of forced water

Outdoor Unit Installation

SPECIAL CONSIDERATIONS FOR EXTREME WEATHER

If the unit is exposed to heavy wind: Install unit so that air outlet fan is at a 90° angle to the direction of the wind. If needed, build a barrier in front of the unit to protect it from extremely heavy winds. Ensure the wind barrier does not block necessary air flow. See Fig. 6.2 and Fig. 6.3 below.

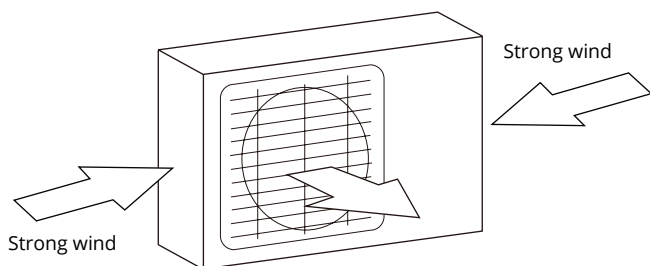

Fig. 6.2

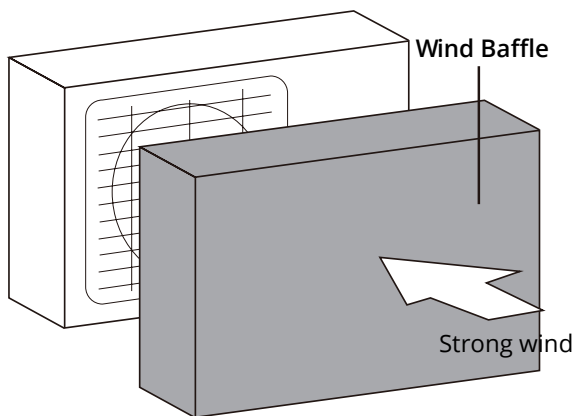

Fig. 6.3

If the unit is frequently exposed to heavy rain or snow:

Build a shelter above the unit to protect it from the rain or snow. Be careful not to obstruct air flow around the unit.

Step 2: Install drain joint

Heat pump units require a drain joint **ONLY** if the unit is elevated. **DO NOT** install if the unit is sitting on the ground or concrete pad.

Before bolting the outdoor unit in place, you must install the drain joint at the bottom of the unit. Note that there are two different types of drain joints depending on the type of outdoor unit.

If the drain joint comes with a rubber seal

(see Fig. 6.4 - A), do the following:

1. Fit the rubber seal on the end of the drain joint that will connect to the outdoor unit.
2. Insert the drain joint into the hole in the base pan of the unit.
3. Rotate the drain joint 90° until it clicks in place facing the front of the unit.
4. Connect a drain hose extension (not included) to the drain joint to redirect water from the unit during heating mode.

If the drain joint doesn't come with a rubber seal

(see Fig. 6.4 - B), do the following:

1. Insert the drain joint into the hole in the base pan of the unit. The drain joint will click in place.
2. Connect a drain hose extension (not included) to the drain joint to redirect water from the unit during heating mode.

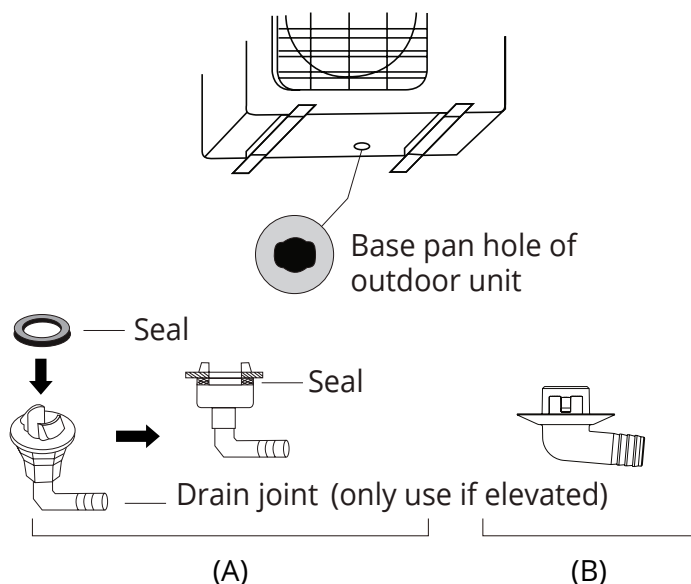

Fig. 6.4

! IN COLD CLIMATES

In cold climates, make sure that the drain hose is as vertical as possible to ensure swift water drainage. If water drains too slowly, it can freeze.

Outdoor Unit Installation

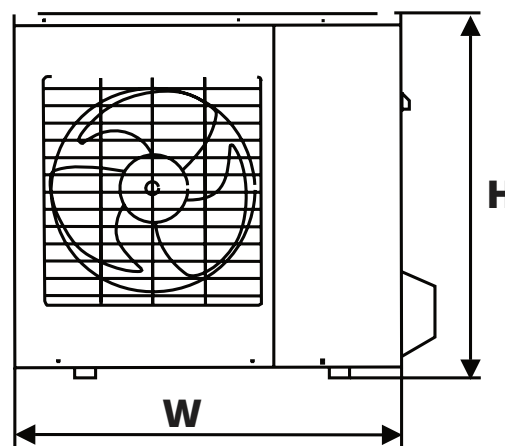
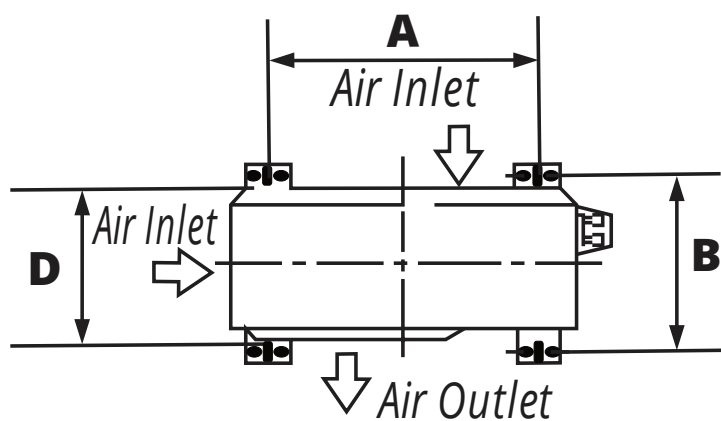

Fig. 6.5

Step 3: Anchor outdoor unit

The outdoor unit can be anchored to the ground or to a wall-mounted bracket.

UNIT MOUNTING DIMENSIONS

See below for the multi-zone condenser sizes and the distance between their mounting feet. Prepare the installation base of the unit according to the dimensions below.

	Outdoor Unit Dimensions (inches)		Mounting Dimensions (inches)	
	Width (W)	Height (H) x Depth (D)	Width (A)	Depth (B)
DIY-MULTI3-27HP230	37.24 x 31.89 x 16.54 (inches) 946 x 810 x 420 mm		26.5 in. 673 mm	15.87 in. 403 mm
DIY-MULTI4-36HP230	37.24 x 31.89 x 16.54 (inches) 946 x 810 x 420 mm		26.5 in. 673 mm	15.87 in. 403 mm

If you install the unit on the ground or on a concrete mounting platform, do the following:

1. Mark the positions for four expansion bolts based on dimensions in the Unit Mounting Dimensions chart.
2. Pre-drill holes for expansion bolts.
3. Clean concrete dust away from holes.
4. Place a nut on the end of each expansion bolt.
5. Hammer expansion bolts into the pre-drilled holes.
6. Remove the nuts from expansion bolts, and place outdoor unit on bolts.
7. Put washer on each expansion bolt, then replace the nuts.
8. Using a wrench, tighten each nut until snug.

WARNING

WHEN DRILLING INTO CONCRETE, EYE PROTECTION IS RECOMMENDED AT ALL TIMES.

Outdoor Unit Installation

If you install the unit on a wall-mounted bracket, do the following:

CAUTION

Before installing a wall-mounted unit, make sure that the wall is made of solid brick, concrete, or of similarly strong material. The wall must be able to support at least four times the weight of the unit.

1. Mark the position of bracket holes based on dimensions in the Unit Mounting Dimensions chart.
2. Pre-drill the holes for the expansion bolts.
3. Clean dust and debris away from holes.
4. Place a washer and nut on the end of each expansion bolt.
5. Thread expansion bolts through holes in mounting brackets, put mounting brackets in position, and hammer expansion bolts into the wall.
6. Check that the mounting brackets are level.
7. Carefully lift unit and place its mounting feet on brackets.
8. Bolt the unit firmly to the brackets.

TO REDUCE VIBRATION OF WALL-MOUNTED UNIT

If allowed, you can install the wall-mounted unit with rubber gaskets to reduce vibration and noise.

Indoor Air Handler Compatibility with Multi-Zone Condensers

OUTDOOR CONDENSER DIY-MULTI3-27HP230	
DIY-09-HP-WMAH-230B	DIY-18-HP-WMAH-230B
DIY-12-HP-WMAH-230B	DIY-24-HP-WMAH-230B Will only work for single zone application on this condenser

OUTDOOR CONDENSER DIY-MULTI4-36HP230	
DIY-09-HP-WMAH-230B	DIY-24-HP-WMAH-230B (Only 1 per Condenser)
DIY-12-HP-WMAH-230B	DIY-36-HP-WMAH-230B Will only work for single zone application on this condenser
DIY-18-HP-WMAH-230B	

Connective Pipe Size for Indoor Air Handlers

INDOOR UNIT CAPACITY (Btu/h)	LIQUID	GAS
9K/12K/18K	1/4	1/2
24K/36K	3/8	5/8

Connecting the refrigerant pipe to outdoor unit

! NOTE

To distinguish the connectors to be connected to the indoor unit and outdoor unit, the connectors of the refrigerant pipe have been labelled "A", "B", "C" and "D". Ensure the marks on the connector are the same to the indoor's and outdoor's respectively during connection.

! CAUTION

For your safety, always wear goggles and work gloves when connecting the pipes.

1. First remove the water tray on the outdoor unit as shown.

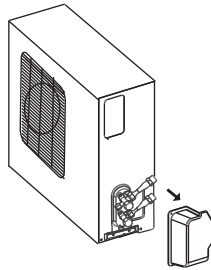

2. Do not remove the plastic seals from the outdoor unit and the appropriate refrigerant pipes until immediately before you connect them.

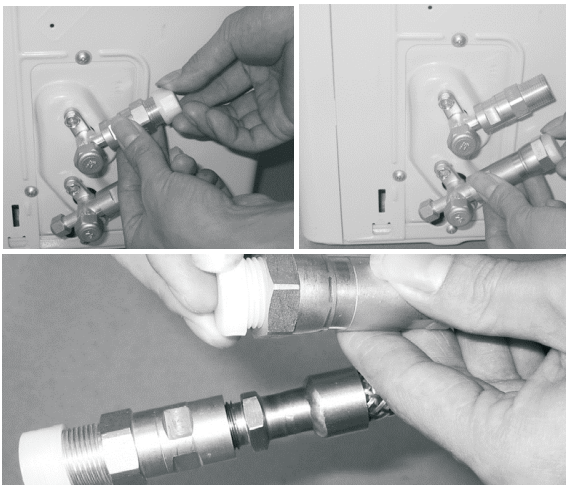

3. Align the refrigerant pipes correctly so that they line up with the valves and are not stressed. Place the screw connector on the refrigerant line just on to the thread on the outdoor unit and tighten the first few threads by hand.

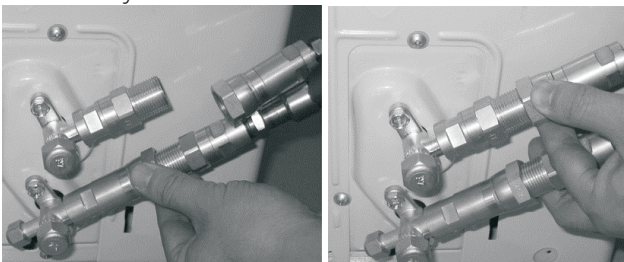

NOTE: The refrigerant pipes must be connected to the valves on the outdoor unit with as little stress as possible.

IMPORTANT: Before you continue, it is essential that you read the following instructions carefully.

4. Now tighten the bottom screw connector first and then the top screw connector using the open ended wrench (i.e. crescent or adjustable). Using the wrench, hold the points marked "1" and turn the nuts only at the points marked "2" (Select the appropriate wrench according to the dimensions of the connector).

Ensure that the screw connectors do not skew as you tighten them and work quickly. See below for the proper torque requirements.

! IMPORTANT

Since the coupling works with tapping rings, it may leak if you undo and reconnect the pipes. This will also void the warranty.

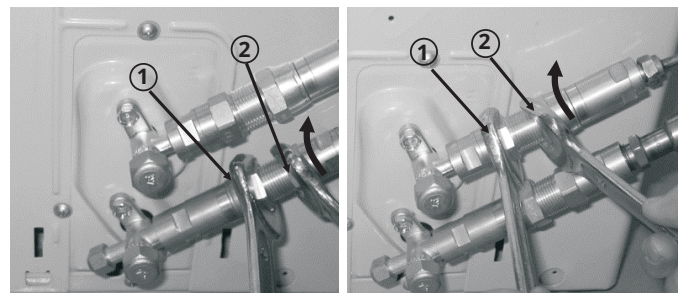

After completing steps 1- 4, check that all the connections are sealed correctly using leak detection spray or soap suds. If any bubbles form, the system has a leak and the screw connectors must be retightened using a crescent or adjustable wrench.

Refrigerant Piping Connection

Extend the pipe by unwinding it

1. Use your hands to slowly unwind the copper piping (Quick Connect® line set). Only unwind as much as necessary for use.
2. If the pipe is repeatedly bent or extended, it will become hard and difficult to manipulate. Avoid bending or extending the pipe for more than 3 times.
3. Do not bend the pipe excessively, otherwise it will break.

Refer to **Fig. 7.1**

MINIMUM BEND RADIUS

When bending connective refrigerant piping, the minimum bending radius is a 10cm. Refer to **Fig. 7.1**

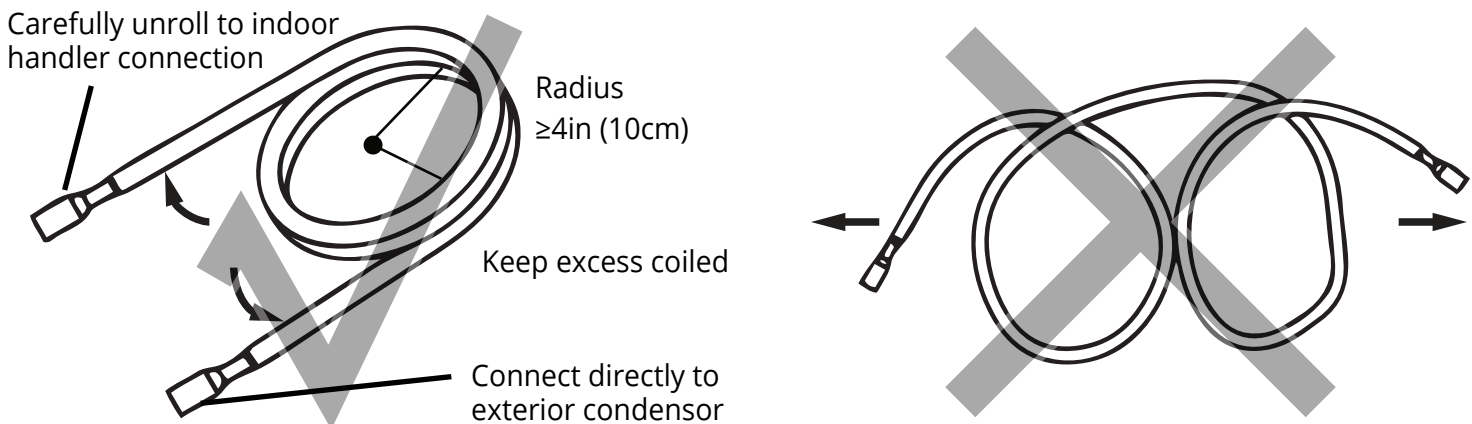

Fig. 7.1

! TORQUE REQUIREMENTS

1. Excessive force can break the nut or damage the refrigerant piping. You must not exceed torque requirements shown in the table below.
2. You can find the Outer Pipe Diameter stamped (in inches) on the valve set of the condenser. Refer to this when finding and applying the torque values in the table below.
3. Note that there may be differences in Torque Wrenches (i.e. automotive torque wrench versus a HVAC torque wrench) and that a socket style wrench cannot be used here.

Stamp	Outer Diameter of Pipe (in/mm)	Tightening Torque (lb·ft / N·m)	Add. Tightening Torque (lb·ft / N·m)
1/4"	Ø0.25" (Ø 6.35mm)	11 lb·ft (14.91 N·m)	11.8lb·ft (16 N·m)
3/8"	Ø0.375" (Ø 9.52mm)	18.4 lb·ft (24.95 N·m)	19.18lb·ft (26 N·m)
1/2"	Ø0.5" (Ø12.7mm)	25.8 lb·ft (34.98 N·m)	26.55lb·ft (36 N·m)
5/8"	Ø0.63" (Ø16mm)	33.19 lb·ft (45 N·m)	34.67lb·ft (47.01N·m)

Refrigerant Piping Connection

! CAUTION

All of these steps must be completed BEFORE powering on the unit. Failing to do so could damage the unit.

5. Now remove the cover on the top refrigerant connection valve using a 19 mm open ended wrench (i.e. crescent or adjustable). Open the valve by turning it counter-clockwise as far as it will go using a 5 mm Allen key. The valve is now open. If the valve is not opened fully, the system may malfunction and suffer damage. Screw the cover back on to the top valve and tighten it well to ensure that it is properly sealed.

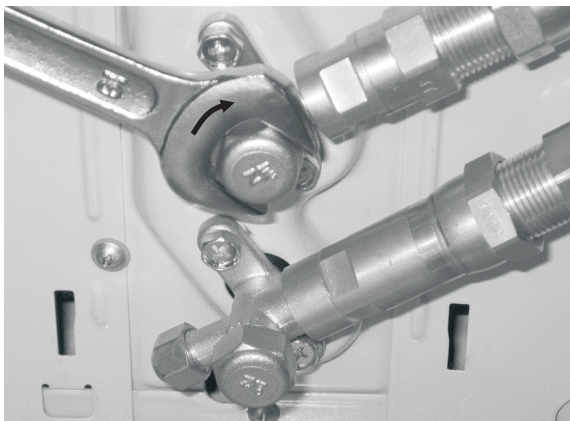
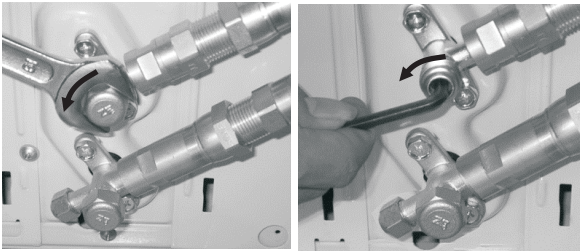

6. Now remove the cover on the bottom valve using a 19 mm crescent (or adjustable) wrench. Open the valve by turning it counter-clockwise as far as it will go using a 5 mm Allen key. The valve is now open. If the valve is not opened fully, the system may malfunction and suffer damage. Screw the cover back on to the bottom valve and tighten it well to ensure that it is properly sealed.

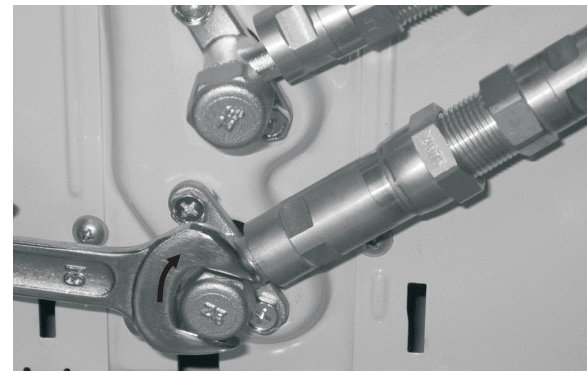
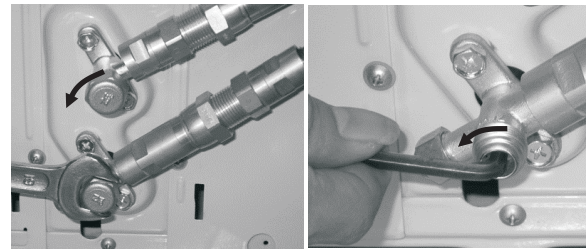

7. After completing steps 1- 6, repeat steps 2-6 for each lineset. Check that all of the connections are sealed correctly using leak detection spray or soap suds. If any bubbles form, the system has a leak and the screw connectors must be retightened using a crescent or adjustable wrench.

8. After opening all of the lineset connection valves, you must also open the two main valves (King Valve) as indicated after installation is complete. To do this, remove the plastic caps, and turn counter clockwise with a 5mm allen wrench.



9. Start the equipment so that the operating pressures build up inside the system. Check all the connectors again for signs of leaks

- a) during cooling mode
- b) in heating mode.

NOTE

If any bubbles form, the system has a leak and the screw connectors must be retightened.

Refrigerant Piping Connection

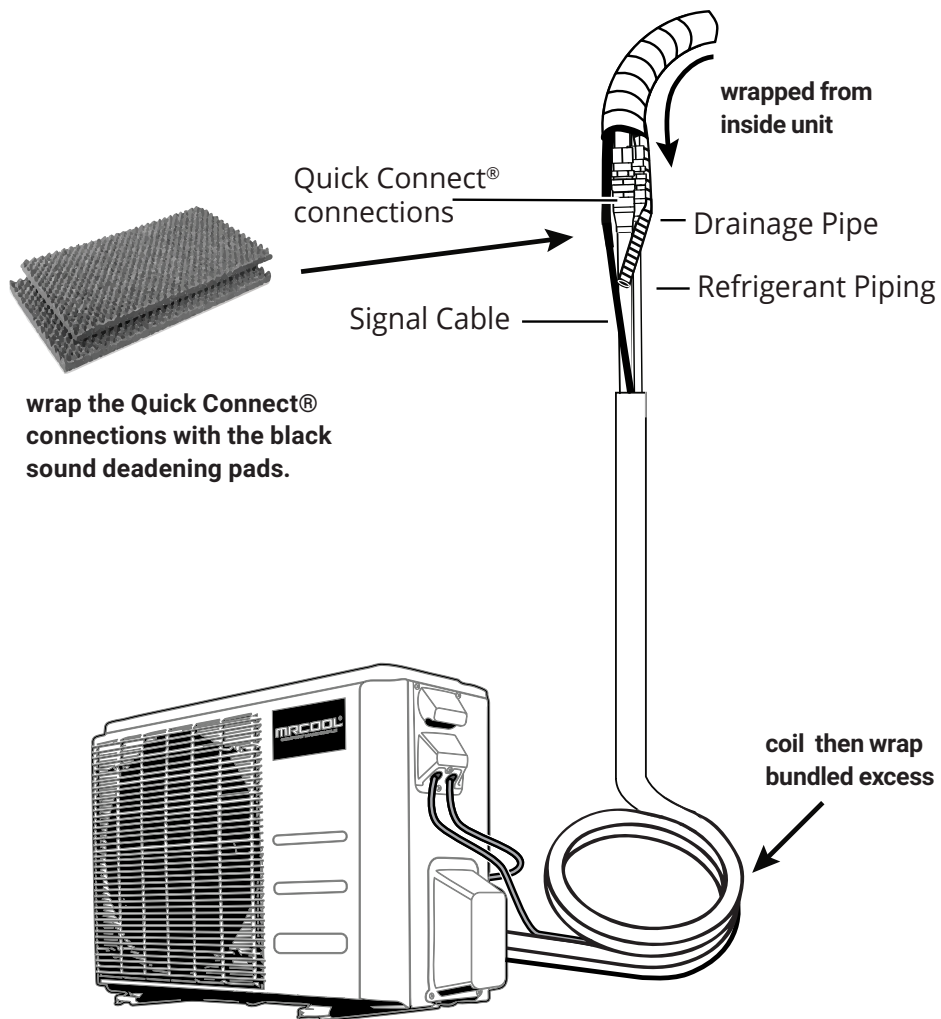

Outdoor Unit (Exterior / Condenser)



BEFORE PERFORMING ELECTRICAL WORK, READ THESE REGULATIONS

1. All wiring must comply with local and national electrical codes.
2. All electrical connections must be made according to the Electrical Connection Diagram located on the panels of the indoor and outdoor units.
3. If there is a serious safety issue with the power supply, stop work immediately. Explain your reasoning to the client, and refuse to install the unit until the safety issue is properly resolved.
4. Power voltage should be within 90-100% of rated voltage. Insufficient power supply can cause malfunction, electrical shock, or fire.
5. Circuit, including any switches, should have a capacity 1.5 times the maximum unit current (amps).
6. A qualified electrician must use an approved circuit breaker or switch that disconnects all poles and has a contact separation of at least 1/8in (3mm).
7. Do not connect another appliance to the same circuit.
8. Make sure to properly ground the air conditioner.
9. Every wire must be firmly connected. Loose wiring can cause the terminal to overheat, resulting in malfunction and possible fire. Double check that the screws are tightly fastened.
10. Do not let wires touch or rest against refrigerant tubing, the compressor, or any moving parts within the unit.
11. If the unit has an auxiliary electric heater, it must be installed at least 40in (1 meter) away from combustible materials.
12. To avoid getting an electric shock, never touch the electrical components soon after the power supply has been turned off. After turning off the power, always wait 10 minutes or more before you touch the electrical components.
13. Make sure that you do not cross your electrical wiring with your signal wiring. This may cause distortion and interference.
14. The unit must be connected to the main outlet. Normally, the power supply must have an impedance of 32 ohms.
15. Connect the outdoor wires before connecting the indoor wires.



WARNING

BEFORE PERFORMING ANY ELECTRICAL WORK, TURN OFF ALL POWER TO THE SYSTEM.

Note that wire colors of this series / model may differ from previous models, other series and general conventions. All wiring must be performed in accordance with the wiring diagrams shown in Fig. 7.1 and demonstrated in the images below.

DO NOT MIX UP LIVE AND NULL WIRES

This is dangerous and can cause the air conditioning unit to malfunction. Make sure you clearly distinguish the Live ("L") Wires from the other wires.

All wiring must be performed in accordance with the wiring diagrams shown in Fig. 7.1 and demonstrated in the images shown here.

Connect signal and power cables

The outside unit's terminal block is protected by an electrical wiring cover on the side of the unit. A comprehensive wiring diagram is printed on the inside of the wiring cover.

USE THE RIGHT CABLE

- Outdoor power cable: H07RN-F
- See table below for gauge requirements
- Indoor power / signal cable from outdoor unit is provided (see Indoor Unit Installation)

Minimum Wire Gauge for Power Cables North America

Model Series	Appliance Amps (A)	AWG
27K	35	8
36K	45	6

Other Regions

Rated Current of Appliance (A)	Nominal Cross-Sectional Area (mm ²)
> 3 and ≤ 6	0.75
> 6 and ≤ 10	1
> 10 and ≤ 16	1.5
> 16 and ≤ 25	2.5
> 25 and ≤ 32	4
> 32 and ≤ 40	6

1. Prepare the cable for connection:
 - a. Using wire strippers, strip the rubber jacket from both ends of cable to reveal about 1.57in (40mm) of the wires inside.
 - b. Strip the insulation from the ends of the wires.
 - c. Using a wire crimper, crimp u-lugs on the ends of the wires.



WARNING

ALL WIRING MUST BE PERFORMED STRICTLY IN ACCORDANCE WITH THE WIRING DIAGRAM LOCATED AS SHOWN IN FIG 8.2.

2. Unscrew the electrical wiring cover and remove it.
3. Unscrew the cable clamp below the terminal block and place it to the side.
4. Match the wire colors / labels with the labels on the terminal block, and firmly screw the u-lug of each wire to its corresponding terminal.
5. After checking to make sure every connection is secure, loop the wires around to prevent rain water from flowing into the terminal.
6. Using the cable clamp, fasten the cable to the unit. Screw the cable clamp down tightly.
7. Insulate unused wires with PVC electrical tape. Arrange them so that they do not touch any electrical or metal parts.
8. Replace the wire cover on the side of the unit, and screw it in place.

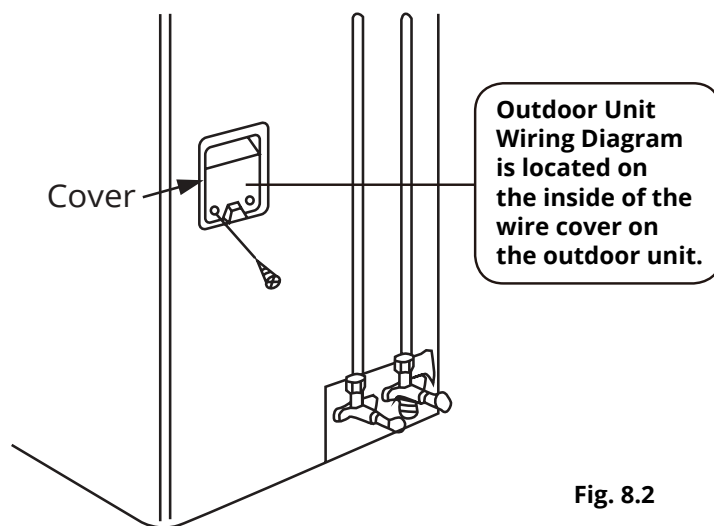

Fig. 8.2

NOTE ABOUT FUSE SPECIFICATIONS

The air conditioner's circuit board (PCB) is designed with a fuse to provide overcurrent protection. The specifications of the fuse are printed on the circuit board.

EXAMPLE Indoor unit: T3.15AL/250VAC, T5AL/250VAC, T3.15A/250VAC, T5A/250VAC, etc.

EXAMPLE Outdoor unit:
T20A/250VAC(≤18000Btu/h units),
T30A/250VAC(>18000Btu/h units), etc.

! CAUTION

Electrical work must be completed by a qualified electrical technician.

Connect the connective cables to the terminals, as identified below, with their matching numbers on the terminal block of the indoor and outdoor units. For example, in the US models shown in the following diagram, Terminal L1(A) of the outdoor unit must connect with terminal 1 on the indoor unit. Continue to match zone to zone for any additional connections.

See wiring diagram below and take note of the following precautions.

- Check the specifications for the power source before proceeding.
- Confirm that the electrical capacity is sufficient.
- Confirm that the cable thickness is as specified in the power source specifications.
- Always install an earth leakage circuit breaker in wet or moist areas.
- The following can be caused by a drop in voltage; vibration of a magnetic switch, damaging the contact point, broken fuses, and disturbance of normal functioning.
- Disconnection from a power supply must be incorporated into the fixed wiring. It must have an air gap contact separation of at least 3mm in each active (phase) conductors.
- Before accessing terminals, all supply circuits must be disconnected.
- If using magnetic rings (optional - not supplied), you must use the correct magnetic rings on your equipment to satisfy the EMC compulsory regulations required by the international standard CISPR 14-1:2005/A2:2011.

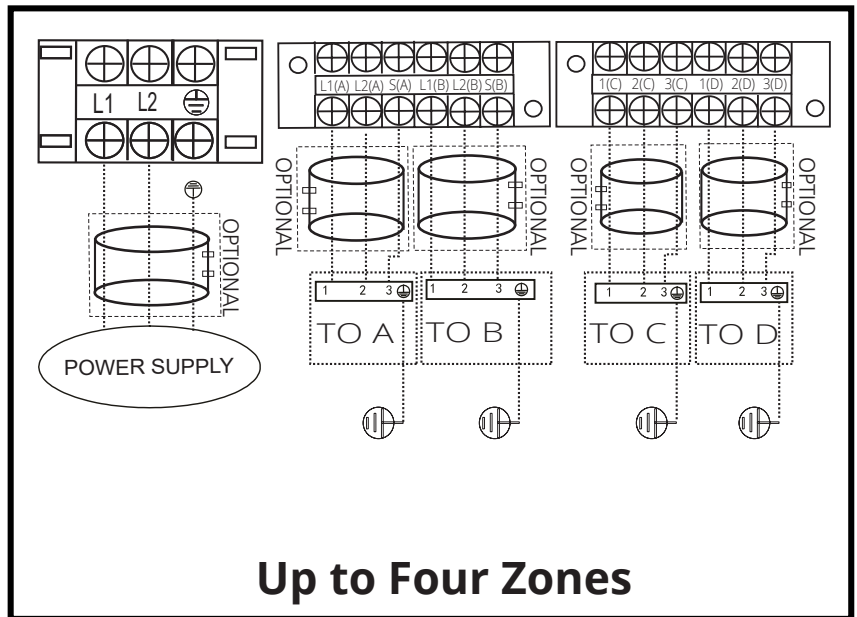
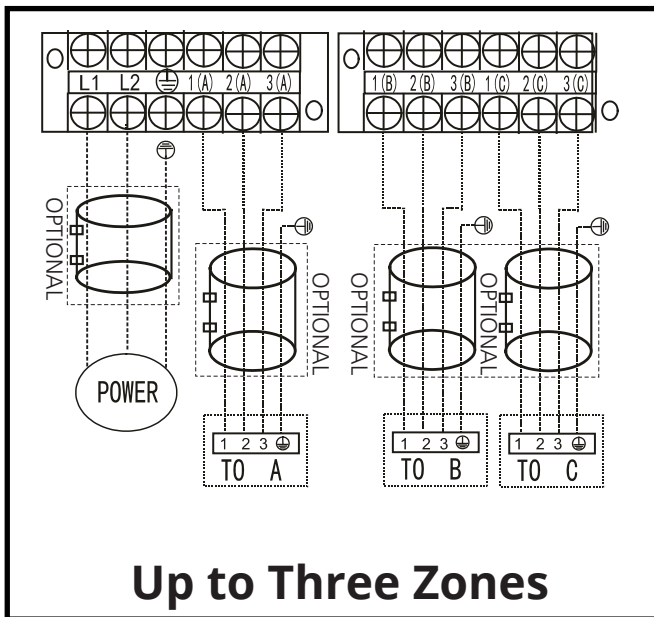

NOTE

This product is designed to run on 60Hz frequency which is the North American standard. Run the main power cord through the lower line-outlet of the cord clamp. Use a magnetic ring (not supplied, optional part) to hitch the connective cable of indoor and outdoor units after installation. One optional magnetic ring is used for one cable.

---- This symbol indicates field wiring.



This symbol indicates optional magnetic ring.

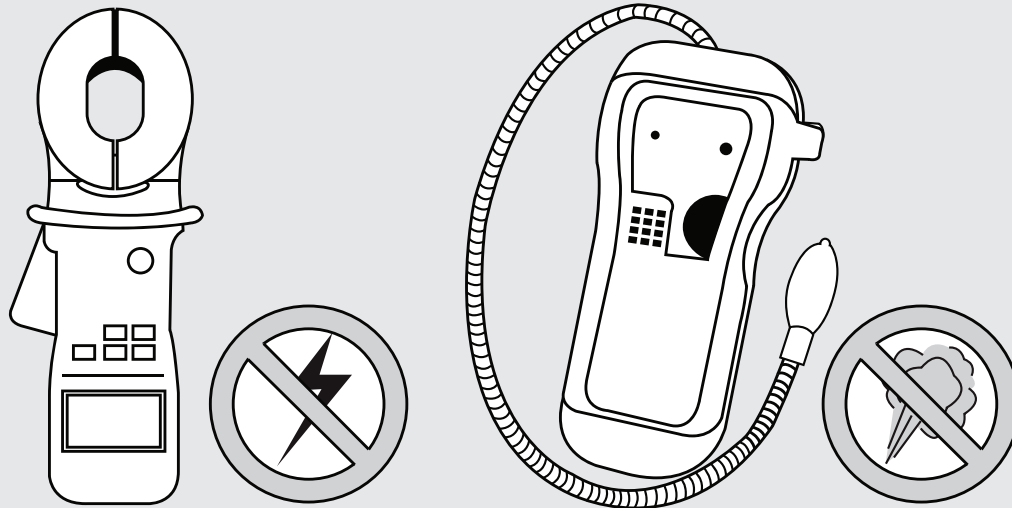

Electrical Safety Checks

After installation, confirm that all electrical wiring is installed in accordance with local and national regulations, and according to the Installation Manual.

BEFORE TEST RUN

Check Grounding Work

Measure grounding resistance by visual detection and with grounding resistance tester. Grounding resistance must be less than 4.

Note: This may not be required for some locations in the US.

DURING TEST RUN

Check for Electrical Leakage

During the Test Run, use an electroprobe and multimeter to perform a comprehensive electrical leakage test.

If electrical leakage is detected, turn off the unit immediately and allow an electrician to find and resolve the cause of the leakage.

Note: This may not be required for some locations in the US.



WARNING – RISK OF ELECTRIC SHOCK

ALL WIRING MUST COMPLY WITH LOCAL, STATE, AND NATIONAL ELECTRICAL CODES, AND MUST BE INSTALLED BY A LICENSED ELECTRICIAN.

Gas Leak Checks

There are two different methods to check for gaseous leaks.

Soap and Water Method

Using a soft brush, apply soapy water or liquid detergent to all pipe connection points on the indoor unit and outdoor unit. The presence of bubbles indicates a leak.

Leak Detector Method

If using leak detector, refer to the device's operation manual for proper usage instructions.

AFTER PERFORMING GAS LEAK CHECKS

After confirming that all the pipe connection points DO NOT leak, replace the valve cover on the outside unit.

Before Test Run

Only perform test run after you have completed the following steps:

- **Electrical Safety Checks** – Confirm that the electrical system is safe and operating properly
- **Gas Leak Checks** – Check all flare nut connections and confirm that the system is not leaking
- Confirm that gas and liquid (high and low pressure) valves are fully open

Test Run Instructions

You should perform the Test Run for at least 30 minutes.

1. Connect power to the unit.
2. Press the ON/OFF button on the remote controller to turn it on.
3. Press the MODE button to scroll through the following functions, one at a time:
 - **COOL** – Select lowest possible temperature
 - **HEAT** – Select highest possible temperature
4. Let each function run for 5 minutes, and perform the following checks:

List of Checks to Perform	PASS/FAIL	
No electrical leakage		
Unit is properly grounded		
All electrical terminals properly covered		
Indoor and outdoor units are solidly installed		
Wall Penetration Sleeve is packed airtight		
All pipe connection points do not leak	Outdoor (2):	Indoor (2):
Water drains properly from drain hose		
All piping is properly insulated		
Unit performs COOL function properly		
Unit performs HEAT function properly		
Indoor unit louvers rotate properly		
Indoor unit responds to remote control		

DOUBLE-CHECK PIPE CONNECTIONS

During operation, the pressure of the refrigerant circuit will increase. This may reveal leaks that were not present during your initial leak check. Take time during the Test Run to double-check that all refrigerant pipe connection points do not have leaks. Refer to **Gas Leak Check** section for instructions.

5. After the Test Run is successfully complete, and you confirm all check points in List of Checks to Perform have PASSED, do the following:
 - a. Using remote control, return unit to normal operating temperature.
 - b. Using insulation tape, wrap the indoor refrigerant pipe connections that you left uncovered during the indoor unit installation process.

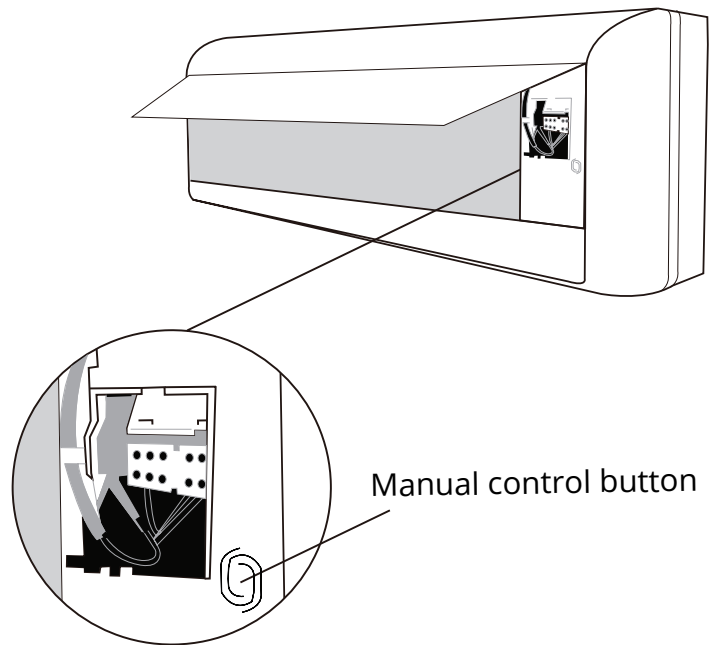

Fig. 10.1

IF AMBIENT TEMPERATURE IS BELOW 63°F (17°C)

You can't use the remote controller to turn on the COOL function when the ambient temperature is below 63°F. In this instance, you can use the MANUAL CONTROL button to test the COOL function.

1. Lift the front panel of the indoor unit, and raise it until it clicks in place.
2. The MANUAL CONTROL button is located on the right-hand side of the unit. Press it 2 times to select the COOL function. See Fig.10.1
3. Perform Test Run as normal.

! THANK YOU

Thank you for purchasing a MRCOOL ductless mini-split heating and air conditioning product.

MRCOOL is a young, family-owned company, so we are truly thankful you trusted us with your business. Should you need any technical support or just have questions about your MRCOOL product, please don't hesitate to call us at 270-366-0457.

And if you can spare a few minutes today, a review of your new MRCOOL® product on the partner site where you purchased it would really help us out. Real reviews from actual customers like you are invaluable to a growing company like ours.

Again, thanks for being a valued customer!

The following events may occur during normal operation, and may not indicate malfunction.

Symptom	Cause
Operation is delayed after restart	To prevent blowout of the fuse, the compressor will not operate while the protection circuit is working for about 3 minutes after sudden OFF--ON operation of the power supply.
Fan speed changes - off, very slow and then normal	Automatically happens in heating mode : --prevents cold air blowing onto occupants when heating operation starts --perform automatic defrosting operation --perform low temperature heating operation
Heating operation stops suddenly and defrost-light blinks	In HEAT mode, the indoor unit temporarily stops for maximum of 10 minutes to perform the automatic defrosting operation.
Mist coming out of the indoor unit	In COOL mode, a mist generated by condensation formed with sudden cooling process may be emitted.
	Mist may generate due to moisture from defrosting process when the air conditioner restarts in HEAT mode operation after defrosting.
Low volume sounds are emitted by the air conditioner	Hissing sound -- during operation or immediately after stopping the air conditioner, refrigerant flowing sound may be heard.
	Squeaking sound -- normal expansion and contraction of plastic and metal parts caused by temperature change during the operation.
	Rushing air -- when louver resets its position.
Dust discharges from the unit	May occur when air conditioner is used for the first time or has not been used for a long time.
Emits a peculiar odor	Various smells generated from interior textile, furniture, or cigarette smoke absorbed into the air conditioner may be emitted. If not the case, contact a local dealer or your installation contractor.
Changes to fan only while cooling or heating mode	Room temperature reaches the temperature setting of the remote control. If not the case, contact a local dealer or your installation contractor.
Voltage Fluctuations	The voltage can fluctuate within 10% above or below rated voltage. During start up, the voltage can drop within 15% of rated voltage. The voltage can be interval unbalanced within 3% above or below rated voltage.
Operation is erratic, unpredictable or unresponsive	Interference from cell phone towers and remote boosters may cause the unit to malfunction.
	Turn power off on unit and circuit at breaker, wait 10 seconds and power on.
	Press the ON/OFF button on the remote controller to restart operation.

NOTE: If the problem is not resolved, please contact a qualified service professional. Be sure to inform them of the detailed malfunctions and unit model number.

Troubleshooting

Before you call to request service assistance, troubleshoot a problem by performing the following checks:

Symptom	Diagnostic
Unit will not operate	-- Is there a power failure?
	-- Has a switch been turned off, a circuit breaker tripped or a fuse blown?
	-- Is the timer operating?
	-- Are the batteries used in the remote controller exhausted?
	-- Are the batteries used in the remote controller loaded properly?
Poor cooling or heating performance	-- Are the air filters dirty?
	-- Is air flow unrestricted in & out of indoor & outdoor units?
	-- Are the temperature and mode settings correct?
	-- Are the windows or doors left opened?
	-- Is fan speed on high and louvers allowing maximum flow?
	-- Is direct or strong sunlight shining into the room in cooling operation?
	-- Are there other heating apparatus or computers operating, or too many people in the room in cooling operation?
-- Is the SILENCE function activated? Under SILENCE operation, noise reduction is prioritized and the air-conditioning performance may become lower.	
Indicator lamps continue flashing	<p>-- The unit may stop operation or continue to run in a safety condition (depending on models). Waiting for about 10 minutes, the fault may be recovered automatically, if not, disconnect the power and then connect it again. If the problem still exists, disconnect the power and contact the nearest customer service center.</p> <p>Note that the wire colors of this series / model may differ from previous models, other series and general conventions. All wiring must be performed in accordance with the wiring diagrams shown in Section 8 and associated images. Wires and terminals are numbered to match accordingly.</p>
Error code appears in the indoor unit, such as: E0,E1,E2.... P1,P2,P3..... or F1, F2,F3.....	

NOTE: If the problem is not resolved, please contact a qualified service professional. Be sure to inform them of the detailed malfunctions and unit model number.



WARNING

In the case of ANY of the following, turn off the unit immediately!

- Signal / power cable is damaged or abnormally warm
- Burning odor
- Loud or abnormal sounds
- A power fuse or circuit breaker trips frequently
- Water or other objects fall into or out of the unit

DO NOT ATTEMPT TO CORRECT THESE ITEMS YOURSELF!

CONTACT A SERVICE PROFESSIONAL IMMEDIATELY

Indoor Unit Error Display

Operation LED	Timer LED	Display	LED STATUS
☒ 1 time	X	E0	Indoor unit EEPROM parameter error
☒ 2 times	X	E1	Indoor / outdoor units communication error **
☒ 3 times	X	E2	Zero-crossing signal detection error
☒ 4 times	X	E3/E88	Indoor fan speed has been out of control
☒ 5 times	X	E4	Indoor room temperature sensor T1 open circuit or short circuit
☒ 6 times	X	E5	Evaporator coil temperature sensor T2 open circuit or short circuit
☒ 7 times	X	EC	Refrigerant leakage detection
☒ 2 times	O	F1	Outdoor ambient temperature sensor T4 open circuit or short circuit
☒ 3 times	O	F2	Condenser coil temperature sensor T3 open circuit or short circuit
☒ 4 times	O	F3	Compressor discharge temperature sensor T5 open circuit or short circuit
☒ 5 times	O	F4	Outdoor unit EEPROM parameter error
☒ 6 times	O	F5	Outdoor fan speed has been out of control
☒ 1 time	☒	P0	IPM malfunction or IGBT over-strong current protection
☒ 2 times	☒	P1	Over voltage or over low voltage protection
☒ 3 times	☒	P2	High temperature protection of compressor top diagnosis and solution (only for 9k,12k models)
☒ 5 times	☒	P4	Inverter compressor drive error
X	X	P6	Discharge temp sensor
X	X	P7	USB Smart Controller module not installed

** Note that the wire colors of this series / model may differ from previous models, other series and general conventions. All wiring must be performed in accordance with the wiring diagrams shown in Section 8 and associated images. Wires and terminals are numbered to match accordingly.

O (light)

X (off)

☒ (flash)

Automatic Wiring/Piping Correction Function

NOTE

The function for the automatic wiring/piping correction illustrated below is intended for use by a licensed electrical technician only.

More recent models now feature automatic correction of wiring/piping errors. Press the "check switch" on the outdoor unit PCB board for 5 seconds until the LED displays "CE", indicating that this function is working. Approximately 5-10 minutes after the switch is pressed, the "CE" disappears, meaning that the wiring/piping error is corrected and all wiring/piping is properly connected.

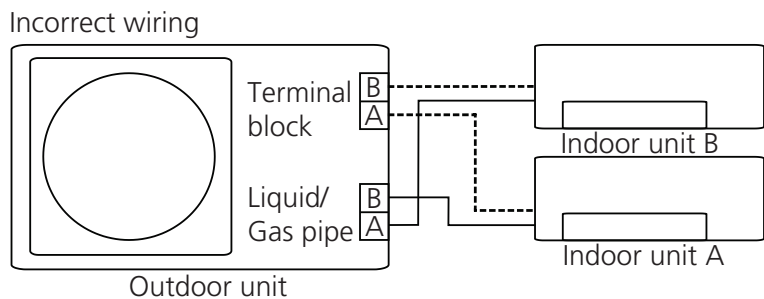
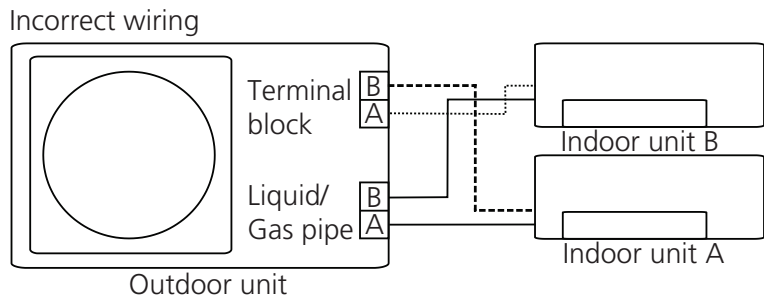
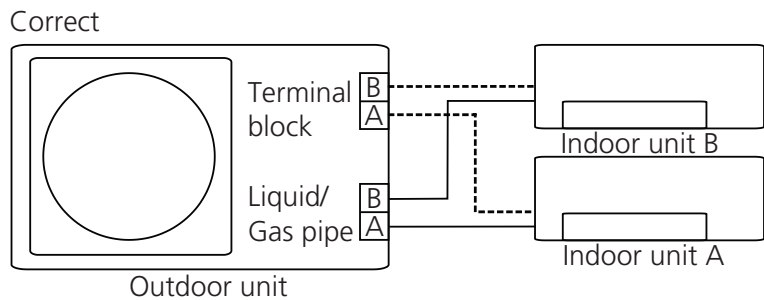
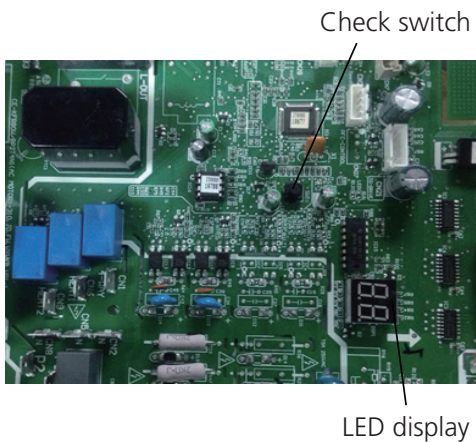

How To Activate This Function

1. Check that outside temperature is above 5 °C. (This function does not work when outside temperature is not above 5 °C)
2. Check that the stop valves of the liquid pipe and gas pipe are open.
3. Turn on the breaker and wait at least 2 minutes.
4. Press the check switch on the outdoor PCB board unit LED display "C E".

This appliance contains refrigerant and other potentially hazardous materials. When disposing of this appliance, the law requires special collection and treatment. DO NOT dispose of this product as household waste or unsorted municipal waste.

When disposing of this appliance, you have the following options:

- Dispose of the appliance at a designated municipal electronic waste collection facility.
- When buying a new appliance, the retailer will receive the old appliance free of charge.
- The manufacturer will receive the old appliance free of charge.
- Sell the appliance to certified scrap metal dealers.

Special notice

Disposing of this appliance in the forest or other natural surroundings endangers your health and is bad for the environment. Hazardous substances may leak into the ground water and enter the food chain.

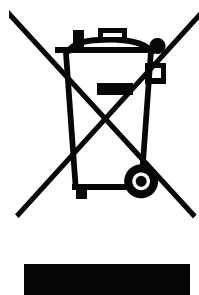



MIRCOOL®

COMFORT MADE SIMPLE

DIY® Multi-Zone

The design and specifications of this product and/or manual are subject to change without prior notice. Consult with the sales agency or manufacturer for details.