

Ignition transformers TZI, TGI

TECHNICAL INFORMATION

- Electrical ignition of gas burners
- Ignition and burner control with a single electrode possible
- TZI 7,5-20/33R complies with CSA



Contents

Contents	2
1 Application	3
1.1 Double-electrode operation	4
1.2 Single-electrode operation	4
2 Certification	5
3 Function	6
4 Selection	7
4.1 Type code	7
5 Project planning information	8
5.1 Operation	8
5.2 Installation	8
5.3 Cable selection	8
5.3.1 Ignition cable	8
5.4 Reduction of EMC, wiring	9
5.5 Single-electrode operation	9
5.6 Intermittent operation/Star electrodes	9
5.7 Duty cycle	10
6 Accessories	11
6.1 High-voltage cable	11
6.2 Radio interference suppressed terminal boots	11
7 Technical data	12
7.1 Dimensions	13
Fore more information	14

1 Application



*TZI 5-15/100, TZI 7-25/20,
TZI 7,5-12/100, TZI 7,5-20/33*



TGI

Ignition transformers TZI and TGI are designed for high-voltage spark ignition of gas burners and gas-ignited or directly ignited oil burners. The ignition transformers can also be used on burners with single-electrode operation; the ignition current and ionization current flow over a common

electrode. The ignition transformer TZI must be mounted in a housing, e.g. in a control cabinet. It fulfils the requirements for enclosure IP 00. Ignition transformer TGI in its die-cast aluminium housing meets the requirements for enclosure IP 54. It is suitable for on-site mounting near the burner.



Bogie hearth forging furnace in the metallurgical industry



Intermittent shuttle kiln in the ceramics industry



Walking beam furnace with overhead firing

1.1 Double-electrode operation

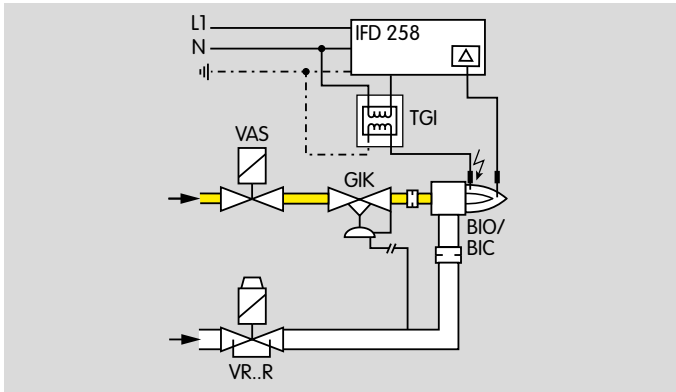

Ignition using spark electrode

Ignition transformer TGI is supplied with voltage via the automatic burner control unit IFD 258. The ignition transformer generates a high voltage. This high voltage creates ignition sparks between the spark electrode and burner ground.

After the burner start, a current flows via the flame rod for flame control.

1.2 Single-electrode operation

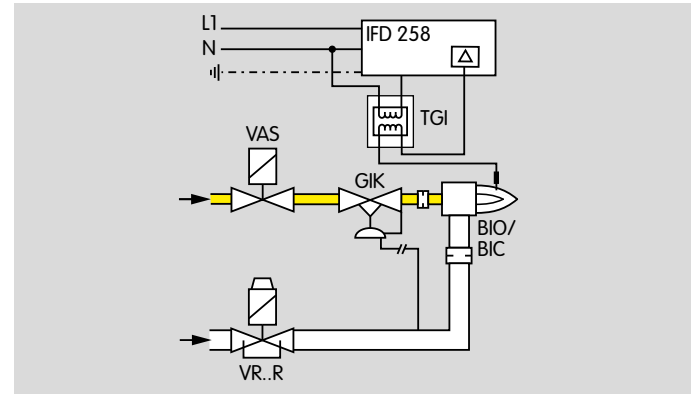

Ignition using a spark electrode and flame rod.

After burner start, a flame control current flows via the same electrode that is also used for ignition.

2 Certification

Ignition transformers TZI and TGI are built for applications pursuant to the Machinery Directive 2006/42/EC.

TZI 7,5-20/33R: CSA approved



Canadian Standards Association – CSA C22.2 No. 13-1962,
www.csagroup.org.

3 Function

Connection diagrams

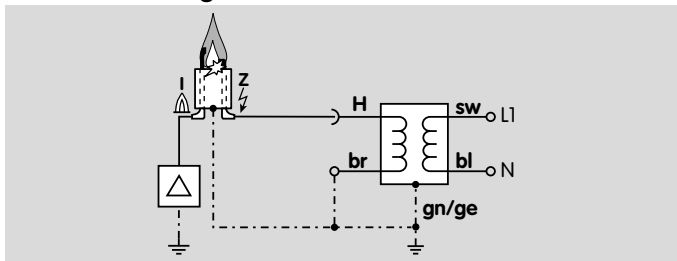

Ignition: double-electrode operation

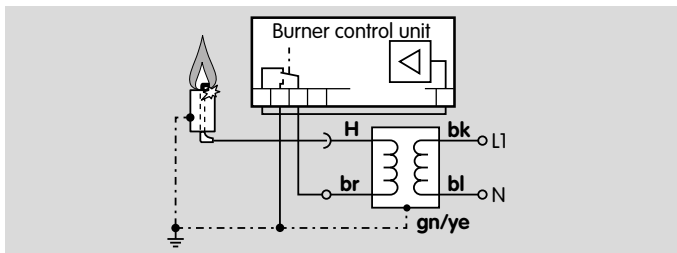

Ignition: single-electrode operation

Single-electrode operation is possible only in conjunction with suitable automatic burner control units. The switchover between ignition and monitoring is performed by the automatic burner control unit.

High-voltage connection

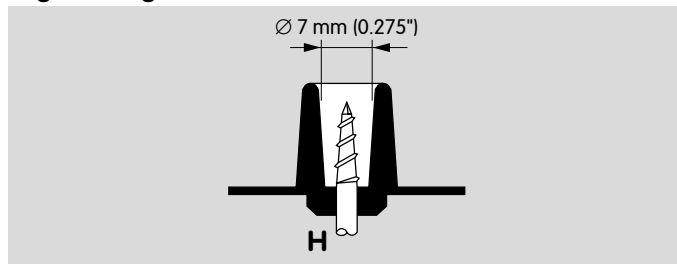

Cut end of high-voltage cable is inserted into the shroud and screwed onto the wood screw.

Legend

H	High-voltage connection
br	Connection cable brown
bk	Connection cable black
bl	Connection cable blue
gn/ye	Connection cable green/yellow

4 Selection

Ignition transformers TZI and enclosed ignition transformers TGI can be supplied for mains voltages of 115 V or 230 V.

4.1 Type code

TZI	Ignition transformer
TGI	Ignition transformer, enclosed
5	5 kV high voltage
7	7 kV high voltage
7,5	7.5 kV high voltage
-12	Output current: 12 mA at 50 Hz (9 mA at 60 Hz)
-15	Output current: 15 mA at 50 Hz (11 mA at 60 Hz)
-20	Output current: 20 mA at 50 Hz (15 mA at 60 Hz)
-25	Output current: 25 mA at 50 Hz (18 mA at 60 Hz)
/20	20% duty cycle
/33	33% duty cycle
/100	100% duty cycle
R	Mains voltage: 115 V AC
W	Mains voltage: 230 V AC

5 Project planning information

5.1 Operation

The ignition transformers are suitable only for applications for igniting gas burners and gas-ignited or directly ignited oil burners. An automatic burner control unit with integrated fuse (max. 4 A) must be provided to activate the ignition transformers. Do not operate the transformers when no ignition sparks are created (distance between spark electrode and burner ground = 2 ± 0.5 mm). The duty cycle and the ambient temperature must not exceed the permitted limits.

5.2 Installation

Installation position for TZI and TGI: install with the connections facing down. Position the ignition transformer right next to the burner (recommended ignition cable length: max. 5 m, recommended < 1 m).

TZI

The length of the mains cable is approx. 410 mm.
Fix the ignition transformer in a housing or control cabinet.

5.3 Cable selection

Use mains cable suitable for the type of operation and complying with local regulations.

Install an equipotential bond (4 mm², compliant with local regulations) between burner and ignition transformer.

TGI

The TGI housing has two A/F 27 cable glands with double seal inserts for two cables up to 7 mm in diameter. A seal

insert for 10 to 14 mm is enclosed and can be used in the A/F 27 cable gland, see page 13 (Dimensions).

5.3.1 Ignition cable

For the ignition cable, use a high-voltage cable, see page 11 (High-voltage cable). The ignition capacity is lower when using a screened ignition cable.

Ignition cable length:

Recommended < 1 m, max. 5 m. The longer the ignition cable, the lower the ignition capacity.

Use radio interference suppressed terminal boots only on the burner (with 1 k Ω resistor), see page 11 (Radio interference suppressed terminal boots).

5.4 Reduction of EMC, wiring

External electrical interference must be avoided.

Lay cables individually and, if possible, not in a metal conduit.

Do not lay UV/ionization cable and ignition cable together and lay them as far apart as possible.

Screw the ignition cable securely into the high-voltage connection **H** on the ignition transformer and run to the burner by the shortest possible route.

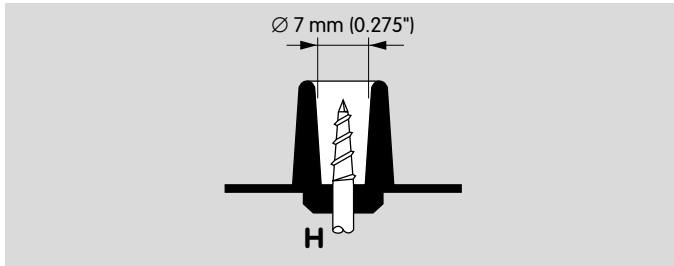

Use radio interference suppressed terminal boots only on the burner (with 1 k Ω resistor), see page 11 (Radio interference suppressed terminal boots).

5.5 Single-electrode operation

Single-electrode operation is possible only in conjunction with suitable automatic burner control units.

For single-electrode operation, wire an equipotential bond between the burner and the automatic burner control unit.

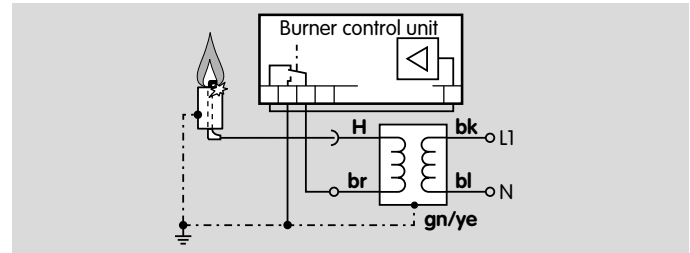

Ensure that the wiring has been done correctly, otherwise the connected units will be damaged.

5.6 Intermittent operation/Star electrodes

We recommend using 7.5 kV ignition transformers for On/Off intermittent operation or when using burners with star electrodes.

5.7 Duty cycle

The duty cycle indicates for how long the ignition transformer can be switched on within 180 s, without it being overloaded.

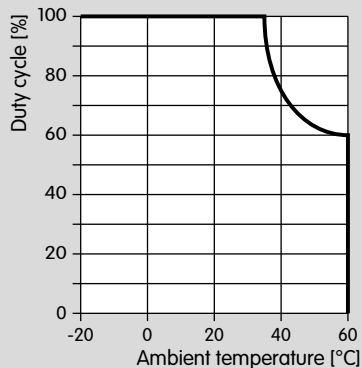

For ignition transformers, the duty cycle is dependent on the ambient temperature.

TZI/TGI duty cycle in %, see page 12 (Technical data).

Converting the duty cycle into seconds:

$$\text{Duty cycle [s]} = \frac{\text{Duty cycle [\%]} \times 180 \text{ s}}{100\%}$$

Example

Ignition transformer TZI 7-25/20W with a duty cycle of 20% for an ambient temperature of -20 to +35°C.

$$\text{Duty cycle} = \frac{20 \text{ [\%]} \times 180 \text{ s}}{100\%} = 36 \text{ s}$$

In an ambient temperature of -20 to +35°C, this results in a maximum duty cycle of 36 s within 180 s for the ignition transformer.

For an automatic burner control unit with an ignition time $t_z = 6 \text{ s}$, for example, the resultant timing cycle is a maximum of 2 ignitions per minute.

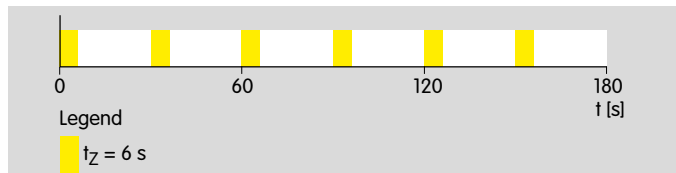

6 Accessories

6.1 High-voltage cable

FZLSi 1/7 -50°C (-58°F) to +180°C (+356°F),

Order No.: 04250410,

FZLK 1/7 -5°C (23°F) to +80°C (176°F),

Order No.: 04250409.

6.2 Radio interference suppressed terminal boots

Right-angle terminal boot, 4 mm (0.16 inch), interference-suppressed,

Order No. 04115308.

Straight terminal boot, 4 mm (0.16 inch), interference-suppressed,

Order No. 04115307.

Straight terminal boot, 6 mm (0.2 inch), interference-suppressed,

Order No. 04115306.

7 Technical data

Type	Input			Output			Duty cycle**	Enclosure	Weight
	V AC	Hz*	A*	V	mA*		%		
TZI 5-15/100W	230	50 (60)	0.45 (0.35)	5000	15 (11)		100	IP 00	1.5
TZI 7-25/20W	230	50 (60)	1.1 (0.8)	7000	25 (18)		20	IP 00	1.5
TZI 7,5-12/100W	230	50 (60)	0.6 (0.45)	7500	12 (9)		100	IP 00	2
TZI 7,5-20/33W	230	50 (60)	0.9 (0.7)	7500	20 (15)		33	IP 00	2
TZI 5-15/20R	115	50 (60)	1 (0.7)	5000	15 (11)		20	IP 00	0.9
TZI 5-15/100R	115	50 (60)	0.9 (0.7)	5000	15 (11)		100	IP 00	1.5
TZI 7-25/20R	115	50 (60)	2.2 (1.6)	7000	25 (18)		20	IP 00	1.5
TZI 7,5-12/100R	115	50 (60)	1.2 (0.9)	7500	12 (9)		100	IP 00	2
TZI 7,5-20/33R	115	50 (60)	1.8 (1.35)	7500	20 (15)		33	IP 00	2
TGI 5-15/100W	230	50 (60)	0.45 (0.35)	5000	15 (11)		100	IP 54	3
TGI 7-25/20W	230	50 (60)	1.1 (0.8)	7000	25 (18)		20	IP 54	3
TGI 7,5-12/100W	230	50 (60)	0.6 (0.45)	7500	12 (9)		100	IP 54	3.5
TGI 7,5-20/33W	230	50 (60)	0.9 (0.7)	7500	20 (15)		33	IP 54	3.5
TGI 5-15/100R	115	50 (60)	0.9 (0.7)	5000	15 (11)		100	IP 54	3
TGI 7-25/20R	115	50 (60)	2.2 (1.6)	7000	25 (18)		20	IP 54	3
TGI 7,5-12/100R	115	50 (60)	1.2 (0.9)	7500	12 (9)		100	IP 54	3.5
TGI 7,5-20/33R	115	50 (60)	1.8 (1.35)	7500	20 (15)		33	IP 54	3.5

* Values in brackets apply to 60 Hz.

** At -20 to +35°C. Converting the duty cycle into seconds, see page 10 (Duty cycle).

Ambient temperature: -20 to +60°C.

7.1 Dimensions

TZI

Length of connection cable: approx. 410 mm

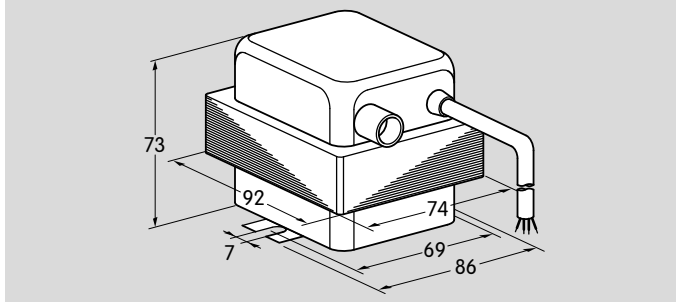

TZI 5-15/100, TZI 7-25/20

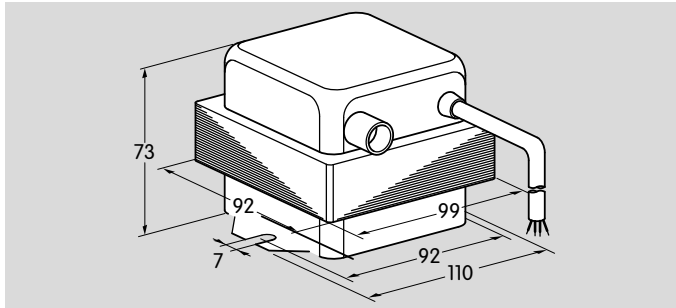

TZI 7,5-12/100, TZI 7,5-20/33

TGI

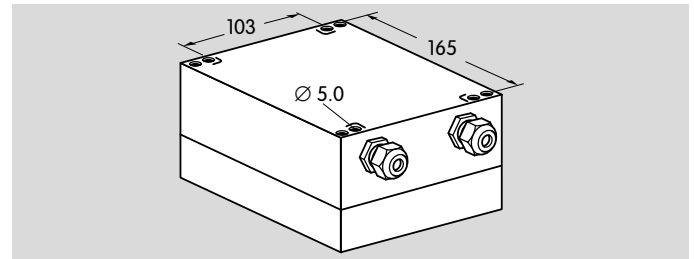
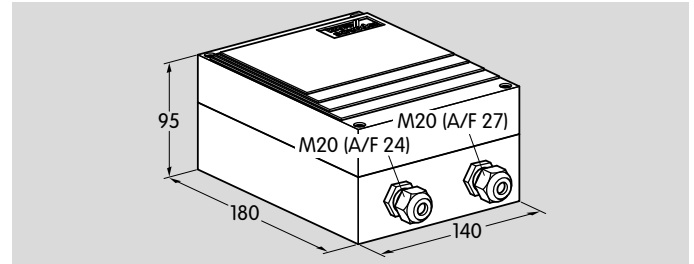

Fore more information

The Honeywell Thermal Solutions family of products includes Honeywell Combustion Safety, Eclipse, Exothermics, Hauck, Kromschroder and Maxon. To learn more about our products, visit ThermalSolutions.honeywell.com or contact your Honeywell Sales Engineer.

Elster GmbH
Strotheweg 1, D-49504 Lotte
T +49 541 1214-0
hts.lotte@honeywell.com
www.kromschroeder.com

© 2020 Elster GmbH

We reserve the right to make technical modifications in the interests of progress.

