

Pressure switch mechanical Model PSM-530

WIKA data sheet PSM-530



Applications

- Automatic start/stop of compressors
- Automatic start/stop of water pumps

Special features

- Robust design
- Triple pole cut-in/cut-out
- Diaphragm sensor
- Manual on/off



Fig. top: Pressure switch mechanical, model PSM-530

Fig. bottom: Pressure switch mechanical with relief valve, model PSM-530

Description

Model PSM-530 pressure switches are essentially designed for on-off pressure control applications such as air compressors or water pumps to control their working between the minimum and maximum setting values. At the maximum setting value, pressure switch contacts open and stops the motor. At the minimum value, pressure switch contacts close and start the motor.

A diaphragm senses the change in pressure and actuates a triple pole contact switch, which enables control of 3-phase motors.

The set point (cut-out pressure) and reset point (cut-in pressure) are adjusted by a range screw and a differential screw.

A pressure relief valve (unloader valve) to relieve the pressure locked at the compressor cylinder head is available in model PSM-530.

Standard version

Switch enclosure

Cover: ABS, plastic
Housing: Steel, powder coated

Repeatability

±2 % of full scale value

Permissible ambient temperature

-40 °C ... +70 °C

Permissible medium temperature

-20 °C ... +70 °C

Process connection

- G 1/2 (F)
- G 1/4 (F)
- Optional process connection available on request

Measuring element

Nitrile diaphragm (NBR) fabric interlaid

Pressure connector

Die cast aluminium

Gasket

Process connection: Nitrile
Cover: Silicone

Switch contacts

Triple pole single throw (TPST) contact system

Switching function

Normally closed contacts

On-off differential

Adjustable

Manual on/off ★

Standard

Electrical rating

AC-15: 9A, 440V

Electrical entry

Rubber grommet suitable for Ø 6 ... 14 mm cable

Ingress protection

IP44 (EN 60529)

Mounting

Direct online

Pressure relief valve (only PSM-530-9U, PSM-530-15U)

1/4" flare connection with nut

Conformity

Generally to BS:6134:1991

Ordering matrix

Model	Range in bar	Settable Range in bar	Differential in bar		Max. pressure in bar	Pressure relief valve
			Min.	Max.		
PSM-530-4	1 ... 4	1.7 ... 4	0.7	3	8	×
PSM-530-9	2.5 ... 9.5	4.3 ... 9.5	1.8	7	20	×
PSM-530-15	7 ... 15	9.3 ... 15	2.3	7	20	×
PSM-530-9U	2.5 ... 9.5	4.3 ... 9.5	1.8	7	20	✓
PSM-530-15U	7 ... 15	9.3 ... 15	2.3	7	20	✓

Note:

★ Add suffix "X" in the model number if manual switching option is not required. (e. g. PSM-530-9U to PSM-530-9UX)

Dimensions in mm

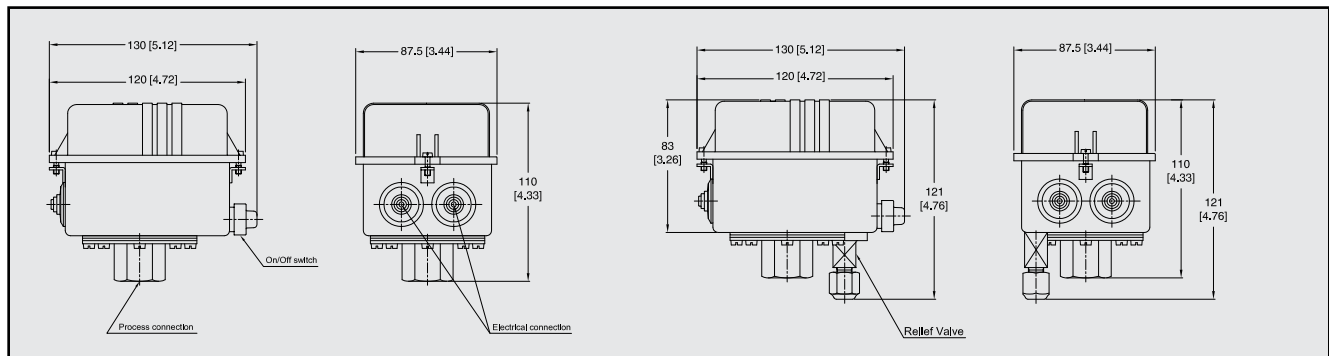

Ordering information

Model / Optional process connection

© 2021 WIKA Instruments India Pvt. Ltd., all rights reserved.
The specifications given in this document represent the state of engineering at the time of publishing.
We reserve the right to make modifications to the specifications and materials.