

SLN 700 SmartLine Non-Contact Radar Level Specification

34-SL-03-06, January 2020



Introduction

Part of the SmartLine® family of products, the SLN 700 is a high performance 80 GHz non-contact radar level transmitter offering high accuracy, stability over a wide range of level applications. SmartLine SLN 700 level transmitters are an ideal solution for demanding process level needs, with easy-to-use and low-maintenance character.

The SmartLine family is also fully tested and compliant with Experion® PKS, providing the highest level of compatibility assurance and integration capabilities. SmartLine easily meets the most demanding needs for level measurement applications.

A SmartLine Application and Validation Tool provides a new level of user experience and increases engineering productivity.



Figure 1 —SLN700 Non-Contact Radar Level transmitter

Best in Class Features:

- 80 GHz FMCW technology
- Narrow beam, small blind zone & accurate measurement
- Immunity to temperature, pressure, most obstacles and dust
- False echo suppression option
- Easy setup, no dielectric constant dependence
- Small antenna size fits most process: easy to install
- High resolution: better accuracy and process detail
- Measuring range: up to 30 m (liquids) / 120 m (solids)
- Accuracy ± 2 mm
- Process Temperature range: -40 to 200 °C
- Process Pressure range: -1 to 25 bar
- Operating voltage: 12 to 30 V DC
- Output signal: 4 - 20 mA & HART®

Description

The SmartLine 80 GHz Non-Contact Radar Level transmitter utilizes Frequency Modulated Continuous Wave (FMCW) technology which has greater sensitivity and accuracy for level measuring applications.

Unique Out-of-the-Box, Full User Experience¹

The specification of the correct level transmitter for the level measurement is one of the root causes for many common field failure modes. This user experience is enhanced with the unique SmartLine Application and Validation Tool (AVT) found at <https://config.honeywellsmartline.com/>. This allows users to specify their tank level application and the options desired for their level transmitter. The AVT intelligently guides the user through the engineering process and electronically captures and documents the choices and inputs.

In addition to serving as engineering documentation, the AVT output also serves as input to the Honeywell order management system, thus ensuring correct input of the transmitter model. The additional advantage is a transmitter with configuration parameters already specified to match the targeted tank application. Errors are eliminated and the engineering effort is preserved from start to finish.

The SmartLine Application and Validation Tool also allows users to collaboratively use and share the active session with any web connected colleague or expert. This interactive, collaborative capability eliminates roadblocks and delays. Users can access resources to help start and finish the engineering task in a single effort. This online tool also dynamically reformats the user interface to display correctly on an IOS or Android™ device.

¹ will be available soon.

Diagnostics

SmartLine transmitters all offer digitally accessible diagnostics which aid in providing advanced warning of possible failure events, minimizing unplanned shutdowns, providing **lower overall operational costs**

System Integration

- SmartLine communications protocols all meet the most current published standards for HART®
- Integration with Honeywell's Experion® PKS offers the following unique advantages.
 - FDM Plant Area Views with Health summaries
 - The SLN series is Experion tested to provide the highest level of compatibility assurance.

Unique Indication/Display Options

The SmartLine SLN series level transmitter's modular design accommodates a unique advanced graphics LCD display.



Figure 2: Advanced Graphics LCD Display Features

- Display modular can be added or removed in the field
- 128 by 64 dot matrix graphics display
- Large PV font format supported. Echo stem plots with Distance to Product and Distance to Interface Configurable screen
- The Display supports English and Chinese languages.

Modular Design

To help contain maintenance and inventory costs, all SLN series transmitters are modular in design supporting the user's ability to change electronic modules without affecting overall performance. Electronic modules may be swapped with another electronics module without losing in-tolerance performance characteristics

With no performance effects, Honeywell's unique modularity results in **lower inventory needs and lower overall operating costs.**

Configuration Tools

Integral Four Button Configuration Option

Suitable for all electrical and environmental requirements, SmartLine offers the ability to configure the transmitter and display via four buttons.

HandHeld Configuration

SmartLine transmitters feature two-way communication and configuration capability between the operator and the transmitter. This is accomplished via Honeywell's field-rated Multiple Communication Configurator.

FDM and FDM Express

Honeywell's Field Device Manager (FDM) Software and FDM Express are available for managing HART® device configurations.

Product Family

SLN700L-82 (80 GHz)

for liquids in corrosive process applications



The SLN700L-82 is an 80 GHz FMCW radar transmitter for continuous level measurement of liquids under different process conditions. The excellent beam focusing can provide accurate and reliable measurement in regular or strongly corrosive liquids.

The SLN700L-82 can measure in process conditions with temperatures up to +200°C and pressures up to 25 bar. The antenna options permit to measure distances up to 30 m. It offers an extensive choice of flanged process connections from DN50 to DN150.

SLN700L-83 (80 GHz)

for liquids in process applications for small vessels



The SLN700L-83 is an 80 GHz FMCW radar transmitter for continuous level measurement of liquids under different process conditions, especially in small vessels. The excellent beam focusing can provide accurate and reliable measurement from basic process to mild corrosive liquids, especially for small vessels.

The SLN700L-83 can measure in process conditions with temperatures up to +200°C and pressures up to 25 bar. The antenna options permit to measure distances up to 30 m. It offers an extensive choice of threaded process connections from 3/4" to 3".

SLN700S-87 (80 GHz)

for solids in process applications



The SLN700S-87 is an 80 GHz FMCW radar transmitter for continuous level measurement of solids under different process conditions. The excellent beam focusing can provide accurate and reliable measurement for most powder or bulk solids applications in storage vessels. Options for air purge or dust shield options optimize sensor performance in dusty conditions.

The SLN700S-87 can measure in process conditions with temperatures up to +200°C and pressures up to 25 bar. The antenna options permit to measure distances up to 120 m. It offers an extensive choice of flanged process connections from DN100 to DN150.

General Specifications

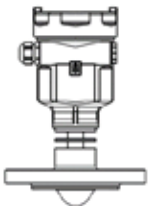
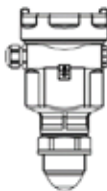
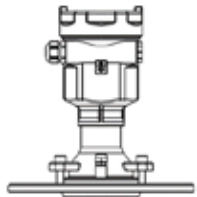
	SLN700L-82	SLN700L-83	SLN700S-87
			
Applications:	Liquids Suitable for the strong corrosive liquids, vapours / foams	Liquids Suitable for mildly corrosive liquids; small vessels	Solids Storage vessel/process vessel or high dust environment
Measurement range:	0~30 m	0~10 m (SLN700L-83A) 0~30 m (SLN700L-83B/C/D/E)	0~120 m
Measurement accuracy:	±2 mm		±5mm
Process temperature	(-40~150) °C (-40~200) °C	(-40~130) °C (-40~200) °C	(-40~130) °C (-40~200) °C
Process pressure	(-0.1~2.5) MPa		(-0.1~0.3) MPa
Antenna form: (See Antenna)	SLN700L-82A/B/C/D	SLN700L-83A/B/C/D/E	SLN700S-87A/B/C/D
Antenna + Lens material: (See Antenna)	316L+FEP 316L+PTFE	316L+PTFE	316L+PP 316L+PEEK
Process Connection (See Antenna)	Flange	Thread	Flange
Seal Material	FKM	FFKM	FKM
Frequency:	77-81 GHz		
Signal output:	4-20 mA & HART®		
Power supply:	2-wire (12~30) V DC		
Housing Material:	Polyester-coated aluminium		
Weight	SLN700L-82: approx. 5.1 to 18.4 kg SLN700L-83: approx. 1.8 to 3.5 kg SLN700S-87: approx. 4.8 to 8.6 kg		
Ingress Protection level	IP67		
Unmeasurable area	End of antenna		
Measurement interval	approx. 1 s		
Adjust time	approx. 3 s		
Display resolution	1 mm		
Display	128 × 64 pixels, with 4-button keypad		

Operating Conditions – All Models

Parameter	Description	
Environmental Operating temperature¹	Device Operating range: -25 to 80 °C Display operating range: -20 to 80 °C	
Temperature for storage and transport	-40 to +80 °C	
Relative humidity	<95%	
Power Supply 2-wire	Standard type	(12~30) V DC
	Intrinsically safe	(12~30) V DC
	Power consumption	max.22.5 mA
	Ripples are allowed	
	– <100Hz	U _{ss} <1 V
	– (100~100K)Hz	U _{ss} <10 mV
Cable parameters	Cable entry/plug	M20x1.5/ 1/2'NPT cable entry, and M20x1.5/ 1/2'NPT blind plug
	Spring collecting terminals	Used for conductor with cross section of 2.5 mm ²
Output parameter	Output signal	(4-20) mA/HART®
	Resolution	0.3 μA
	-2-wire load resistance	Refer to Figure 3

¹ The ambient temperature limit for intrinsic safety differs. See section on Hazardous Location Approvals.

2-wire load resistance

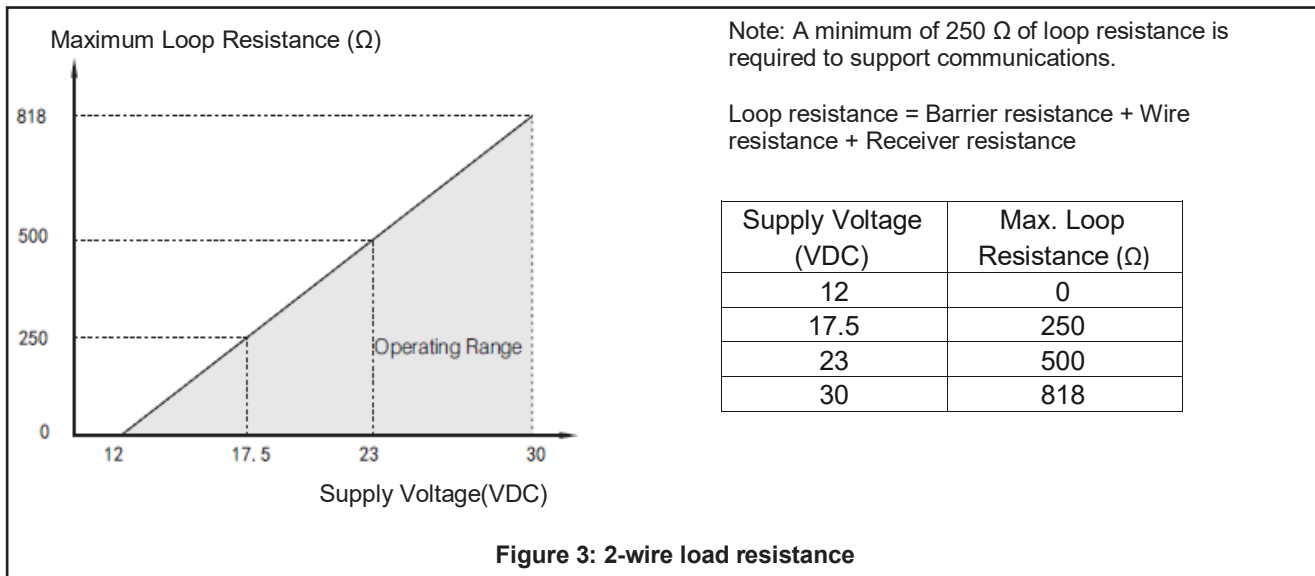

Performance Under Rated Conditions – All Models

Parameter	Description
Analog Output	Two-wire, 4 to 20 mA
Digital Communications:	HART [®] 7 protocol
Output Failure Modes	Compliance: Honeywell Standard: Normal Limits: 3.8 – 20.8 mA Failure Mode: ≤ 3.6 mA and ≥ 21.0 mA
Measurement accuracy	Refer to figure on page 7
Temperature drift	±2 mm/10 K
Repeatability	±1 mm
Dielectric constant (minimum)	1.4
Electromagnetic Compatibility and Radio Equipment	EN 301 489-1 V2.2.0, EN 301 489-3 V2.1.1, EN 302 729 V2.1.1, EN 302 372 V2.1.1, EN 62311:2008
Electrical Safety	EN 61010-1:2010
Vibration-proof	Mechanical shock 10 m/s ² , 10-150 Hz

Measurement accuracy under reference conditions

Measuring distance from lower edge of flange or thread



SLN700L-82A/B/C/D	
Lens antenna	Beam Angle
DN50 (SLN700L-82A/B)	6°
DN80 (SLN700L-82C/D)	3°





SLN700L-83A	
Lens antenna	Beam Angle
¾" (SLN700L-83A)	14°

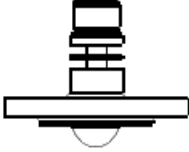
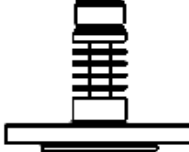

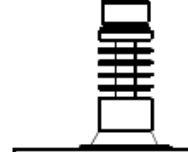
SLN700L-83B/C/D/E	
Lens antenna	Beam Angle
1½" (SLN700L-83B/C)	6°
3" (SLN700L-83D/E)	3°

SLN700S-87A/B/C/D	
Lens antenna	Beam Angle
DN80 (SLN700L-87A/B/C/D)	4°

Antenna

				
No.	SLN700L-82A	SLN700L-82B	SLN700L-82C	SLN700L-82D
Material	316L+FEP 316L+PTFE	316L+FEP 316L+PTFE	316L+FEP 316L+PTFE	316L+FEP 316L+PTFE
Process Connection	DN50 DN80 DN100	DN50 DN80 DN100 DN150	DN80 DN100 DN125 DN150	DN80 DN100 DN125
Features	Anti-corrosion High Pressure Single radiator 150 °C	Anti-corrosion High Pressure Multi-fin radiator 200 °C	Anti-corrosion High Pressure Single radiator 150°C	Anti-corrosion High Pressure Multi-fin radiator 200 °C

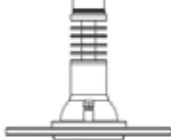
					
No.	SLN700L-83A	SLN700L-83B	SLN700L-83C	SLN700L-83D	SLN700L-83E
Material	316L+PTFE	316L+PTFE	316L+PTFE	316L+PTFE	316L+PTFE
Process Connection	Thread G $\frac{3}{4}$ A Thread $\frac{3}{4}$ NPT	Thread G1 $\frac{1}{2}$ A Thread 1 $\frac{1}{2}$ NPT	Thread G1 $\frac{1}{2}$ A Thread 1 $\frac{1}{2}$ NPT	Thread G3 A	Thread G3 A
Features	Anti-corrosion	Anti-corrosion	Anti-corrosion	Anti-corrosion	Anti-corrosion

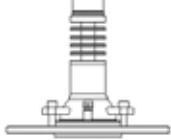
				
No.	SLN700S-87A	SLN700S-87B	SLN700S-87C	SLN700S-87D
Material	316L+PP/ 316L+PEEK	316L+PEEK	316L+PP/ 316L+PEEK	316L+PEEK
Process Connection	DN100 DN125 DN150	DN100 DN125 DN150	DN100 DN125 DN150	DN100 DN125 DN150
Features	Thread/purging Micro Pressure 130 °C	Thread/purging Micro Pressure with Radiator 200 °C	Universal/purging Atmospheric 130 °C	Universal/purging Atmospheric with Radiator 200 °C

Housing Dimensions

AG type housing

Material: Polyester Powder Coated Aluminum

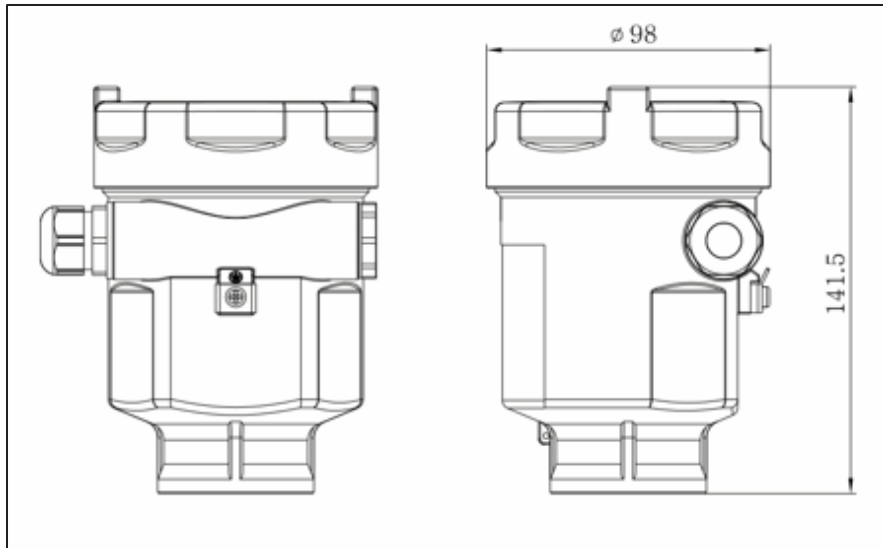

Figure 4: AG type housing

Dimensional Drawings

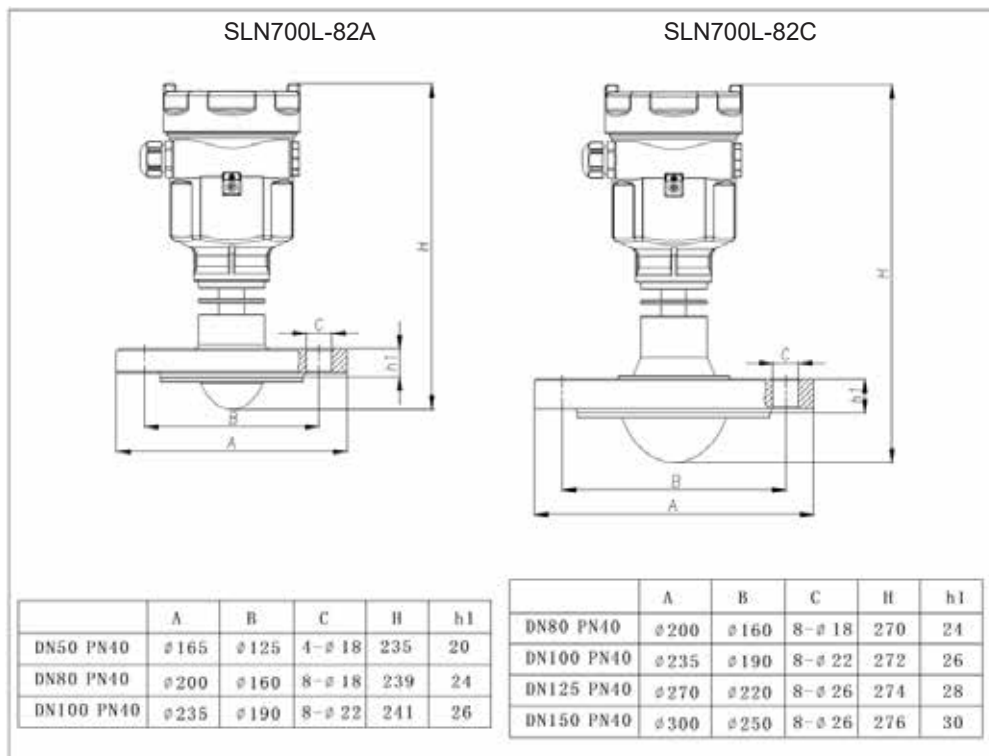

Figure 5: SLN700L-82A/C

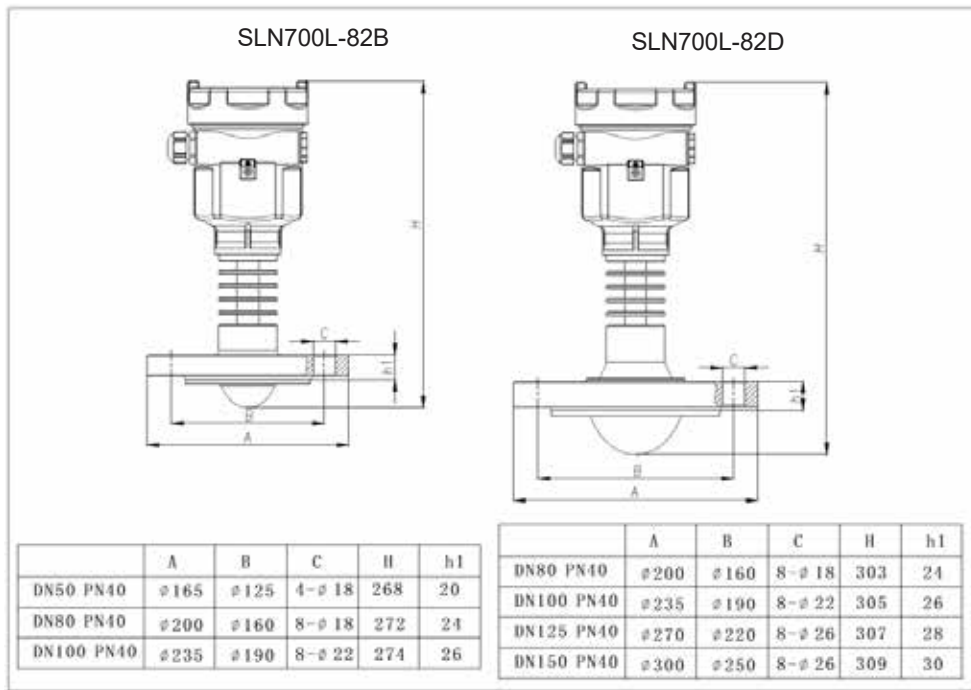

Figure 6: SLN700L-82B/D

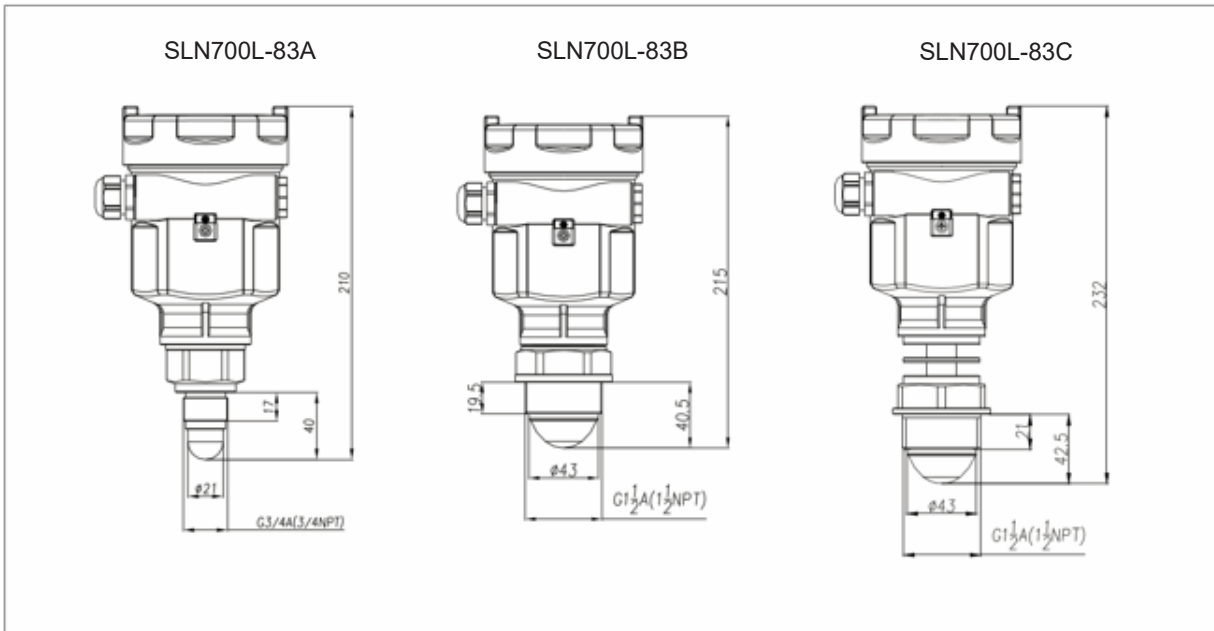

Figure 7: SLN700L-83A/B/C

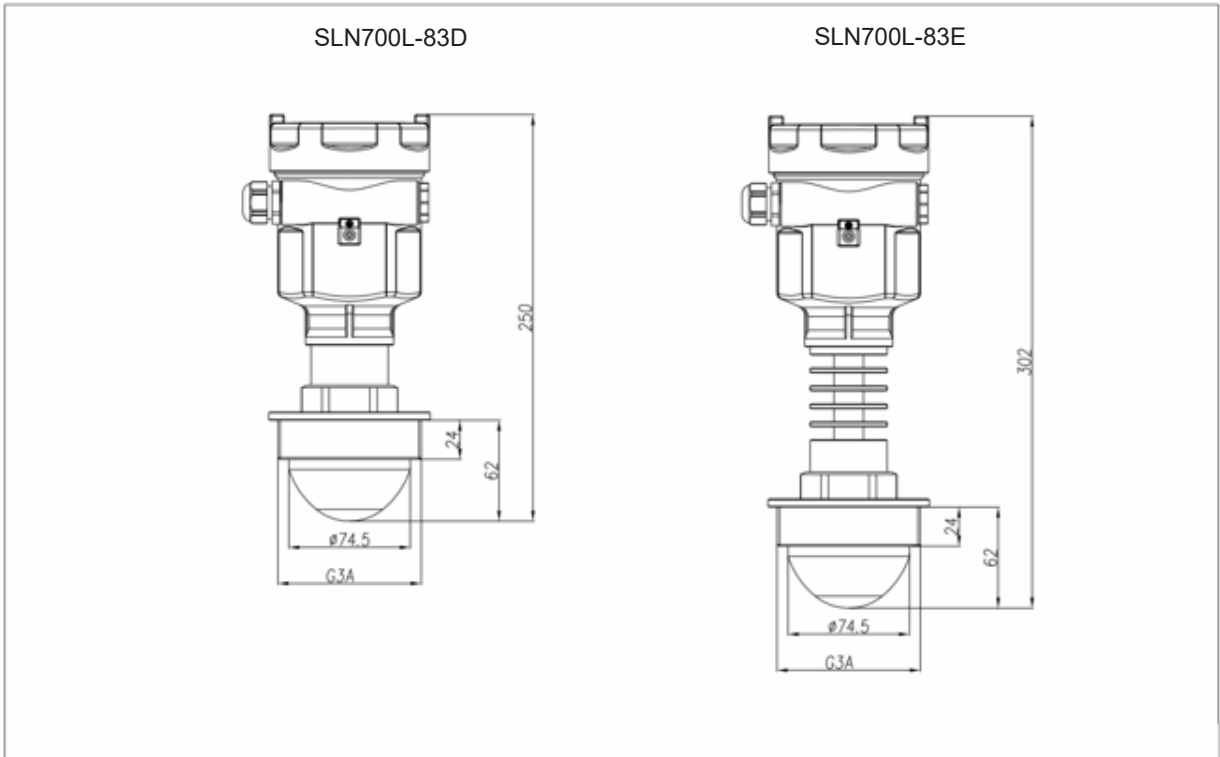

Figure 8: SLN700L-83D/E

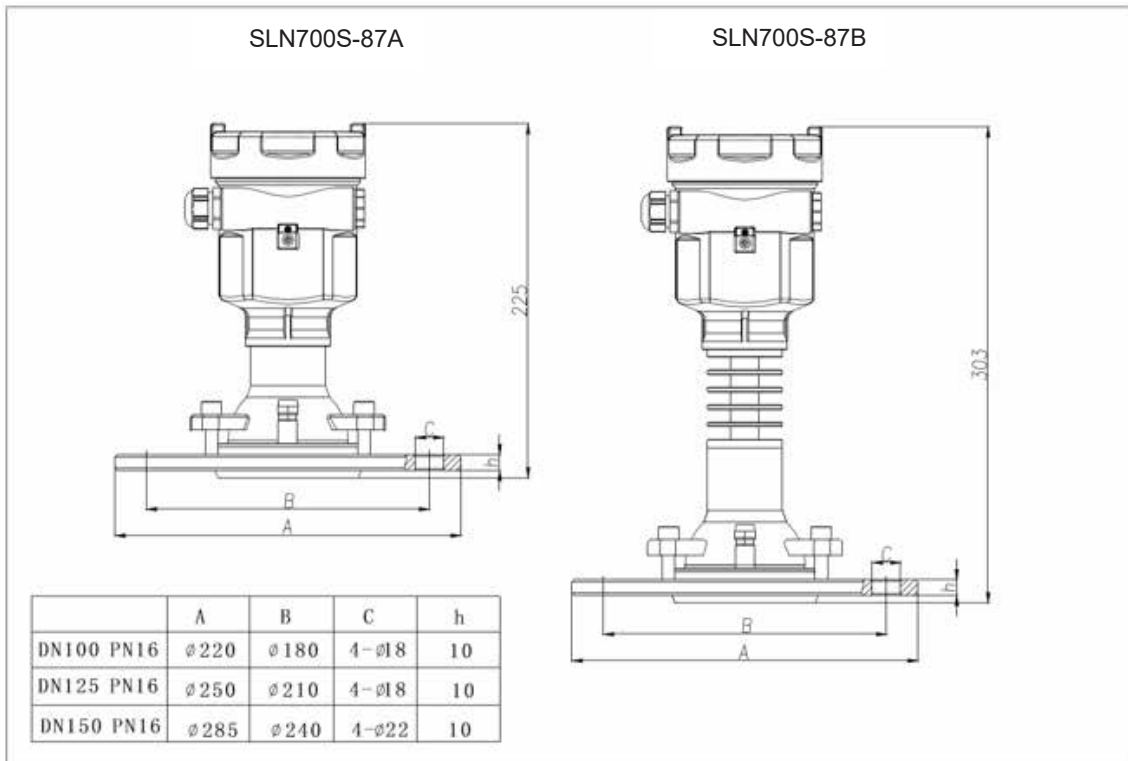

Figure 9: SLN700S-87A/B

Hazardous Location Approvals

AGENCY	TYPE OF PROTECTION
IECEX	Intrinsically Safe: Ex ia IIC T6...T2 Ga Ex ia IIIC T76°C...T146°C Da
ATEX	Intrinsically Safe: II 1 G Ex ia IIC T6...T2 Ga II 1 D Ex ia IIIC T76°C...T146°C Da

Ambient Temperature (°C)	Process Temperature (°C)	Temperature Rating
-40 to 70	-40 to 80	T6
	-40 to 95	T5
	-40 to 130	T4
	-40 to 195	T3
	-40 to 200	T2

Intrinsic Safety Entity Parameter	Value
Ui	30.6V
Ii	131mA
Pi	1.0W
Ci	0uF
Li	102uH

Model Selection Guide

Model Selection Guides are subject to change and are inserted into the specifications as guidance only.

Model SLN7XX Series Liquid/Solid Measurement Smartline Non Contact Radar Level Transmitter

Model Selection Guide

34-SL-16-20

Issue 1

Instructions

- Select the desired Key Number. The arrow to the right marks the selection available.
- Make one selection from each Table (I, II and IX) using the column below the proper arrow.
- A(●) denotes unrestricted availability. Aletter denotes restricted availability.
- Restrictions follow Table IX.

Key Number Table 1 Table 2 Table 3 Table 4 Table 5 Table 6 Table 7 Table 8 Table 9
 |SLN700_ | - | _ _ _ _ _ | - | _ _ _ _ _ | - | _ _ _ _ _ | - | _ _ _ _ _ | - | _ _ _ _ _ | - | _ _ _ _ _ | - | _ _ _ _ _ | - | _ _ _ _ _ | - | _ _ _ _ _ |

KEY NUMBER	Application	Selection	Availability
	Liquid Level Measurement	SLN700L	↓
	Solid Level Measurement	SLN700S	↓

TABLE I	Antenna and Material Selections						Selection	L	S	
	Antenna Type	Process temperature	Process Pressure	Lens Diameter	Options	Range				
a. Antenna type and materials	Flange with encapsulated antenna	-40 to +150 °C (-40 to +302 °F)	-1...25 barg (-14.5...362 psig)	50mm		30m	82A__	•		
		-40 to +200 deg C (-40 to +392 F)	-1...25 barg (-14.5...362 psig)	50mm		30m	82B__	•		
		-40 to +150 °C (-40 to +302 °F)	-1...25 barg (-14.5...362 psig)	80mm		30m	82C__	•		
		-40 to +200 deg C (-40 to +392 F)	-1...25 barg (-14.5...362 psig)	80mm		30m	82D__	•		
		-40 to +130 deg C (-40 to +266 F)	0...1 barg (0...14.5 psig)	80mm	Gimbal Flange	120m	87A__		•	
		-40 to +200 deg C (-40 to +392 F)	0...1 barg (0...14.5 psig)	80mm	Gimbal Flange	120m	87B__		•	
	Thread with integrated horn antenna	-40 to +130 deg C (-40 to +266 F)	-1...3 barg (-14.5...43.5 psig)	80mm		120m	87C__		•	
		-40 to +200 deg C (-40 to +392 F)	-1...3 barg (-14.5...43.5 psig)	80mm		120m	87D__		•	
		-40 to +130 deg C (-40 to +266 F)	-1...25 barg (-14.5...362 psig)	3/4"		10m	83A__	•		
		-40 to +130 deg C (-40 to +266 F)	-1...25 barg (-14.5...362 psig)	1½"		30m	83B__	•		
b. Lens materials		-40 to +200 deg C (-40 to +392 F)	-1...25 barg (-14.5...362 psig)	1½"		30m	83C__	•		
		-40 to +130 deg C (-40 to +266 F)	-1...25 barg (-14.5...362 psig)	3"		30m	83D__	•		
		-40 to +200 deg C (-40 to +392 F)	-1...25 barg (-14.5...362 psig)	3"		30m	83E__	•		
			PTFE (-40 to +200 deg C) FEP (-40 to +200 deg C) PEEK (-40 to +200 deg C) PP (-40 to +110 deg C)				___0 ___A ___B ___C		k a • •	
c. Seal materials						___0 ___A	• •	• •		
								FKM (-40 to +200 deg C) FFKM (-20 to +200 deg C)		

TABLE II	Connection Types	Material	Size	Rating	Selection	L	S		
		316L	2"	Class 150lb RF Class 300lb RF	AS2A AS2B	c c			
			3"	Class 150lb RF Class 300lb RF	AS3A AS3B	a a	•		
			4"	Class 150lb RF Class 300lb RF	AS4A AS4B	d d			
			6"	Class 150lb RF Class 300lb RF	AS6A AS6B	f f	•		
			8"	Class 150lb RF Class 300lb RF	AS8A AS8B	f f	•		
			Flanges	316L	DN50	DN50 PN40	DS5B	c	
					DN80	DN80 PN40	DS8B	a	
					DN100	DN100 PN40	DS1B	d	
						DN100 PN16	DS1A		•
					DN125	DN125 PN40	DS1M	f	
	DN125 PN16	DS1N					•		
	DN150	DN150 PN40	DS1Z	f					
		DN150 PN16	DS1Y		•				
	Threaded Fittings ISO228 and ANS	316L	3/4" NPT		NS7A	h			
			1 - 1/2" NPT		NS5A	m			
			G 3/4"		GS7A	h			
			G 1-1/2"		GS5A	m			
			G 3"		GS8A	n			

TABLE III	Agency Approvals (see data sheet for Approval Code Details)	Selection	L	S
Approvals	No Explosion Protection Approvals Required	0	j	•
	ATEX Intrinsicly Safe	C	•	•
	IECEX Intrinsicly Safe	D	•	•
	NEPSI Intrinsicly Safe	G	•	•

TABLE IV	ELECTRONICS SELECTIONS			Selection	L	S
a. Electronic Housing Material & Connection Type	Housing Material	Connection	Lightning Protection			
	Polyester Powder Coated Aluminum	1/2 NPT	None	A__	j	•
	Polyester Powder Coated Aluminum	M20	None	B__	j	•
b. Output/ Protocol	Analog Output		Digital Protocol			
	4-20mA dc		HART Protocol	_H_	•	•
c. Customer Interface Selections	Indicator	Zero, Span & Config Buttons	Languages			
	None	None	None	_0	•	•
	Advanced	Yes	EN, CH	_G	•	•

TABLE V	CONFIGURATION SELECTIONS			Selection	L	S
a. Diagnostics	Diagnostics					
	Standard Diagnostics			1___	•	•
b. Advanced Measurement	Interface Options					
	None - Standard Level			_0_	•	•
c. Output Limit, Failsafe & Write Protect Settings	Write Protect	Fail Mode	High & Low Output Limits ³			
	Disabled	High> 21.0mAdc	Honeywell Std (3.8 - 20.8 mAdc)	_1_	•	•
	Disabled	Low< 3.6mAdc	Honeywell Std (3.8 - 20.8 mAdc)	_2_	•	•
	Enabled	High> 21.0mAdc	Honeywell Std (3.8 - 20.8 mAdc)	_3_	•	•
	Enabled	Low< 3.6mAdc	Honeywell Std (3.8 - 20.8 mAdc)	_4_	•	•
	Enabled	N/A	N/A Fieldbus or Profibus	_5_		
Disabled	N/A	N/A Fieldbus or Profibus	_6_			
d. General	Factory Standard			_S	•	•

TABLE VI		CALIBRATION & ACCURACY SELECTIONS			Selection	
Accuracy and Calibration	Accuracy	Calibrated Range	Calibration Qty	A	•	•
	Std Accuracy (+/-2mm)	Factory Std	Single Range			

TABLE VII		ACCESSORY SELECTIONS			Selection	
a. Customer Tag	No customer tag			0	•	•
	One Wired Stainless Steel Tag (Up to 4 lines 26 char/line)			1	•	•
	Two Wired Stainless Steel Tag (Up to 4 lines 26 char/line)			2	•	•
b. Unassembled	No Conduit Plugs or Adapters Required			A0	•	•

TABLE VIII		OTHER Certifications & Options: (String in sequence comma delimited (XX, XX, XX,....))			Selection	
Certifications & Warranty	None			00	•	•
	Certificate of Conformance			F3	•	•
	Calibration Test Report & Certificate of Conformance			F1	•	•
	Extended Warranty Additional 1 year			01	•	•
	Extended Warranty Additional 2 years			02	•	•
	Extended Warranty Additional 3 years			03	•	•
	Extended Warranty Additional 4 years			04	•	•

TABLE IX		Manufacturing Specials			Selection	
Factory	Factory Identification			0000	•	•

MODEL RESTRICTIONS

Restriction Letter	Available Only with		Not Available with	
	Table	Selection(s)	Table	Selection(s)
a	la	82A, 82B, 82C, 82D, 89A, 89B		
c	la	82A, 82B		
d	la	82A, 82B, 82C, 82D		
e	la	83A, 83B, 83C, 83D, 83E		
f	la	82C, 82D		
h	la	83A		
j			la	89A, 89B
k	la	82A, 82B, 82C, 82D, 83A, 83B, 83C, 83D, 83E		
m	la	83B, 83C		
n	la	83E		
b	Select only one option from this group			

HART® is a registered trademark of HART Communication Foundation.
 FOUNDATION™ Fieldbus is a trademark of Fieldbus Foundation.
 Viton® is a registered trademark of DuPont Performance Elastomers.
 Teflon® is a registered trademark of DuPont.
 FM Approvals™ is a service mark of FM Global

FIELD INSTALLABLE REPLACEMENT PARTS

Description	Kit Number
NCR Level HART Electronics module for Liquids	50155577-501
NCR Level HART Electronics module for Solids	50155577-502
NCR Level Display module	50155578-501

Specifications are subject to change without notice.

Authorised Distributors

Futuristic Technologies

232, Sunrise Mall,
Near Swaminarayan Temple,
Mansi Circle, Vastrapur,
Ahmedabad - 380015, Gujarat, India

Cell : +91 9737977735
sales@futuristicclimatecontrols.in

www.futuristicclimatecontrols.in

34-SL-03-06
January 2020
©2020 Honeywell International Inc.

Honeywell