



GREYSTONE ENERGY SYSTEMS INC

DUCT HUMIDITY /TEMPERATURE TRANSMITTER RH210 Series

The RH210 series uses a highly accurate and reliable Thermoset Polymer based capacitance humidity sensor and Platinum RTD temperature sensor together with state-of-the-art digital linearization and temperature compensated circuitry to monitor humidity levels. The sensors are encapsulated in a 228.60 mm (9") long by 12.7 mm (0.5") diameter S/S probe. A 60 micron HDPE filter protects the sensor for contaminants.



SPECIFICATION:

Humidity Sensor Type:.....Thermoset polymer based capacitive
 Accuracy at 25°C:.....±2, 3, or 5% RH, (5% to 95% RH)
 Measurement Range:.....0 to 100% RH
 Temperature Dependence:.....±0.05% RH/ °C
 Hysteresis:.....±1.5% RH maximum
 Repeatability:.....±0.5% RH typical
 Linearity:.....±0.5% RH typical
 Stability:.....±1% RH typical at 50% RH in 5 yrs.
 Sensor Response Time:.....15 seconds typical
 Sensitivity:.....0.1% RH
 Temperature Sensor Type:.....C - 1000 Ω Platinum. IEC751, 385 Alpha, thin film, ±0.3°C @ 0°C
 L - 100 Ω Platinum. IEC751, 385 Alpha, thin film, ±0.3°C @ 0°C
 Accuracy:.....±0.1% of span
 Operating Temperature:.....-40° to 85°C (-40° to 185°F)
 Operating Humidity:.....0 to 95% RH non-condensing
 Power Supply:.....18 to 35 Vdc, 15 to 26 Vac
 Consumption:.....22 mA maximum
 Input Voltage Effect:.....Negligible over specified operating range
 Protection Circuitry:.....Reverse voltage protected and output limited
 Output Signal:.....4-20 mA current loop, 0-1, 0-5 or 0-10 Vdc
 Output Drive at 24 Vdc:.....550 ohms max for current output
 10K ohms min for voltage output
 Internal Adjustments:.....Clearly marked ZERO and SPAN pots
 Wiring Connections:.....Screw terminal block (14 to 22 AWG)
 Enclosure:.....Standard - ABS - UL94-5VB - IP61 (NEMA 2)
 *In order to maintain the published Greystone Energy Systems, Inc. reserves the right to make design modifications without prior notice.
 NEMA/IP ratings, properly rated conduit or cable gland adapters must be used.
 Probe:.....304 series stainless steel w/ 60 micron HDPE filter

PART NUMBER SELECTED

PRODUCT SELECTION INFORMATION:

MODEL	Product Description
RH210A	Duct Humidity/Temperature Transmitter

CODE	RH Accuracy
02	2%
03	3%
05	5%

CODE	Temperature Sensor
C	1000 Ω Platinum, Class B, ±0.3°C @ 0°C
L	100 Ω Platinum, Class B, ±0.3°C @ 0°C

CODE	Output Signals (RH and Temperature)
2A	4-20 mA
2D	0-5 Vdc
2E	0-10 Vdc

CODE	Scaled Temperature Range
1	0° - 35°C (32° - 95°F)
2	0° - 50°C (32° - 122°F)
*	Custom ranges available

Custom Scaled Temperature Range:

TYPICAL INSTALLATION:

For complete installation and wiring details, please refer to the product installation instructions.

The duct type probes are installed through a hole in the side of the duct to monitor a single point humidity within the duct. Install the probe in a straight section of duct at a suitable distance downstream from any heating, cooling or humidification devices.

Mounting tabs on the outside of the enclosure for ease of installation .

A terminal block connection is provided. for connection to the Building Automation System.

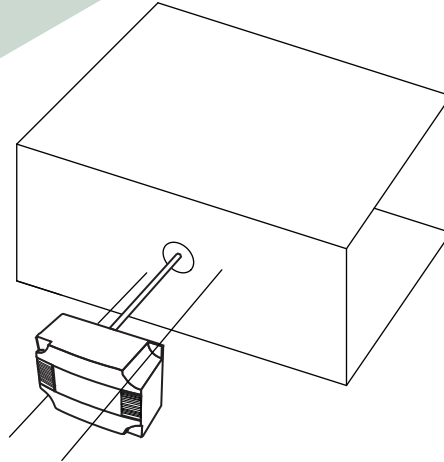

DIMENSIONS:

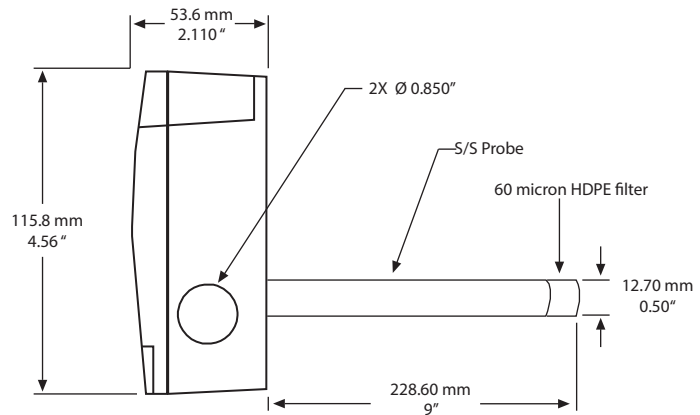
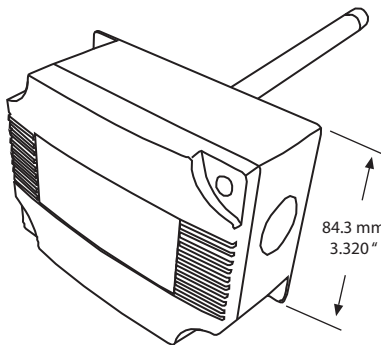

Greystone Energy Systems, Inc. reserves the right to make design modifications without prior notice.



GREYSTONE
ENERGY SYSTEMS INC

Greystone Energy Systems, Inc.
150 English Drive, Moncton,
New Brunswick, Canada E1E 4G7
(506) 853-3057 Fax: (506) 853-6014
North America: 1-800-561-5611
e-mail: mail@greystoneenergy.com
www.greystoneenergy.com

RoHS
COMPLIANT



Greystone Energy Systems Inc. is one of North America's largest ISO registered manufacturers of HVAC/R sensors and transmitters for Building Automation Management Systems.

We have conscientiously established a worldwide reputation as an industry leader by maintaining leading-edge design technology, prompt technical support, and a commitment to on-time deliveries. We take pride in our Quality Management System which is ISO 9001 certified, assuring our customers of consistent product reliability.

GREYSTONE HAS AN **ISO 9001** REGISTERED QUALITY SYSTEM