



Ex-DGM525

Ex - DGM

II 2G Ex d e IIC T6 Gb

II 1/2D Ex ta/tb IIIC T80 °C Da/Db

DVGW tested to DIN EN1854

Gas pressure monitors are suitable for all gases in accordance with DVGW work sheet G260 and for air.



SIL 2 according IEC 61508-2

Technical data

Pressure connection

External thread G 1/2 to DIN 16 288 and internal thread G 1/4 to ISO 228 Part 1 (permissible up to 4 bar).

Switching device

Seawater resistant die cast aluminium GD Al Si 12.

Protection class

IP 65

Pressure sensor materials

See Product Summary

Ambient temperature

-20 to +60°C. At ambient temperatures below 0°C, ensure that condensation cannot occur in the sensor or in the switching device.

Maximum working pressure

See Product Summary

Mounting

Either directly on the pipe or with two 4 mm ø screws on the wall surface.

Mounting position

Vertically upright

Setting

Continuously adjustable via the setting spindle with a screw driver. The set switching pressure is visible in the scale window.

Switching differentials

Largely independent of the set switching pressure. Not adjustable. For values see Product Summary.

Switching capacity	250 VAC		250 VDC		24 VDC	
	(ohm)	(ind)	(ohm)	(ohm)	(ohm)	(ohm)
Ex-d	3 A	2 A	0.03 A		3 A	

Pressure measuring connection

Care must be taken to ensure that a pressure measuring connection is available in a suitable place on the gas appliance.

Component tested for

Fuel gases according to DVGW work sheet G 260

Testing basis

DIN EN1854

Function

Pressure monitor

Direction of action

For maximum and minimum pressure monitoring

Product Summary

Type	Setting range	Switching differential (mean values)	Max. working pressure	Materials in contact with medium	Dimensioned drawing
page 25 + 26					
Ex-DGM506	15...60 mbar	10 mbar	5 bar	1.4104	
Ex-DGM516	40...160 mbar	12 mbar	5 bar	1.4104	4 + 12
Ex-DGM525	100...250 mbar	20 mbar	5 bar	1.4104	

Calibration

The **Ex-DGM** series is calibrated for rising pressure. This means that the adjustable switching pressure on the scale corresponds to the switching point at rising pressure. The reset point is lower by the amount of the switching differential. (See also page 27, 2. Calibration at upper switching point).

For other pressure ranges see type series DWR, page 69

General information about explosion protection

Basic principle

The basic principle of explosion protection is that:

- a) combustible materials (gas, steam, mist or dust) in dangerous quantities
- b) air (or oxygen)
- c) ignition sources

must not occur in the same place.

The permanent or temporary occurrence of explosive mixtures as per a) and b) is often unavoidable, therefore when operating electrical installations care must be taken to ensure that no ignition sources can occur.

In order to accomplish this, standards have been legislated in Europe serving as a basis for various different types of ignition protection. These standards have been recognized in all European countries. Equipment for the reliable prevention of the ignition of ambient explosive gas mixtures must be constructed according to these standards.

In addition to ISO9000ff applies to the production monitoring, the ISO/IEC 80079-34 for ex-protected areas.

These standards are based on European Directive 94/9/EC (ATEX). The goal of this regulation is the harmonization of statutory regulations EN60079 in the area of explosion protection as well as the elimination of trade barriers between Member States. This Directive provides for the harmonization of all standards relevant to the construction of equipment with ignition protection.

The most important types of ignition protection for FEMA products are as follows:

"Ex-d" pressure proof encapsulation	EN 60079-1
"Ex-e" enhanced safety	EN 60079-7
"Ex-t" protection via housing	EN 60079-31
"Ex-i" intrinsically safety	EN 60079-11

Pressure switches

Specially designed FEMA Ex-protected pressure switches are available for use in ex-protection areas. They conform to these standards and are type-tested (Ex-d, Ex-e, Ex-t) and / or have been technically prepared for these areas (Ex-i).

"Ex-d" Pressure-Proof Encapsulation

Switch components and other electrical functional units capable of igniting explosive gas mixtures are encapsulated in a housing which will survive the explosive pressure of an internal explosion and the special design of which prevents the transference of this explosion to the ambient atmosphere.

"Ex-e" Enhanced Safety

This type of ignition protection pertains to the special design of the terminal connection housing. The connection area is grouted and thus specially separated from the microswitch. A type tested terminal block, a type tested cable gland, and the IP65 protection degree all ensure an enhanced safety of "Ex-e" in the connection housing.

"Ex-t" Protection via Housing

This type of ignition protection pertains to dust explosion protection and is based upon the reliable protection of ignition sources against atmospheric dust. For FEMA pressure switches and thermostats for use in dust explosion protected areas, a protection degree of IP65 is required. Together with devices according to "Ex-d" and "Ex-e," devices with "Ex-t" protection are approved for use in gaseous and dust laden atmospheres.

"Ex-i" Intrinsically Safety

The equipment employed in explosion relevant areas are components of inherently safe electrical circuits. An electrical circuit is inherently safe if the amount of energy it contains is so small that no spark or other thermal effect can arise. This reliably prevents the ignition of explosive gas mixtures in the proximity of this equipment. In the context of this directive, pressure switches and thermostats containing no switching components with energy storage effects are referred to as "simple electrical equipment."

General information about explosion protection

Zone classification

Explosion risk areas are grouped into zones according to the likelihood of a dangerous explosive atmosphere **according to EN 1127-1** occurring.

When assessing the explosion hazard, i.e. when identifying explosion risk areas, the "Guidelines for the Avoidance of Danger due to Explosive Atmospheres with Examples (ExRL)" of the German Insurance Association for the Chemical Industry must be taken into account.

If the situation concerns a special case or if doubts exist as to the definition of explosion risk areas, the matter shall be decided by the supervisory authorities (Trade Supervisory Office, where applicable with the assistance of the Insurance Association or the Technical Control Boards.

In Zones 0 (20) and 1 (21), only electrical equipment for which a type test certificate has been issued by a recognized testing agency may be used. In Zone 0 (20), however, only equipment expressly authorized for that zone may be used. Equipment approved for use in Zones 0 (20) and 1 (21) may also be used in Zone 2 (22). Under the new European Directive 94/9 EC (ATEX 100a), a distinction is made between **gas atmospheres** and **dust atmospheres**. This results in the following zone classifications:

Gas	Zone 0	continuously or for long periods	Zone 0 (gas) is a place in which a dangerous explosive atmosphere is present continuously or for long periods. This normally includes only the interior of containers or the interior of apparatus (evaporators, reaction vessels etc.), if the conditions of Zone 0 are fulfilled. Continuous danger > 1000 hours / year.
	Zone 1	occasionally	Zone 1 (gas) is a place in which a dangerous explosive atmosphere can be expected to occur occasionally in normal operation. This may include the immediate vicinity of Zone 0. Occasional danger = 10 to 1000 hours / year.
	Zone 2	seldom and for short periods	Zone 2 (gas) is a place in which a dangerous explosive atmosphere can be expected to occur only rarely and then only for short periods. This may include areas surrounding Zones 0 and/or 1. Danger only under abnormal operating conditions < 10 hours / year.
Dust	Zone 20	continuously or for long periods	Zone 20 (dust) is a place in which a dangerous explosive atmosphere in the form of a cloud of dust in air is present continuously or for long periods, and in which dust deposits of unknown or excessive thickness may be formed. Dust deposits on their own do not form a Zone 20. Continuous danger > 1000 hours / year.
	Zone 21	occasionally	Zone 21 (dust) is a place in which a dangerous explosive atmosphere in the form of a cloud of dust in air may occasionally occur in normal operation, and in which deposits or layers of inflammable dust may generally be present. This may also include the immediate vicinity of Zone 20. Occasional danger = 10 to 1000 hours / year.
	Zone 22	seldom and for short periods	Zone 22 (dust) is a place in which a dangerous explosive atmosphere may be expected to occur only rarely and then only for short periods. This may include areas in the vicinity of Zones 20 and 21. Danger only under abnormal operating conditions < 10 hours / year.

General information about explosion protection

Explosion group

The requirements for explosion protected equipment depend on the gases and / or steam present on the equipment and on the dusts lying on, adhering to and / or surrounding the equipment. This affects the gap dimensions required for pressure proof encapsulation and, in the case of intrinsically safe circuits, the maximum permitted current and voltage values. Gases, steam and dusts are therefore subdivided into various explosion groups.

The danger of the gases rises from explosion group IIA to IIC. The requirements for electrical equipment in these explosion groups increase accordingly. Electrical equipment approved for IIC may also be used for all other explosion groups.

Temperature class

The maximum surface temperature of an item of equipment must always be lower than the ignition temperature of the gas, steam or dust mixture. The temperature class is therefore a measure of the maximum surface temperature of an item of equipment.

Temperature class °C	Ignition temperature °C	Maximum surface temperature °C
T1	> 450	450
T2	> 300	300
T3	> 200	200
T4	> 135	135
T5	> 100	100
T6	> 85	85

Equipment Protection Level (EPL)

In addition to the afore mentioned types of ignition protection, the new norms IEC and EN60079ff have introduced the corresponding Equipment Protection Levels (EPL).

Zone (Gas-Ex)	EPL	Zone (Staub-Ex)	EPL	Protection Level
0	Ga	20	Da	highest
1	Gb	21	Db	high
2	Gc	22	Dc	standard

Example: Ex d e IIC T6 Gb:

Device is designed for Zone 1 for gas group IIC and gas equipment protection level "high level of protection".

Marking of Explosion-Protected Electrical Equipment

In addition to the usual data (manufacturer, model, serial number, electrical data), the explosion protection information is likewise to be included in the marking.

According to Directive 94/9/EC (ATEX), in compliance with the IEC recommendation and the currently valid standards, the following forms of identification are to be followed.

Example for FEMA Pressure Switch

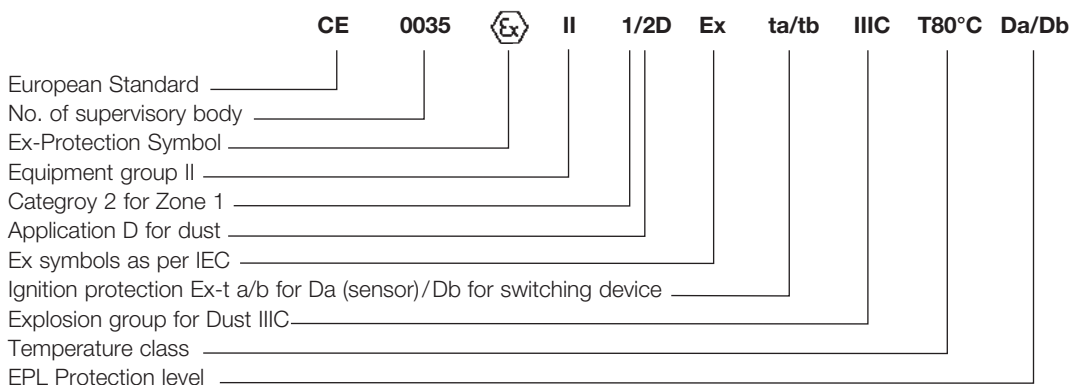



Ex devices

Pressure monitoring in explosion risk areas, Zones 1, 2 and 20, 21, 22

Specially equipped pressure switches can also be used in explosion risk areas Zone 1, 2 and 20, 21, 22. The following alternatives are possible:

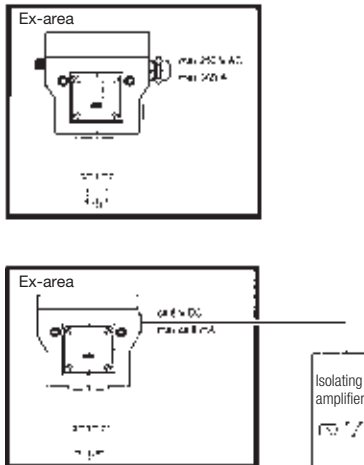

1. Type of ignition protection Ex-d, Ex-e and Ex-t:

The pressure switch with protection type "Flameproof Ex-d and Increased Safety Ex-e" can be used with the switch device in hazardous areas of zone 1 and 2 for flammable gas mixtures. For use in dust atmospheres, the protection is "protected by enclosure Ex-t".

The switching device may be used in hazardous areas of zones 21 and 22 for explosive dusts. In addition, for the dust explosion protection zone 20 on the sensor (device screwed into container walls, which may occur in the interior permanent dust atmosphere).

The permissible values for switching voltage, switching capacity and ambient temperature please refer to the detailed description of the Ex-equipment, and the installation and operating instructions. In addition, please note the general rules for the use and installation of equipment in hazardous atmosphere.

Special circuits, as well as versions with adjustable switching differential or internal interlock (reclosing lock) are not possible.

2. Ignition protection Ex-i

All pressure switches with features for intrinsically safe circuits can be used with the switching device in hazardous areas Zone 1 and 2 (Gas) and zones 21 and 22 (Dust). In addition, the sensor in hazardous areas Zone 0 (Gas) and 20 (Dust) may be screwed. (Inside tank = defined as zone 0 or zone 20). A circuit is considered to be "intrinsically safe" if the amount of energy conveyed therein is not capable of generating an ignitable sparks. This pressure switch can only be operated in combination with a suitable isolating switching amplifier, which is approved for the type Ex-i. Suitable variants must be selected for this pressure switch with resistor combination for line and short circuit monitoring. Because of the low voltages and currents in intrinsically safe circuits, micro switches with gold contacts are used for pressure monitors with automatic reset. For limiter (with internal interlock) micro switches with silver contacts are used. FEMA pressure switches for use in intrinsically safe circuits are marked by blue terminals and cable entries. In addition, the pressure switch has been tested by a "notified body". The units get a serial number and the nameplate inform about the ignition protection and registration number.

Ignition protection for pressure monitoring in Zones 0 (20), 1 (21) and 2 (22)

Pressure proof encapsulation Ex-d (EN 60079-0:2009)
Enhanced safety Ex-e (EN 60079-7:2007)
Protection via housing Ex-t (EN60079-31:2009)
Ex-...

Intrinsically safe Ex-i (EN 60079 - 11: 2012)
D...574, ...-576 (gold-plated contact, monitor)
D...575, ...-577 (silver-plated contact, limiter)

Ignition protection type:

CE 0035 II 2G Ex d e IIC T6 Gb

CE 0035 II 1/2D Ex ta/tb IIIC T80°C Da/Db

ATEX approval for the complete switching device

Pressure switches with a silver contact

Switching capacity: max. 3 A, 250 VAC
 min. 2mA, 24 VDC

Ignition protection type:

CE 0035 II 1/2G Ex ia T6 Ga/Gb

CE 0035 II 1/2D Ex ia IIIC T85°C

ATEX approval for the complete switching device and for isolating amplifier

Pressure switches with gold plated contacts (monitors)

Pressure switches with silver plated contacts (limiter)

Rate value without resistor combination
 ...-513 / ...-563:

Ui: 24VDC li: 100mA

Ci: 1nF Li: 100µH

Rate value with resistor combination
 ...-574 / ...-575 / ...-576 / ...-577:

Ui: 14VDC Ri: 1500 Ohm

Ci: 1nF Li: 100µH

The pressure switch can be installed within the Ex-Zone.

Pressure switch will be installed in Ex-Zone
 The isolating amplifier must be installed outside the Ex-Zone.

Mechanical pressure switches

Technical features / Advantages

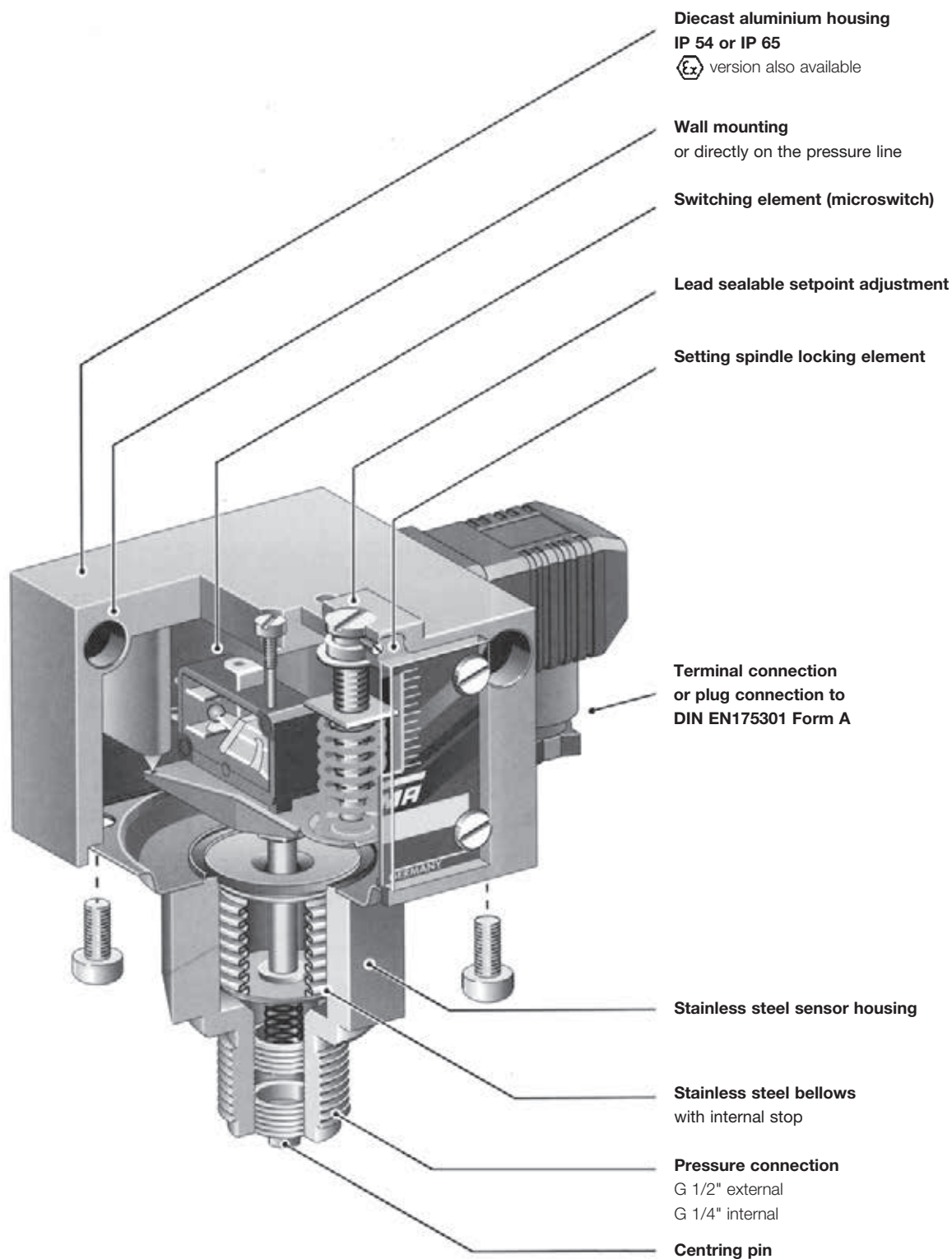

Definitions

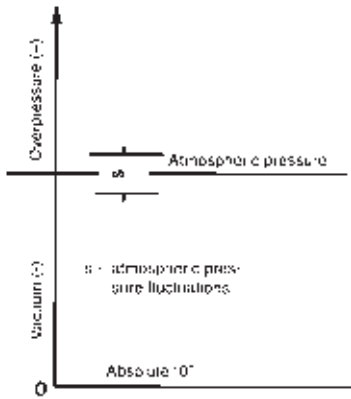

Pressure data

- Overpressure** Pressure **over** the relevant atmospheric pressure. The reference point is atmospheric pressure.
- Vacuum** Pressure **under** the relevant atmospheric pressure. The reference point is atmospheric pressure.
- Absolute pressure** Overpressure relative to absolute vacuum.
- Differential pressure** Difference in pressure between 2 pressure measuring points.
- Relative pressure** Overpressure or vacuum relative to atmospheric pressure.

Pressure data in all FEMA documents refers to relative pressure.

That is to say, it concerns pressure differentials relative to atmospheric pressure. Overpressures have a positive sign, vacuums a negative sign.

Permissible working pressure (maximum permissible pressure)

The maximum working pressure is defined as the upper limit at which the operation, switching reliability and water tightness are in no way impaired (for values see Product summary).

Bursting pressure (test pressure)

Type-tested products undergo a pressure test certified by TÜV affirming that the bursting pressure reaches at least the values mentioned in the Product summary. During the pressure tests the measuring bellows are permanently deformed, but the pressurized parts do not leak or burst. The bursting pressure is usually a multiple of the permissible working pressure.

Setting range

Pressure range in which the cutoff pressure can be set with the setting spindle.

Pressure units

Unit	bar	mbar	Pa	kPa	MPa	(psi) lb/m ²
1 bar	1	1000	10 ⁵	100	0.1	14.5
1 mbar	0.001	1	100	0.1	10 ⁻⁴	0.0145
1 Pa	10 ⁻⁵	0.01	1	0.001	10 ⁻⁶	1.45 · 10 ⁻⁴
1 kPa	0,01	10	1000	1	0.001	0,145
1 MPa	10	10 ⁴	10 ⁶	1000	1	145

In FEMA documents pressures are stated in **bar** or **mbar**.

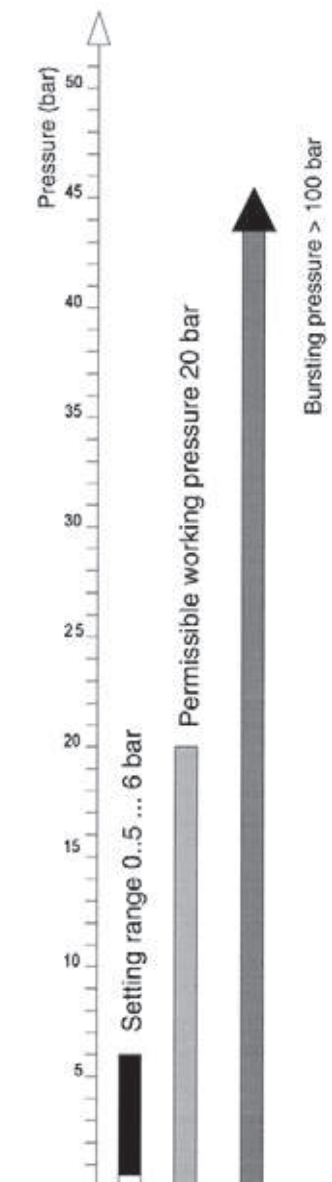

Pressure data for a pressure switch based on the example of DWR625:

Setting range: 0.5-6 bar
Perm. working pressure: 20 bar
Bursting pressure: >100 bar

Important:

All pressure data refers to overpressures or vacuums relative to atmospheric pressure. Overpressures have a positive sign, vacuums a negative sign.

Definitions

Maximum pressure monitoring

$RSP = SP - xd$

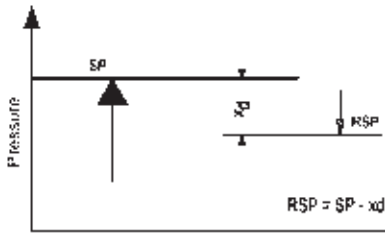

SP = switching point RSP = reset point
xd = switching differential (hysteresis)

Minimum pressure monitoring

$RSP = SP + xd$

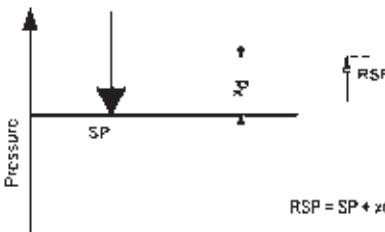

SP = switching point RSP = reset point
xd = switching differential (hysteresis)

Switching differential

The switching differential (hysteresis) is the difference in pressure between the **switching point (SP)** and the **reset point (RSP)** of a pressure switch. Switching differential tolerances occur due to tolerances in the microswitches, springs and pressure bellows. Therefore the data in the product summaries always refers to average values. In the case of limiter functions the switching differential has no significance, as one is only interested in the switching point at which cutoff occurs, not the reset point. For a **controller function**, i. e. in the case of pressure switches used to switch a burner, pump etc. **on and off**, a pressure switch with an **adjustable switching differential** should be chosen. The switching frequency of the burner or pump can be varied by changing the switching differential.

Adjustable switching differential/ calibration

In the case of pressure switches with adjustable switching differential, the hysteresis can be set within the specified limits. The switching point (SP) and reset point (RSP) are precisely definable. When setting the pressure switch, the switching differential situation and the type of factory calibration must be taken into account. Some pressure switches (e.g. minimum pressure monitors of the DCM series) are calibrated under "falling" pressure, i.e. switching under falling pressure takes place at the scale value with the switching differential being above it. The device switches back at scale value + switching differential. If the pressure switch is calibrated under rising pressure, switching takes place at the scale value and the device switches back at scale value - switching differential (see direction of action). The calibration method is indicated in the data sheets.

Direction of action

In principle, any pressure switch can be used for both maximum pressure and minimum pressure monitoring. This excludes pressure limiters, whose direction of action (maximum or minimum) is predefined. The only thing to remember is that the scale reading may deviate by the amount of the switching differential. See example at bottom left: The scale value is 2.8 bar.

Maximum pressure monitoring

With rising pressure, switching takes place once the preset switching pressure is reached (SP). The reset point (RSP) is lower by the amount of the switching differential.

Minimum pressure monitoring

With falling pressure, switching takes place once the preset switching pressure is reached (SP). The reset point (RSP) is higher by the amount of the switching differential.

Direction of action in vacuum range

It is particularly important to define the direction of action in the vacuum range. Rising does not mean a rising vacuum, but rising pressure (as viewed from absolute "0"). "Falling" pressure means a rising vacuum. For example: Vacuum switch set to -0.6 bar falling means: Switching (SP) takes place under falling pressure (rising vacuum) at -0.6 bar. The reset point is higher by the amount of the switching differential (e.g. at -0.55 bar).

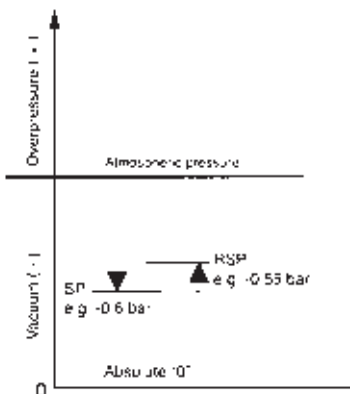

Setting a pressure switch

To define the switching point of a pressure switch exactly, it is necessary to determine the direction of action in addition to the pressure. "Rising" means that switching takes place at the set value when the pressure rises. The reset point is then lower by the amount of the switching differential. "Falling" means exactly the opposite.

Please note when specifying the setting of a pressure switch:

In addition to the switching point it is also necessary to specify the direction of action (falling or rising).

Example for selection of a pressure switch:

A pump is to be turned on at 2.8 bar and off again at 4.2 bar.
Chosen type: DCMV6 according to data sheet DCM. Setting: Scale pointer to 2.8 bar (lower switching point). Switching differential to 1.4 bar (set according to pressure gauge).
Cutoff point: 2.8 bar + 1.4 bar = 4.2 bar.

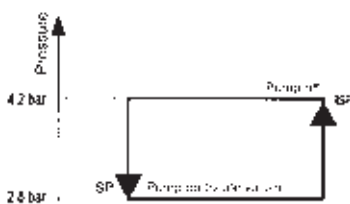

SP = switching point RSP = reset point

Operating mode

The pressure prevailing in the sensor housing (1) acts on the measuring bellows (2). Changes in pressure lead to movements of the measuring bellows (2) which are transmitted via a thrust pin (4) to the connecting bridge (5). The connecting bridge is frictionlessly mounted on hardened points (6). When the pressure rises the connecting bridge (5) moves upwards and operates the microswitch (7). A counter-force is provided by the spring (8), whose pre-tension can be modified by the adjusting screw (9) (switching point adjustment). Turning the setting spindle (9) moves the running nut (10) and modifies the pre-tension of the spring (8). The screw (11) is used to calibrate the microswitch in the factory. The counter pressure spring (12) ensures stable switching behaviour, even at low setting values.

- 1 = Pressure connection
- 2 = Measuring bellows
- 3 = Sensor housing
- 4 = Thrust pin
- 5 = Connecting bridge
- 6 = Pivot points
- 7 = Microswitch or other switching elements
- 8 = Setting spring
- 9 = Setting spindle (switching point adjustment)
- 10 = Running nut (switching point indicator)
- 11 = Microswitch calibration screw (factory calibration)
- 12 = Counter pressure spring

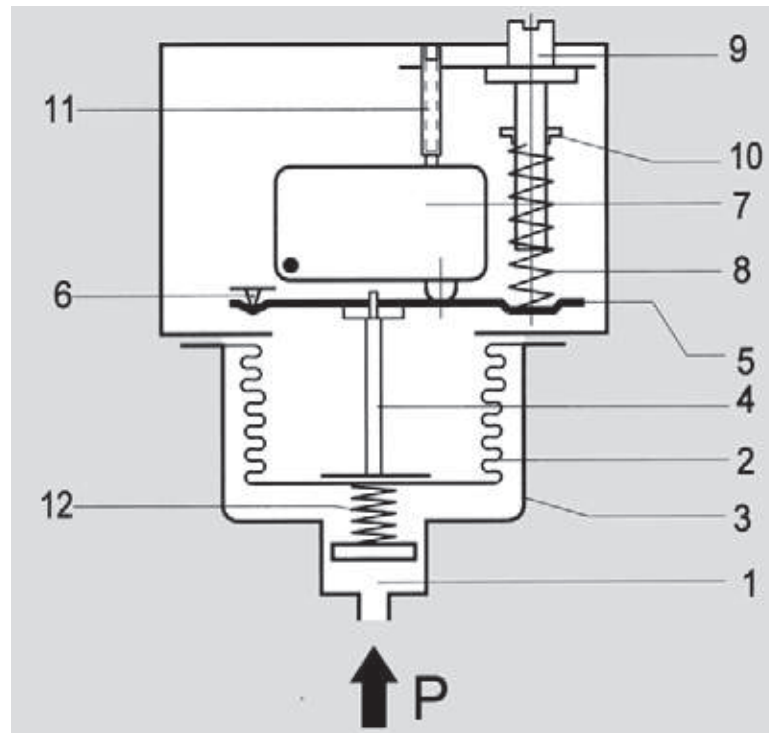

Pressure sensors

Apart from a few exceptions in the low-pressure range, all pressure sensors have measuring bellows, some made of copper alloy, but the majority of high-quality stainless steel. Measured on the basis of permitted values, the measuring bellows are exposed to a minimal load and perform only a small lifting movement. This results in a long service life with little switching point drift and high operating reliability. Furthermore, the stroke of the bellows is limited by an internal stop so that the forces resulting from the overpressure cannot be transmitted to the switching device. The parts of the sensor in contact with the medium are welded together without filler metals. The sensors contain no seals. Copper bellows, which are used only for low pressure ranges, are soldered to the sensor housing. The sensor housing and all parts of the sensor in contact with the medium can also be made entirely from stainless steel 1.4571 (DNS series). Precise material data can be found in the individual data sheets.

Pressure connection

The pressure connection on all pressure switches is executed in accordance with DIN 16288 (pressure gauge connection G 1/2A). If desired, the connection can also be made with a G 1/4 internal thread in accordance with ISO 228 Part 1.

Maximum screw-in depth on the G 1/4 internal thread = 9 mm.

Centring pin

In the case of connection to the G 1/2 external thread with seal in the thread (i.e. without the usual stationary seal on the pressure gauge connection), the accompanying centring pin is not needed. Differential pressure switches have 2 pressure connections (max. and min.), each of which are to be connected to a G 1/4 internal thread.

Principal technical data

Valid for all pressure of the DCM, VCM, VNM, DNM, DWR, DGM, DNS, DWAM, DWAMV and DDCM series that have a microswitch. The technical data of type-tested units may differ slightly (please refer to particular type sheet).

Ex-i-version



Ex version (Ex-d)



Switch housing	Die cast aluminium GDAISi 12	Die cast aluminium GDAISi 12
Pressure connection	G 1/2" external thread (pressure gauge connection) and G 1/4" internal thread. 1/4" internal thread for DDCM differential pressure switches	G 1/2" external thread (pressure gauge connection) and G 1/4" internal thread. 1/4" internal thread for DDCM differential pressure switches
Switching function and connection scheme (applies only to version with microswitch)	Floating changeover contact. With rising pressure single pole switching from 3-1 to 3-2	Floating changeover contact. With rising pressure single pole switching from 3-1 to 3-2
Switching capacity	max.: 100mA, 24VDC min.: 2mA, 5VDC	3 A at 250 VAC 2 A at 250 VAC inductive 3 A at 24 VDC 0.1 A at 250 VDC min. 2 mA, 24 VDC
Mounting position	Vertical	Vertical
Protection class (in vertical position)	IP 65	IP 65
Explosion protection Code	Ex II 1/2G Ex ia IIC T6 Ga/Gb Ex II 1/2D Ex ia IIIC T80 °C	Ex II 2G Ex d e IIC T6 Gb Ex II 1/2D Ex ta/tb IIIC T80 °C Da/Db
EC Type Examination Certificate Number	IBExU12ATEX1040	IBExU12ATEX1040
Electrical connection	Terminal connection	Terminal connection
Cable entry	M 16 x 1.5	M 16 x 1.5
Ambient temperature	-25 to +60 °C (exceptions: DWAM series -20 to +60 °C DGM and FD series: -25 to +60 °C DCM4016, 4025, 1000, VCM4156: -15 to +60 °C)	-20 to +60 °C
Medium temperature	Max. 60 °C	Max. 60 °C
Relative humidity	15 to 95 % (non-condensing)	15 to 95 % (non-condensing)
Switching point	After removing switch housing cover	After removing switch housing cover
Hysteresis	Not adjustable	Not adjustable
Vacuum	Higher medium temperatures are possible provided the above limits for the switching device are ensured by suitable measures (e.g. siphon). All pressure switches can operate under vacuum. This will not damage the device.	
Repetition accuracy of switching points	< 1 % of the working range (for pressure ranges > 1 bar).	
Vibration resistance	No significant deviations up to 4 g.	
Mechanical durability (pressure sensor)	With sinusoidal pressure application and room temperature, 10 x 10 ⁶ switching cycles. The expected life depends to a very large extent on the type of pressure application, therefore this figure can serve only as a rough estimate. With pulsating pressure or pressure impacts in hydraulic systems, pressure surge reduction is recommended.	
Electronical durability (microswitch)	100.000 switching cycles at nominal current 8 A, 250 VAC. A reduced contact load increases the number of possible switching cycles.	
Isolation values	Overvoltage category III, contamination class 3, reference surge voltage 4000 V. Conformity to DIN VDE 0110 is confirmed.	
Oil and grease-free	The parts of all pressure switches in contact with the medium are oil and grease free (except the HCD...and DPS...series). The sensors are hermetically sealed and contain no seals (also see ZF1979, special packing).	

Dimensioned drawings of switch housings (mm)

1 Housing 200 (plug connection)

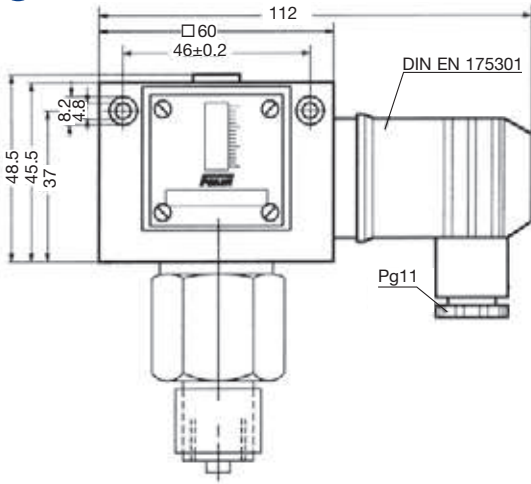

2 Housing 300 (terminal connection)

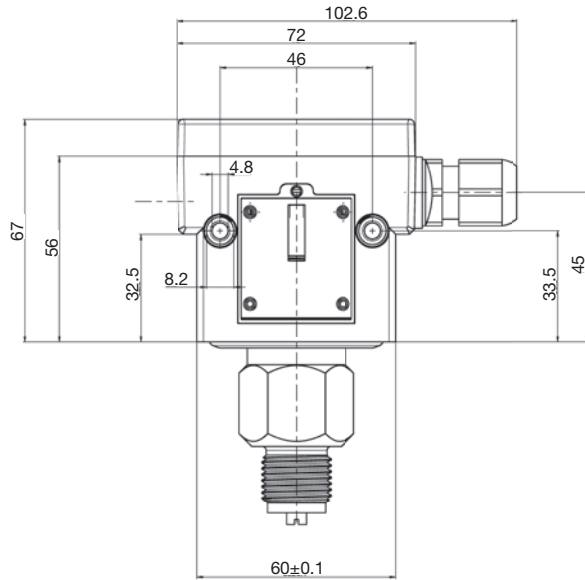

3 Housing 500 (terminal connection Ex-i)

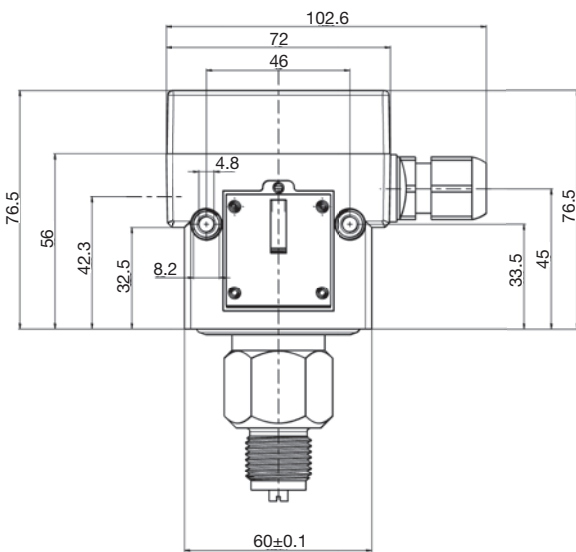

4 Housing 700 (terminal connection Ex-d)

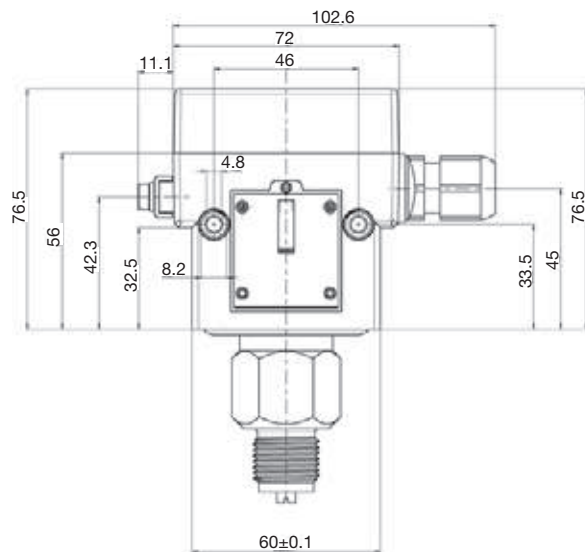

Dimensioned drawings of pressure sensors (mm)

10

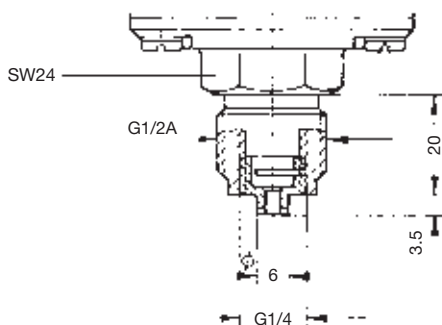

11

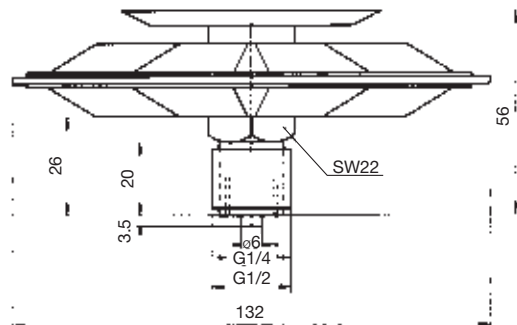

Dimensioned drawings of pressure sensors (mm)

12

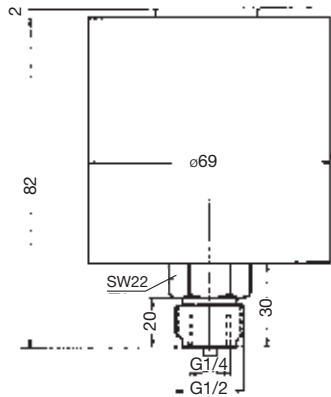

13

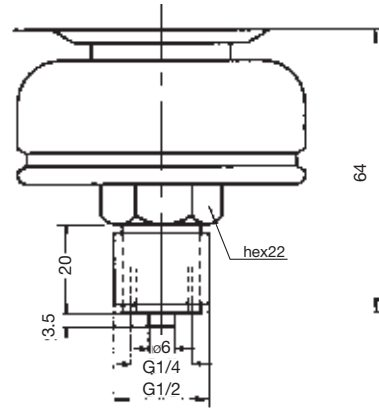

14

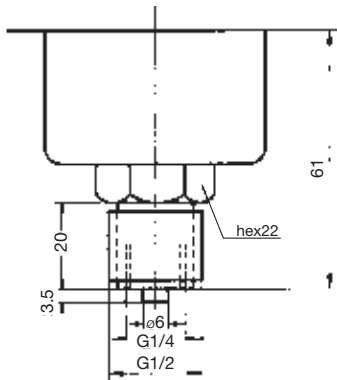

15

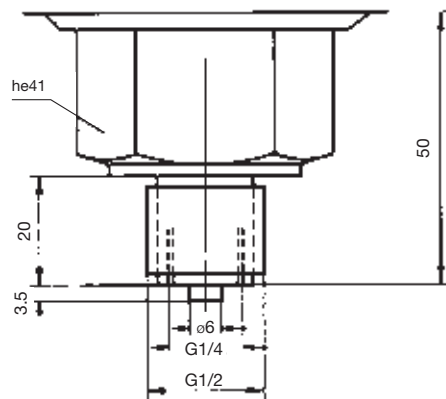

16-19

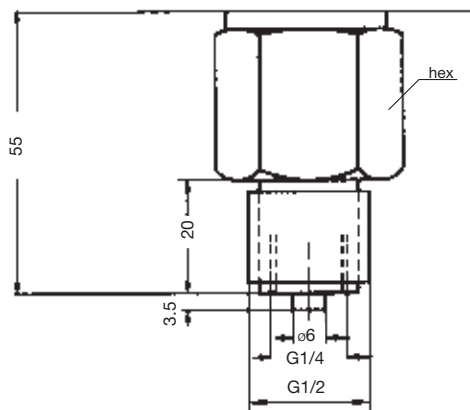

Dimensioned drawing	hex (mm)
16	22
17	24
18	30
19	32

20

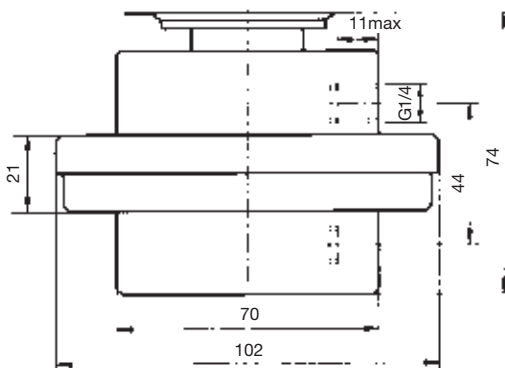

21

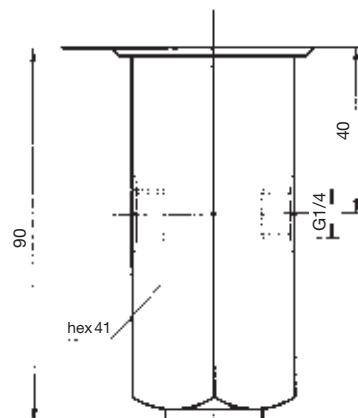

Service functions

Devices with service functions will be produced according to the customer's specifications.

The system requires that these product combinations are identified in such a way as to prevent any possibility of confusion. These combinations are characterised by a product code with the suffix "-S" on the packaging label as well as separate labels with barcodes for each service function.

Service functions	Plug connection 200 series	Terminal connection 300 series	Ex-i / Ex-d
Adjustment according to customer's instruction:			
- one switching point	ZF1970*	ZF1970*	ZF1970*
- two switching points or defined switching differential	ZF1972*	ZF1972*	-
Adjustment and lead sealing according to customer's instruction:			
- one switching point	ZF1971*	- -	
- two switching points or defined switching differential	ZF1973*	- -	
Labelling of units according to customer's instruction with sticker	ZF1978	ZF1978	ZF1978
Special packing for oil and grease-free storage	ZF1979	ZF1979	ZF1979
Test reports according to EN 10 204			
- Certificate 2.2 based on non specific specimen test	WZ2.2	WZ2.2	WZ2.2
- Inspection test certificate 3.1 based on specific test	AZ3.1B1	AZ3.1B1	AZ3.1B1
- Inspection test certificate for FV separating diaphragms	AZ3.1-V	AZ3.1-V	AZ3.1-V

* **Switching point adjustment:** Please specify **switching point and direction of action** (rising or falling pressure).

Service functions are available for the following type series (including Ex-versions):

Pressure switches: DCM, DNM, DNS, VNS, VCM, VNM, DDCM, DWR, DWAM, DWAMV, SDBAM, DGM, FD

Ordering devices with service functions

Example:

Ordering 1 DCM6, set at 4 bar rising, identified with code PSH008 as requested by the customer and acceptance test certificate 3.1.

The order confirmation contains:

- 1 DCM6-S ("S" is need for factory = following lines belong to this item)
- 1 ZF1970: set to 4 bar rising
- 1 ZF1978: PSH008
- 1 AZ3.1B1

Included items: Labels with barcodes on the packaging:
DCM6-S
ZF1970: set to 4 bar rising
ZF1978: PSH008
AZ3.1B1

Pack contents: 1 DCM6 (without "S" suffix) marked
1 ZF1970: set to 4 bar rising
1 ZF1978: PSH008
1 AZ3.1 B1 will be sent by extra post
1 Installation and operating instructions