



**ECOTRIC**®

Enjoy Riding



FAT26S900-MB-XXX

FAT26S900-BL-XXX

FAT26S900-O-XXX

(XXX represents any alphanumeric character)

# TABLE OF CONTENTS

Carton Contents.....	- 1 -
WARNING.....	- 3 -
Avertissement.....	- 4 -
Assembling Instruction.....	- 5 -
Front Wheel Installation.....	- 5 -
Handle Bar,Display and Front Reflector Installation.....	- 7 -
Seat Post Installation.....	- 8 -
Pedals Installation.....	- 9 -
Battery Installation & Removing & Charging.....	- 10 -
Operating Instructions/INSTRUCTIONS D'UTILISATION.....	- 11 -
Display Instrument Setting.....	- 13 -
Presentation of Screen.....	- 13 -
Display Setting.....	- 13 -
Troubleshooting.....	- 14 -
The display can not light up.....	- 14 -
The throttle does not work.....	- 15 -
Error Codes.....	- 16 -
Warranty Information.....	- 17 -
Situations that are not covered by warranty.....	- 17 -
18 months Limited Warranty Components.....	- 17 -
Exclusions.....	- 17 -
Return Policy.....	- 18 -
FAQ.....	- 19 -
Q: How does after-sale customer service/ warranty work?.....	- 19 -
Q: I'm tech inclined and think I can fix it myself,does that void the warranty if I do?.....	- 19 -
Q:Why is the charger hot?.....	- 19 -
Q:What is the range of this bike?.....	- 19 -
Q: Can I ride the bike in the rain?.....	- 19 -
Q: What is the most important thing for maintaining battery.....	- 19 -
Q: Do you have spare keys for the E-bike?.....	- 19 -
Battery And Charger Care.....	- 20 -
USER MAINTENANCE INSTRUCTIONS.....	- 21 -
Safety.....	- 22 -
General Warning.....	- 23 -
Electrical Parameters.....	- 24 -
The Universal Wiring Diagram.....	- 25 -
Recording Your ECOTRIC Bike Info.....	- 25 -

## Carton Contents

(x1) ECOTRIC Bike	(x1) Tool Kit
(x1) Lithium Ion Battery	(x2) Keys
(x1) Battery Charger	(x1) Owner's user Manual
(x1) Kit Box	(x2) Reflectors
(x2) Pedals	(x1) Saddle



# ELECTRIC BIKES

First of all, we would like to thank you for choosing the ECOTRIC electric bike. We believe this technology, with the benefits of electric propulsion, provides you with the perfect vehicle to increase your personal mobility.

Our brush-less electric hub motor allows you to run errands or commute to work while saving money on gas and reducing your environmental impact on our world. It also gives you the opportunity to pedal if you want to get exercise along the way.

All this and it is just plain fun to ride!

If you have any concerns, questions or suggestions about the ECOTRIC electric bike, please contact us at the website where you bought the bike, we will always do our best to serve you. Again, thanks for choosing ECOTRIC.

## **PLEASE NOTE:**

**THIS MANUAL IS NOT INTENDED AS A DETAILED USER, SERVICE, REPAIR OR MAINTENANCE MANUAL. PLEASE SEEK ASSISTANCE FROM A QUALIFIED TECHNICIAN FOR SERVICE, REPAIRS OR MAINTENANCE.**

# WARNING

Electric Bikes can be dangerous to use. The user or consumer assumes all risk of personal injuries, damage, or failure of the bicycle or system and all other losses or damages to themselves and others and to any property arising as a result of using the bicycle.

As with all mechanical components, the bicycle is subjected to wear and high stresses. Different materials and components may react to wear or stress fatigue in different ways. If the design life of a component has been exceeded, it may suddenly fail possibly causing injuries to the rider. Any form of crack, scratches or change of coloring in highly stressed areas indicate that the life of the component has been reached and it should be replaced.

For replacement parts, technical information and warranty assistance, please feel free contact us.

**YOUR INSURANCE POLICIES MAY NOT PROVIDE  
COVERAGE FOR ACCIDENTS INVOLVING THE USE OF  
THIS BICYCLE. TO DETERMINE IF COVERAGE IS  
PROVIDED YOU SHOULD CONTACT YOUR INSURANCE  
COMPANY OR AGENT.**

**DO NOT DISASSEMBLE, MODIFY  
OR REPLACE ELECTRICAL PARTS.**

# Assembling Instruction

## Front Wheel Installation

CAUTION: Your Electric bike is equipped with a front disk brake. Be careful not to damage the disk, caliper or brake pads when reinserting the disk into the caliper. Never activate a disk brake's control lever unless the disk is correctly inserted in the caliper.

(1) Carefully take your bike out of the carton and gently rest it in place with the kickstand down(Figure.1-1).



Figure. 1-1

(2) Remove all of the inside cardboard protection and bubble wrap on the bike.

(3) Please locate and set aside the kit box containing the battery charger, pedals, and tool kit etc.

(4) Remove the rubber pad and metal block from the front wheel and frontfork(Figure.1-2)



Figure. 1-2

(5) The fork is curved, please make sure the concave of the fork facing forward(Figure.1-3)



Figure. 1-3

(6) With the steering fork facing forward, insert the front wheel between the fork blades so that the axle seats firmly at the top of the fork dropouts. (Figure.1-4)

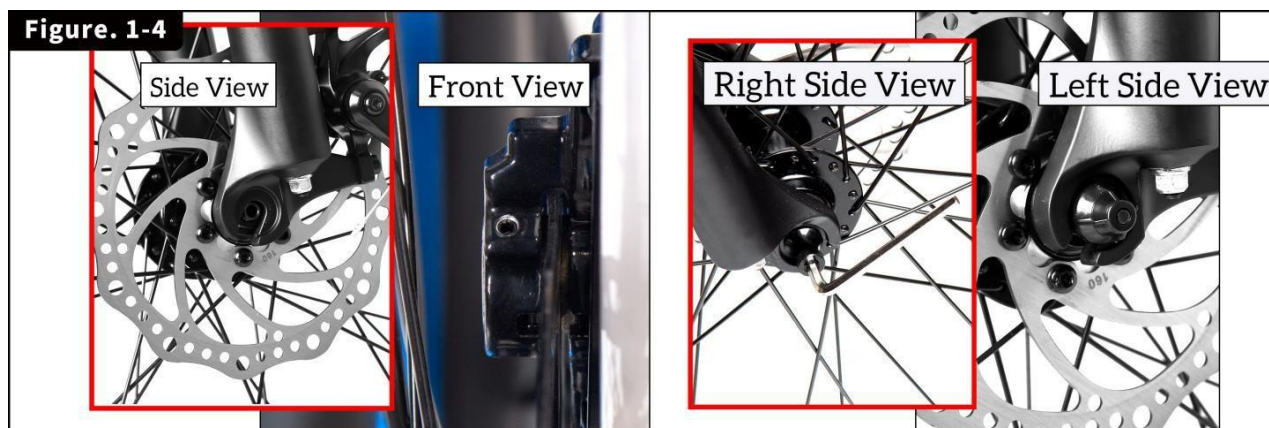

(7) While pushing the wheel firmly to the top of the slots in the fork dropouts, and at the same time centering the wheel rim in the fork.

(8) Use the Allen Wrench to tighten the nut of the quick release (Figure. 1-5). Note: The small spring heads face the center and one on each side of the wheel.

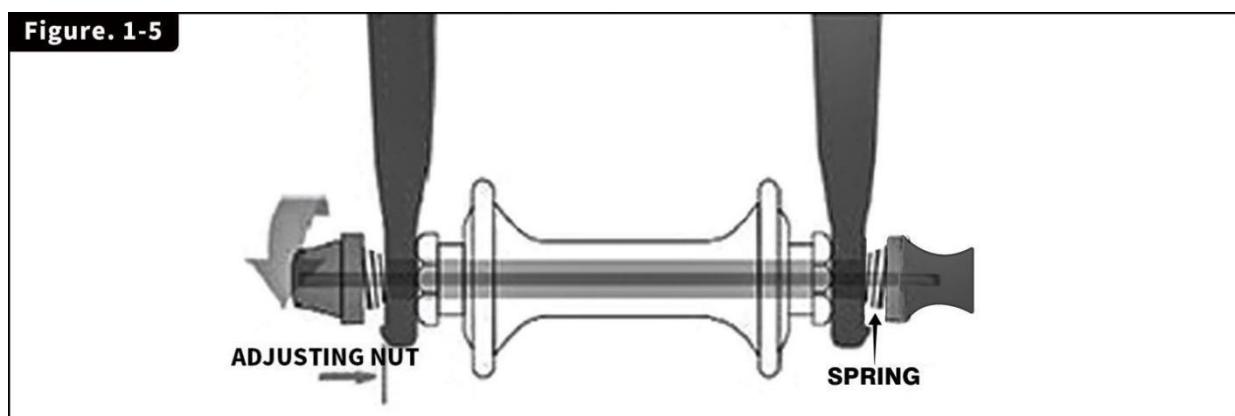



## Handle Bar, Display and Front Reflector Installation

1. Loosen the bolt on top of the stem, then rotate the stem through 90 degrees (Figure 2-1)
2. Unscrew the 4 screws in front of the stem with a 5mm hexagonal spanner, place the handle bar on the stem, tighten the 4 screws slightly and position the handlebars to your desired comfort level, then tighten the four bolts in turn until fully tightened (Figure 2-2)

**Please Note:** Before installing the handle bar, please pay attention to the wires harness that connect to it, please make sure the wire harness are not twined together. (Figure 2-3)

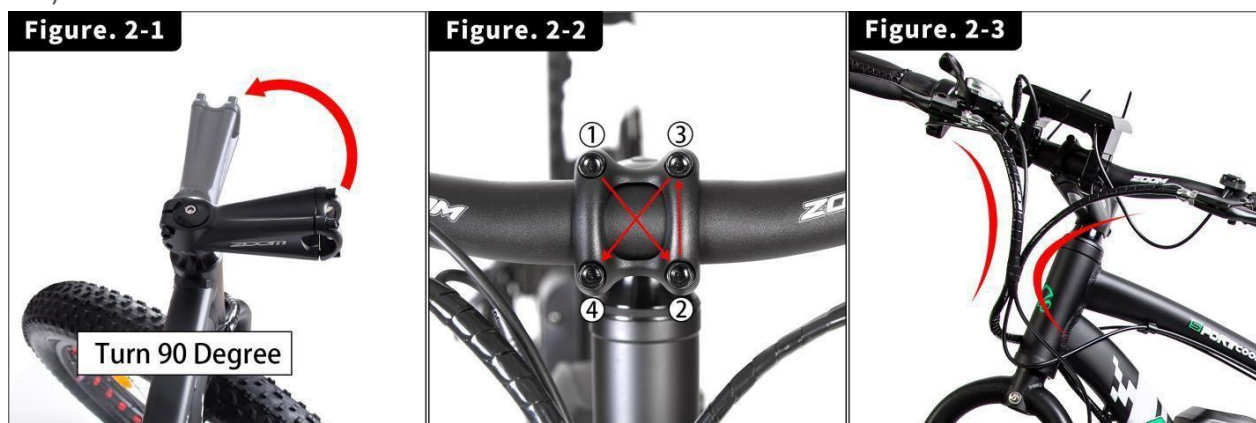

3. Once the handlebars are aligned and the top bolt is slightly secured, tighten the top bolt with a 5mm hexagonal spanner firmly (Figure 2-4). After tightening the top bolt, tighten the two side bolts on the stem with a 6mm hexagonal spanner firmly (Figure 2-5). After all three bolts have been securely fastened, make sure there is no play in the headset.

4. Unscrew the 2 screws on the display, then install the display on the center of the handle bar (Figure 2-6); unscrew the bolt on the front of the fork, then install the front reflector.



Install instruction on YouTube: <https://youtu.be/AdTEu5iVJZA>

### WARNING:

Do not over-tighten the stem bolt. Over-tightening the stem bolt can damage the steering system and cause loss of control.

## Seat Post Installation

1. Please pay attention to the vertical lines on the seat post, it is the minimum insert line or safety line, please make sure the post is installed into the frame deeper than the minimum insertion line. It is at the bottom of the seat post (Figure. 3-1)

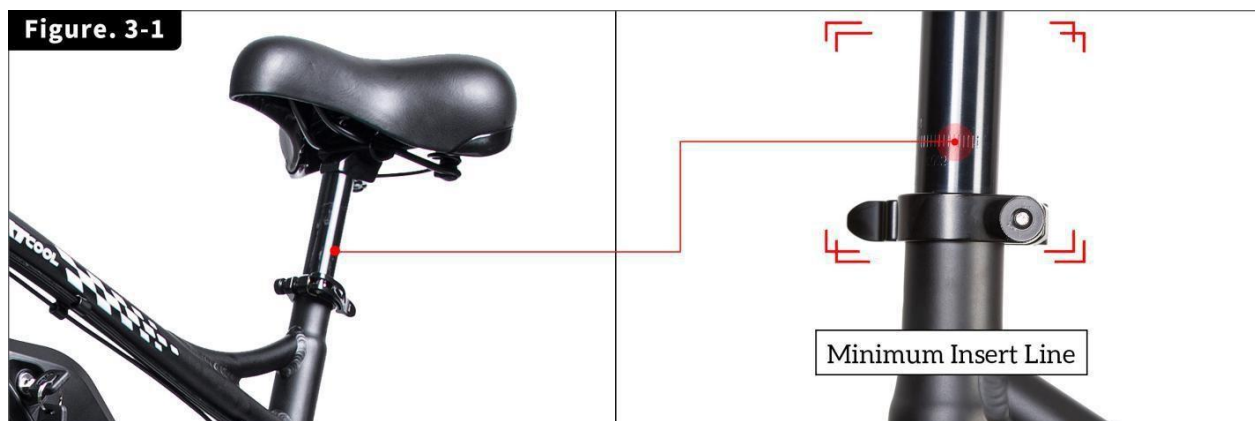

**Warning:** It could break the seat tube during riding if the seat post does not install correctly. **It is not covered by warranty.**

2. Un-clamp the clamp on the seat tube, insert the seat post into the seat tube, adjusting the seat to a comfortable height, tighten the tension adjusting nut, then press the clamp lever inward toward the seat tube (Figure. 3-2).

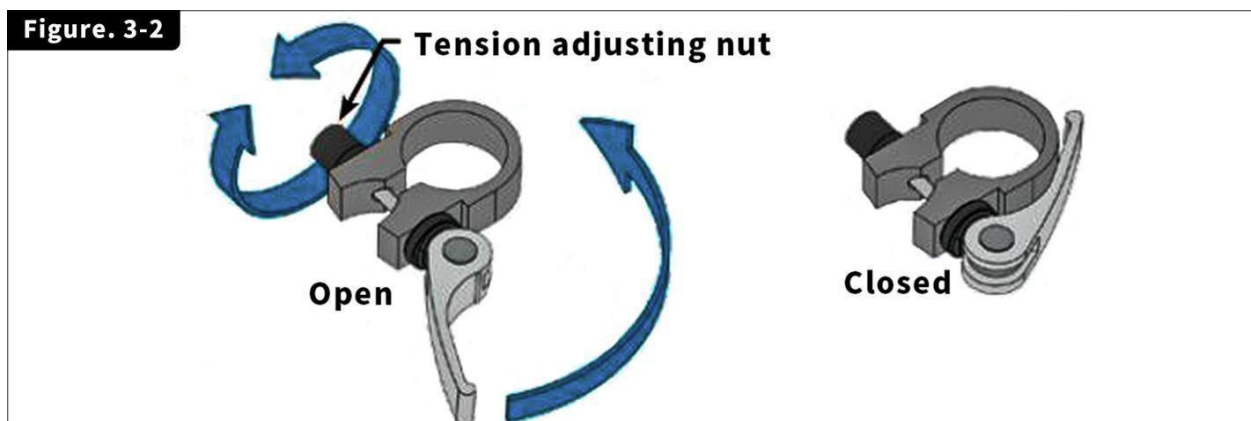

**Please Note:** If necessary, tighten the clamp by twisting the clamp handle clockwise while in the un-clamped position. Then, fold the handle inward toward the seat post. This should require a fair amount of force to ensure the seat post is held tight. If necessary, the clamp can be further tightened with a 5 mm Allen wrench while in the clamped position.



## Pedals Installation

### 1. Identify left vs right pedal

There is a "L" or "R" stamped into the axle (threaded part that looks like a screw) (Figure. 4-1)

**Please Note:** They are not the same!! Apply a small amount of grease if possible

### 2. Install the left hand pedal firstly

You will have to screw it in counter-clockwise because the threading is the reverse of a normal screw. Do this by slowly pedaling the cranks backwards. If the pedal feels stiff stop and then re-try, it should feel like a smooth motion. Do not use the wrench until you are ready to tighten it for the final few turns. Tighten it down until you can't anymore. (Figure. 4-2)

**Please Note:** Hand tight is not sufficient. Use a tool. If after riding, the threads on your crank are stripped, you have not followed these instructions. Your crank needs replacing (**this is NOT covered by warranty**).

### 3. Install the right hand pedal

this one threads in clockwise, like a normal screw. Follow the same principals as discussed in step 2 for the left pedal. (Figure. 4-3)



### 4. Wipe off any excess grease from around the crank.

## TORQUE SPECIFICATIONS

Item	N.m
Handlebars	18N.m (Trail Tracker 12N.m)
Handlebar Stem	12N.m (Trail Tracker 8N.m)
Seatpost	Quick Release
Seat	18N.m
Front Wheel	18N.m (If Applicable)
Rear Wheel	30N.m or above

## Battery Installation & Removing & Charging

### 1. Battery Installation

Turn the key (normally the keys are tied on the clamp of seat tube) to unlock position (Figure. 5-1), Line up the grooves on the battery and battery holder (Figure. 5-2), then slide the battery down, turn the key to lock position (Figure. 5-3) and remove the key.

**Please Note:** the function of lock is used to for locking the battery on frame only



### 2. Battery Removing

Do the same thing when installing but in inverse order.

### 3. Battery Charging

Finding the charging port on the battery (Figure. 5-4), connect the charger's plug to the battery charging port, then connect the other side plug to the AC outlet (120v). The LED on the charger is red color when charging, it will turn to green color when the battery is full charged. It will be 6-8 hours for full charging the battery. Remember to fully charge the battery before first riding. **Please Note:** There is a small button on the battery, press and hold the small button, you can see the remaining capacity of the battery (It is 1 red light + 3 green lights when full charged) (Figure. 5-5).

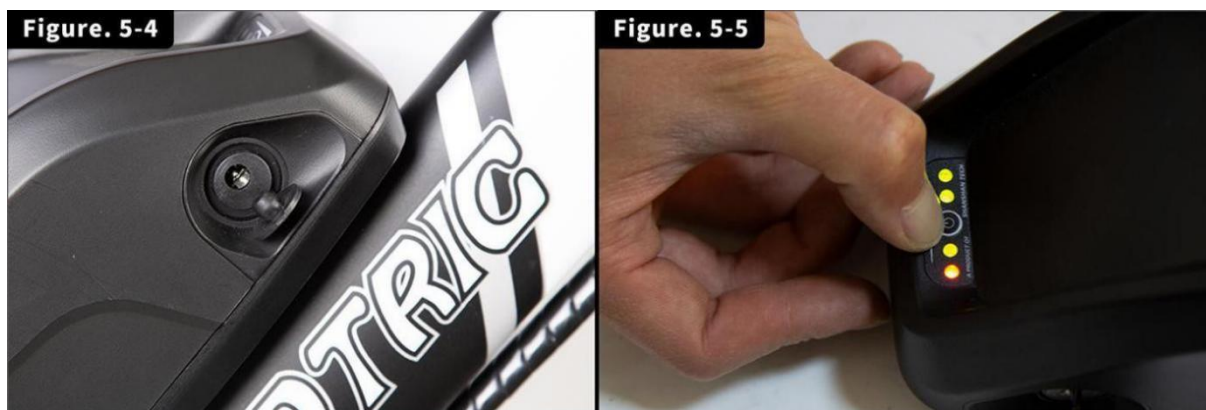

## Testing The Bike

### 1. Lighting Up The Display

Turn the key to lock position, make sure the battery is locked firmly on the frame, then press the “M” button on the handle bar and hold 3 seconds (Figure. 6-1), the display will be lighted up.

### 2. Testing The Throttle, Pedal Assist And Walk Assist Mode

The bike has 3 modes: throttle, pedal assist, walk assist. Please lift the rear wheel up, then test them separately.

**Please Note:** please make sure the the number of the PAS level is bigger than “1” (Figure. 6-2), “0” means no throttle or pedal assist.

A. Throttle: please twist the throttle, it is on the right side of the handle bar (Figure. 6-3).

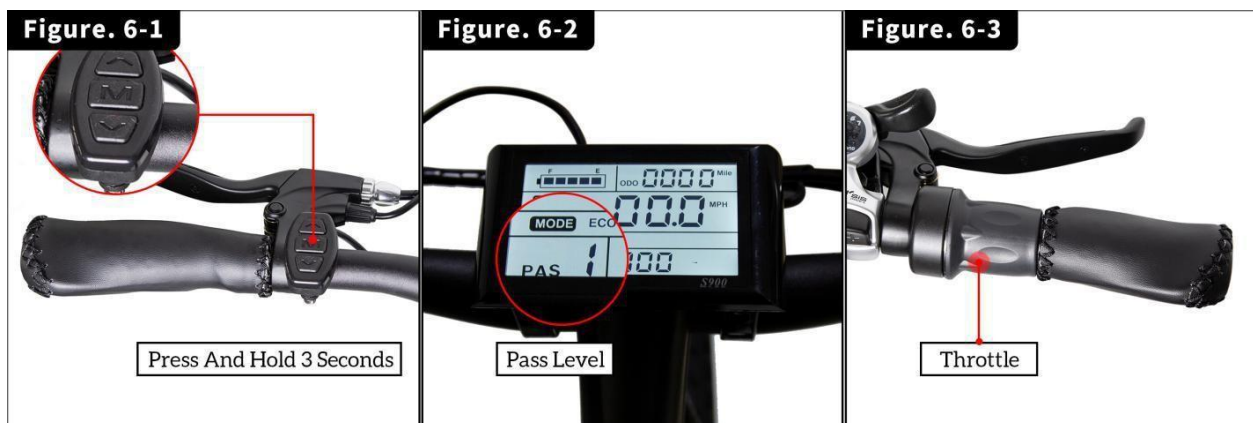

B. Pedal Assist: please lift up the rear wheel and turn the pedal by hand, the motor will work one time once you turn the crank 3/4-cycle (Figure. 6-4).

C. Walk assist: Please press the “down” button on the handle bar, the bike will go into walk assist mode (Figure. 6-5).



### 3. Testing The Brake System

Please hold the 2 brake levers on both side of the handle bar, then trying push the bike forward to make sure the bike is assembled firmly, and brakes can stop the bike properly. **Please Note:** You can adjust the tightness of the brake cable lightly by adjust the the knobs on the caliper (Figure.6-6).

4. Please note the bike's serial number(Figure. 6-7) and battery serial number(Figure. 6-8) on the last page of user manual in case of stolen or missing.

5. You are ready for riding!

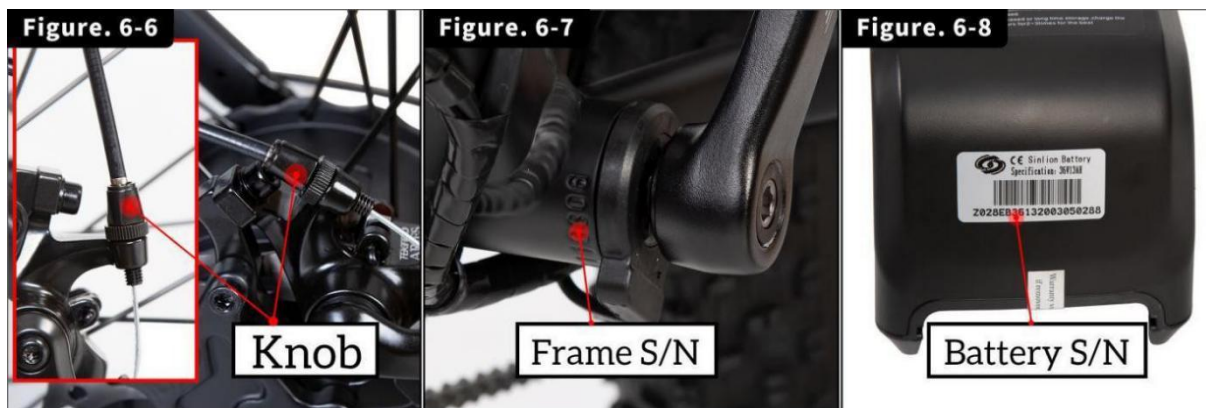

# Display Instrument Setting

## Presentation of Screen

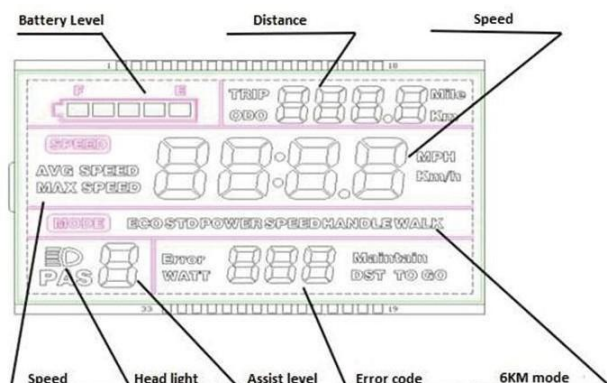

- Speed: Average SPEED/MAX SPEED
- Speed unit: KMH/MPH
- Battery level: 5 levels, voltage interval could be customized
- Head light icon : indicates when head light and back light are on (No headlight function for this bike).
- Error code : ERROR and code when there is error
- Assist level : actual assist level 0~5, 0 –no assist, 1- ECO, 2,3-STD, 4,5-POWER
- Distance: TRIP/ODO
- 6km mode

To turn the unit on, press and hold the “M” button to light up the display. A long press again “M” will switch it off. The display switches off automatically if there is no activity for five minutes (default).

## Display Setting

Short press M button to switch ODO/Trip.

Short press up or down button to change assist level, default value is level 1

Long press down button to enter walk assist mode, “walk” will show up on screen



## Display Advanced Setting

Long Press and hold the up and down button for seconds to enter the setup interface, short press up or down button to change the value, short press M button to save current value and switch to next parameter.

- **P01:** Backlight, press up or down button to change the brightness (range is 1 to 3)
- **P02:** Speed unit, press up or down button to change between MPH and KMH.
- **P03:** Voltage, press up or down button to change the voltage 24v/36v/48v. **Please don't change the default value.**
- **P04:** Sleep time interval setting, Press up or down button to change the time, range from 0 to 60 minutes. Display will sleep and cut off power after no operation on system for the selected time, the default value is 5 minutes.
- **P05:** Assist level, Press up or down button to change the level between 0(max level=3) and 1(max level=5) and 2(max level=9)
- **P06:** Wheel size, Press up or down button to change wheel size. **Please don't change the default value.**
- **P07:** Speed limit, Short press up or down button to set the speed limit from 15 to 45km/h ("45" means no limit)
- **P11:** Reset all parameters, Long press up button 5 seconds, when displays "ssss", all parameters reset to default values (except for the ODO distance)

# Troubleshooting

We full understand your feelings when you meet a problem with the bike,the best and fastest way for solving your problem is that: contact us on the website where you bought the bike,and tell us your problem in details,it is the best if you can send us some clear pics or make a video to show your problem.Every message will be replied in one businessday.

The following are some assist tips for electrical problems:

## The display can not be lighted up

Please full charging the battery(6-8 hours),the LED on the charger should be green color when the battery is full charged.

If still not work,please check the wires and battery,please make sure the connections are no loose and the battery is installed in place,then please light up the display in correct order(light up the power button on the battery,then press the “M” button and hold 3 seconds).

If still not work,we need to get a voltmeter,and do some testing:

First,please light up the power button,then test the battery output voltage(figure 7-1).If the voltage is “0”,it means there is something wrong with battery output plug,cell or fuse,please take a picture or make a video to show your testing result ,then send it to us .The customer service department will give you a solution;if the battery voltage is not “0”,but less than 32V,please full charge the battery (6-8 hours),then test it again; if the battery voltage is between 32v-42v,but the display can not be light up,it means the battery is good, we need test the other 2 plugs.

Second,please open the controller box,and find the power wire(it is black and red color) that connect the battery and controller(figure 7-2). Please test the voltage of the power wire,if it is “0”,it means the power wire need to be replaced,please take pictures,and send the pics to us.If the voltage is same as the battery,it means the power wires is good,we need to test the output voltage of the controller,it is the plug that connect the controller and display,it has 5 wires on the plug,please test the red and black wires(figure 7-3).If the voltage is “0”,it means the controller need to be replaced,please take some pictures and send them to us;if the voltage is same as the battery,it means the display need to be replaced.Please picture the testing results and send them to us,it will help us for solving your problem asap.

We have video on YouTube: <https://www.youtube.com/watch?v=zzrkBPsYjrg&t=1s>

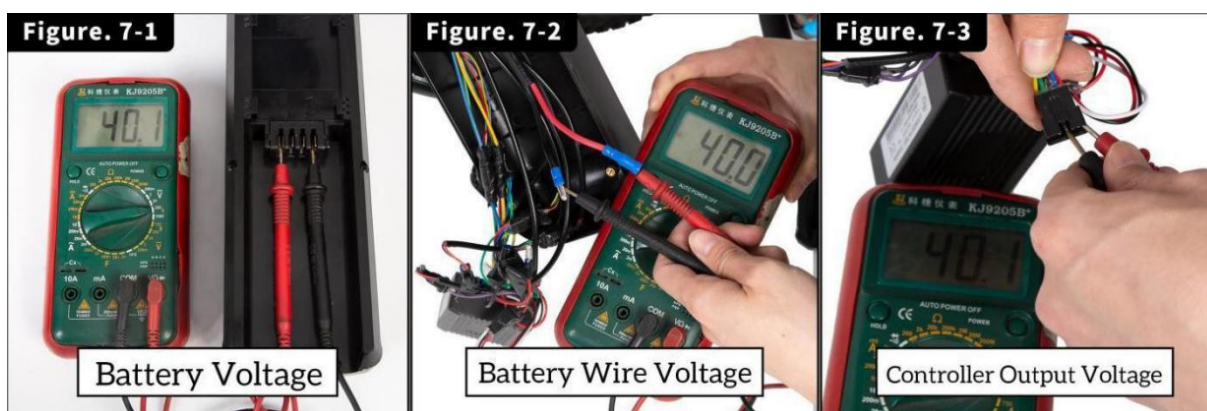

## The throttle does not work

We mean the display can be lighted up, no error codes, but the throttle does not work. The brakes have two functions when you press the brake lever: 1. it will stop the bike 2. it will cut the power of the motor.

**First**, please check the brake lever, please make sure the brake lever can be held or released fluently. If not, maybe the brake cut the power, please video your problem and send it to us. We will give you a solution.

**Second**, please make sure the number behind "PAS" is bigger "0", if the number is "0", it means no throttle or no pedal assist. Please test the pedal assist mode (please lift up the rear wheel, then turn the crank a whole cycle), and walk assist mode (press the "down" button and hold 3 seconds). If only the throttle does not work, it means the throttle needs to be replaced. Please video your testing and send the video to us. If none of the 3 modes works, we need to test the motor wire and brake sensor.

**Third**, please find the plug on the motor wire (Figure 8-1), maybe the connection is loose, please re-plug it, then restart the bike, then test all 3 modes, if still not working we need to check the brake sensor.

**Fourth**, please open the controller box (Figure 8-2), and find the 2 plugs that connect the brake levers and the controller. It is the only 2 plugs that have 2 wires on each plug (Figure 8-3). Please disconnect them, then test all 3 modes again, if they work, it means the brake sensor is defective, the brake wires need to be replaced. If still not working, it means the controller needs to be replaced, please video your problem, and send the video to us.

If still not working after replacing the brake wire or controller, please video how you do the troubleshooting, and send the video to us.

**We have a video on YouTube, the model is different, but the method is the same:**

[https://youtu.be/i\\_s9v7mw\\_zs](https://youtu.be/i_s9v7mw_zs)

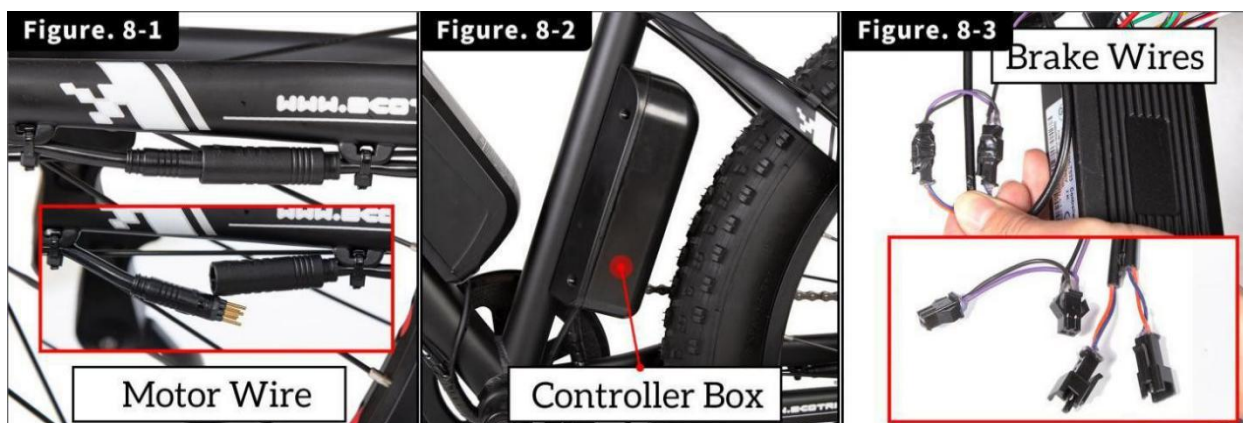

## Error Codes

When something goes wrong with system, an error code will flash on the display. Check details on attached list.

**Please note:** The motor will stop working in the event of an error. Only when the error is gone, the motor will work again. Please send us a pic to show the error code, it will help us a lot for solving your problem as soon as possible.

### Error Codes:

Error code	Definition
0	Normal
2	Short circuit protection of motor
3	Controller error
4	Throttle error
5	Motor error
8	Low battery level
9	High battery level
10	Motor hall sensor error
30	UART receive error

- 0 : Normal
- ERROR 02 : The controller or motor need to be replaced.
- ERROR 03 : The controller need to be replaced.
- ERROR 04 : Turn the throttle to the opposite direction, maybe the throttle does not return to the original position. If still not solved, the throttle need to be replaced
- ERROR 05 : Replace the controller or motor
- ERROR 08 : Please full charge the battery until the LED on the charger turns to green color (6-8 hours); if still not solved, please test the output voltage of the battery, and send us a pic to show your result.
- ERROR 09 : Please test the output voltage of the battery, and send us a pic to show your result.
- ERROR 10 : Please find the plug that connect the controller and motor, please re-plug it, maybe the connection is loose; if still not solved, please video your problem and send your video to us.
- ERROR 30 : Replace the controller or display

# Warranty Information

The warranty covers items that fail when used within their normal operating parameters. Please provide the order number when you need warranty. This warranty applies only to the original registered owner of the ECOTRIC bicycle and is not transferable.

TO ACTIVATE YOUR NEW ECOTRIC ELECTRIC BICYCLE WARRANTY, PLEASE REGISTER YOUR BIKE BY THIS LINK.

<https://www.ecotric.com/pages/warranty-registration-1>

If any part happen to be damaged during shipping, please contact us immediately after shipment arrival. ECOTRIC will send a replacement part at our expense and will work with you to fix the issue.

## Situations that are not covered by warranty

- Water Damage (wading in the water, parking in the rain)
- Refit (refit the motor, electrical system, battery, frame, fork, etc. without our authorization)
- Overloading (Riding on steep slope/load more than 265lbs)
- Artificial damage (incorrect installation/usages)
- Uncontrollable factors (Crash, falling, stolen, etc.)
- Improper use (Abusive use the bicycle in off-road terrain, mud, water, gravel or jumping from ramps, stairs or elevated ramps, or using the bike at an altitude higher than 6562 feet )
- Damages caused by natural disasters (such as earthquakes, lightning, fire, flooding and other hazards).
- Use of other components (such as charger, battery, display, or controller, **it may result in fire or death**)
- Acts in violation of laws
- Never registered your ebike or cannot provide the order number

## 18 months Limited Warranty Components (In the period of 18 months from purchase by Official Authorized Store)

- **Frame** – are warranted to be free from defects in material or workmanship for 18 months from purchase by Official Authorized Store. Paint finish is considered consumable and is not part of the warranty.
- **Motor, Display, Controller and Motor Assembly** – are warranted to be free from defects in material or workmanship for a period of 18 months from purchase by Official Authorized Store.
- **Original Battery** – are warranted to be free from defects in material or workmanship for a period of 18 months from the date of purchase as follows: full replacement during the first 12 months, while replacements needed during months 13-18 are prorated by the below link  
<https://www.ecotric.com/pages/battery-replacement-cost>

## Exclusions:

The warranty does not cover components subject to wear: Tires, inner tubes, brake lines, brake pads, wheel lining tape, fuses, etc. The other parts are Normal wear parts which are excluded from this warranty.

**Please note that for warranty issues, the customer is responsible for the cost of labor to install warrantied components.**



# Return Policy

If you buy the bike and then change your mind and simply want to return it for a refund within 30 days of receiving it, then that is fine, make sure the bike in new condition and well packed, but depending on circumstances we may charge a 10%-50% restocking fee, shipping is not refundable, and you are also responsible for returning the item to us as per our shipping guide . The returned unit must be in like-new condition, include all original packaging , accessories and documentation, any missing components may be deducted from the total refund . Any shipping damage during the ship-back may incur in a deduction from the total refund.

**Please note:** Buyer is required to get the packing box, pack the bike, and take the bike to UPS/FedEx Store when buyer want to return the bike. (Please keep the original box in case of returning if necessary). We can not accept your return request if you bought the bike for more than 30 days, but we will keep providing our best customer service.

If buyer pickup the bike locally, buyer is responsible for carrying the bike back to our warehouse.

If you buy the bike in USA, but use it in the other country or Hawaii, Alaska or Puerto Rico, PO Boxes/APO's which is out of our of delivery range. Buyer is responsible for returning the bike to original address which we shipped the bike to.

# FAQ

## **Q: How does after-sale customer service/ warranty work?**

**A:** When you have problems with your bike, please message us on the website where you bought the bike, we will reply you 1 business days. It is the best if you can describe your problem in details, and make a video to show your problem, it is the fastest way for solving your problem.

example: My bike does not work. Customer should tell us like that the display can be lighted up, but the throttle does not work. When you have electrical problems, the first thing we want to know is the display can be lighted up or not, then please provide more details about how it happens and the symptom of the problem. We will report your problem/video to our technician team, then we will give you a solution. If your bike is under warranty, we will arrange spare parts from our warehouse in USA.

## **Q: I'm tech inclined and think I can fix it myself, does that void the warranty if I do?**

**A:** No, we always like to work with and support customers who are resourceful enough to fix an issue on their own, and we will provide plenty of tech support over email to guide you through the process. It saves wasted time and expense in shipping and it can be a useful and fun learning process. Please contact us prior to attempting a DIY repair, however, as some things have non-obvious complications.

## **Q: Why the charger is hot?**

**A:** When the battery is charged, it is normal that the charger getting hot, because part of the energy is converted into heat energy when converting AC to DC. As long as there's no smell, you don't need to worry about it. However, it's better to put it in a ventilated place, because the heat will accelerate the aging of electronic components.

## **Q: What is the range of this bike?**

**A:** We try to give an exact number, but the range is related to the road conditions, rider's weight, wind resistance, there is a ramp or not and how you ride the bike. We test the bike on city road, (slight wind, flat road, rider 160lbs, with throttle and pedal assist), the range is 20 miles. If you can ride 16-23 miles, it is normal. Full charging the bike, and pump up the tyre fully will increase range.

## **Q: Can I ride the bike in rain?**

**A:** Yes, ride in moderate or light rain is no problem, please make sure the bike is bone dry before next riding, or the bike will cut-off randomly. But do not park the bike in rain and never wading in water. The battery and controller have self-protection program, they will cut the power if there is a short, but water damage will destroy the electronics of the bike.

## **Q: What is the most important thing for maintaining battery**

**A:** Remember to charge the bike in time, do not leave the bike with empty battery. Remember to charge the battery once a month if you do not use it for a long time, or the battery will be starved to death as no power. It will result in short range or display can not be lighted up.

## **Q: Do you have spare keys for the E-bike?**

**A:** Sorry, we do not have spare keys, but spare lock set. You should replace the whole lock set if you lost the keys. Remember to keep a copy of the key if necessary.

# Battery And Charger Care

The charger will charge a fully depleted battery in 6—8 hours. The indicator light on the charger will be red when battery is charging and will turn green when fully charged.

**Avoid subjecting the battery to high temperatures, such as directly under the sun, for prolonged periods of time.**

Recharge the battery before it becomes completely discharged. Completely discharging will reduce the numbers of recharging cycles during the battery's life and limit the capacity. Never store the battery in a discharged state. After much use, your battery's charge-holding capacity will decrease. If you find that your battery does not hold a sufficient charge, you should contact us to order a replacement.

If the battery will not be used for an extended period of time, charge it fully and recharge it every 2 months. Store it in a cool, dry place. Your battery is engineered with precision for high capacity and a long, useful life. Do not use it to power other electrical devices. Improper use of the battery will damage the battery and shorten its useful life and may cause fire or an explosion. If you experience unusual sounds or odors coming from the charger or the battery, unplug charger immediately and contact customer service.

## Recharge battery after every use.

- Do not disassemble or alter the battery or battery charger.
- Do not place the battery near fire or corrosive substances.
- Do not allow any liquids on or inside the battery/charger.
- Do not expose the battery/charger to extreme weather conditions.
- Do not operate the battery/charger if damaged.
- Recharge the battery only with a charger specified by the manufacturer.
- Do not use the battery/charger for any use other than its intended purpose.
- Only use the battery/charger on approved products.

**Please instruct your children to keep away from the charging place.**



# USER MAINTENANCE INSTRUCTIONS

## INSTRUCTIONS D'ENTRETIEN À L'INTENTION DE L'UTILISATEUR

Having an electric bike that breaks down or isn't running smoothly is a real pain. Here are few simple things you can do to avoid this and keep it running smoother for longer.

Electric bikes are bicycles that have additional technology to provide pedal assistance. Because they tend to get used so much more, and at greater average speeds, maintenance is a critical factor in keeping them running smoothly.

You don't need to have a fancy workshop, do these few simple things:

### **Bicycle maintenance**

Regularly check the significant touch point bolts for tightness – handlebars, seat rails, wheels etc. If any of these come off while riding, it can be dangerous! Riding with loose bolts can be an expensive and inconvenient repair.

Lube your chain regularly

Check tire pressures at least once a week. Pump up to the recommended pressures if needed.

Clean your ebike with a regular hose and / or bucket & brush. Avoid high pressure water systems as you don't want to get water in the electrics!

**Wiring.** Be careful not to knock your wiring, particularly on things such as lights, motor cables near wheels, sensor cables etc

**Batteries.** See our article on battery care and safety. Also, take care of sliding your battery in and out, so you don't bend any battery plate nodes.

The next best thing you can do for your ebike is to get it serviced regularly by a skilled mechanic - preferably one with experience working on electric bikes! Find or avoid problems before they happen.

### **MOVING AND STORAGE INSTRUCTIONS**

#### **INSTRUCTIONS VISANT LE DÉPLACEMENT ET L'ENTREPOSAGE**

There is very little to do in terms of electrics maintenance however the main thing is to take care! Particularly when you are moving your ebike in and out of cars, stairs or tricky storage places.

Prolonged Exposure to UV Rays, Rain and the Elements May Damage the Enclosure Materials, Store Indoors When Not in Use.

# Safety

## Helmet:

Always wear an approved helmet while riding your bike and follow the helmet manufacturer's instructions for it, use and care of your helmet. It is your responsibility to familiarize yourself with the laws of where you ride your Bike and to comply with all applicable laws.



## Mechanical Safety Check:

Check the condition of your Bike before every ride. Make sure no nuts, bolts or fixing are loose, with particular attention to the axle nuts and handlebar stem. Make sure the tires are correctly inflated with the recommended air pressure that is located on the side wall of every tire. Check the brakes for proper operation. You must take your bike in to be serviced and checked by a qualified bike mechanic before 100 miles (161 kilometers) of riding. This is a standard good practice for any new bike as cables will stretch and components will "bed in". The service must include spoke tension for both front and rear wheels.

## Your First Ride:

When you buckle on your helmet and go for your first ride, be sure to pick an area away from cars, other cyclists, obstacles or other hazards in order to become familiar with the controls, features and performance of your new Bike.

## Additional Passengers:

The Bike bikes are designed for one passenger only (excluding Tandems). DO NOT carry any additional passengers on the front or rear of the bike.

## Weight Capacity:

This Electric Bikes are designed with a maximum weight capacity of 265 pounds for all models. The rear rack maximum weight capacity of a Bike (if applicable) is 25 pounds. Exceeding the maximum weight capacity can result in damage of the bike which can lead to serious injury.

## Tires & Wheels

Make sure tires are correctly inflated. Check by putting one hand on the saddle, one on the intersection of the handlebars and stem, then bouncing your weight on the bike while looking at tire deflection. Compare what you see with how it looks when you know the tires are correctly inflated; and adjust if necessary. Tires in good shape? Spin each wheel slowly and look for cuts in the tread and sidewall. Replace damaged tires before riding the bike. Wheels true? Spin each wheel and check for brake clearance and side-to-side wobble. If a wheel wobbles side to side even slightly, or rubs against or hits the brake pads, take the bike to a qualified bike shop to have the wheel trued.



# General Warning

Like any sport, bicycling involves risk of injury and damage. By choosing to ride a bicycle, you assume the responsibility for that risk, so you need to know — and to practice— the rules of safe and responsible riding and of proper use and maintenance. Proper use and maintenance of your bicycle reduces risk of injury.

Your electric bicycle is designed for use by persons 16 years old or older. Riders must have the physical coordination, reaction time and mental capability to ride and manage traffic, road conditions, sudden situations and also respect the laws governing bicycle use where they ride, regardless of age. If you have an impairment or disability such as a visual impairment, hearing impairment, physical impairment, cognitive/language impairment, or a seizure disorder, consult your physician before riding any bicycle.

## A special note for parents

As a parent or guardian, you are responsible for the activities and safety of your child, and that includes making sure that the bicycle is properly fitted to the child; that it is in good repair and safe operating condition; that you and your child have learned and understand the safe operation of the bicycle; and that you and your child have learned, understand and obey not only the applicable local motor vehicle, bicycle and traffic laws, but also the common sense rules of safe and responsible bicycling. As a parent, you should read this manual, as well as review its warnings and the bicycle's functions and operating procedures with your child, before letting your child ride the bicycle.



Make sure that your child always wears an approved bicycle helmet when riding; but also make sure that your child understands that a bicycle helmet is for bicycling only, and must be removed when not riding. A helmet must not be worn while playing, in play areas, on playground equipment, while climbing trees, or at any time while not riding a bicycle. Failure to follow this warning could result in serious injury or death.

Your electric bicycle is for use by persons 16 years old and older, only. Do not let a child younger than 16 years old ride the bicycle.

# Electrical Parameters

Model	FAT26S900-MB-XXX FAT26S900-BL-XXX FAT26S900-O-XXX (XXX represents any alphanumeric character)
Motor	36V 500W
Type of Motor	Brush-less Hub motor
Battery	36V12.5AH
Type of Battery	Li-ion Battery
Charging Temperature Range	32-104°F
Discharge Temperature Range	14-113°F
Charger Output	42V DC MAX. 2.0A
Range Per Charging	18-23 miles
Maximum Speed	20 MPH
Maximum Loading	265 LBS
Dimensions	75.6x45.2x25.2 inch
Folding Dimensions	NO Folding
Weight	55 LBS
Maximum Elevation	6562 feet
Storage Temperature Range	14-113°F

# The Universal Wiring Diagram

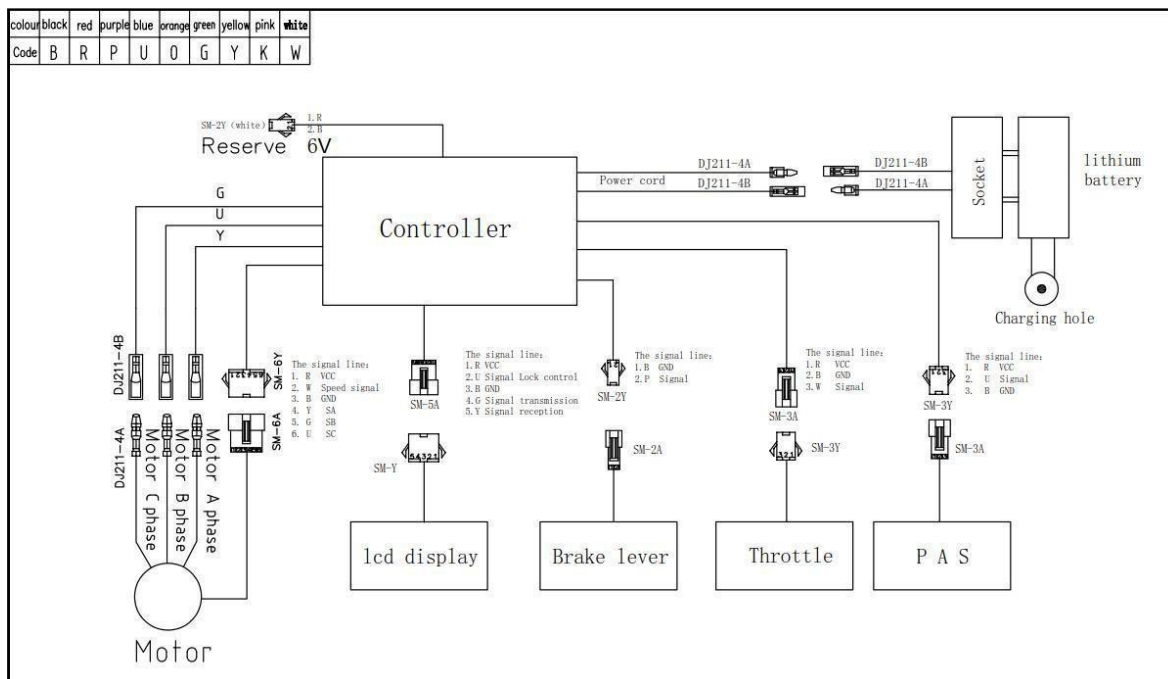

This wiring diagram is only for reference, if any question you have, please contact customer service for any repair.

## Recording Your Ecotric Bike Info

BICYCLE SERIALNUMBER: \_\_\_\_\_

BATTERY SERIAL NUMBER: \_\_\_\_\_

MODEL: \_\_\_\_\_

COLOR: \_\_\_\_\_

DATE OF PURCHASE: \_\_\_\_\_

DEALER'S NAME: \_\_\_\_\_

DEALER'S PHONE: \_\_\_\_\_

DEALER'S EMAIL: \_\_\_\_\_