



PHENYX PRO[®]

PTM-11/22/33 Series

UHF Wireless Mono In-Ear Monitor System



OWNER'S MANUAL

*Thank you for purchasing the Phenyx Pro PTM-11/22/33 Series.
For the best results and the utmost satisfaction with your new unit,
please read this manual carefully to ensure proper operation,
and keep it for future reference. For more information,
please visit our store: www.phenyxpro.com*

Table of Contents

System Description.....	2
System overview.....	2
System features.....	2
System components.....	2
Functions of Parts.....	3
Transmitter.....	3
Bodypack receiver.....	5
Operation Guidance.....	6
Step 1: Connect the transmitter and power it up.....	6
Step 2: Turn on the receiver.....	7
Step 3: Set up the transmitter.....	7
Step 4: Pair up the transmitter and receiver.....	7
Troubleshooting.....	8
Specification.....	9
Technical Support & Warranty Information.....	12

System Description

System overview

The Phenyx Pro PTM-11/22/33 Series provides a convenient audio monitoring experience. No matter where you stand or how loud the rest of your band and the environment are, you can hear your crystal-clear monitor mix on stage while moving and dancing as you like. The beginner-friendly mono design immerses you in your content and frees you from wire entanglement on stage. The mono wireless transmitter features left/right inputs and left/right LOOP outputs to enable more connections and flexible setup. You can enjoy a rich personal monitoring experience in stages, gigs, bands, studios, etc.

System features

- Crystal-clear mono audio without latency lasts throughout your whole performance.
- Selectable UHF frequency design with one-touch selection for your desired frequency to avoid interference. (The PTM-11/22 has 50 adjustable frequency groups, and the PTM-33 has 25 frequency groups.)
- Multiple stand-alone mixes (1 mix for PTM-11, 2 mixes for PTM-22, and up to 4 mixes for PTM-33) offer a flexible and diverse monitoring experience.
- The LOOP OUT design for your flexible routing operation.
- One transmitter base unit can add as many bodypack receivers as you need.
- The PAD button of the transmitter (only for PTM-11/22) lowers the input gain to prevent loud input sources from overloading and clipping the preamplifier.
- Fuss-free synchronization process through IR sync.
- Rugged-built receivers and bodypacks with a sleek design.
- Rack-mountable with brackets included in the package.
- Up to 164ft/50m free operation range.

System components

Your system comes with a combination of the following components.

Transmitter

PMT-11	Single In-Ear Monitor Transmitter
PMT-22	Dual In-Ear Monitor Transmitter
PMT-33	Quad In-Ear Monitor Transmitter

Receiver

PMR-2	Bodypack Receiver
-------	-------------------

Accessories

ANTB-500	Antennas for 500MHz UHF Band
ANTB-900	Antennas for 900MHz UHF Band
PTA-01	Power Adapter
PTA-03	Carrying Case
	Earphone
	AA Batteries
	Antenna Rackmount Kit
	User's Manual

Functions of Parts

Transmitter

PMT-11

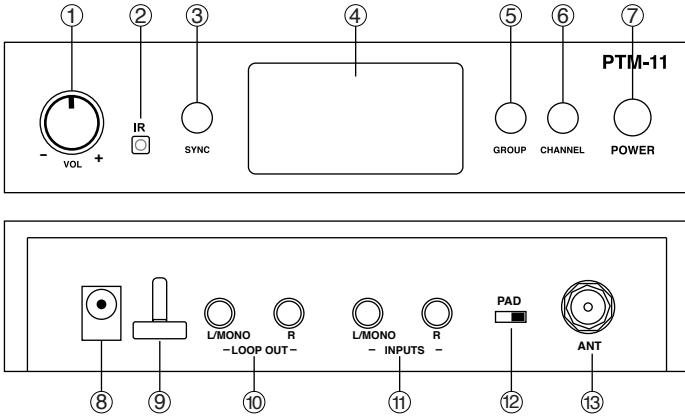

PMT-22

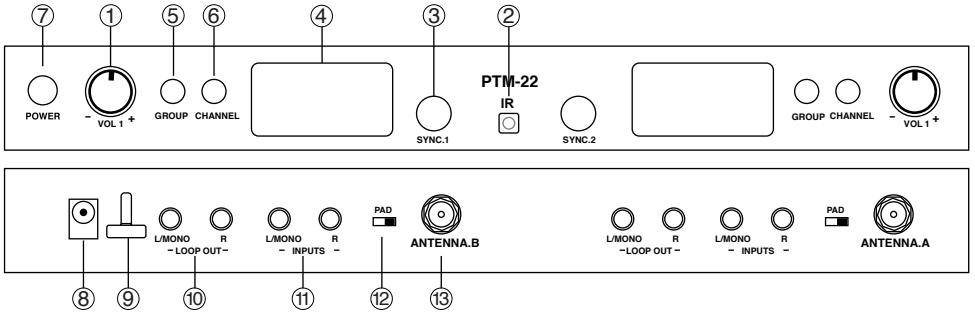

PMT-33

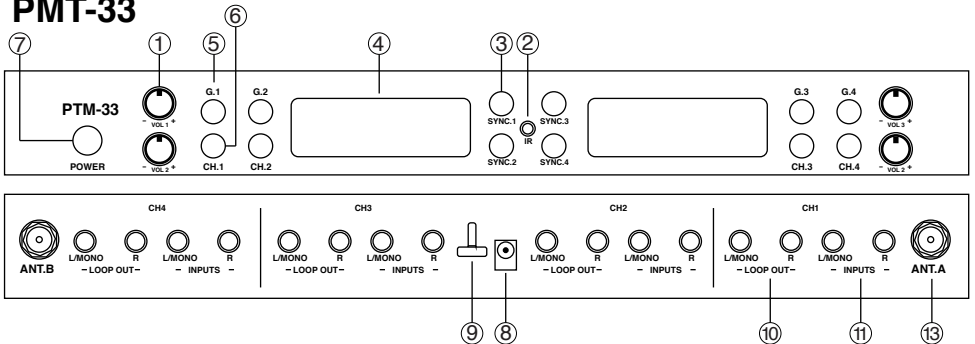

• Front panel

- ① **Volume control:** Adjust the input level of the audio signal from microphones, mixers, and other devices.
- ② **IR window:** For infrared synchronization setup.
***NOTE: Please short press (tap) the Sync button to initiate IR synchronization (The “Sync” indicator will flash on the LCD during the sync process and disappear when the synchronization is finished or fails due to a timeout).**
- ③ **Sync button:** Short press (tap) this button to initiate the IR synchronization.
- ④ **LCD display:** Display system information.
- ⑤ **Group button:** Short press (tap) this button to select the group/band number for a frequency.
- ⑥ **Channel button:** Short press (tap) this button to select the channel number for a frequency.
- ⑦ **Power button:** Short press (tap) this button to power the unit on, while long press it for 2 seconds to power the unit off. When it is on, the LCD screen and the power button light up.

• Rear panel

- ⑧ **Power jack**
- ⑨ **Adapter cord tie-off:** For managing cable.
- ⑩ **LOOP OUT jacks (TS, unbalanced):** Use the unbalanced 1/4” TS cable to connect the LOOP output jacks to send a copy of the audio signal to an external device, such as stage monitors, personal monitors, recording devices, etc.
- ⑪ **Audio Input jacks (TS, unbalanced):** Use the unbalanced 1/4” TS cable to connect the audio input jacks to the mixer monitor output or other signal-sending devices for pre-fader monitoring or post-fader monitoring.
- ⑫ **PAD switch (only for PMT-11/22):** PADING the input gain for 12dB. The default setting of 0 dB will have no effect on gain. (The PMT-33 has no such function.)
- ⑬ **Antenna jack**

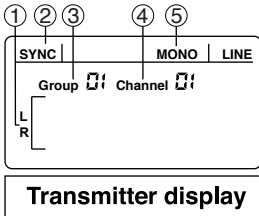

- ① **AF signal indicator:** For indicating the input audio signal of the left and right inputs.
- ② **RF signal indicator:** The “Sync” indicator flashes during the IR synchronization process and disappears when it is finished or fails.
- ③ **Group number**
- ④ **Channel number**
- ⑤ **Mono indicator:** For indicating the mono mode

Bodypack receiver

PMR-2

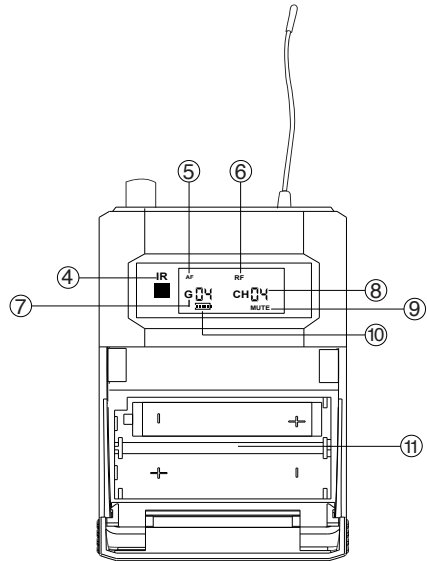
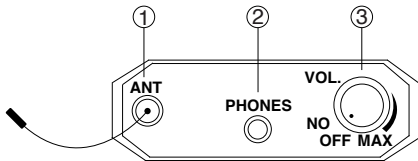

- ① **Antenna**
- ② **PHONE jack**
- ③ **Power knob:** Twist the knob to power the receiver on and off, and also to increase/decrease the volume.
- ④ **IR window:** For infrared synchronization setup.
*NOTE: Please vertically aim the IR window on the bodypack receiver to that of the transmitter for pairing them up.
- ⑤ **Audio signal indicator:** It flashes to indicate the audio signal level.
- ⑥ **RF signal indicator:** For indicating RF signal strength between the bodypack receiver and transmitter.
- ⑦ **Group number**
- ⑧ **Channel number**
- ⑨ **MUTE indicator:** To indicate that the receiver receives no RF signal. It appears when the bodypack receiver is not paired up with the transmitter successfully.
- ⑩ **Battery light:** For indicating the battery status.
- ⑪ **Battery compartment:** Install batteries with the correct polarity.

Operation Guidance

Step 1: Connect the transmitter and power it up

1 - Use 1/4" TS cables to connect the monitor/auxiliary outputs of the mixer or other signal-sending devices to the transmitter inputs.

***NOTE:** There are stereo inputs and outputs for the transmitter to mix different audio sources, but there is no stereo function that the transmitter sends signals to bodypack receivers. Please connect the L/MONO jack if you need to send only one mono signal.

2 - Use 1/4" TS cables to connect the LOOP OUT jacks to signal-receiving devices.

***NOTE:** If you want to send a signal (e.g., AUX 1 signal) to all channel receivers, please connect the signal-sending device to a LOOP OUT left/right jack and then daisy chain this signal to other channels, according to the sample below.

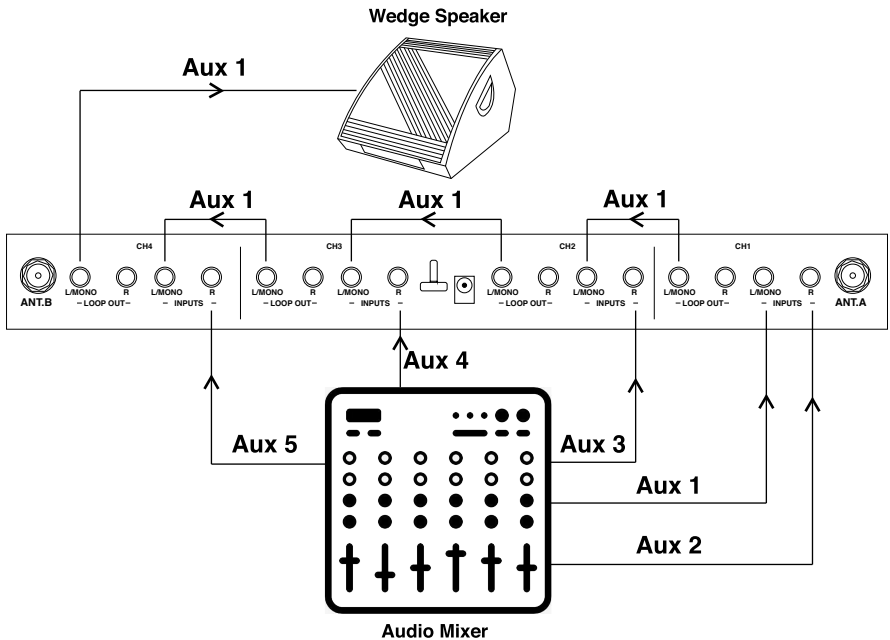

3 - Connect the antenna to the transmitter via the ANT jack.

4 - Connect the power supply to the transmitter via the power jack, and tap the power button to turn it on. And turn on other devices.

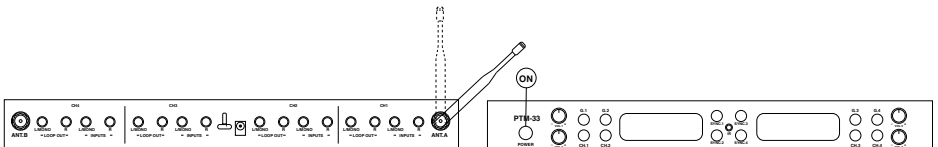

Step 2: Turn on the receiver

- 1 - Install fresh batteries with the correct polarity.
- 2 - Connect an earphone to the bodypack receiver.
- 3 - Twist the power knob to power on the bodypack and adjust the volume.

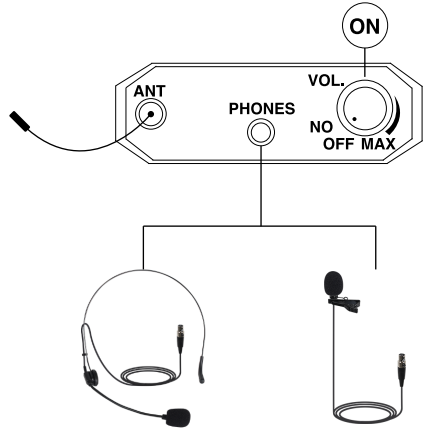
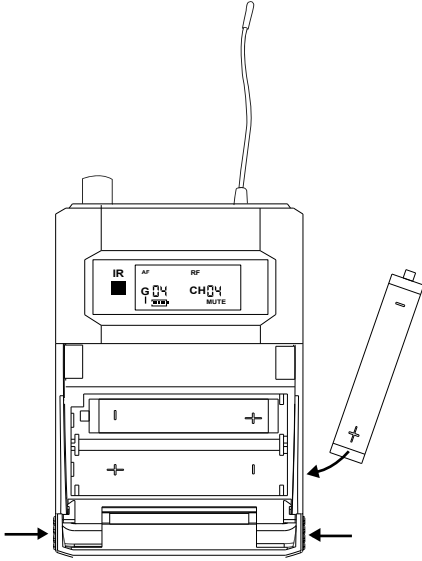

Step 3: Set up the transmitter

Short press (tap) the Group button and Channel button to select the desired frequency to operate.

Step 4: Pair up the transmitter and receiver

- 1 - Short press (tap) the Sync button to initiate the IR synchronization.
- 2 - Vertically aim the IR window of a bodypack receiver to that of the transmitter.

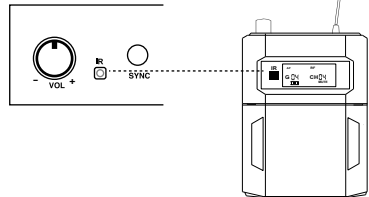
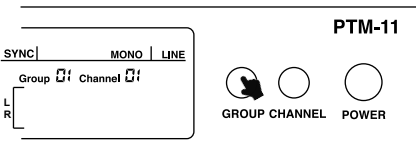

Troubleshooting

Problem	Solution
Distorted audio/static noises	<ul style="list-style-type: none">• Select another frequency to try again• Place the transmitter higher or move it to another place• Check the volume levels at the transmitter/receiver and verify that it is not too loud• Make sure the batteries in the receiver are fresh Check that all cables are fully inserted
No sound from a receiver	<ul style="list-style-type: none">• Adjust the volume level of the transmitter and receivers• Check that the receiver is on and the earphone is properly connected to the receiver• Make sure the transmitter and receivers are linked to the same group and channel; otherwise, pair them up again• Connect a new earphone to the receiver
High noise floor	<ul style="list-style-type: none">• Adjust the proper amount of gain of input audio signals
The MUTE indicator on the receiver display after synchronization	<ul style="list-style-type: none">• Vertically pair up the receiver and transmitter until the MUTE indicator disappears.• The MUTE indicator flashes to indicate cutoffs; it is better to change the frequency of the receiver and vertically pair it with the receiver again.

Specification

• System

Frequency Range	530MHz - 580MHz; 902Mhz - 928MHz (Depends on local regulations)
Transmitter Output Level	10dBm
Operating Range	50m/164ft
Audio Frequency Response	50Hz - 16KHz (+/- 3dB)
Harmonic Distortion	<1% (+/- 30KHz deviation)
Dynamic Range	> 90dB
Operating Temperature	- 10° — + 50°

• Transmitter

Max Audio Input Level	+6dBV
Gain Adjustment Range	40dB
Input Impedance	6.8KΩ
Power Requirements	12 - 18V DC, 350mA

• Bodypack Receiver

Audio Output Level	80mW
Sensitivity	90dBm for 30dB SINAD, typical
Power Requirements	2 AA alkaline or recharging batteries
Battery Life	>6 hours

• 500MHz Frequency Version Frequency List

PMT-11	Channel A	Group 1: 530.05 — 532.3MHz	Each group has 10 channels with a 0.25MHz increment.
		Group 2: 532.55 — 534.8MHz	
		Group 3: 535.05 — 537.3MHz	
		Group 4: 537.55 — 539.8MHz	
		Group 5: 540.05 — 542.3MHz	
PMT-22	Channel A	Group 1: 530.05 — 532.3MHz	
		Group 2: 532.55 — 534.8MHz	
		Group 3: 535.05 — 537.3MHz	
		Group 4: 537.55 — 539.8MHz	
		Group 5: 540.05 — 542.3MHz	
	Channel B	Group 6: 542.55 — 544.8MHz	
		Group 7: 545.05 — 547.3MHz	
		Group 8: 547.55 — 549.8MHz	
		Group 9: 550.05 — 552.3MHz	
		Group 10: 552.55 — 554.8MHz	
PMT-33	Channel A	Group 1: 542.55 — 554.8MHz	
		Group 2: 545.05 — 547.3MHz	
		Group 3: 547.55 — 548.55MHz	
	Channel B	Group 4: 548.8 — 549.8MHz	
		Group 5: 550.05 — 552.3MHz	
		Group 6: 552.55 — 554.8MHz	
	Channel C	Group 7: 567.55 — 569.8MHz	
		Group 8: 570.05 — 572.3MHz	
		Group 9: 572.55 — 573.55MHz	
	Channel D	Group 10: 573.8 — 574.8MHz	
		Group 11: 575.05 — 577.3MHz	
		Group 12: 577.55 — 579.8MHz	

• 900MHz Frequency Version Frequency List

PMT-11	Channel A	Group 1: 902.35 — 904.6MHz	Each group has 10 channels with a 0.25MHz increment.
		Group 2: 904.85 — 907.1MHz	
		Group 3: 907.35 — 909.6MHz	
		Group 4: 909.85 — 912.1MHz	
		Group 5: 912.35 — 914.6MHz	
PMT-22	Channel A	Group 1: 902.35 — 904.6MHz	
		Group 2: 904.85 — 907.1MHz	
		Group 3: 907.35 — 909.6MHz	
		Group 4: 909.85 — 912.1MHz	
		Group 5: 912.35 — 914.6MHz	
	Channel B	Group 6: 915.35 — 917.6MHz	
		Group 7: 917.85 — 920.1MHz	
		Group 8: 920.35 — 922.6MHz	
		Group 9: 922.85 — 925.1MHz	
		Group 10: 925.35 — 927.6MHz	
PMT-33	Channel A	Group 1: 902.35 — 904.6MHz	
		Group 2: 904.85 — 907.1MHz	
		Group 3: 907.35 — 908.35MHz	
	Channel B	Group 3: 908.6 — 909.6MHz	
		Group 4: 909.85 — 912.1MHz	
		Group 5: 912.35 — 914.6MHz	
	Channel C	Group 6: 915.35 — 917.6MHz	
		Group 7: 917.85 — 920.1MHz	
		Group 8: 920.35 — 921.35MHz	
	Channel D	Group 8: 921.6 — 922.6MHz	
Group 9: 922.85 — 925.1MHz			
Group 10: 925.35 — 927.6MHz			

Technical Support & Warranty Information

Our warranty to you:

Phenyx Technology ("Phenyx") warrants Phenyx products against evident defects in material and workmanship for a period of one year from the date of original purchase for use. This warranty is valid exclusively in the US and applies only to the original owner. If you discover a defect covered by this warranty, Phenyx will repair or replace the product at our sole discretion using new or refurbished components. Performance of repairs or replacements under this Warranty is subject to registration of your product at www.phenyxusa.com/registerproduct.

Product failures not covered by this warranty:

This warranty covers defects in manufacturing that arise from the correct use of the device. It is limited to defects in materials or workmanship and does not cover electrical or mechanical damage resulting from abuse, misuse, unauthorized modification, lack of reasonable care, extreme heat, cold, damage due to natural forces, or corrosive environments. This warranty does not cover the normal wear and tear on covers, housing, connectors, and accessories.

Limits of liability:

If your Phenyx product fails or does not perform as warranted, your sole recourse shall be to replace or repair it as described above. Phenyx will not be liable to you or anyone else for any damages that result from the failure of this product. These damages include, but are not limited to, the following: lost profits, lost savings, lost data, damage to other equipment, and incidental or consequential damages arising from the use of or inability to use this product. IN NO EVENT PHENYX SHALL BE LIABLE FOR MORE THAN THE AMOUNT OF YOUR PURCHASE PRICE, NOT TO EXCEED THE CURRENT LIST PRICE OF THE PRODUCT.

How to obtain service under this warranty:

If you are receiving a system that is defective or you have any questions regarding operation or warranty cover, please contact us at support@phenyxpro.com with any questions or concerns and a Phenyx Pro representative will contact you to provide assistance. You can also reach out to us through Facebook page: www.facebook.com/phenyxusa/ or our official website: www.phenyxpro.com