



OUR ROOTS RUN DEEP. SINCE 1918

How to Build a Vertical Herb Planter

Watch the how-to video at:

<http://bonnieplants.com/library/how-to-build-a-vertical-herb-planter/>



Love the taste of fresh herbs? This vertical herb planter lets you grow them all in one convenient place – right outside your door! With removable shelves that can be easily left off for taller growing spaces, this simple project can be completed before lunchtime. We chose to build ours out of naturally long-lasting cedar, which will weather to a beautiful rustic look. Cut the lumber yourself if you have some woodworking experience, or make it easy by having the boards pre-cut at your local home improvement store.

DETAILS:

Estimated Time: 3 hours*

** less if you have wood pre-cut*

Difficulty: Easy to moderate

Approximate Cost (not including plants): \$300 if using cedar, \$110 if using treated lumber

HOW-TO INSTRUCTIONS

Design by Chris Hill

List of Materials:

- 1 – 1 x 2 x 8 board
- 1 – 1 x 4 x 8 board
- 2 – 1 x 6 x 8 boards
- 6 – 1 x 6 x 8 tongue & groove boards
- 2 – 1 x 8 x 8 boards
- 1 – 2 x 4 x 8 board
- 2 – 2 x 10 x 10 boards
- 1 ¼-inch deck screws (68)
- 2 ½-inch deck screws (18)
- sealer (optional)
- 12 – 18 herb plants, depending on varieties (see tags for spacing requirements)

List of Tools:

- miter saw or circular saw*
- drill/driver
- clamps
- square
- measuring tape

** or can have lumber pre-cut at home improvement store per dimensions in Parts List*

Parts List (see Cutting Diagram below):

Part	Quantity	Size
Legs	4	1 1/2 x 9 1/4 x 59 1/4
Leg braces	2	1 1/2 x 3 1/2 x 23
Leg brace supports	2	3/4 x 3 1/2 x 19
Cleats	14	3/4 x 1 1/2 x 5 1/2
Back slats	6	5/8 x 5 1/2 x 50
Back supports	3	3/4 x 5 1/2 x 33 1/2
Bottom support	1	1 1/2 x 3 1/2 x 30 1/2
Top shelf	1	3/4 x 5 1/2 x 30 1/2
Shelves	6	3/4 x 7 1/4 x 30 1/2

INSTRUCTIONS:

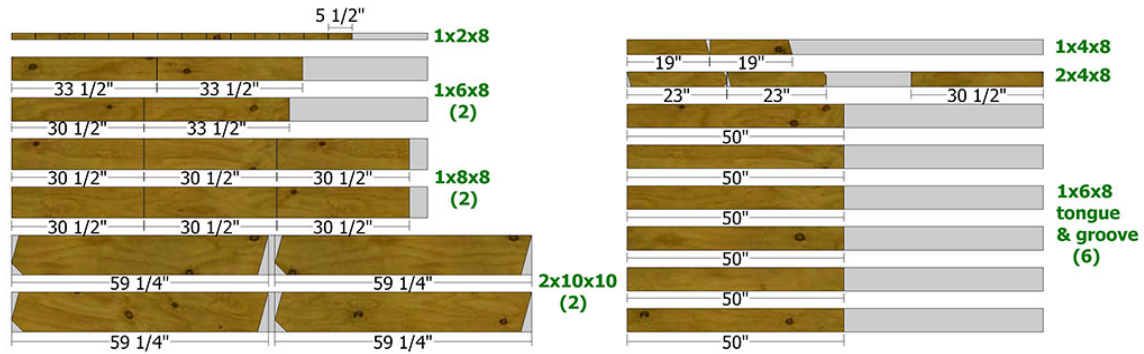

Cutting Diagram

Use the **Parts List** and **Cutting Diagram** as references for part dimensions. Cut the parts as needed for each step. If desired, apply a sealer to the bottoms and tops of the **Legs** to help keep moisture out.



Figure 1

Use the layout in **Figure 1** to create the **Legs** (make four).

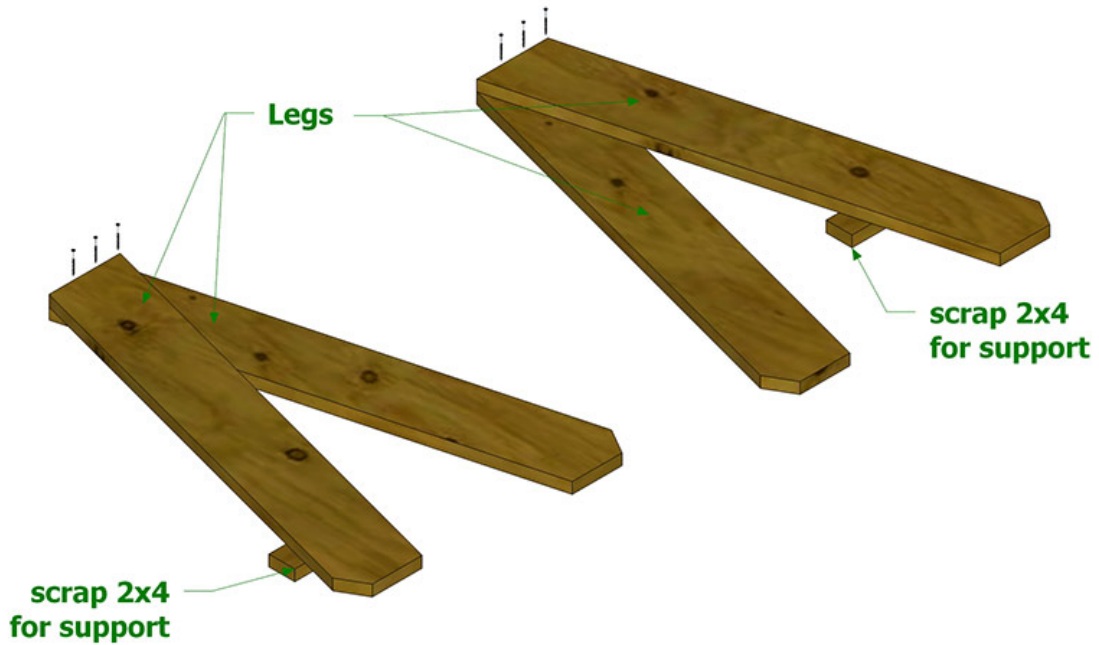

Figure 2

Position the top ends (only one miter cut) of the **Legs** flush as shown in **Figure 2** and attach using 2 1/2-inch deck screws.

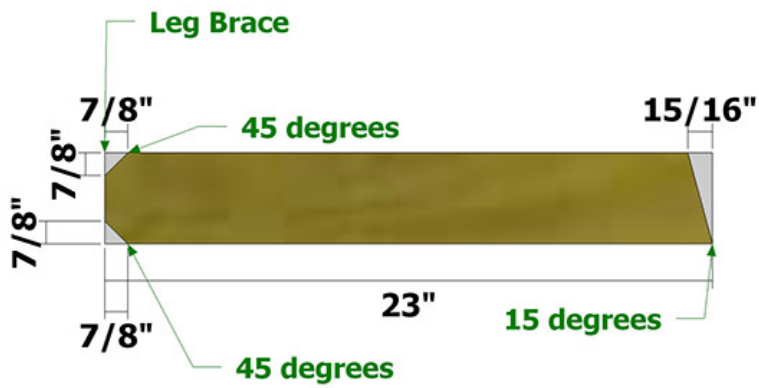

Figure 3

Use the layout in **Figure 3** to create the **Leg Braces**.

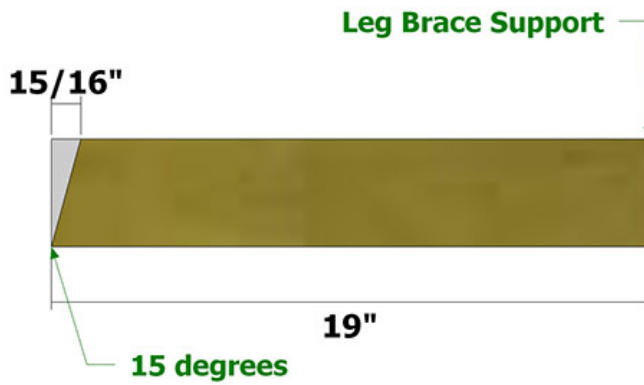

Figure 4

Use the layout in **Figure 4** to create the **Leg Brace Supports**.

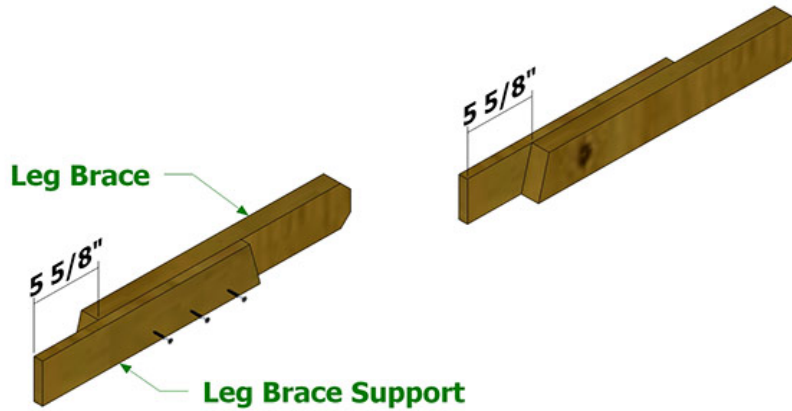

Figure 5

Position the **Leg Braces** and **Leg Brace Supports** as shown in **Figure 5** and attach using 1 1/4-inch deck screws.

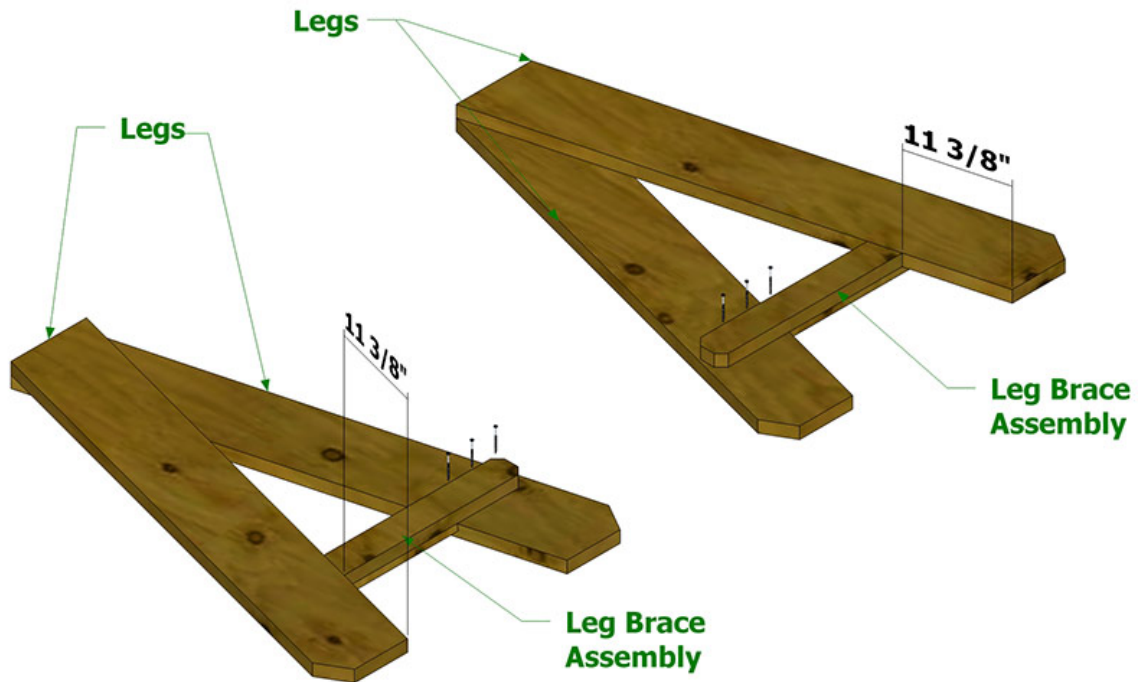

Figure 6

Position the **Leg Brace Assemblies** as shown in **Figure 6** and attach using 2 1/2-inch deck screws.

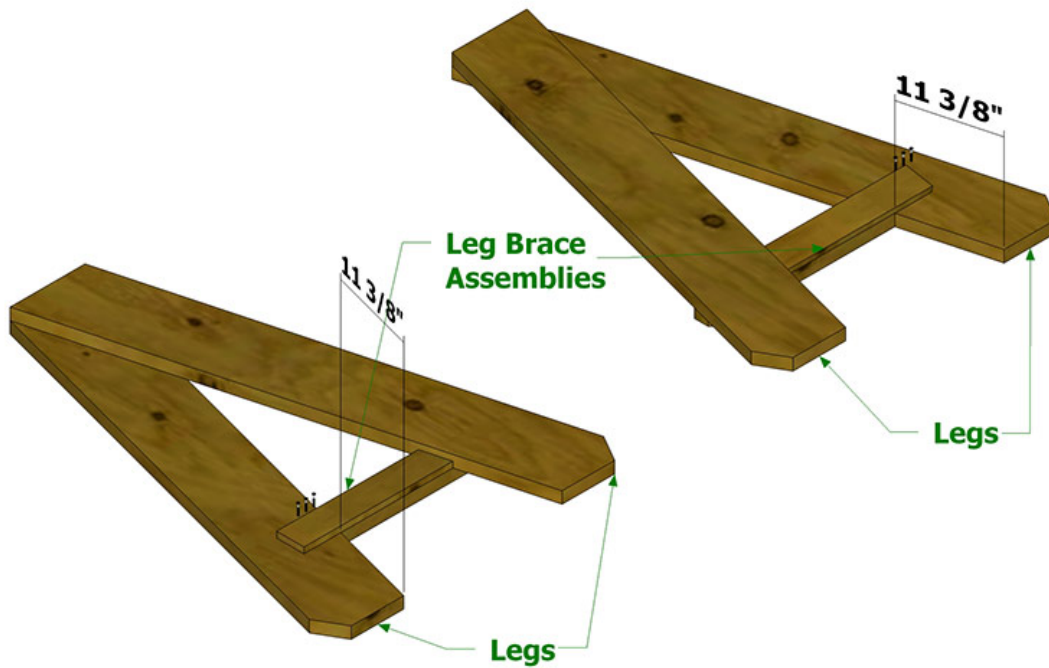

Figure 7

Flip the assemblies over as shown in **Figure 7** and attach using 1 1/4-inch deck screws.

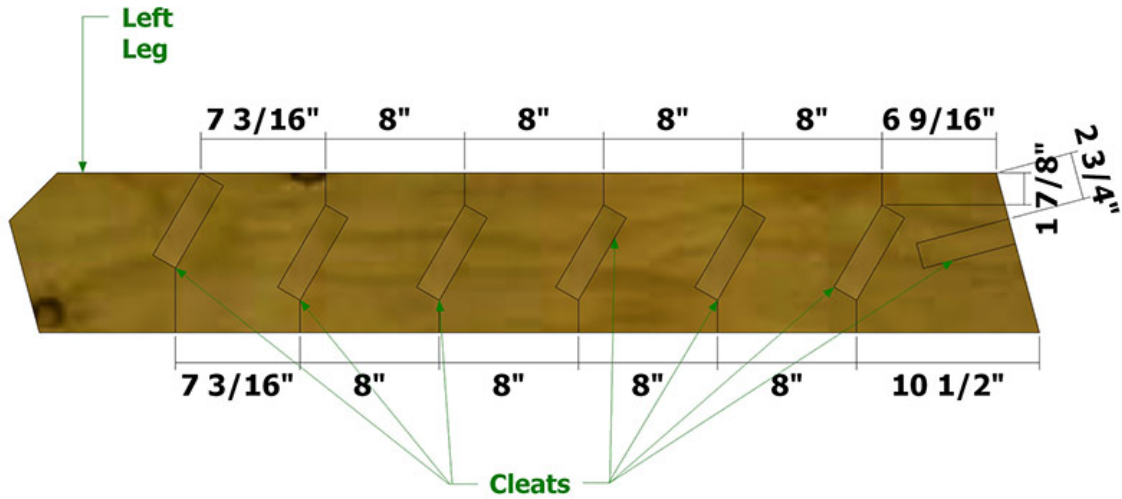

Figure 8

Use the layout in **Figure 8** as a guide for positioning the **Cleats** on the left leg.

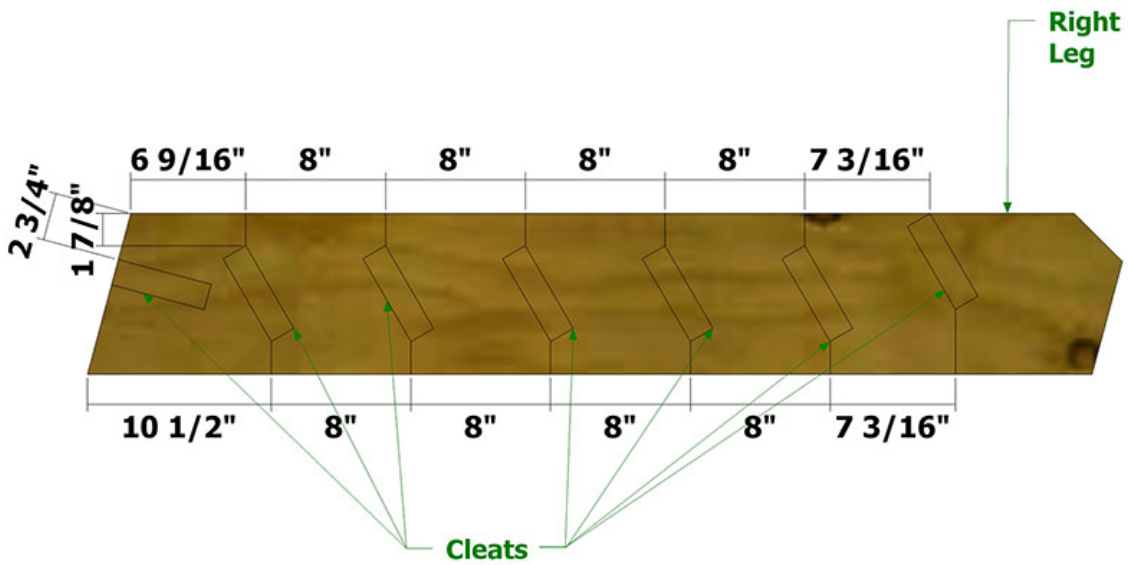

Figure 9

Use the layout in **Figure 9** as a guide for positioning the **Cleats** on the right leg.

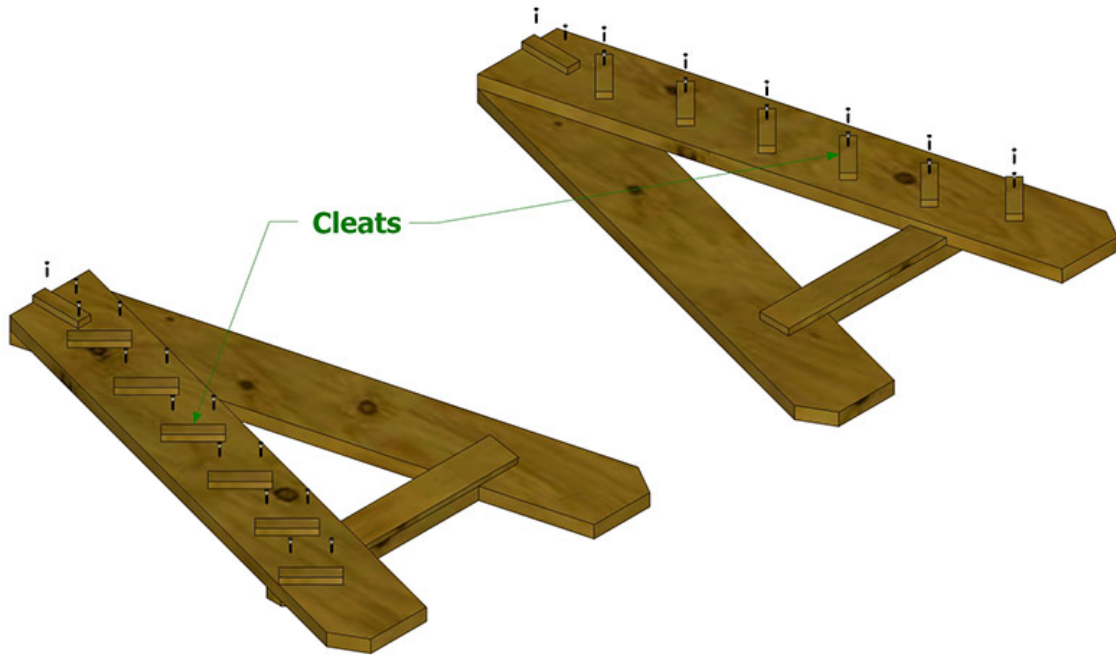

Figure 10

Attach them to the **Legs** as shown in **Figure 10** using 1 1/4-inch deck screws.

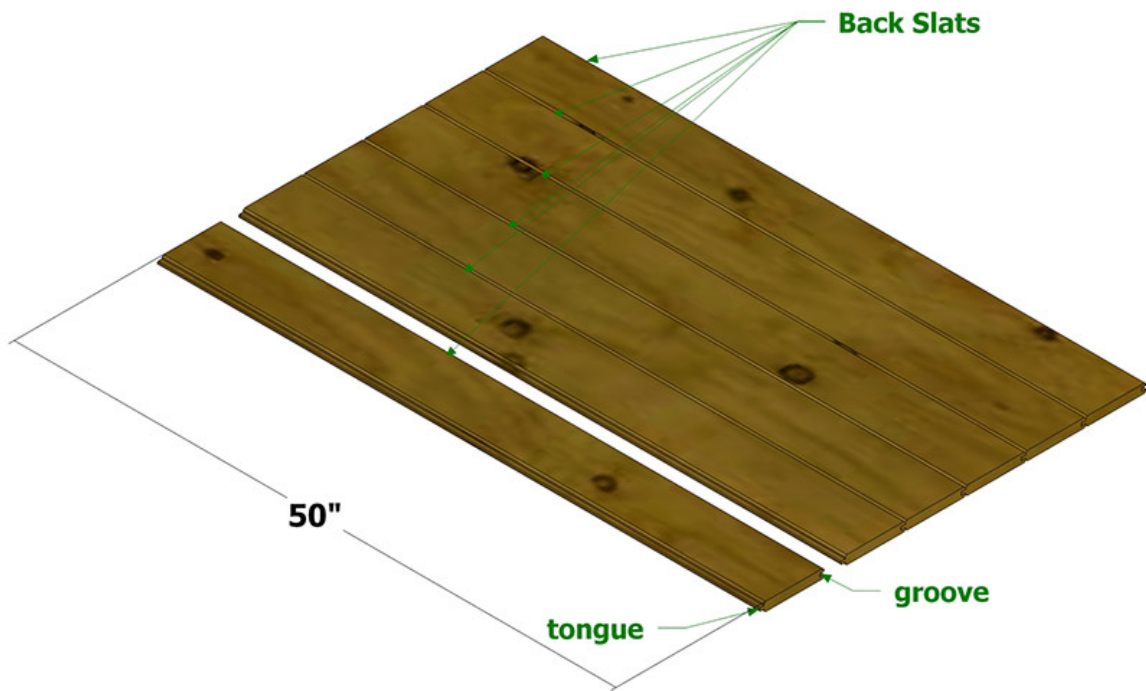

Figure 11

Create a large panel with the **Back Slats** by inserting the tongue portion of one part into the groove portion of another as shown in **Figure 11**. Once in place, measure the width of the panel, and adjust the length of the **Back Supports** if needed to make sure they overlap the sides of the panel by 1 1/2 inches on each side.

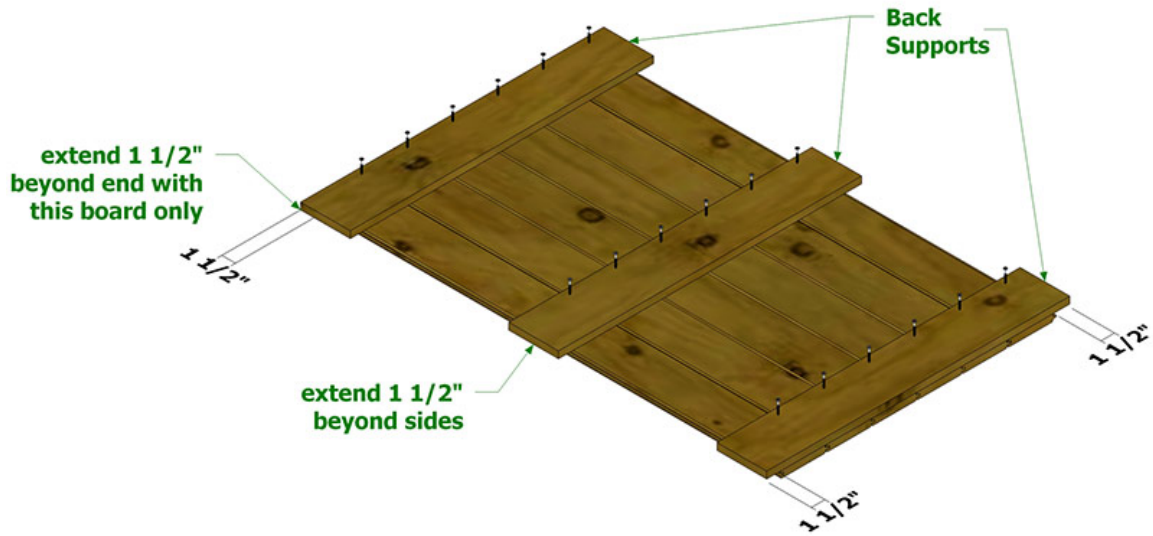

Figure 12

Position the **Back Supports** as shown in **Figure 12** and attach using 1 1/4-inch deck screws. Make sure that only one **Back Support** extends beyond the end of the **Back Slats** by 1 1/2 inches.

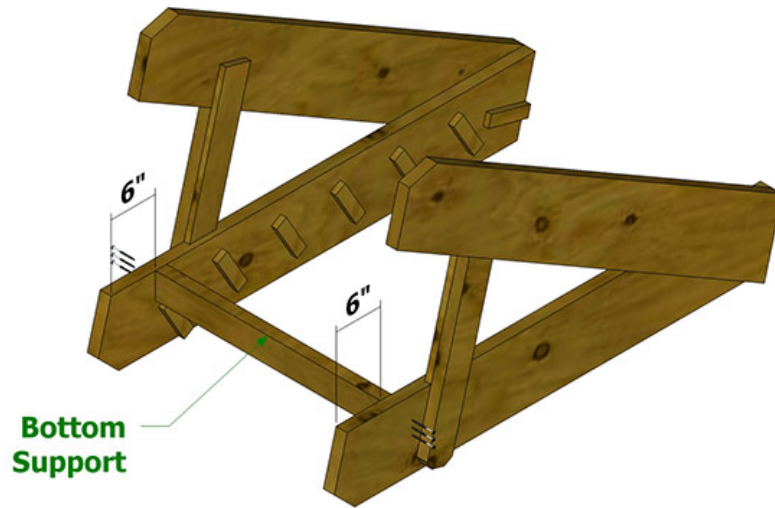

Figure 13

Position the **Bottom Support** as shown in **Figure 13** and attach using 2 1/2-inch deck screws.

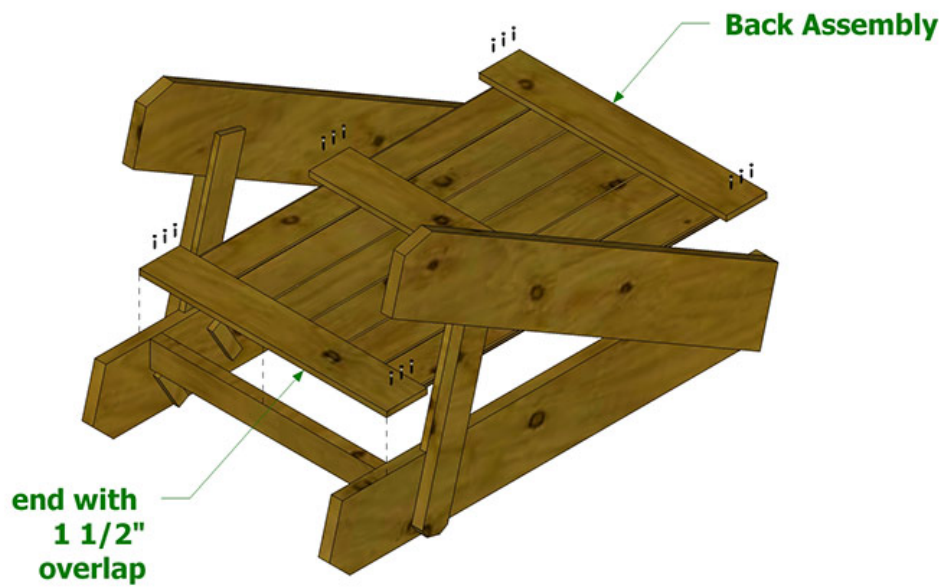

Figure 14

Position the **Back Assembly** with the **Back Support** that extends 1 1/2 inches beyond the end of the **Back Slats** flush against the bottom edge of the **Bottom Support** as shown in **Figure 14** and attach using either 1 1/4-inch deck screws or 2 1/2-inch deck screws.



Figure 15

Position the **Top Shelf** as shown in **Figure 15** and attach to the top **Cleats** using 1 1/4-inch deck screws.

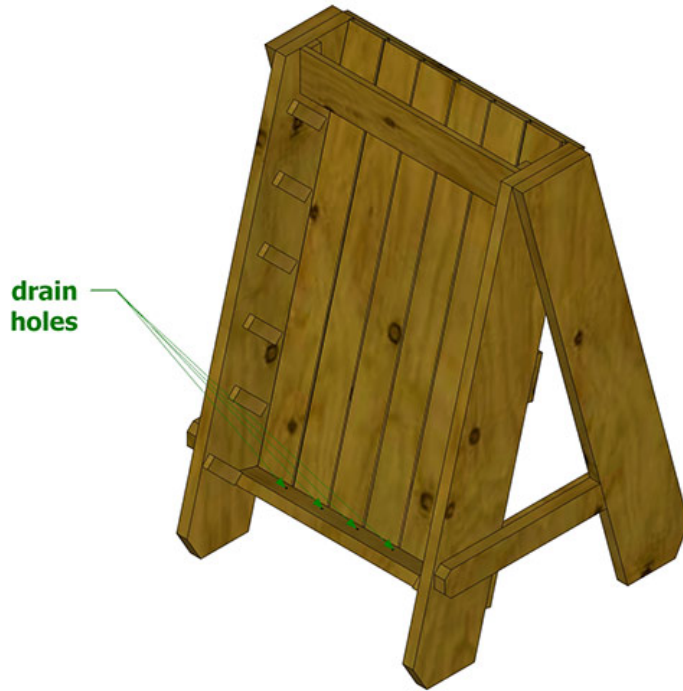

Figure 16

Drill drain holes (at least 1/4-inch) in the **Bottom Support**, roughly in line with the joints of the **Back Slats** as shown in **Figure 16**.



Figure 17

Insert the **Shelves** resting on the **Cleats** as shown in **Figure 17**. (Do not attach them to the **Cleats**.) The grooves located at the joints of the **Back Slats** act as drainage channels for each segment.

Finished Dimensions:

Height: 55 1/2 inches

Width: 36 1/2 inches

Depth: 37 1/2 inches