

LE-200 PROFINET IO

[Click Here](#) for a Quote - customer@tr-electronic.com

Order-#: 2200-00802

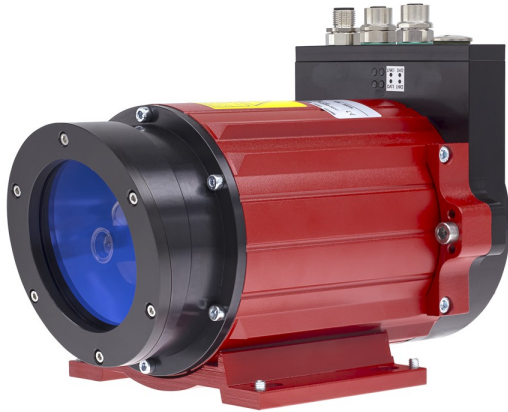

Stock photo

Advantages

- Customer-specific solutions
- Flexible programming
- Further interfaces available
- Measures linear movements
- Measuring dista. 125/170/195n
- Rugged construction
- Wear-free detection



Technical data for 2200-00802

RESOLUTION	1,0
MEASURING RANGE	125M
INTERFACE	PROFINET IO
CODE	PROGRAMMABLE
SUPPLY VOLTAGE	18-27V
CONNECTOR TYPE	2X4P+8P MALE/4P FEMALE/M12
CONNECTOR-POSITION	RADIAL
TEMPERATURE RANGE	0-50°C
PROTECTION Class	IP65
LASER PROTECTION CLASS	2
OPTIONS ENC	FULL STROKE LINEARIZED PROGRAMMABLE
REFLECTIVE-FOIL	YES
WATER COOLING	NO
PINOUT NO.	TR-ELE-TI-DGB-0020
DRAWING NO.	04-K2200-017
DOCUMENTATION NO	DOKUMENTE

Subject to change.

LE-200 PROFINET IO LINEARISIERT

Order-#: 2200-00802

14.5.2020 / 010203020002040199

General data for K-LE200-PN-1

Characteristics - Validity	Min. operation time > 30 min
Supply	
- Supply voltage	18...27 VDC \pm 5%
Current consumption no load	\leq 450 mA
Integrated heating	
- Equipment	Option
- Nominal voltage	24 VDC \pm 5 %
- Nominal power	48 W
Measuring principle	Phase shift measurement
Measuring length	
- Measuring against	Reflector foil
- Standard measuring range	0.2...125 m
- Range extension 1	170 m
- Range extension 2	195 m
Resolution	0.1 mm physically
Linearity deviation	\pm 3 mm \leq 12 m, absolute \pm 5 mm FS, absolute
- FS:	Full-Scale
Reproducibility	\pm 2 mm
Light source	
- Laser diode	Red light
- Wave length λ	670 nm
- Laser protection class	2
- International safety standard	IEC 60825-1
- American safety standard	FDA 21CFR 1040.10 / 1040.11
- American safety standard	observe "Laser-Notice No. 50"
- Radiant power P	\leq 1 mW
Measurand output/refresh rate	1000 Values/s
Integration time	1 ms
PROFINET IO - Interface	
- PROFINET IO – Device	IEC 61158, IEC 61784-1
- Physical Layer	Fast Ethernet, ISO/IEC 8802-3
- PROFINET-Specification	V2.2
- Conformance Class	B, C
- Real-Time-Classes	Class 1, 2 (RT), Class 3 (IRT)
SSI - Interface	
- Equipment	Standard interface
- Equipment	supported as from July 2016
- SSI-Clock input	Optocoupler

Subject to change.

LE-200 PROFINET IO LINEARISIERT

Order-#: 2200-00802

14.5.2020 / 010203020002040199

General data for K-LE200-PN-1 continuation

- SSI-Data output	RS-422, 2-wire
- SSI-Clock frequency	80...820 kHz
- SSI-Mono time, typically	20 µs
Transmission rate	
- Specific value	10 MBit/s
- Specific value	100 MBit/s
Cycle time	>= 1000 µs (IRT/RT)
Parameter/Function, changeable	Addressing
	Resolution
	Error outputs
	Intensity parameter
	Preset parameter
	Adjustment - Parameter
	SSI-Parameter
	Temperature parameter
	Counting direction
	Velocity parameter
Type of parametrization	programmable
Programming - Tool	Fieldbus-Device
	TR-Soft: TRWinProg
External inputs	
- Function input	Preset adjustment
- Function input	Switch-off of the laser diode
- Function input	Error acknowledgement
- Type of parametrization	programmable
- Logic level, LOW	"0" < +2 V, <= ±35 V, 5 kOhm
- Logic level, HIGH	"1" > +8 V
- Number of inputs	1
External outputs	
- Status output	Temperature
- Status output	Intensity
- Status output	Hardware
- Status output	Speed
- Status output	Position
- Logic level, LOW	"0" < 1 V, <= 100 mA
- Logic level, HIGH	"1" > Supply Voltage – 2 V
- Type of parametrization	programmable
- Number of outputs	1

Subject to change.

LE-200 PROFINET IO LINEARISIERT

Order-#: 2200-00802

14.5.2020 / 010203020002040199

Environmental data

Vibration	
- Specific value	$\leq 50 \text{ m/s}^2$
- Sine	50...2000 Hz
Shock	
- Specific value	$\leq 300 \text{ m/s}^2$
- Half sine	11 ms
Immunity to disturbance	DIN EN 61000-6-2
Transient emissions	DIN EN 61000-6-3
Working temperature	
- Standard	0...+50 °C
- Optional	-30...+50 °C;
Storage temperature, dry	-20...+75 °C
Temperature drift	1 ppm/°C $\leq 125 \text{ m}$
	1 ppm/°C $\leq 170 \text{ m}$
	1 ppm/°C $\leq 195 \text{ m}$
Relative humidity	98 %, non condensing
Protection class	
- Standard	IP65

Subject to change.

4pol. M12-Buchse
D-kodiert

8pol. M12-Stecker
A-kodiert

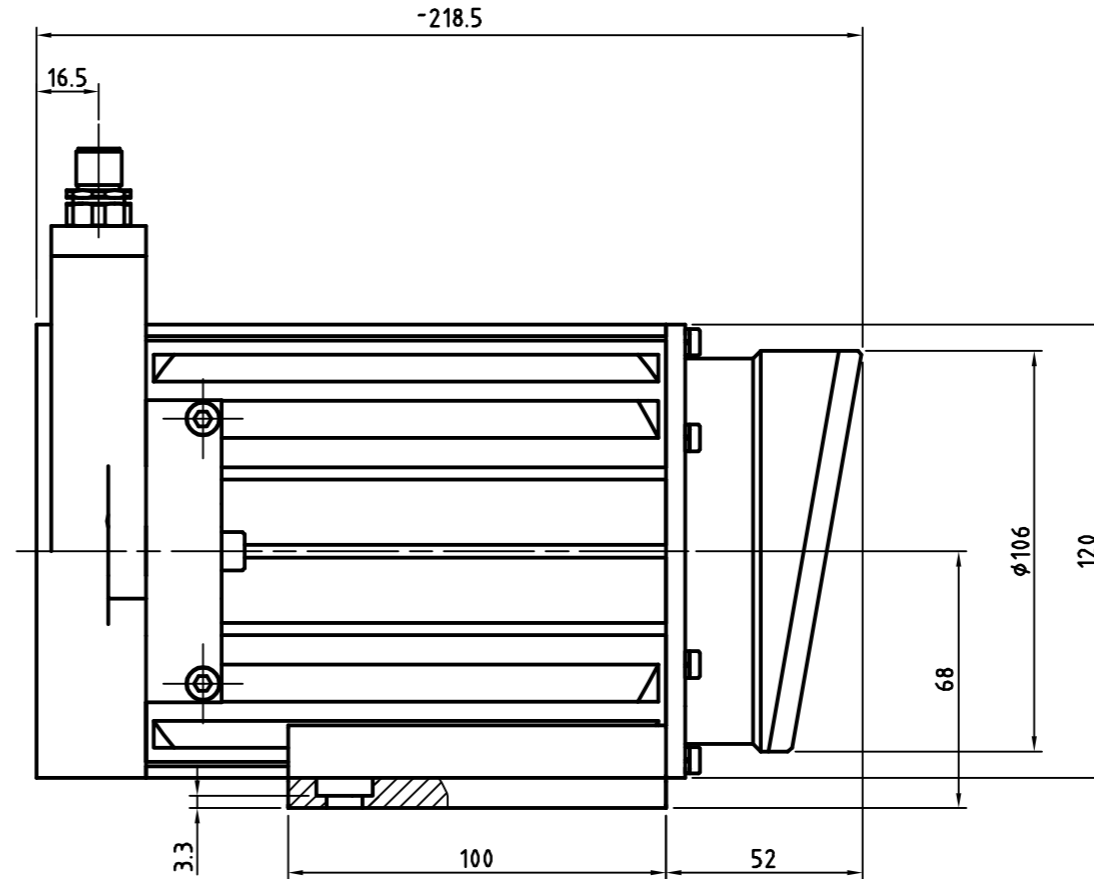
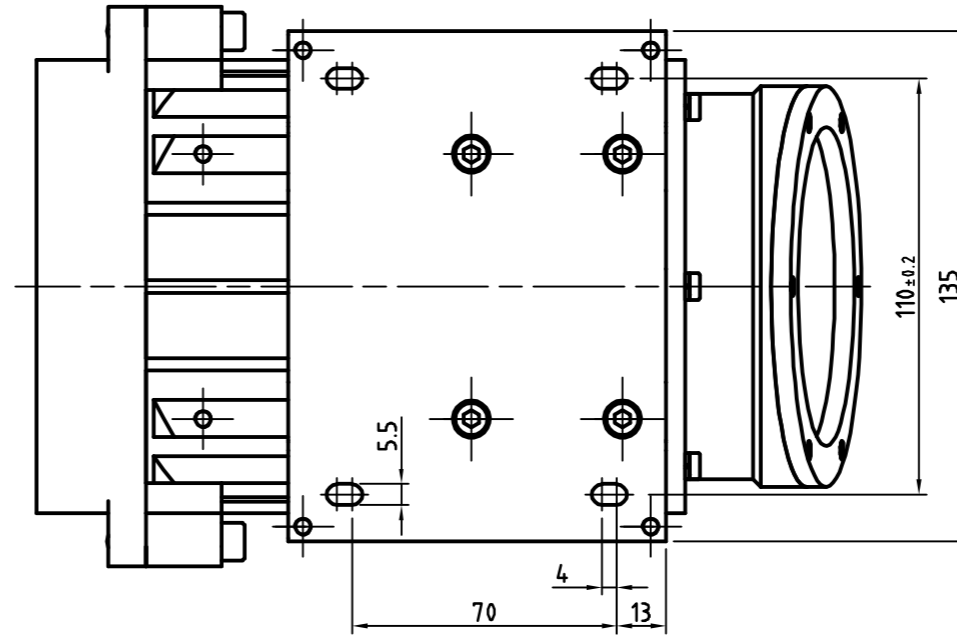
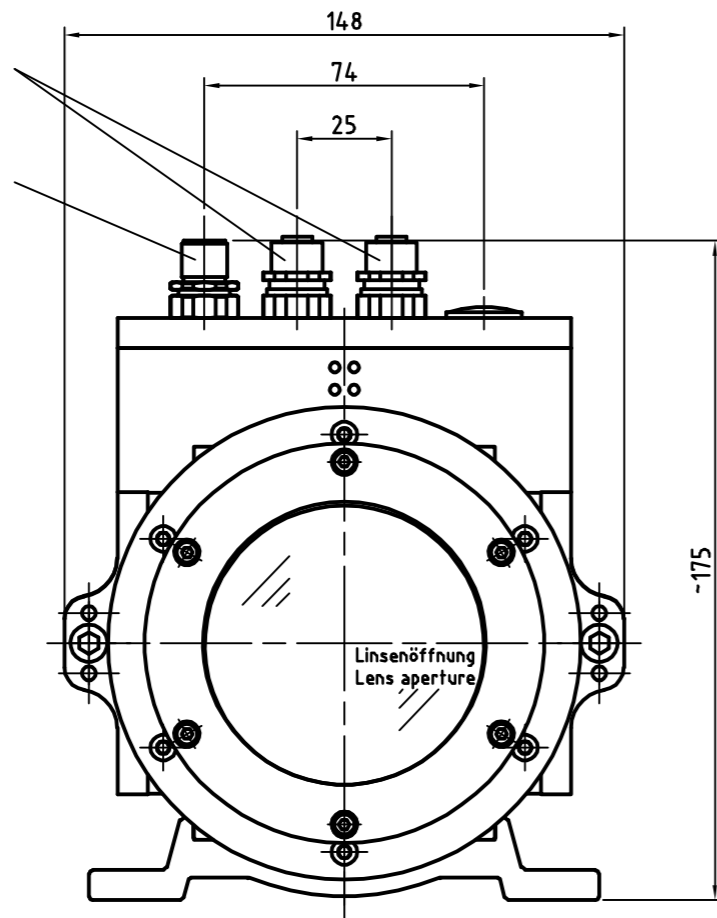

Artikel-Nr. und Steckerbelegung: siehe Datenblatt
Article-No. and pin connections: see data sheet

 TR Electronic GmbH Eglisshalde 6 78647 Trossingen Telefon 07425/228-0	Maßstab 1:2 DIN A3 Projekt-Nr.:			
	Zeichnungs-Nr. nur für diese Ausführung gültig Drawing-No. only for this type valid			
Datum Name		LE-200		
Erstellt	19.06.2012 STIER			
Bearb.	19.06.2012 STIER			
Gepr.				
Norm		Zeichnungs-NR../Drawing-No.: 04-K2200-017		
www.tr-electronic.de DXF+Info: info@tr-electronic.de				
Zust.	Änderung	Datum	Name	Blatt 1 B1

Steckerbelegung / Pin Assignment

Steckerbelegung für Laser LE-200 mit PROFINET + SSI Schnittstelle / Pin Assignment for laser LE-200 with PROFINET + SSI Interface

Der Schirm ist großflächig auf das Gegensteckergehäuse aufzulegen!
The shielding is to be connected with large surface on the mating connector housing!

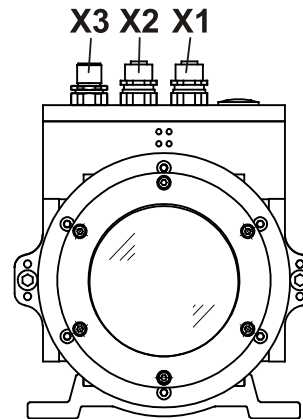

X1		PORT 1; Flanschdose / Female socket (M12x1-4 pol. D-coded)		
1	TxD+	Sendedaten +	Transmission Data +	
2	RxD+	Empfangsdaten +	Receive Data +	
3	TxD-	Sendedaten -	Transmission Data -	
4	RxD-	Empfangsdaten -	Receive Data -	

X2		PORT 2; Flanschdose / Female socket (M12x1-4 pol. D-coded)		
1	TxD+	Sendedaten +	Transmission Data +	
2	RxD+	Empfangsdaten +	Receive Data +	
3	TxD-	Sendedaten -	Transmission Data -	
4	RxD-	Empfangsdaten -	Receive Data -	



X3		Flanschstecker / Male socket (M12x1-8 pol. A-coded)		
1	18 – 27 V DC / 24 V DC; Supply voltage Standard / Heizung (Heating)			
2	GND, 0V; Versorgung / Supply voltage			
3	TRWinProg + oder/or Daten + / Data +			
4	TRWinProg - oder/or Daten - / Data -			
5	Switching Input; High: > +8 V, Low: < +2 V			
6	Switching Output; High: > US-2 V, Low: < 1 V			
7	Takt + / Clock +	Bei Takt einspeisung, ist die SSI-Schnittstelle aktiv / At clock input, SSI interface is enabled		
8	Takt - / Clock -			

Steckerbelegung / Pin Assignment

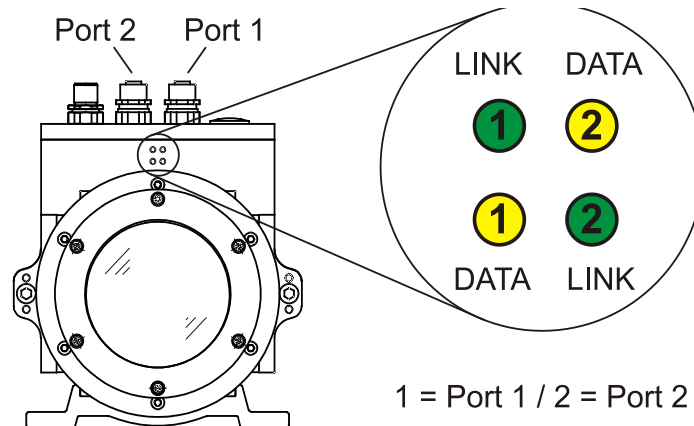

Diagnose-LEDs / *Diagnosis-LEDs* (2 x LED grün / *green* / 2 x LED gelb / *yellow*)



Link-LEDs (grün / *green*)

	Physikalische Verbindung vorhanden / <i>Physical connection available</i>
	Keine physikalische Verbindung vorhanden / <i>No physical connection available</i>

Data-LEDs (gelb / *yellow*)

	Kein Datenaustausch / <i>No data transfer</i>
 oder 	Datenaustausch / <i>data transfer</i>

Blinkmodus durch Projektier-Tool / *Flashing mode due to development tool*

	2 Hz, grüne LEDs <i>2 Hz, green LEDs</i>
---	---

Bestellangaben zum Ethernet Steckverbinder, passend zur Flanschdose M12x1-4 pol. D-kodiert /
Order numbers for the Ethernet connector, suitably for the D-coded female socket M12x1-4 pol.

Hersteller / <i>Manufacturer</i>	Bezeichnung / <i>Name</i>	Art-No.:
Binder	Series 825	99-3729-810-04
Phoenix Contact	SACC-M12MSD-4CON-PG 7-SH (PG 7)	15 21 25 8
Phoenix Contact	SACC-M12MSD-4CON-PG 9-SH (PG 9)	15 21 26 1
Harting	HARAX [®] M12-L	21 03 281 1405