

HPC – HIGH PERFORMANCE COUNTING

B22 Double Head Counting Machine



Features

The Task

- The market demands widely customizable double-head counting machine in different configurations.
- The focus is on easy adaptation of the versions to the customer's processes and needs.

The Solution

- Our new Köster HPC B22 universal double head counting machine.
- Widely customizable.
- Compatible with all counting discs from our range.

The Advantages

- High efficiency - Increased productivity through simple operation
- High accuracy - 99%
- High flexibility - Range from 35 - 500 g/m²
- High durability - Solid, high quality construction
- High cost effectiveness - Low maintenance costs

The Flexibility

- All types of substrates used in the global security printing industry can be processed with the highest speed and accuracy.

The Substrates

- Cotton based products
- Coated products
- Hybrid products
- Laminated products
- And much more

The Standard Machine

- Left counting head:
 - Fixed.
 - Corner counting position.
- Right counting head:
 - Movable.
 - Electrically adjustable to format size.
 - Laser sensor controlled detection of the positioning if the ream length is exceeded.
 - Large and strong alignment stops at the counting heads.
 - Additional alignment stops between and next to the counting heads can be mounted.
- Ready to use C “corner counting” or S “edge counting” discs:
 - Both heads can be independently equipped with “C” or “S” discs.
- Airflow machine table:
 - Hard anodized aluminium.
 - Microperforated.
- Plug & Play commissioning.
- To the machine frame integrated printer location.
- Standard voltage supply Single-phase 230V-AC / 50-60Hz .

The Operation

- Counting direction from top to bottom
- Best ergonomics for the operator
- Large working height adjustment range 790 – 1100 mm
- Precise and fast product handling
- No adapters required
- Solid alignment stops at the counting heads
- User-friendly HMI interface with single-sided user interface

The Machine Design

- All installed components are high-quality products from global manufacturers.
- The machine design ensures easy maintenance and low upkeep costs as well as maximum machine availability.
- Machine’s high performance and availability results from the robust and precise construction out of steel and aluminium.

The Equipment

Wide range of integrated features in the standard version:

- **Security Counting:**
Results are compared with the pre-set value, if they do not match, the product is not automatically released.
- **Batching:**
A pre-selected number of sheets can be easily batched to form a layer. The counting disc is used for separation to provide a gap for the operator to easily separate the layers.
- **Firmware or Program Update:**
Firmware or program version updates are easily carried out using an USB memory stick.

The Options

- Single head version
- Tab inserter
- Min. format length 210 mm without tab inserter
- Min. format length 250 mm with left-sided tab inserter
- Retractable lateral alignment rods
- Lateral stamping unit
- Integrated compressor
- Casters
- Printer kit
- Warranty extension 24 months except wear parts

The Double Head Versions

➤ Standard Version:

- ✓ Right counting head movable.
- ✓ The movable counting head is motor-driven to the desired position according to the programme settings.

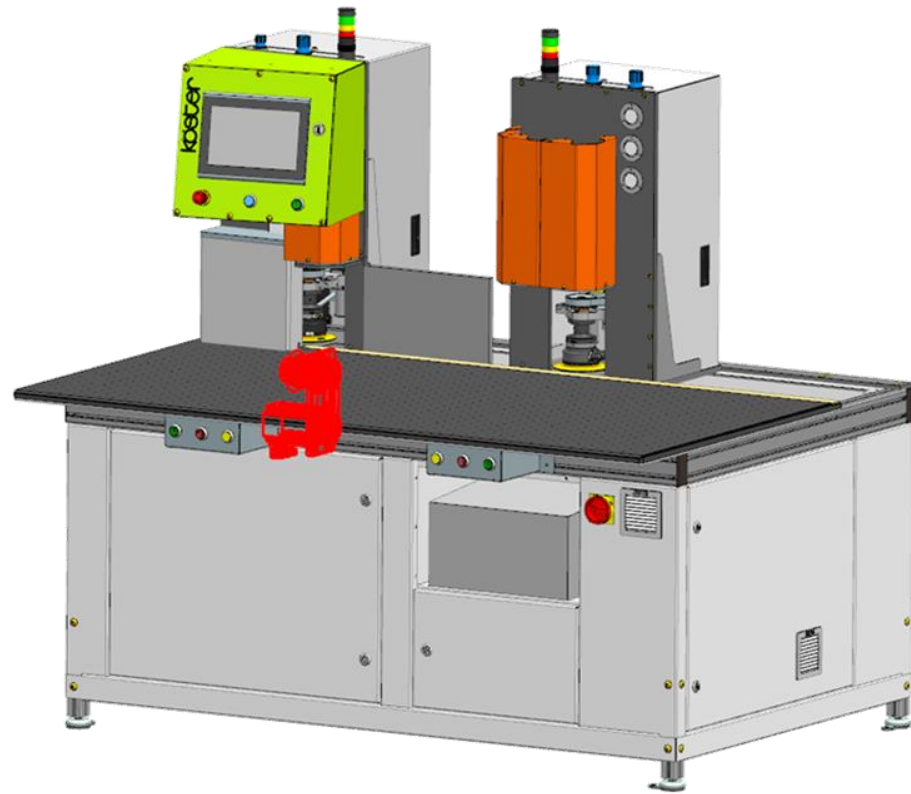

The Double Head Versions

➤ Version 1 - Option RMH1:

- ✓ Left counting head fixed, right counting head movable.
- ✓ The movable counting head is positioned manually using the handwheel.
- ✓ Mechanical millimetre display for position control on the handwheel.

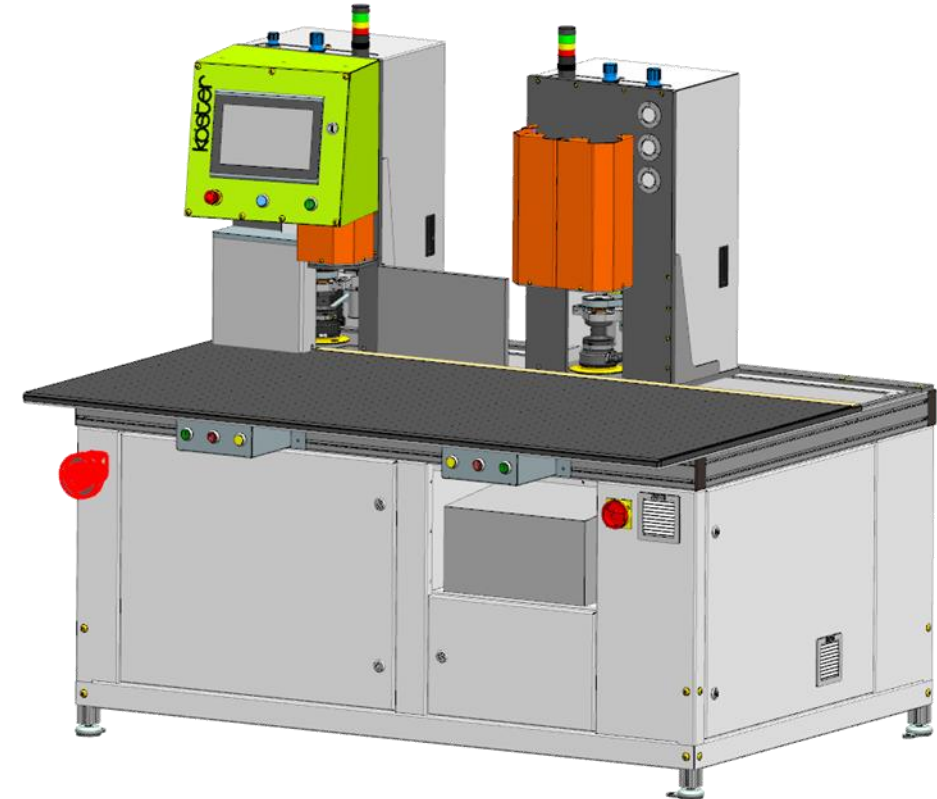

The Double Head Versions

➤ Version 2 – Option RMH2:

- ✓ Left counting head movable, right counting head movable.
- ✓ Both counting heads are motor-driven to the desired positions according to the programme settings.

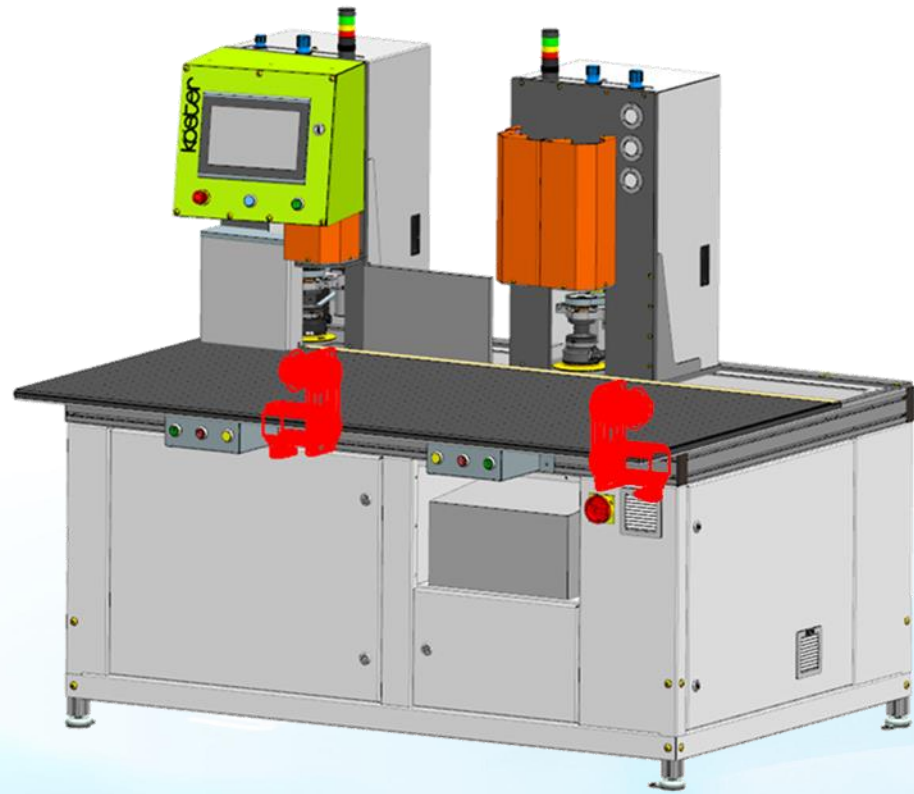

The Single Head Version

➤ Standard Version - Option B22-10:

- ✓ One left-hand counting head.
- ✓ Counting head fixed not movable.

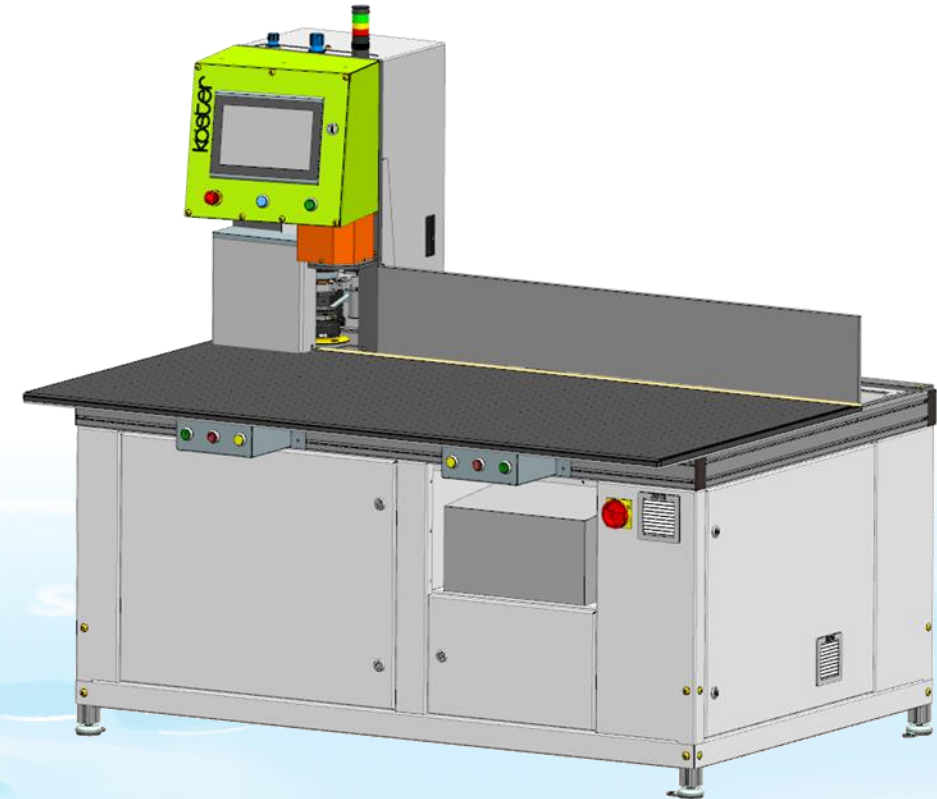

The Uniqueness

- Standard max. counting speed, highest available in the market:
 - ✓ 2000 RPM / min. (6 segments discs = 12.000 sheets / min.).
 - ✓ Compatible with 3,4 and 6 segments discs.
- GSM range 35 g/m² - 500 g/m², widest GSM range available in the market:
 - ✓ Discs for wide substrates range available.
- State-of-the-art drives:
 - ✓ Speed independent torque availability.
 - ✓ No jamming of the disc at low revolutions during batching or counting.
 - ✓ Precise stopping.
 - ✓ No overcounting, eliminate the risk of overcounting when the pre-set value is acquired.
- Depending on substrate counting heads can be parallel equipped with S-discs:
 - ✓ Edge and corner counting position with one disc type.
- Capsuled counting heads:
 - ✓ User-friendly reduction of noise pollution.
 - ✓ The press-plates are integrated into the counting heads shells.
- Fully integrated User Access Management:
 - ✓ User access according to different user levels.
- Unrivaled precision:
 - ✓ Mono block steel base to assure machine rigidity.
- Integrated printer location:
 - ✓ Space for a printer integrated in the machine frame for protocol printouts.

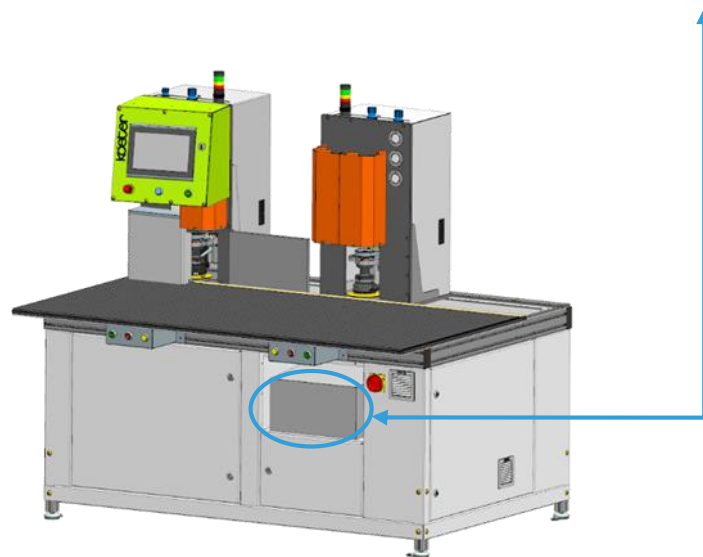

During counting the disc is capsuled for noise protection

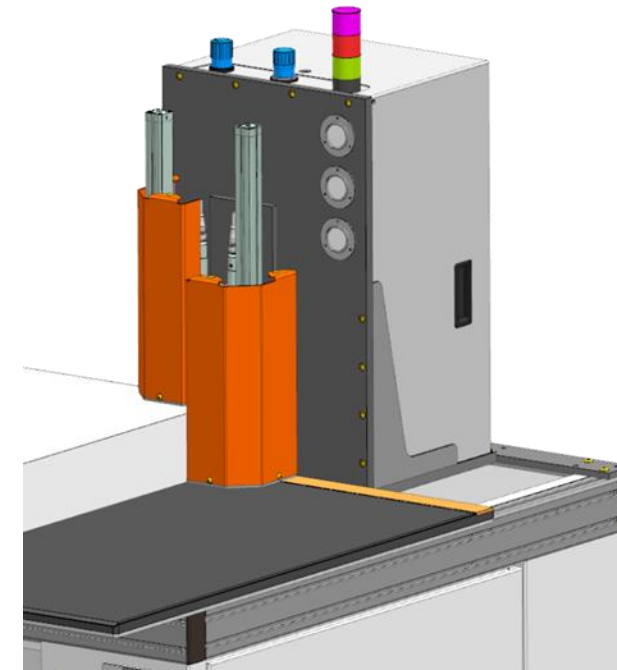

Additional alignment stops can be mounted

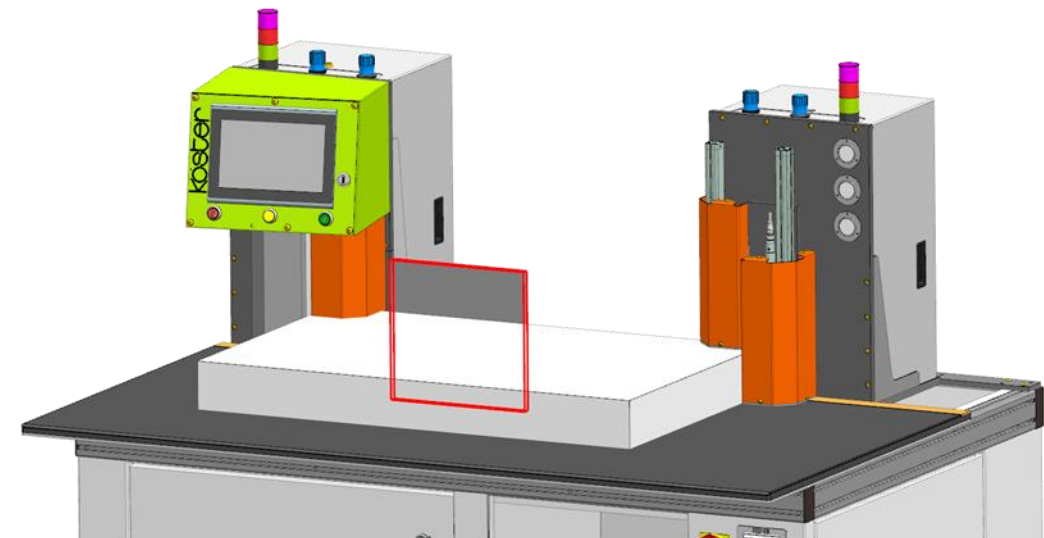

Features

Counting head weight adjustable via pressure reducer

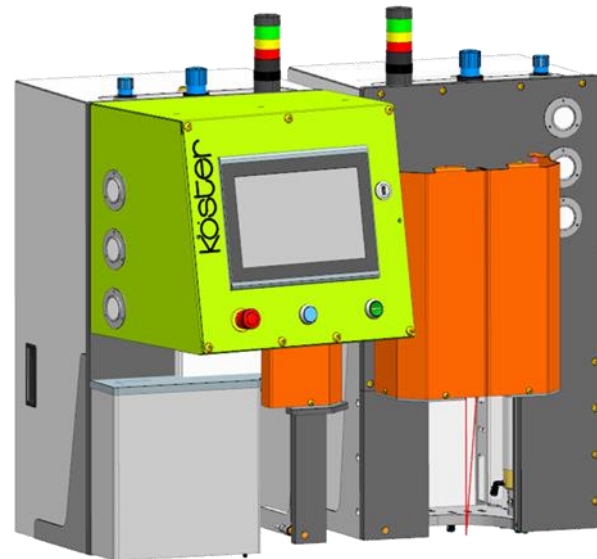

Press plate force adjustable via pressure reducer

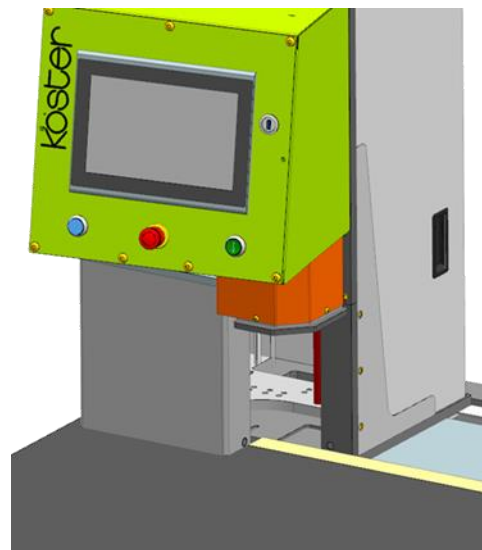

Technical Specifications

Dimensions	L	W	H			
Overall (mm):	1680	1270	1644 - 1931			
Table (mm):	1680	900				
Weight						
Machine weight (kg):	400 - 500					
Working Height						
Working height (mm):	790 - 1100					
Supplies						
Electric:	Single-phase 230V-AC / 50-60Hz / max. back-up fuse 16A / full load current 15A					
Pneumatic:	Min. 6 bar / oil and water-free / consumption 400 l/h					
Format Sizes						
Min. layer height (mm):	1					
Max. layer height (mm):	200					
Tab Inserter (optional)						
Minimum sheets between inserting (pcs.):	1					
Possible configuration:	One per head, left head, right head or both heads.					
Corner Counting						
			One tab inserter		Two tab inserters	
	L	W	L	W	L	W
Min. format size (mm):	295	80	295	80	295	80
Max. format size (mm):	1100	900	1100	900	1100	900
Edge Counting						
			One tab inserter		Two tab inserters	
	L	W	L	W	L	W
Min. format size (mm):*	295	80	300	80	350	80
Max. format size (mm):	1680	900	1680	900	1680	900
*Depending on the substrate						

Technical Specifications

Counting Technology						
Counting method:	Disc					
Counting direction:	Top to Bottom					
Counting Discs	Min.	Max.	Type	Position	Equipped	Tab Inserter
GSM (g/m ²):	40	200	S6	Edge	Optional	Available
GSM (g/m ²):	70	270	S9	Edge	Optional	Available
GSM (g/m ²):	35	150	C2	Corner	Default	Available
GSM (g/m ²):	50	200	C6	Corner	Optional	Available
GSM (g/m ²):	250	500	C4	Corner	Optional	Available
Counting discs to process higher GSM values available upon request. Depending on the stiffness and quality of the products, these values may deviate during processing.						
Counting Speed	RPM	Type	Segments	Sheets/Min.	Sheets/Sec.	
Rated RPM:	2.000	S6	4	8.000	133	
Rated RPM:	2.000	S9	4	8.000	133	
Rated RPM:	2.000	C2	6	12.000	200	
Rated RPM:	2.000	C6	6	12.000	200	
Rated RPM:	2.000	C4	3	6.000	100	
Depending on the stiffness and quality of the products, these values may deviate during processing.						

Impressions

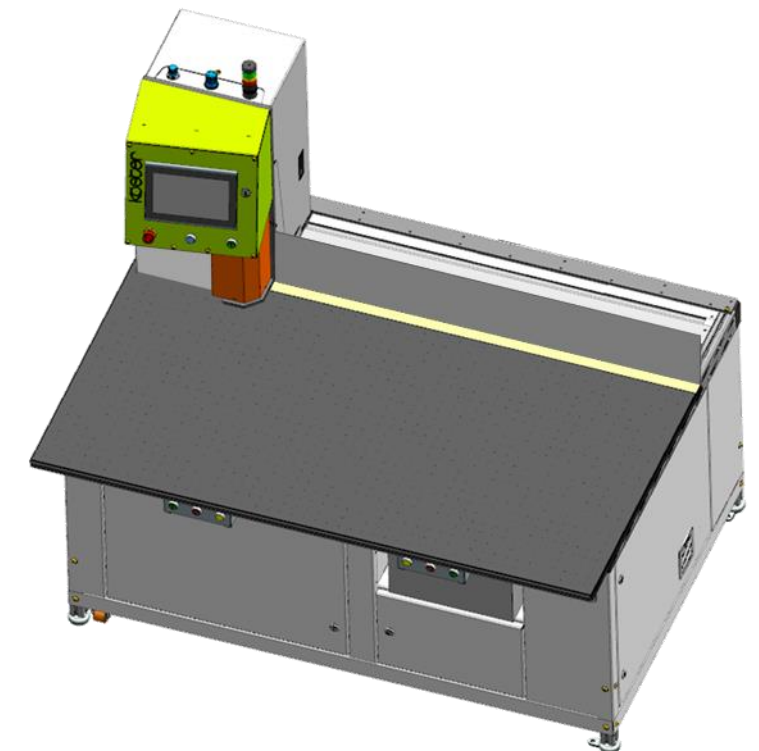
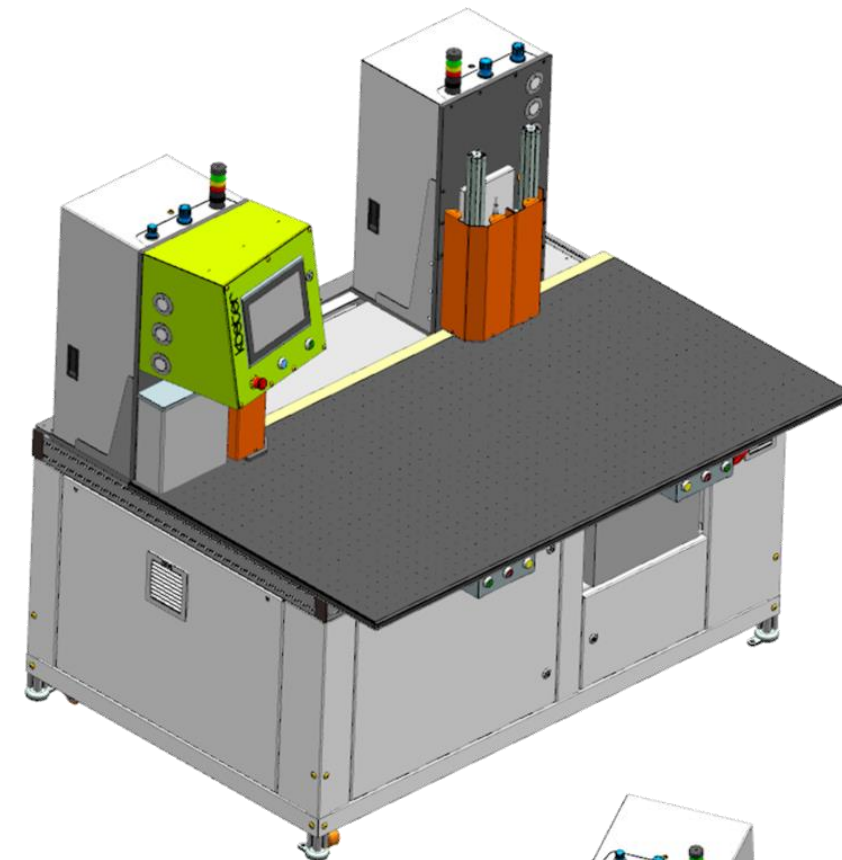

Impressions

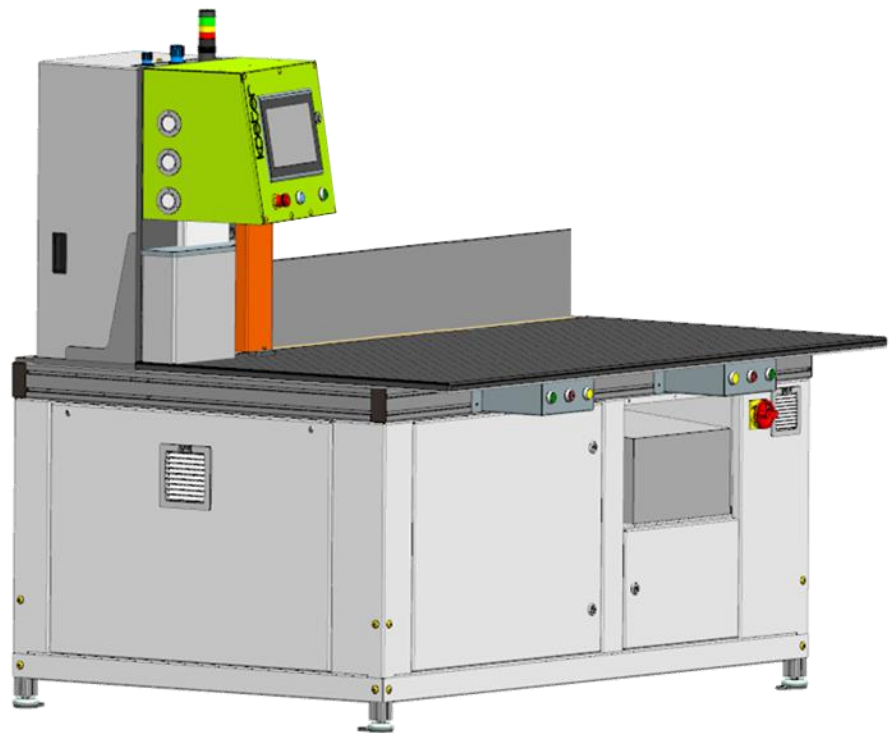

Technical Specifications

Processable Substrates

Currency Industry:	Currency and documents paper, coated or uncoated, polymers, hybrids and much more.
Consumer Industry:	Consumer paper, coated or uncoated, laminated, plastics, polymers and much more.

PLC Control

Brand:	B&R
Touchscreen:	10,1" colored multilingual, main HMI with pictograms
Interfaces:	FTP (Client / Server)/USB/MQTT (TCP / IP)/OPC UA/Profinet/Profibus/Ethernet-IP/ Device Net / CAN-Bus / CAN-Open / EtherCat / X2X Link Powerlink / Modbus TCP /

Operating Noise

Max. dB(A) at 2000 RPM:	78	
Environmental Conditions	Min.	Max.
Recommended temperature range (+°C):	15	35
Recommended relative humidity range (%):	35	45

Certification

CE Certificate:	Complies with all applicable European standards.
-----------------	--

B22

Machine Layout

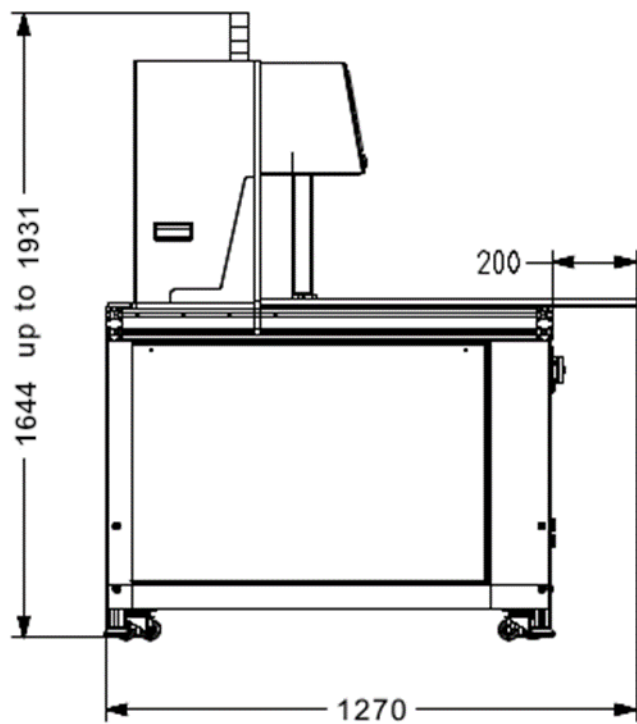

B22

Impressions

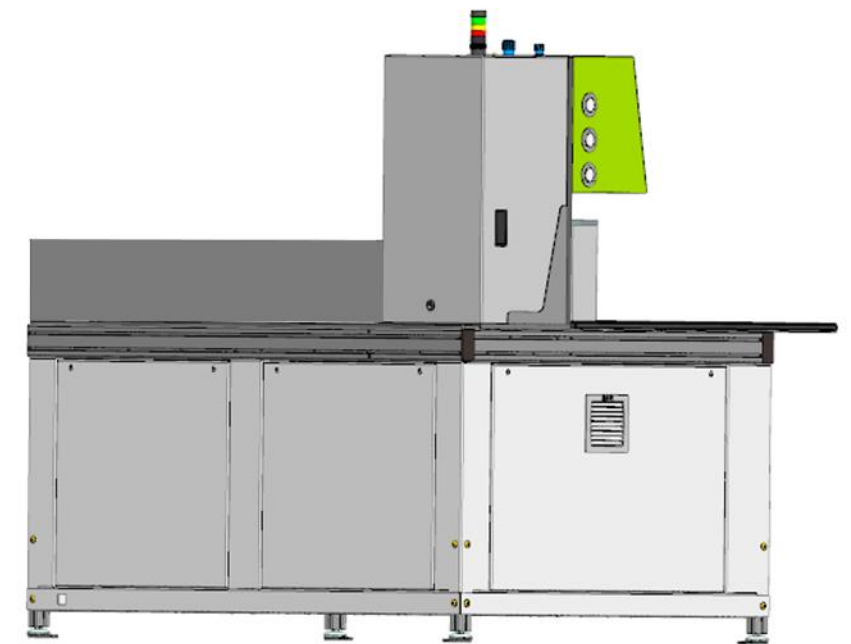
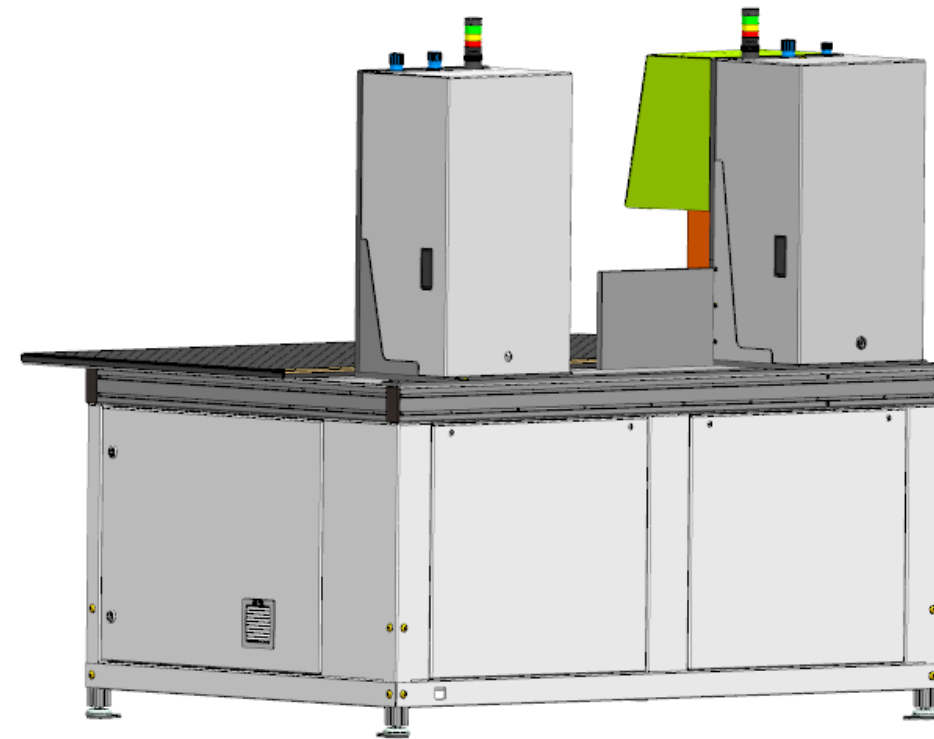

Machine Layout

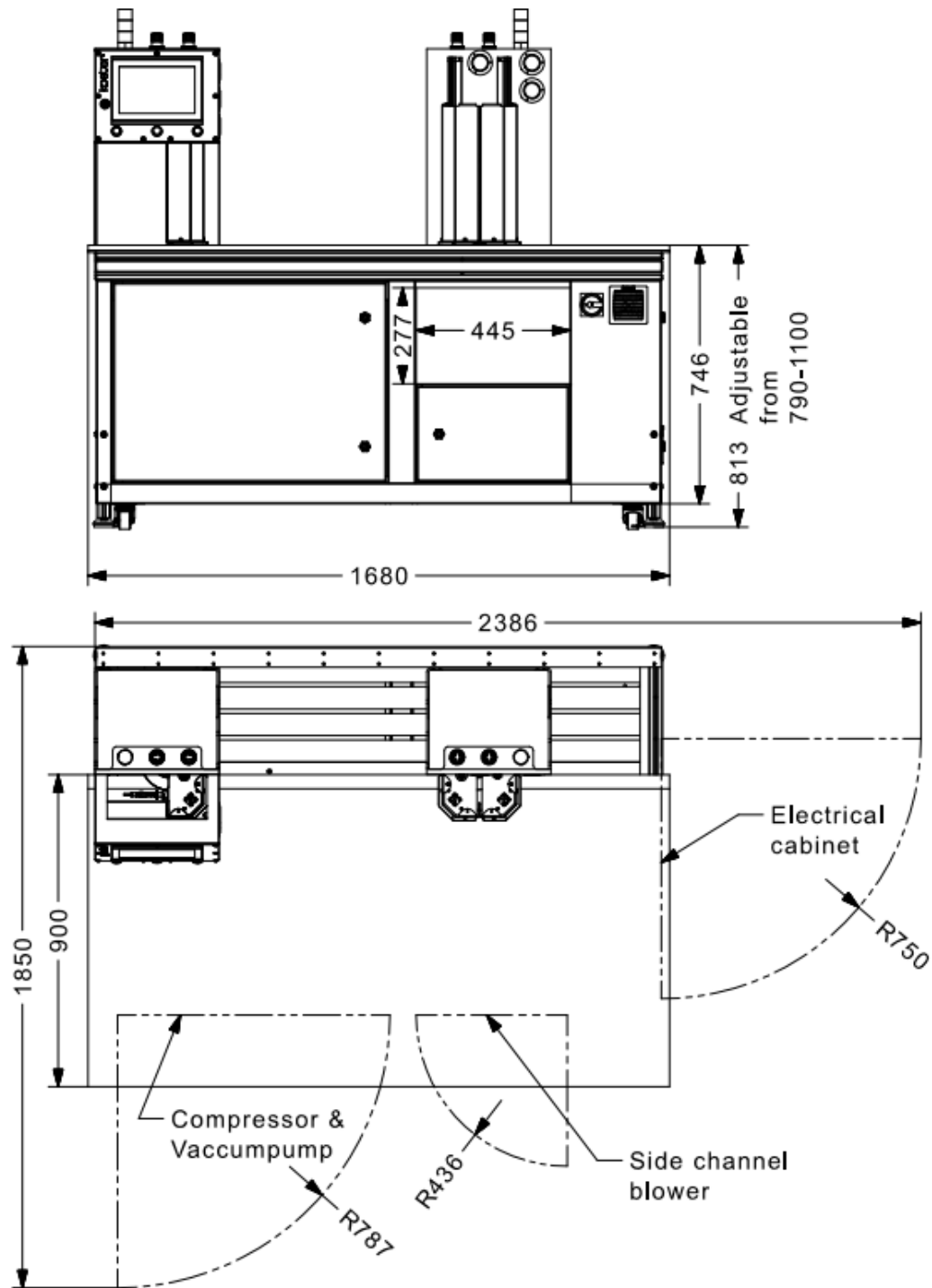

Machine Layout

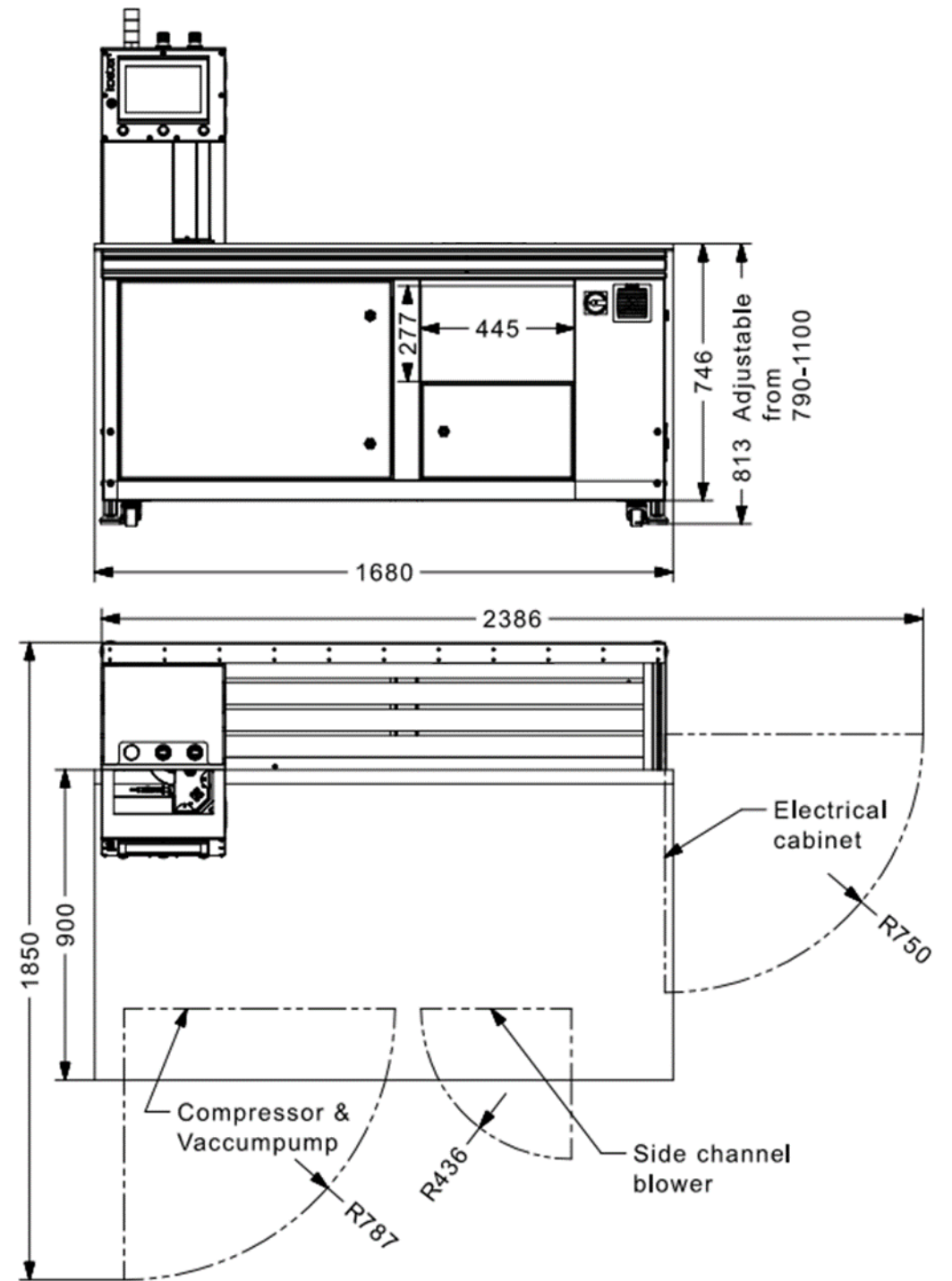

Counting Discs – Since 1991



HPC – HIGH PERFORMANCE COUNTING

Basic Information

Counting Discs:

- The details of the GSM values are based on experience and tests. Depending on the product rigidity, these values may differ.
- Older produced counting discs for corner position are designated by 1xx,x for the diameter in "mm" and / or "V8 - V15" depending on the type.
- Newly produced counting discs for corner position are designated by "C1-Cx" depending on the type.
- Newly produced counting discs for edge position are designated by "S1-Sx" depending on the type.
- Warranty for the lifetime of the counting discs is not granted as the abrasive wear depends highly to the processed product.

Counting Machines:

- Maximum counting speed refers generally to the rated maximum rpm value and the machine design.
- It is not granted that maximum speed can be attended using all kind of substrates / materials.
- Warranty time 12 months upon issuing of the acceptance certificate.
- Warranty extension 24 months optionally available.
- Warranty coverage except wear parts.

koester
Maschinen- und Werkzeugbau

**Made in Germany –
Made for the world**