

GOZONE

HOME FITNESS | REMISE EN FORME À DOMICILE

DOOR GYM / BARRE DE TRACTION EN SUPINATION



**ASSEMBLY STEP /
ÉTAPES DE L'ASSEMBLAGE**

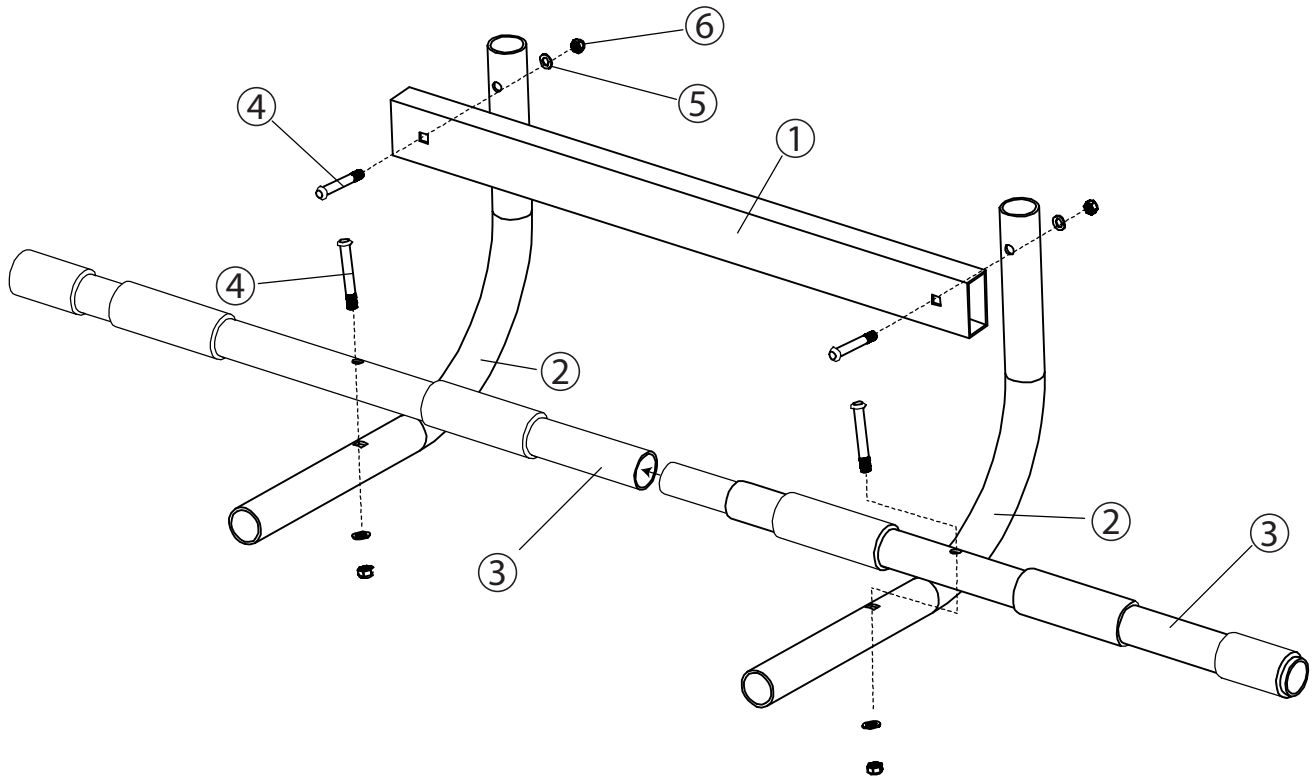

PART LIST / LISTE DES PIÈCES

NO.	DESCRIPTION	Q'TY
1.	Cross Tube / Tube Transversal	1
2.	Up Tube / Tube Supérieur	2
3.	Handle Tube / Tube De Poignée	2
4.	M6x50 Bolt / Boulon M6*50	4
5.	M6 Washer / Rondelle M6	4
6.	M6 Nylon Nut / Écrou En Nylon M6	4