

Cool Energy **inverTech** Monoblock Series
Heat Pump Water Heaters

Version 6.6



Installation and Users Guide

**IMPORTANT SAFETY INSTRUCTIONS
READ AND FOLLOW ALL INSTRUCTIONS**

RETAIN FOR FUTURE REFERENCE

Customer Service and Technical Support

(Open from 9am-4pm Monday- Friday)

Phone: 01472 867497

Email: sales@coolenergyshop.com

Address: Office & Showroom - 163 Cleethorpe Road, Grimsby, DN31 3AX

Website: www.coolenergyshop.com



Table of Contents

IMPORTANT SAFETY PRECAUTIONS.....	3
Health and Safety	3, 4
Important End User Safety Information.....	4
Section 1.....	5
Introduction.....	5
Product Overview.....	5
General Features.....	5
Section 2.....	6
Installation.....	6
Materials needed for installation.....	7
Installation of Outdoor Unit.....	7, 8
Suggested Installation Methods.....	9, 10, 11, 12, 13
Water Connections.....	14
Plumbing Installation Requirements.....	14
Electrical Connections.....	15
General Information.....	15
Electrical Wiring Diagram.....	16, 17
Power Supply.....	18
Grounding and Over Current Protection.....	18
Section 3.....	19
Operating Heat Pump.....	19
LCD User-Friendly Interface Controller.....	19
General Instruction.....	19
Controller Panel.....	19
Operating Controller	19
1. Keys / Icons Explanation.....	19
2. System Status Display Value.....	19
3. On/ Off Setting.....	20
4. Mode Setting.....	20
5. Time / Clock Setting.....	21
6. Engineer Settings.....	22,23
7. Input / Output Readings.....	24
8. Weather Compensation.....	25,26
General Operating Guide.....	27
User Guide.....	28
Product Protection.....	28,29,30,31,32
Section 4.....	33
Commisioning.....	33
Service & Maintenance.....	33
Inspection and Service.....	33
Owner Inspection.....	34
Section 5.....	35
Benchmark.....	35
Commissioning Checklist.....	35
Service Record.....	36

HEALTH AND SAFETY INFORMATION

INFORMATION FOR INSTALLER AND SERVICE ENGINEERS

Under the Consumer Protection Act 1987 and the Health and Safety at Work Act 1974, it is required to provide information on substances hazardous to health (COSHH Regulations 1998).

Cool Energy takes every reasonable care to ensure that these products are designed and constructed to meet these general safety requirements, provided they are properly installed and used.

To fulfil this requirement, products are comprehensively tested and examined before dispatch.

When working on the appliance, it is the responsibility of the user/engineer to ensure that any necessary personal protective clothing or equipment is worn when appropriate for parts, which could be considered hazardous or harmful.

This appliance may contain some of the items below:

Refrigerants

The appliance contains R410a refrigerant. The constituents of R410a are R134a, R32 and R125 all of which have low toxicity levels.

When handling, avoid inhalation and contact with the skin and eyes. Suitable personal protective equipment (PPE) must be worn (gloves, overalls, eye protection) and a comprehensive first aid kit (containing eyewash) should be easily available.

Site engineers should have a certificate of competence and should know and understand the properties and hazards before handling liquid refrigerants.

When the appliance has come to the end of its life span, an approved engineer must dispose of the equipment and refrigerants in accordance with the EU laws.

Seek urgent medical attention if inhaled or digested. Exposure to eyes and skin should be followed by immediate cleansing of the affected areas and medical attention if necessary.

Insulation

Fibre insulation may be irritating to the skin, eyes, nose and throat. When handling, avoid inhalation and contact with the eyes. Use disposable gloves, facemasks and eye protection.

After handling, wash hands and other exposed parts. When disposing, reduce dust with water spray and ensure all parts are securely wrapped.

Glue, Sealants and Paints

Glue, sealants and paints are used in this appliance and present no known hazards when used in the manner of which they are intended.

Oils

The compressor contains FV50S oil within the refrigeration system. The compressor itself is hermetically sealed, and this cannot be repaired.

Manual Handling

Air Source Heat Pumps are by nature bulky and heavy items. Please pay attention to the weight of the unit before attempting to move it. It may be necessary to use lifting aids to ensure safe manual handling to avoid injury.

The weight of the heat pumps can be found on data sheets, packaging and product data badges.



Transport of Heat Pump

When transporting your heat pump its important to keep it upright. The refrigeration system inside contains oil, gas and liquids which can be disturbed when moving your heat pump. If at any stage during transporting your unit it is inclined more than a 45° angle, its important to leave the unit upright for at least 4 hours to allow the refrigeration system to stabilise again before use.



IMPORTANT SAFETY INFORMATION FOR THE END-USER

- Installation of the appliance must only be carried out by persons with suitable competence.
- Do not attempt to modify, repair or service the appliance yourself.
- Do not insert body parts or any other items into the air inlet or outlet.
- Do not start or stop the unit by removing the power cable; always use the controls and switches provided.
- If installed outside, ensure the appliance is protected from prolonged exposure to large quantities of water.
- Do not operate the unit or the programmer with wet fingers.
- Keep the programmer unit out of reach of children.
- The electrical supply must be isolated during a heightened risk of lightning strikes.
- Do not attempt to move the appliance once it is installed; this must be carried out by a qualified engineer.
- Isolate the electrical supply to the appliance if an odour presents, or scorching is detected.
- Only use this appliance for the purpose intended.
- Ensure the area around the appliance is clean, well-ventilated and kept free of all obstructions.
- Do not keep items on top of the appliance or use it to support other appliances.
- Do not under any circumstances stand on the appliance.
- Isolate the electrical supply to the appliance if it is to be switched off for a period of more than two months.
- Periodically check the condition of any supports for deterioration.
- Do not wash the unit with water, alcohol, benzene, thinner, glass cleaner or powders.
- During cleaning, isolate the electrical supply to the appliance.

Section 1

Introduction

Product Overview

Air Source Heat Pumps transfer heat from the ambient air to water, providing high-temperature hot water up to 60°C. The unique Cool Energy inverTech heat hump is widely used for house heating or hot water.

With our innovative & advanced technology, the pro mono block range of heat pumps can operate very well down to -20°C ambient temperature with high output temperatures up to 60°C. Compared with traditional Oil / LPG boilers, Cool Energy heat pumps produces up to 50% less CO² whilst saves up to 80% on running costs. Cool Energy heat pumps are not only highly efficient, but also easy and safe to operate.

General Features

1. Low running costs and high efficiency.
 - A high coefficient of performance (COP) of up to 5, results in lower running costs compared with traditional ASHP technology.
 - No immersion heater supplement is required.
2. Reduced Capital Costs.
 - Simple installation
 - Compatible with traditional radiator systems, under floor heating or fan coils.
3. High Comfort Levels.
 - High storage temperature results in increased hot water availability.
4. No potential danger of any inflammable, gas poisoning, explosion, fire, electrical shock which are associated with other heating systems.
5. A digital controller is incorporated to maintain the desired water temperature.
6. Long-life and corrosion resistant composite cabinet stands up to severe climates.
7. The latest compressor technology ensures outstanding performance, ultra-energy efficiency, durability and quiet operation.
8. Self-diagnostic control panel monitors and troubleshoots heat pump operations to ensure safe and reliable operations.
9. Intelligent digital controller with friendly user interface and blue LED back light.
10. Separate isolated electrical compartment prevents internal corrosion and extends heat pump life.
11. The heat pump can operate down to ambient air temperature of -20°C.

Section 2

Installation

The following general information describes how to install the air source heat pump.

Note: Before installing this product, read and follow all warning notices and instructions. Only a qualified / competent person should install the heat pump.

Materials needed for Installation:

The following items are needed and are to be supplied by the installer for **all** heat pump installations:

1. Plumbing fittings.
2. Level surface with provision for condensate drainage.
3. Suitable anti-vibration feet.
4. Ensure that a suitable electrical supply cable is provided. See the rating plate on the heat pump for electrical specifications. Please take a note of the specific current rating. No junction box is needed at the heat pump; Connections are made inside of the heat pump electrical compartment. Conduit may be attached directly to the heat pump casing.
5. It is advised to use PVC conduit for the electrical supply cables.
6. Ensure correctly sized pipe work to obtain minimum water flow rates required.
7. Flexible hoses are recommended for connection between heat pump and rigid pipework.
8. A filter on the water inlet to the heat pump is required.
9. The plumbing should be insulated to reduce heat losses, and water treated with a suitable inhibited antifreeze.

Note: We recommend installing shut-off valves on the inlet and outlet water connections for ease of serviceability.

Note: For detailed specifications of the units please refer to name plate on the units. Correct installation is required to ensure safe operation. The requirements for Cool Energy heat pumps include the following:

1. Appropriate site location and clearances.
2. Wiring to conform to 18th edition wiring regulations.
3. Adequate water flow. (See Page 31.)

This manual provides the information needed to meet these requirements. Review all application and installation procedures completely before continuing the installation.

Installation of Outdoor Unit

The heat pump should be installed on a solid level base that can take the weight, preferably a concrete foundation. If concrete slabs are used, they must rest on asphalt or shingle.



The heat pump should not be positioned next to sensitive walls, for example, next to a bedroom. Also ensure that the placement does not inconvenience the neighbours. The heat pumps must not be placed so that recirculation of the outdoor air can occur; this causes lower output and impaired efficiency.

Large amounts of condensation water as well as melted waters from defrosting can be produced. Condensation water must be led off to a drain, soakaway or similar.

The outdoor unit should be installed in a ventilated place, with enough space for air inlet and outlet, while without thermal radiation or other heat source. The air outlet should not be against the wind.

Generally, horizontal air flow type heat pump does not generally need sheltering. The structure design has protected all internal components against rain and sunshine. A shelter is necessary to avoid snow burying the heat pump in heavy snow areas.

Please make sure the standardized voltage 220V-240V is available to the heat pump, otherwise the performance would be influenced and could affect your warranty.

The foundation of the heat pump can be a cement or steel structure. Anti-vibration rubber feet and a flat foundation are generally required. The foundation structure can be flexibly designed according to the working weight of the heat pump. (Please see the technical data in this manual.)

Water drainage should be available near the installation location for draining water in an effective way. Do not install the heat pump in a place where there is polluting or corrosive materials like oil, flammable and explosive gas and sulphide ect. Keep it far away from sands, falling leaves and area with high-frequency equipment.

Installation on a balcony or on a roof-top must be in accordance with the allowable stress of the building structure.

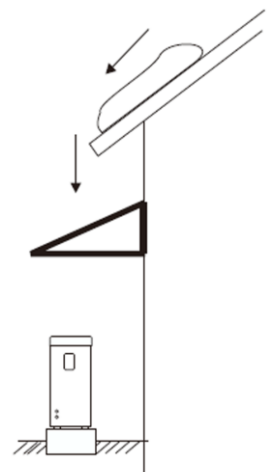

The installation space should be referred as follows:

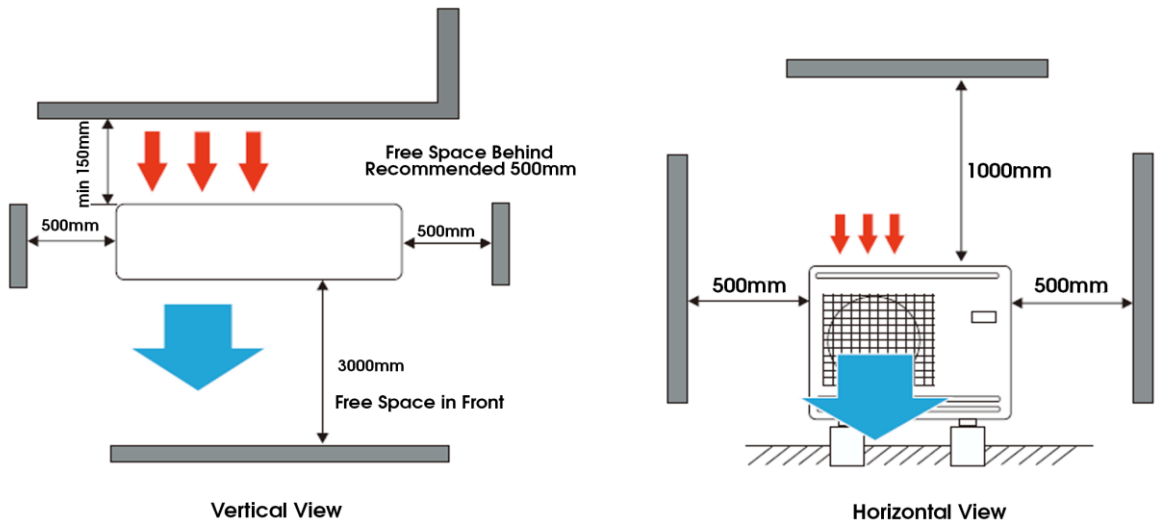

Intake and outlet should not be obstructed. The wall the unit is to be mounted on should be strong enough to bear the weight and vibrations of the unit.

Allow for proper clearances around the unit. Location should allow easy access for maintenance.

For any further guidance on heat pump installations for planning purposes, please consult the latest version of the MCS guidelines or your local authority.

Example Installation Method 1: - Heating only with radiators

Pro/inverTec Range - Heating Only Example Diagram

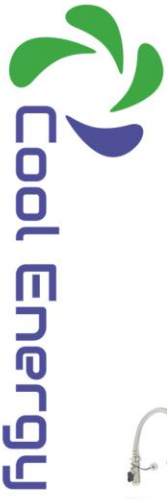
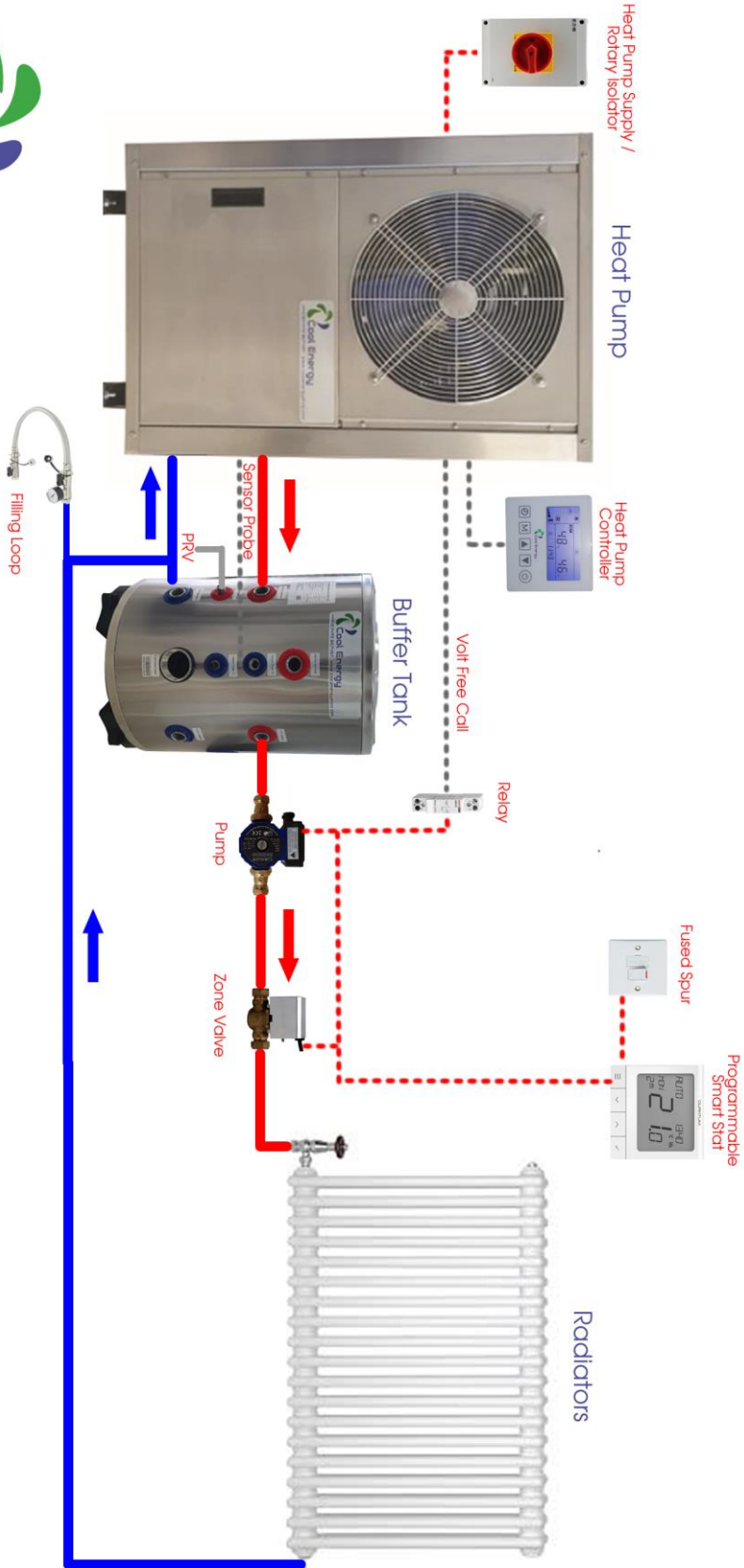

www.coolenergyshop.com

Radiators Only

Example Installation Method 2: - Heating only with radiators

Pro/inverTec Range - Heating Only Example Diagram

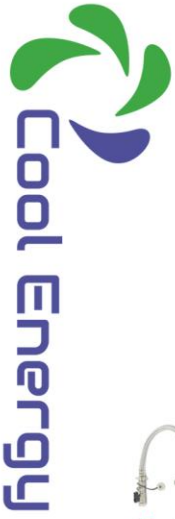
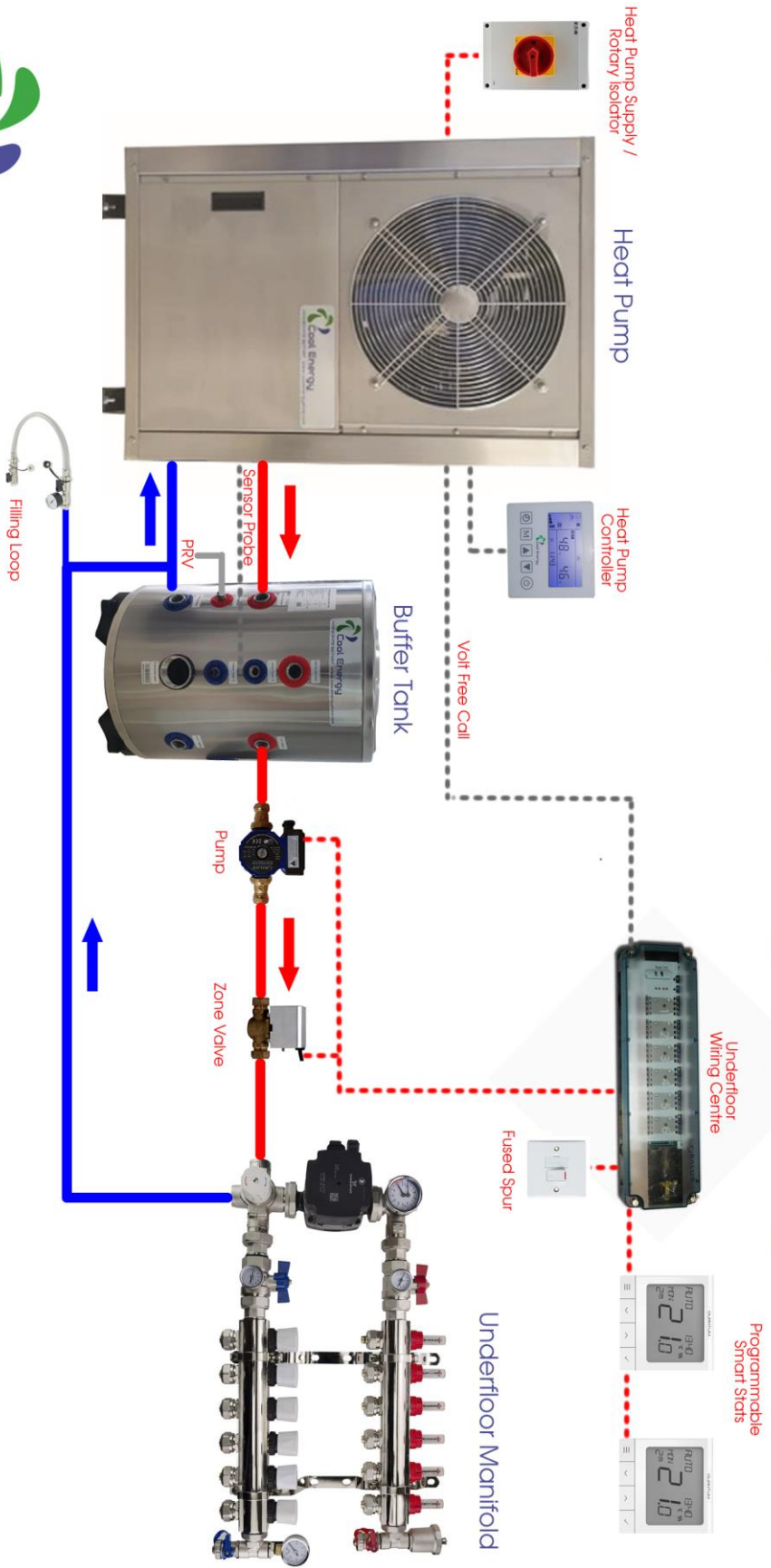

www.coolenergyshop.com

Underfloor Only

Example Installation Method 3: - Heating Only with Underfloor & Radiators

Pro/inverTec Range - Heating Only Example Diagram

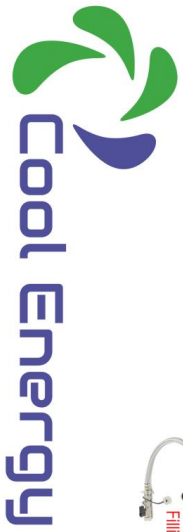
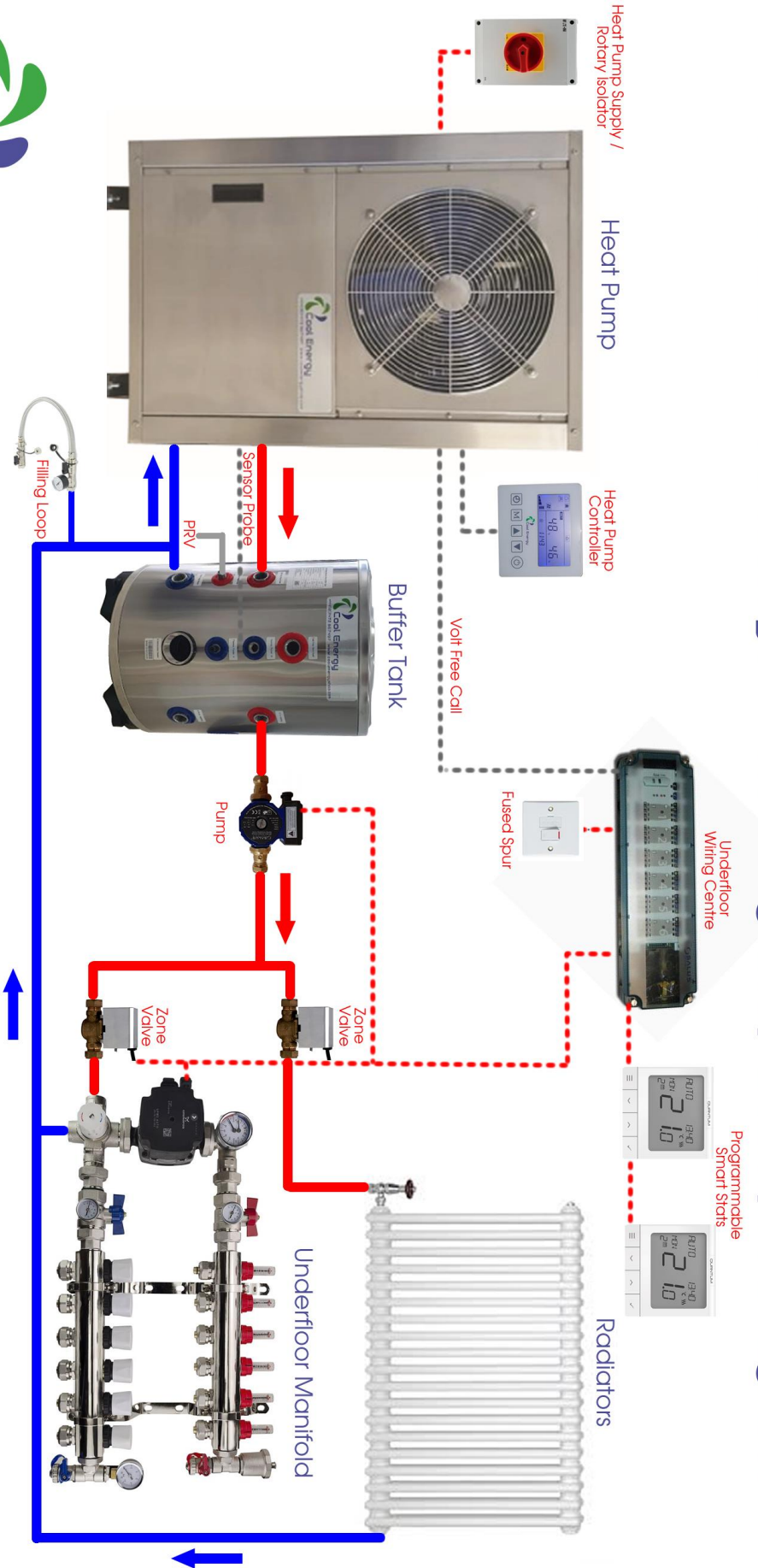

www.coolenergyshop.com

Radiators & Underfloor

Example Installation Method 4: - Hot Water / Thermal Store Only

Pro/inverTec Range Hot Water Only Example Diagram

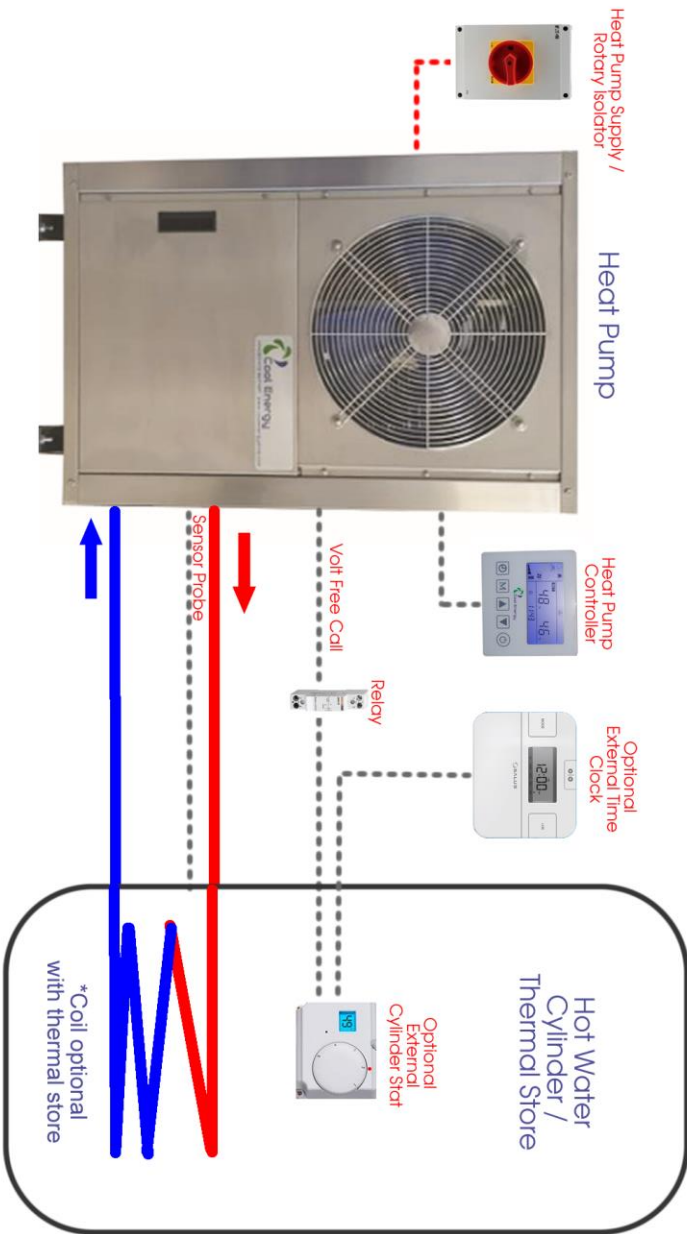

www.coolenergyshop.com

Cylinder / Thermal Store

Example Installation Method 5: - Hot Water & Heating

inverTec Range - Hot Water & Heating Example Diagram

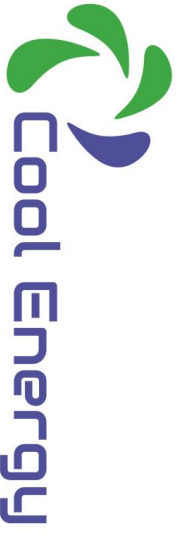
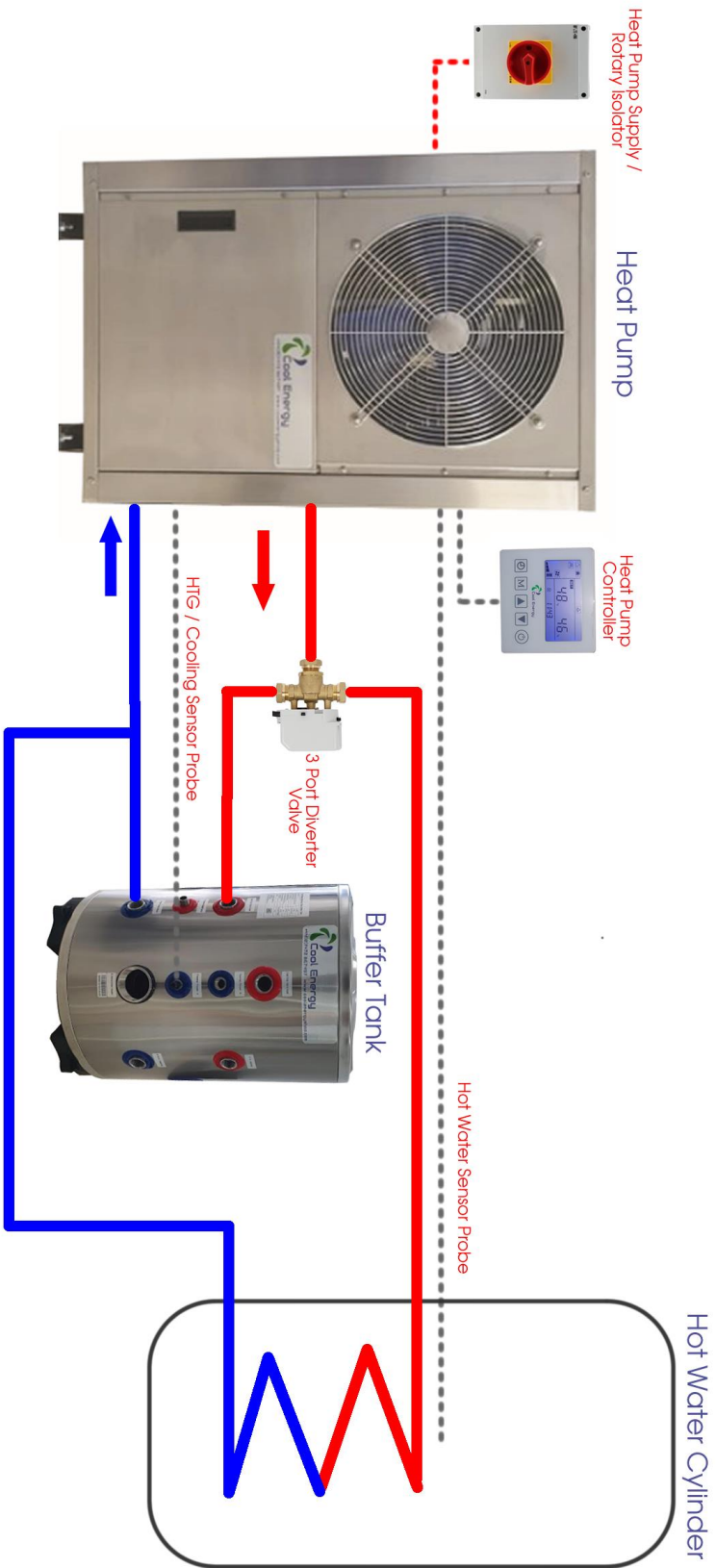

www.coolenergyshop.com

Hot Water & Heating

Water Connections

Water connections at the heat pump

Flexible pipe fittings are recommended to be installed on the flow and return connections.



The water inlet and outlet connections to the heat pump, accept standard BSP threaded fittings.



CAUTION – Make sure that the required water flow rates can be maintained at all times.

Plumbing Installation Requirements

1. Water pressure should not exceed 3 Bar.
2. Each part connected to the unit needs to be connected with method of loose jointing and installed with intermediate valves.
3. Ensure that all plumbing has been properly flushed and tested. (See Page 31.)
4. All pipelines and pipe fittings must be insulated to prevent heat losses.
5. Install a drain valve at the lowest point of the system to enable the system to be drained fully.
6. Install a check valve on the water outlet connection if back siphoning could occur.
7. In order to reduce the back pressure, the pipes should be installed horizontally.
8. Minimum flow rates detailed on the data badge must be maintained and could void warranty and damage unit if they are not.

Electrical Connections

 **WARNING** – Risk of electrical shock or electrocution.

Ensure that all high voltage circuits are disconnected before commencing heat pump installation. Contact with these circuits could result in death or serious injury to users, installers or others.

 **CAUTION** – Label all wires prior to disconnection when servicing the heat pump. Wiring errors can cause improper and dangerous operation. Check and ensure proper operation after servicing.

General Information

Wiring connections must be done according to the wiring diagram found on the inside of the heat pump access panel or see addendum A for reference.

The heat pumps must also be earthed. A ground lug is provided on the inside of the heat pump electrical compartment.

The supplied controller is pre-wired using a low voltage low loss cable and can be easily moved and located where required.

The controller plugs directly onto the cable supplied with no additional wiring required.

If you wish to extend this cable or any of the sensor cables, please use a shielded low loss cable.

Circuit Breaker Sizing:

CE-iVT9	–	20a Type C MCB / RCBO
CE-iVT18	–	32a Type C MCB / RCBO
CE-iVT18 3PH	–	16a Type C MCB / RCBO
CE-iVT26 3PH	–	20a Type C MCB / RCBO
CE-iVT32 3PH	–	32a Type C MCB / RCBO

3 Phase inverTech Models:

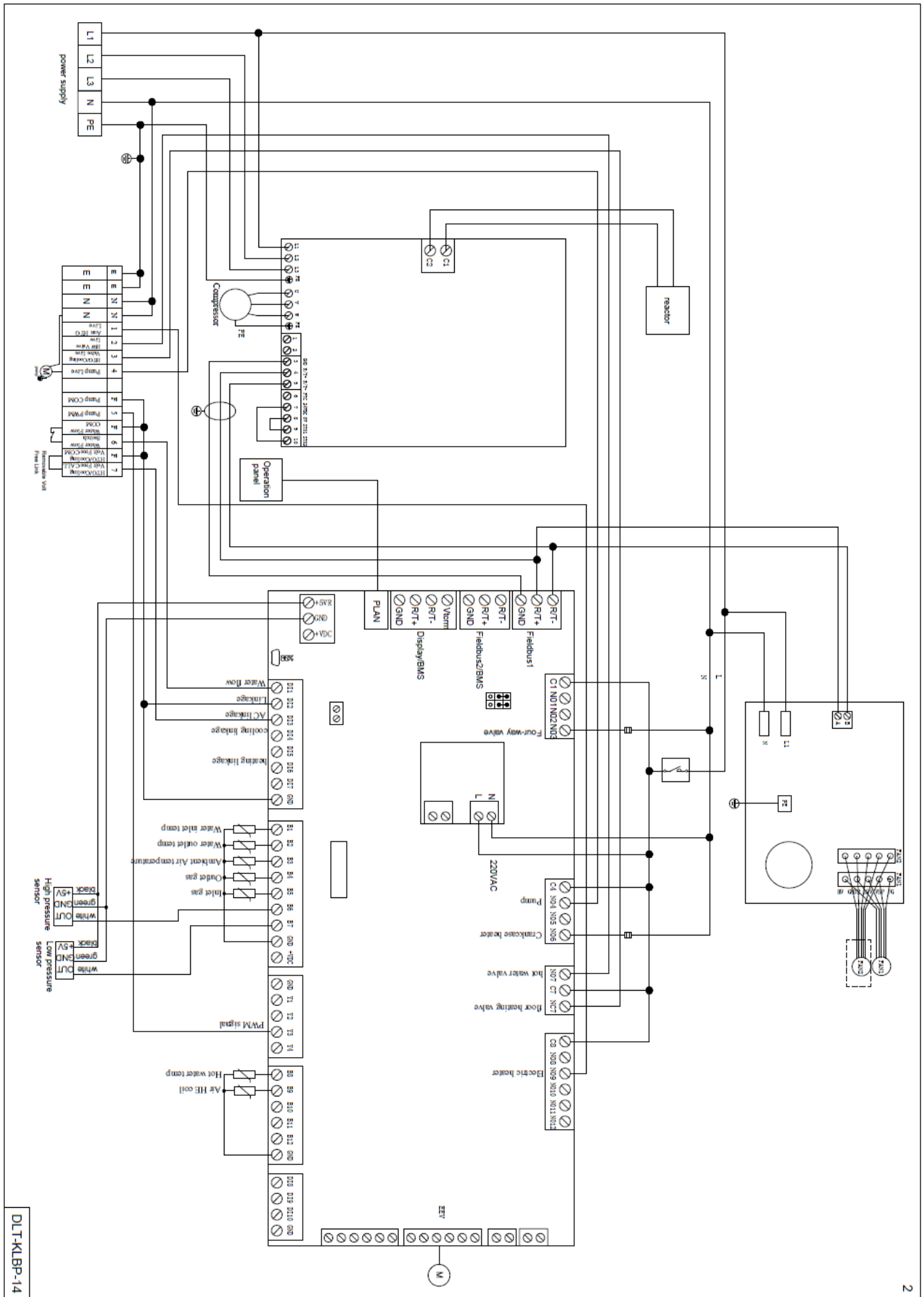

Power Supply

1. If the supply voltage is too low or too high, it can cause damage and/or result in unstable operation of the heat pump unit, due to high inrush currents on start up.
2. The minimum starting voltage should be above 90% of rated voltage. The acceptable operating voltage range should be within $\pm 10\%$ of the rated voltage. When heat pump units are installed in parallel, ensure that the voltage difference, between these units, is within $\pm 2\%$ of each other. The voltage difference between phases of a three-phase power supply should be within $\pm 2\%$.
3. Ensure the cable specifications meet the correct requirements for the specific installation. The distance between the installation site and the mains power supply will affect the cable thickness. Follow the 17th edition wiring regulations to select the cables, circuit breakers and circuit breakers.

Earthing and Over Current Protection

In order to prevent electrical shock in case of leakage from unit, install the heat pump according to current electrical wiring regulations.

1. Do not frequently interrupt the voltage supply to the heat pump as this may result in a shorter life expectancy of the heat pump.
2. When installing over current protection, ensure that the correct current rating is met for this specific installation.
3. The compressor, fan coil unit and heat pump water pump all have AC- contactors and thermo relay protection. Therefore, in the process of installation and debugging, firstly measure each of the components' current, and then adjust the current protection range of the thermo relays.

Section 3

Operating Your Heat Pump

Carel LCD User-Friendly Interface Controller

General Instructions

The Carel operation panel features:

- 1. Touch keys for higher operating sensitivity and unlimited key operations.
- 2. Minimal electromagnetic susceptibility and interference.
- 3. Stylish appearance of easy viewing purposes.

Controller Panel



Operating Controller

Keys Explanation:

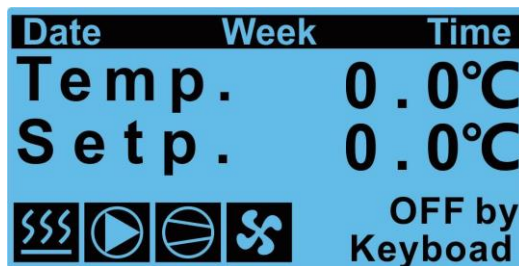

Icons:

Heating mode / Pump / Compressor / Fan / Defrost Cooling mode



Buttons:

Alarm / Exit / Menu & Confirm / Select / Settings



Controller Set-Up

1. On / Off Setting:

Press  to access menu

Use   buttons to select Unit On / Off setting

Press  to confirm selection

Use   Buttons to select On / Off mode

Press  to confirm.





2. Mode Selection:

Modes Available - Heating / Hot Water / Cooling / Heating + Hot Water / Hot Water + Cooling

Ensure unit is in Off mode first

Press  to access menu

Use   buttons to select User Mask

Press  to confirm selection

Press   Button to switch mode

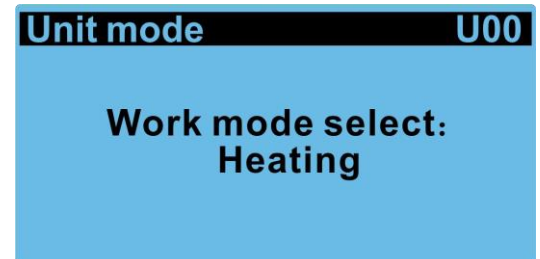

Press  to confirm





3. Time Zone / Clock Settings:

If the internal time clock is being used to control, heating / water or cooling times it can be set using the following procedure. If it is not being used and you are using external controls, the fields should be left blank and turned off.

Press  to access menu

Using   buttons select Time Zone / Clock

Press  to confirm

Use   Buttons to change the settings

Press  to confirm.

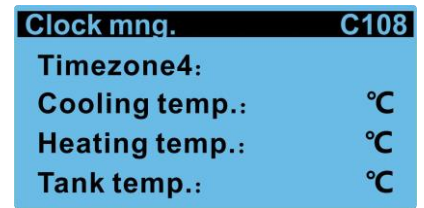
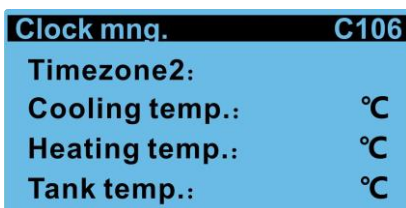
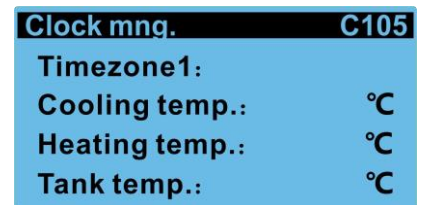
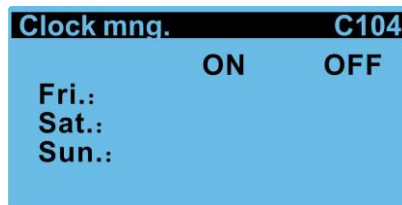
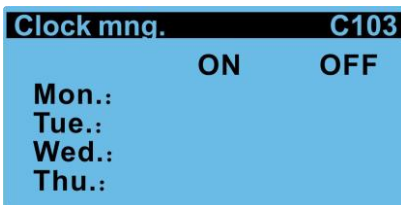
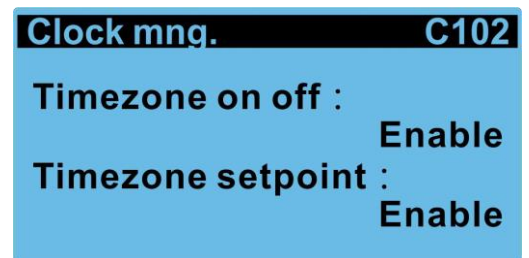
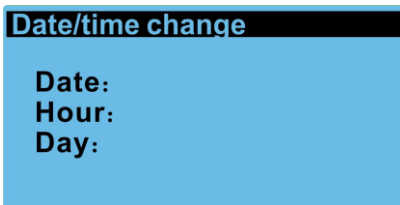

Upto 3 time zones can be set over 7 weekdays.
The temperature setpoints can also change based on the time zone.

Ask you installation engineer for advice on settings for the best efficiencies.

Engineer Settings - These should be set by your installation engineer

(Altering these settings can impact system efficiency)

4. Main Temperature Settings

Heating setp. = Heating / Buffer Temperature
Default 45c (Temperature of the supplied heating / buffer probe)

Cooling setp. = Cooling / Buffer Temperature
Default 12c (Temperature of the supplied heating / buffer probe)

Hotwater setp. = Hot Water Temperature
Default 50c (Temperature of the supplied hot water probe)

Setpoint U01

Heating setp.:
Cooling setp.:
Hotwater setp.:

5. Differential Temperature Settings:

Hotwater setp.
Temp. diff. = (Default 5c)
(Temperature differential before restart)
Stop temp diff. = (Default 0c)
(Buffer range to optimise compressor frequency)

Cool water setp.
Temp. diff. = (Default 5c)
(Temperature differential before restart)
Stop temp diff. = (Default 2c)
(Buffer range to optimise compressor frequency)

Setpoint U02

Hot water step.
Temp. diff.: +RR.R°C
Stop temp.diff.: +RR.R°C

Setpoint U03

Cool water step.
Temp. diff.: +RR.R°C
Stop temp.diff.: +RR.R°C

6. PID Settings:

Kp. = (Default 5c)
(Proportional control of frequency adjustment)

Setpoint U04

PID management
Kp: +RRR.R°C
Integral: IIIIs
Differential: IIIIs

7. Pump Control:

Pump work: = (Default Demand)
 (Pump stops after reaching set temperature)
Pump Auto: = (Default Enable)
 (PWM control)
Delta temp. set = (Default 5c)
 (PWM delta control)

PUMP control		U05
Pump work:	Demand	
Pump Auto:	DISABLE	

8. Other Settings:

User configure U06:

(Weather Compensation See Pages 25, 26)

Fan Mode: = (Default Daytime)
 Daytime - Full Frequency Operation
 Night (Low Noise) – Low Frequency Operation
 Low Speed (Full Weather Compensation)
 – Automatically Changes Frequency According to Ambient

Enable heater: = (Default Enable)
 (AUX. HTG Output)
Enable chassis/crank heater = (Default Enable)

Heater Control U07:

Comp.delay: = (Default 60min)
 (Compressor running time before AUX. HTG control)
Ext.temp. setp: = (Default 5c)
 (AUX. HTG is triggered below this setpoint)

Pump control		U08
Delta temp. set:	+RR.R°C	

User configure		U06
Fan mode:	Low speed	
Enabla heater:	Disable	
Enable chassis/crank heater:	Disable	

User configure U09:

Auto Start = (Default Enable)
 (Restart in previous working condition following power failure)

AmbTempSwitch U10:

Enable Switch: = (Default Enable)
 (Working mode changes automatically based on ambient temperature)
AutoTemp Switch
Setp: = (Default 20c)
 (When ambient temperature goes above setpoint working mode changes)
Amb Tem.diff: = (Default 4c)
 (Differential to change working mode)

Heater control		U07
Comp.delay:	Illmin	
Ext.temp. step.:	+RR.R°C	

User configure		U09
Auto start:	Enable	

AmbTemp Switch		U10
Enable Switch :	Disable	
AmbTemp Switch		
Setp:	+RR.R°C	
Amb Tem.diff:	+RR.R°C	

9. Input / Output Readings:

Press  to access menu

Use \uparrow \downarrow buttons to select I/O mask

Press  to confirm

Use \uparrow \downarrow Buttons to scroll the I/O's

M02

**Press ENTER to
switch
I/O mask**

Input/Output Sn01

B1: Inlet temp. +rrr.r°C
 B2: Outlet temp. +rrr.r°C
 B3: Ext temp. +rrr.r°C

Input/Output Sn02

B4: Disch. gas temp. +rrr.r°C
 B5: Suct. gas temp. +rrr.r°C
 B6: Disch. press +rr.r bar

Input/Out Sn03

B7: Suct. press. +rr.r bar
 B8: Hotwater temp. +rrr.r°C
 B9: Coil temp. +rrr.r°C

Input/Output Sn04

B10: EVI suct. temp. trrr.r
 +rrr.r°C
 B12: EVI evap.press.
 =+rr.rbar

Input/Output Sn05

Digit input status
 ID1: Flow switch
 ID2: Remote switch
 ID3: Termin Switch

Input/Output Sn06

Digit.input status
 ID4: Cooling linkage
 ID5: Phase. switch
 ID6: Heating linkage

Input/Output Sn07

Digit.output status
 D01: Fan high speed
 D02: Fan low speed
 D03: 4 way valve

Input/Output Sn08

Digit.output status
 D04: Pump
 D05: Three valve
 D06: Crank heater

Input/Output Sn09

Digit.output status
 D07: Chassis heater
 D08: Terminal pump
 D09: Heater

Weather Compensation

Your Cool Energy inverTech heat pump is equipped with intelligent weather compensation features. This means your heat pump will adapt itself automatically based on the ambient temperature outside and the system demand.

So for example if the temperature outside is warmer, it will lower the flow temperature to your heating system and if its colder it will increase it automatically. This greatly improves the efficiency of your heating system and we would recommend this is left turned on. Your installation engineer will discuss the best possible settings for your property on installation.

Please see below the logic of the weather compensation and setpoints:

(As per setting - User configure U06 on page 23.)

Modes available to select:

- Day mode:** According to the ambient temperature and load requirements, the compressor runs at the maximum frequency, and the fan runs at the maximum speed – **Select for best system response times.**
- Night mode:** During the period from 20:00 to 8:00 of the real-time clock, the maximum speed of the fan shall not exceed 500 rpm, and the maximum speed of the compressor shall not exceed 50Hz. These two parameters can be adjustable, and other periods are in accordance with the day mode run. – **Select for quietest operation**
- Low speed mode:** As shown in the logic below, outside ambient temperatures / heat pump operation modes correspond to compressor maximum speeds and temperature setpoints. – **Select for best system efficiency**

Logic of operation and setpoints:

Compressor Frequency:

	Ambient Temperature	Compressor max frequency setpoint: (rps)
Heating / Hot water	$9 < \text{AmbTemp}$	50
	$4 < \text{AmbTemp} \leq 9$	60
	$-3 < \text{AmbTemp} \leq 4$	60
	$-9 < \text{AmbTemp} \leq -3$	65
	$-15 < \text{AmbTemp} \leq -9$	65
	$\text{AmbTemp} \leq -15$	70
Cooling	$38 < \text{AmbTemp}$	65
	$33 < \text{AmbTemp} \leq 38$	65
	$30 < \text{AmbTemp} \leq 33$	60
	$26 < \text{AmbTemp} \leq 30$	60
	$\text{AmbTemp} \leq 26$	55

Ambient Temperature / System Water Temperature:

	Ambient Temperature Setpoint:		Water Temperature Setpoint:	
Heating	X1	-10	Y1	45
	X2	0	Y2	40
	X3	10	Y3	35
	X4	20	Y4 (User heating set point)	30
Cooling	X1	20	Y1 (User cooling set point)	15
	X2	25	Y2	15
	X3	30	Y3	12
	X4	35	Y4	12
Hot water	X1	0	Y1	50
	X2	10	Y2	50
	X3	20	Y3	45
	X4	30	Y4 (User hot water set point)	45

Settings according to weather compensation graphs:

Hot Water:

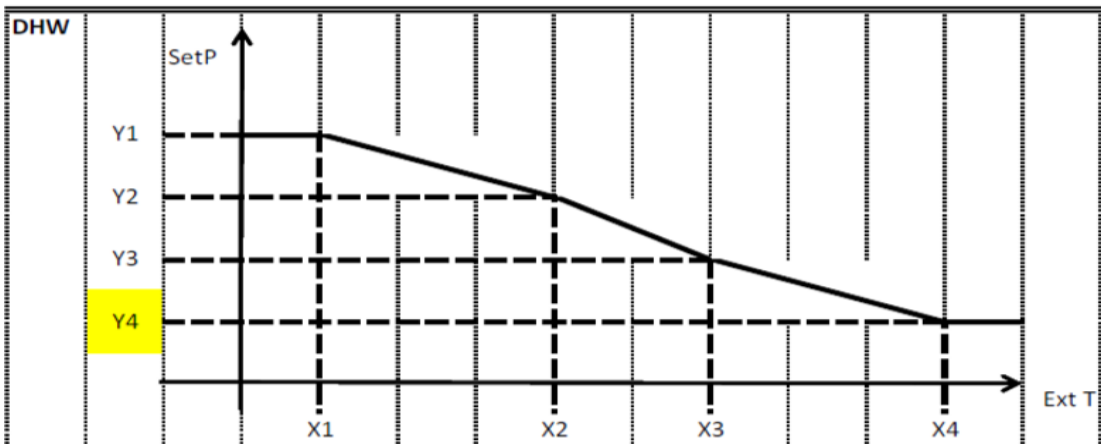

Heating:

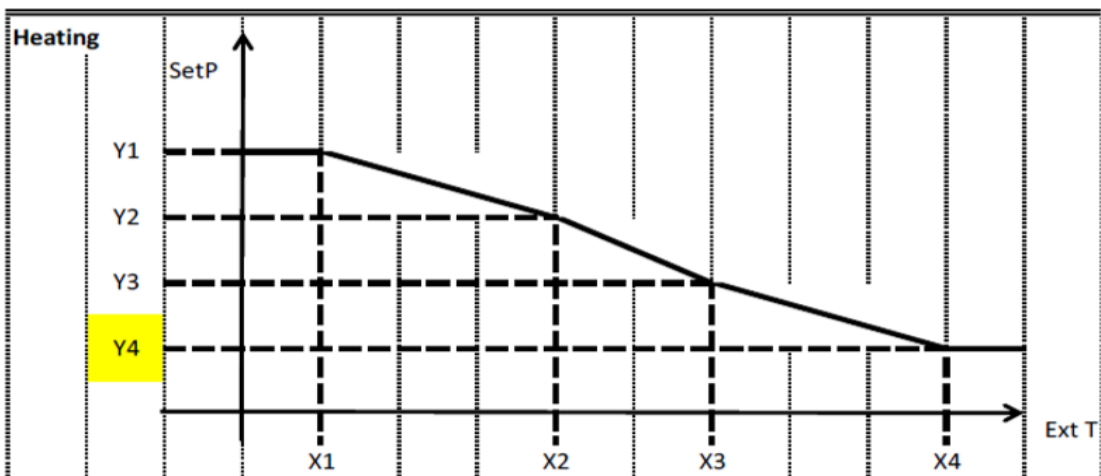



General Operating Guide

Initial Start-Up Precautions

First boot-strap and running state checks.

1. To ensure the power to the unit is at the correct voltage.
2. Unit electrical connections: Check if power supply wire connections are okay; if earth wire is properly connected; check if water pump and other chain devices are properly connected.
3. Water pipes, heat emitters are check for leaks.
4. Check water system: make sure the water flow is adequate and there is no air or leakages. (See Page 31.)
5. Check systems system settings are set at recommended default values.
6. First boot-strap or starting up again after being shut down for a long time, stop, ensure power is on ahead and heating at least 12 hours for crankcase (local loop temperature is zero). Water pump starts up first, fan starts up, and then compressor starts up and begins regular operation.
7. Running checks: check the following items:
 - a. Input and output water temperature.
 - b. Water flow rate.
 - c. Running electric current of compressor and fan.
 - d. High and low-pressure value when heating is running

 **CAUTION** – Refrain from using this heat pump if any technical components have been in contact with water. Immediately call a qualified service technician to inspect the heat pump.

 **CAUTION** – Keep all objects clear from above the heat pump. Blocking air flow could damage the unit and may void the warranty.

Users Guide

1. Rights and Responsibility

1.1 To ensure you have the service guarantee period, only qualified heating engineers can install and repair the unit. If you infract this request and cause any loss and damage, our company will not be held responsible. Please refer to your warranty card for further information.

2. User Guide

2.1 All safety protection devices are set in unit before leaving the factory, don't adjust it by yourself.

2.2 Units have been charged with refrigerant and lubricating oil, if needed owing to a leak; please refer to the charging quantity on nameplate.

2.3 The external water pump must be connected to the output from the unit.

2.4 Use antifreeze / glycol when the environment temperature is less than zero in winter.

2.5 Safety Precautions

- a. Unit must be installed by a competent person, plumber or heating engineer.
- b. Please check that power supply corresponds with unit size.
- c. The main power switch of unit should have earth leakage protector; the power cable must meet the unit power requirements.
- d. Unit must have a ground wire; don't use the unit if there is no ground wire.
- e. Don't use the unit if the fan grille/ fence has been removed.
- f. To avoid electric shock or fire, don't store or use, oil paint, petrol, combustible gas or liquid around the unit; don't throw water or other liquid on to the unit and don't touch the unit with wet hands.
- g. Don't adjust the switch, valve, controller or internal data without permission of customer support team.
- h. If a safety protection device is activated at start up, please contact the customer engineer or support team.

Product Protection Codes:

AL001	Too many mem writings
AL002	Retain mem write error
AL003	Inlet probe error
AL004	Outlet probe error
AL005	Ambient probe error
AL006	Condenser coil temp
AL007	Water flow switch
AL008	Phase sequ.prot.alarm
AL009	Unit work hour warning
AL010	Pump work hour warning
AL011	Comp.work hour warning
AL012	Cond.fan work hourWarn
AL013	Low superheat - Vlv.A
AL014	Low superheat - Vlv.B
AL015	LOP - Vlv.A
AL016	LOP - Vlv.B
AL017	MOP - Vlv.A
AL018	MOP - Vlv.B
AL019	Motor error - Vlv.A
AL020	Motor error - Vlv.B
AL021	Low suct.temp. - Vlv.A
AL022	Low suct.temp. - Vlv.B
AL023	High condens.temp.EVD
AL024	Probe S1 error EVD
AL025	Probe S2 error EVD
AL026	Probe S3 error EVD
AL027	Probe S4 error EVD
AL028	Battery discharge EVD
AL029	EEPROM alarm EVD

Product Protection Codes – Continued

AL030	Incomplete closing EVD
AL031	Emergency closing EVD
AL032	FW not compatible EVD
AL033	Config. error EVD
AL034	EVD Driver offline
AL035	BLDC-alarm:High startup DeltaP
AL036	BLDC-alarm:Compressor shut off
AL037	BLDC-alarm:Out of Envelope
AL038	BLDC-alarm:Starting fail wait
AL039	BLDC-alarm:Starting fail exceeded
AL040	BLDC-alarm:Low delta pressure
AL041	BLDC-alarm:High discharge gas temp
AL042	Envelope-alarm:High compressor ratio
AL043	Envelope-alarm:High discharge press.
AL044	Envelope-alarm:High current
AL045	Envelope-alarm:High suction pressure
AL046	Envelope-alarm:Low compressor ratio
AL047	Envelope-alarm:Low pressure diff.
AL048	Envelope-alarm:Low discharge pressure
AL049	Envelope-alarm:Low suction pressure
AL050	Envelope-alarm:High discharge temp.
AL051	Power+ alarm:01-Overcurrent
AL052	Power+ alarm:02-Motor overload
AL053	Power+ alarm:03-DCbus overvoltage
AL054	Power+ alarm:04-DCbus undervoltage
AL055	Power+ alarm:05-Drive overtemp.
AL056	Power+ alarm:06-Drive undertemp.
AL057	Power+ alarm:07-Overcurrent HW
AL058	Power+ alarm:08-Motor overtemp.
AL059	Power+ alarm:09-IGBT module error
AL060	Power+ alarm:10-CPU error
AL061	Power+ alarm:11-Parameter default

Product Protection Codes – Continued

AL062	Power+ alarm:12-DCbus ripple
AL063	Power+ alarm:13-Data comm. Fault
AL064	Power+ alarm:14-Thermistor fault
AL065	Power+ alarm:15-Autotuning fault
AL066	Power+ alarm:16-Drive disabled
AL067	Power+ alarm:17-Motor phase fault
AL068	Power+ alarm:18-Internal fan fault
AL069	Power+ alarm:19-Speed fault
AL070	Power+ alarm:20-PFC module error
AL071	Power+ alarm:21-PFC overvoltage
AL072	Power+ alarm:22-PFC undervoltage
AL073	Power+ alarm:23-STO DetectionError
AL074	Power+ alarm:24-STO DetectionError
AL075	Power+ alarm:25-Ground fault
AL076	Power+ alarm:26-Internal error 1
AL077	Power+ alarm:27-Internal error 2
AL078	Power+ alarm:28-Drive overload
AL079	Power+ alarm:29-uC safety fault
AL080	Power+ alarm:98-Unexpected restart
AL081	Power+ alarm:99-Unexpected stop
AL082	Power+ safety alarm:01-Current meas.fault
AL083	Power+ safety alarm:02-Current unbalanced
AL084	Power+ safety alarm:03-Over current
AL085	Power+ safety alarm:04-STO alarm
AL086	Power+ safety alarm:05-STO hardware alarm
AL087	Power+ safety alarm:06-PowerSupply missing
AL088	Power+ safety alarm:07-HW fault cmd.buffer
AL089	Power+ safety alarm:08-HW fault heater c.
AL090	Power+ safety alarm:09-Data comm. Fault
AL091	Power+ safety alarm:10-Compr. stall detect
AL092	Power+ safety alarm:11-DCbus over current
AL093	Power+ safety alarm:12-HWF DCbus current

Product Protection Codes – Continued

AL094	Power+ safety alarm:13-DCbus voltage
AL095	Power+ safety alarm:14-HWF DCbus voltage
AL096	Power+ safety alarm:15-Input voltage
AL097	Power+ safety alarm:16-HWF input voltage
AL098	Power+ safety alarm:17-DCbus power alarm
AL099	Power+ safety alarm:18-HWF power mismatch
AL100	Power+ safety alarm:19-NTC over temp.
AL101	Power+ safety alarm:20-NTC under temp.
AL102	Power+ safety alarm:21-NTC fault
AL103	Power+ safety alarm:22-HWF sync fault
AL104	Power+ safety alarm:23-Invalid parameter
AL105	Power+ safety alarm:24-FW fault
AL106	Power+ safety alarm:25-HW fault
AL107	Power+ safety alarm:26-reseved
AL108	Power+ safety alarm:27-reseved
AL109	Power+ safety alarm:28-reseved
AL110	Power+ safety alarm:29-reseved
AL111	Power+ safety alarm:30-reseved
AL112	Power+ safety alarm:31-reseved
AL113	Power+ safety alarm:32-reseved
AL114	Power+ alarm:Power+ offline
AL115	EEV alarm:Low superheat
AL116	EEV alarm:LOP
AL117	EEV alarm:MOP
AL118	EEV alarm:High condens.temp.
AL119	EEV alarm:Low suction temp.
AL120	EEV alarm:Motor error
AL121	EEV alarm:Self Tuning
AL122	EEV alarm:Emergency closing
AL123	EEV alarm:Temperature delta
AL124	EEV alarm:Pressure delta
AL125	EEV alarm:Param.range error

Product Protection Codes – Continued

AL126	EEV alarm:ServicePosit% err
AL127	EEV alarm:ValveID pin error
AL128	Low press alarm
AL129	High press alarm
AL130	Disc.temp.probe error
AL131	Suct.temp.probe error
AL132	Disc.press.probe error
AL133	Suct.press.probe error
AL134	Tank temp.probe error
AL135	EVI SuctT.probe error
AL136	EVI SuctP.probe error
AL137	Flow switch alarm
AL138	High temp. alarm
AL139	Low temp. alarm
AL140	Temp.delta alarm
AL141	EVI alarm:Param.range error
AL142	EVI alarm:Low superheat
AL143	EVI alarm:LOP
AL144	EVI alarm:MOP
AL145	EVI alarm:High condens.temp.
AL146	EVI alarm:Low suction temp.
AL147	EVI alarm:Motor error
AL148	EVI alarm:Self Tuning
AL149	EVI alarm:Emergency closing
AL150	EVI alarm:ServicePosit% err
AL151	EVI alarm:ValveID pin error

Section 4

Commissioning

- Ensure all pipes have been flushed with cleaner and are free of debris in accordance with Part L Building Regulations. (**Part L** refers to the **Domestic Heating Compliance Guide**. This states that the minimum provision in new and existing dwellings is: Thorough cleaning and flushing out before installing a new heating appliance. During final fill add the corrosion and scale formulation / Glycol as required.
- Water flow should be checked either by a flow metering device either fitted permanently or temporarily to the system. Or measuring the temperature differential between the flow and return pipes when the heat pump is running. The temperature differential should not exceed 5 degrees C. The heat pump itself does also incorporate a flow switch on the return pipe. If a low flow condition is detected, alarm code **AL137** will be displayed on the controller and will not reset until the flow has been restored.
- Visually check installation to ensure all pipework is complete and insulation is applied where required
- Check all electrical connections have been made and tested according to BS7671:2018
- Ensure system is filled and pressure is between 1 & 2 bar
- Ensure all system filters are free from debris
- Check all air has been vented from the system
- Turn all external heating controls and thermostats to on positions
- Activate the heat pump with the Carel control screen
- Check operation of external controls by turning zones on and off and thermostats up and down
- Allow heat pump to reach set temperatures for each zone
- Ensure heat pump settings are correct according to the factory defaults provided in Section 3.
- Set timeclocks and temperature settings to optimise efficiency for homeowner (Weather compensation mode is recommended)
- Fill in benchmark form with the installation details (p33)
- Demonstrate the system to the homeowner

Service & Maintenance – Service Engineer

Inspection and Service

Cool Energy air source heat pumps are designed and built to provide long life and performance, when installed and operated properly under normal conditions. Periodic inspections are important to keep your heat pump running safely and efficiently.

The basic requirements are:

- Clean the outdoor heat exchanger
- Straighten any evaporator fins with a fin comb if required
- Visual inspection for oil or leaks
- Test the primary system water with a refractometer to ensure adequate glycol concentrate
- Check the integrity of the pipework insulation
- Check for loose electrical connections
- Check heat pump control settings are correct for best performance
- Check system controls are set for best performance
- Check compressor operating current
- Complete service record (p34)

Homeowner Inspection

Cool Energy recommends that inspections on heat pumps are done frequently, especially after abnormal weather conditions. The following basic guidelines are suggested for your inspection:

1. Make sure the front of the unit is accessible for service.
2. Keep the top and surrounding areas of the heat pump clear of all debris.
3. Keep all plants and shrubs trimmed and away from the heat pump especially the area around the fan.
4. Keep lawn sprinklers from spraying on the heat pump to prevent corrosion and damage.
5. Ensure that the earth wire is always properly connected.
6. A water filter must be installed and maintained.
7. All the safety protection devices have been set up; please refrain from changing these settings. If any changes are needed, please contact our support team.
8. If the heat pump is installed under roof without a gutter, ensure that all measures are taken to prevent excessive water from entering the unit.
9. Do not use this heat pump if any electrical part has been in contact with water. Contact an authorized service technician.

Troubleshooting

Use the following troubleshooting information to resolve issues with your heat pump.



WARNING — RISK OF ELECTRICAL SHOCK OR ELECTROCUTION.



Ensure that all high voltage circuits are disconnected before commencing heat pump installation maintenance. Contact with these circuits could result in death or serious injury to users, installers or others.

- Keep your hands and hair clear of the fan blades to avoid injury.
- **DO NOT** attempt to adjust or service the unit without consulting your authorized installer/agent.
- **PLEASE** read the complete Installation and/or User's Guide before attempting to operate service or adjust the heater.
- **Your heat pump is equipped with an intelligent Carel control system**
It will try and overcome any problem by itself and automatically recovers from most fault conditions as well as power outages. If for any reason an alarm code is displayed starting AL*** on the controller screen.
Don't worry! -It will only display Alarm codes if it has shut down to protect itself from damage. Normally it will be something very simple such as low water pressure or a blocked filter. Please check the protection codes table in this manual and contact your installer in the first instance.

AIR TO WATER HEAT PUMP COMMISSIONING CHECKLIST

This Commissioning Checklist is to be completed in full by the competent person who commissioned the heat pump and associated equipment as a means of demonstrating compliance with the appropriate Building Regulations and then handed to the customer to keep for future reference.

Failure to install and commission this equipment to the manufacturer's instructions may invalidate the warranty but does not affect statutory rights.

Customer name:	Telephone number:
Address:	
Heat Pump Make and Model	
Heat Pump Serial Number	
Commissioned by (PRINT NAME):	Certified Operative Reg. No. [1]
Company name:	Telephone number:
Company address:	
Commissioning date:	
Building Regulations Notification Number (if applicable) [2]	

CONTROLS - SYSTEM AND HEAT PUMP (tick the appropriate boxes)			
Time and temperature control to heating	Room thermostat and programmer/timer	<input type="checkbox"/>	Programmable Roomstat
	Load/weather compensation	<input type="checkbox"/>	Optimum start control
Time and temperature control to hot water	Cylinder thermostat and programmer/timer	<input type="checkbox"/>	Combined with Heat pump main controls
Heating zone valves (including underfloor loops)	Fitted	<input type="checkbox"/>	Not required
Hot water zone valves	Fitted	<input type="checkbox"/>	Not required
Thermostatic radiator valves	Fitted	<input type="checkbox"/>	Not required
Heat Pump Safety Interlock [3]	Built In	<input type="checkbox"/>	Provided
Outdoor Sensor	Fitted	<input type="checkbox"/>	Not required
Automatic bypass to system	Fitted	<input type="checkbox"/>	Not required
Buffer Vessel Fitted	Yes <input type="checkbox"/>	No <input type="checkbox"/>	If YES Volume: <input type="text"/> Litres

ALL SYSTEMS	
The heating system has been filled and pressure tested	Yes <input type="checkbox"/>
Expansion vessel for heating is sized, fitted & charged in accordance with manufacturer's instructions	Yes <input type="checkbox"/>
The heat pump is fitted on a solid/stable surface capable of taking its weight	Yes <input type="checkbox"/>
The system has been flushed and cleaned in accordance with BS7593 and heat pump manufacturer's instructions	Yes <input type="checkbox"/>
What system cleaner was used?	
What inhibitor was used?	Quantity <input type="text"/> litres
Is the system adequately frost protected?	Yes <input type="checkbox"/>

OUTDOOR UNIT	
Are all external pipeworks insulated?	Yes <input type="checkbox"/>
Is the fan free from obstacles and operational?	Yes <input type="checkbox"/>
Has suitable consideration been made for waste water discharge?	Yes <input type="checkbox"/>

CENTRAL HEATING MODE			
Heating Flow Temperature	<input type="text"/>	°C	Heating Return Temperature
			<input type="text"/>
			°C

DOMESTIC HOT WATER MODE Measure and Record:			
Is the heat pump connected to a hot water cylinder?	Unvented <input type="checkbox"/>	Vented <input type="checkbox"/>	Thermal Store <input type="checkbox"/>
Hot water has been checked at all outlets	Yes <input type="checkbox"/>	Have Thermostatic Blending Valves been fitted? <input type="checkbox"/>	Yes <input type="checkbox"/>
			Not required <input type="checkbox"/>

ADDITIONAL SYSTEM INFORMATION						
Additional heat sources connected:	<input type="checkbox"/>	Gas Boiler <input type="checkbox"/>	Oil Boiler <input type="checkbox"/>	Electric Heater <input type="checkbox"/>	Solar Thermal <input type="checkbox"/>	Other: <input type="text"/>

ALL INSTALLATIONS	
The heating, hot water and ventilation systems complies with the appropriate Building Regulations	Yes <input type="checkbox"/>
All electrical work complies with the appropriate Regulations	Yes <input type="checkbox"/>
The heat pump and associated products have been installed and commissioned in accordance with the manufacturer's instructions	Yes <input type="checkbox"/>
The operation of the heat pump and system controls have been demonstrated to the customer	Yes <input type="checkbox"/>
The manufacturer's literature, including Benchmark Checklist and Service Record, has been explained and left with the customer	Yes <input type="checkbox"/>

Commissioning Engineer's Signature
Customer's Signature
(To confirm satisfactory demonstration and receipt of manufacturer's literature)

Notes: [1] Installers should be members of an appropriate Competent Persons Scheme. [2] All installations in England and Wales must be notified to Local Area Building Control (LABC) either directly or through a Competent Persons Scheme. A Building Regulations Compliance Certificate will then be issued to the customer. [3] May be required for systems covered by G3 Regulations

© Heating and Hot Water Industry Council (HHIC)



SERVICE RECORD

It is recommended that your heating system is serviced regularly and that the appropriate Service Interval Record is completed.

Service Provider

Before completing the appropriate Service Record below, please ensure you have carried out the service as described in the manufacturer's instructions. Always use the manufacturer's specified spare part when replacing controls.

SERVICE 01		Date:	SERVICE 02		Date:
Engineer name:			Engineer name:		
Company name:			Company name:		
Telephone No:			Telephone No:		
Operative ID No:			Operative ID No:		
Comments:			Comments:		
.....				
.....				
.....				
Signature			Signature		
SERVICE 03		Date:	SERVICE 04		Date:
Engineer name:			Engineer name:		
Company name:			Company name:		
Telephone No:			Telephone No:		
Operative ID No:			Operative ID No:		
Comments:			Comments:		
.....				
.....				
.....				
Signature			Signature		
SERVICE 05		Date:	SERVICE 06		Date:
Engineer name:			Engineer name:		
Company name:			Company name:		
Telephone No:			Telephone No:		
Operative ID No:			Operative ID No:		
Comments:			Comments:		
.....				
.....				
.....				
Signature			Signature		
SERVICE 07		Date:	SERVICE 08		Date:
Engineer name:			Engineer name:		
Company name:			Company name:		
Telephone No:			Telephone No:		
Operative ID No:			Operative ID No:		
Comments:			Comments:		
.....				
.....				
.....				
Signature			Signature		
SERVICE 09		Date:	SERVICE 10		Date:
Engineer name:			Engineer name:		
Company name:			Company name:		
Telephone No:			Telephone No:		
Operative ID No:			Operative ID No:		
Comments:			Comments:		
.....				
.....				
.....				
Signature			Signature		



Cool Energy Holding Ltd.

163 Cleethorpe Road,
Grimsby,
DN31 3AX.

Email: sales@coolenergyshop.com

www.coolenergyshop.com

