

PHOTOVOLTAÏC  
SELF-CONSUMPTION

INSTALLATION MANUAL GSE GROUND SYSTEM

**GSE GROUND SYSTEM**<sup>TM</sup>**V3.2**

Ground Mounting System for framed PV modules

Functional, lightweight, aesthetic,  
quick to install, simple and universal !



CHUBB



# Table of contents

## **■ STEP BY STEP**

Mounting System Description.....	p.3
Tools needed for installation.....	p.3
Pieces nomenclature.....	p.4
Number of pieces per installation.....	p.5
Bar Z dimensions .....	p.6
Ground footprint GSE Ground System.....	p.7
Compatibility of the bars.....	p.8
System Mounting.....	p.9
Implementation advice.....	p.15
Example of system adaptation.....	p.16



# Mounting System Description

## On-Ground installation of PV modules, ideal for self-consumption

The **GSE GROUND SYSTEM** has been designed to allow the installation of 95% of photovoltaic modules on the ground. Its robustness and its material guarantee makes it a perfectly designed product for a quick and reliable execution.

- The system is less than 1.80 m high, so no administrative formalities are required for its implementation.
- Energy optimization of construction as part of the 2012 thermal regulation or self-consumption.
- Alternative to roof installations (lack of space, old roof, etc.).
- Sold in blocks of 2 to 6 panels or per piece, it can answer several uses :  
Complementary PV installation, self-consumption, installation in gardens, etc.

### Advantages

- Solves space problems:  
> Installation in portrait and not landscape for space reduction.
- Suitable for all gardens:  
> No problem with the height of the lawn, facilitates the mowing.
- Compatible with all module sizes
- Easy attachment of micro-inverters or optimizers
- Easy and safe to install  
> Ballasting possible with all types of materials.  
> No work on the roof.
- Compact and lightweight format
- 100 % recyclable
- Optional mounting plate for use of a protective box at the rear of the system

## Tools needed for Installation

### SCREW DRIVER

Couple de serrage réglable obligatoire



### SCREW TIPS

- 6 PANS TIP :  
ø 6mm  
ø 8mm  
ø 10mm

### SOCKET WRENCH

- 6 PANS TIP :  
ø 6mm  
ø 8mm  
ø 10mm



### TAPE MEASURER - PENCIL



### BALLASTING : GRAVELS, SAND, DIRT, CONCRETE SLAB, ETC.

# Pieces nomenclature

REF.	Code GSE	Description	Drawing
1	PROFIL_FOND_CAISSO	Box Base (thickness 1mm)	
2	PROFIL_CAISSON_FRO	Front and back of the box base (thickness 1mm)	
3	PROFILE_LATERAL_CA	Left and right side of the box base (thickness 1mm)	
4	EQUERRE_FRONTALE	Frontal view of bracket (thickness 3mm) – Z profile bottom part (thickness 3mm)	
5	EQUERRE ARRIERE	“Back” bracket view - Z profile top part (thickness 3mm)	
6	PROFILE_Z	“Z” PV support (thickness 3mm x L 2005mm)	
7	CORNIERE_L_FIXE	Corner Piece L (thickness 2mm) fixed length 550mm	
8	CORNIERE_L_AJUSTAB	Corner Piece L (thickness 2mm) adjustable length: delivered 1233mm	
9	BOULON_FIXE_CORNI	6 pans Bolt with binding washer - Corner Piece Fixation (48 screws per box)	
10	ECROUS_SERRAGE_AUT	6 Pans nut with autoblocking binding washer (coupled with bolt “9”)	
11	BOULONS_SERR8AUTOB	6 pans bolt with autoblocking binding washer - Try Square fixation (2 per try square)	
12	ECROUS Rond_SERRAG	6 pans nut with binding washer (coupled with bolt “11”)	
13	MODULE_PV	Chosen Module (800-1050 mm wide)*	
14	VIS_FIXA_MODULE	Rounded-Head Screw – Module fixation - “Z” Pan (4 per module)	
15	ECROUS Rond_SERRAGE	6 pans nut with autoblocking binding washer (coupled with screw “14”)	
16	CORNIERES_RACCOR	Junction Corner Piece for “Z” bar	
17	ECROUS Rond_SERRAG	6 pans bolt with autoblocking binding washer – For Z bar junction fixation (4 per Junction)	
18	BOULONS_SERR_AUTOB	6 pans nut with binding washer (coupled with bolt “17”)	
<b>OPTION_REAR_SUPPORT</b>			
19	OPTION_SUP_ARRIERE	6 pans bolt with autoblocking binding washer	
20	OPTION_SUP_ARRIERE	6 pans nut with autoblocking binding washer> Rear support bracket	
21	OPTION_SUP_ARRIERE	Rear support 200x429mm - Fixing protection boxAC/DC	

\*See P15 for specific dimension

In the case drilling in the PV module frame with a self-drilling screw, you'll need to replace references 14 and 15 with a 4/6 x 15 mm stainless steel screw. The bomb Cold Galvanizing provided can handle the edges of the profiles after installation

# Number of pieces per installation

GSE INTEGRATION REFERENCE	Color	Quantities			
		1L X 2C	1L X 4C	1L X 6C	+ 2C
1 PROFIL_FOND_CAISSO		2	2	3	1
2 PROFIL_CAISSON_FRO		4	4	6	2
3 PROFILE_LATERAL_CA		4	4	6	2
4 EQUERRE_FRONTALE		4	4	6	2
5 EQUERRE_ARRIERE		4	4	6	2
6 PROFILE_Z		2	4	6	2
7 CORNIERE_L_FIXE		4	4	6	2
8 CORNIERE_L_AJUSTAB		4	4	6	2
9 BOULON_FIXE_CORNI		96	96	144	48
10 ECROUS_SERRAGE_AUT		96	96	144	48
11 BOULONS_SERR_AUTOB		16	16	24	8
12 ECROUS Rond_SERRAG		16	16	24	8
13 MODULE_PV		2	4	6	2
14 VIS_FIXA_MODULE		8	16	24	8
15 ECROUSROND_SERRAGE		8	16	24	8
16 CORNIERES_RACCOR		0	2	4	2
17 ECROUS Rond_SERRAG		0	8	16	8
18 BOULONS_SERR_AUTOB		0	8	16	8
19 OPTION_SUP_ARRIERE		4	4	4	4
20 OPTION_SUP_ARRIERE		4	4 </td <td>4</td> <td>4</td>	4	4
21 OPTION_SUP_ARRIERE		1	1	1	1

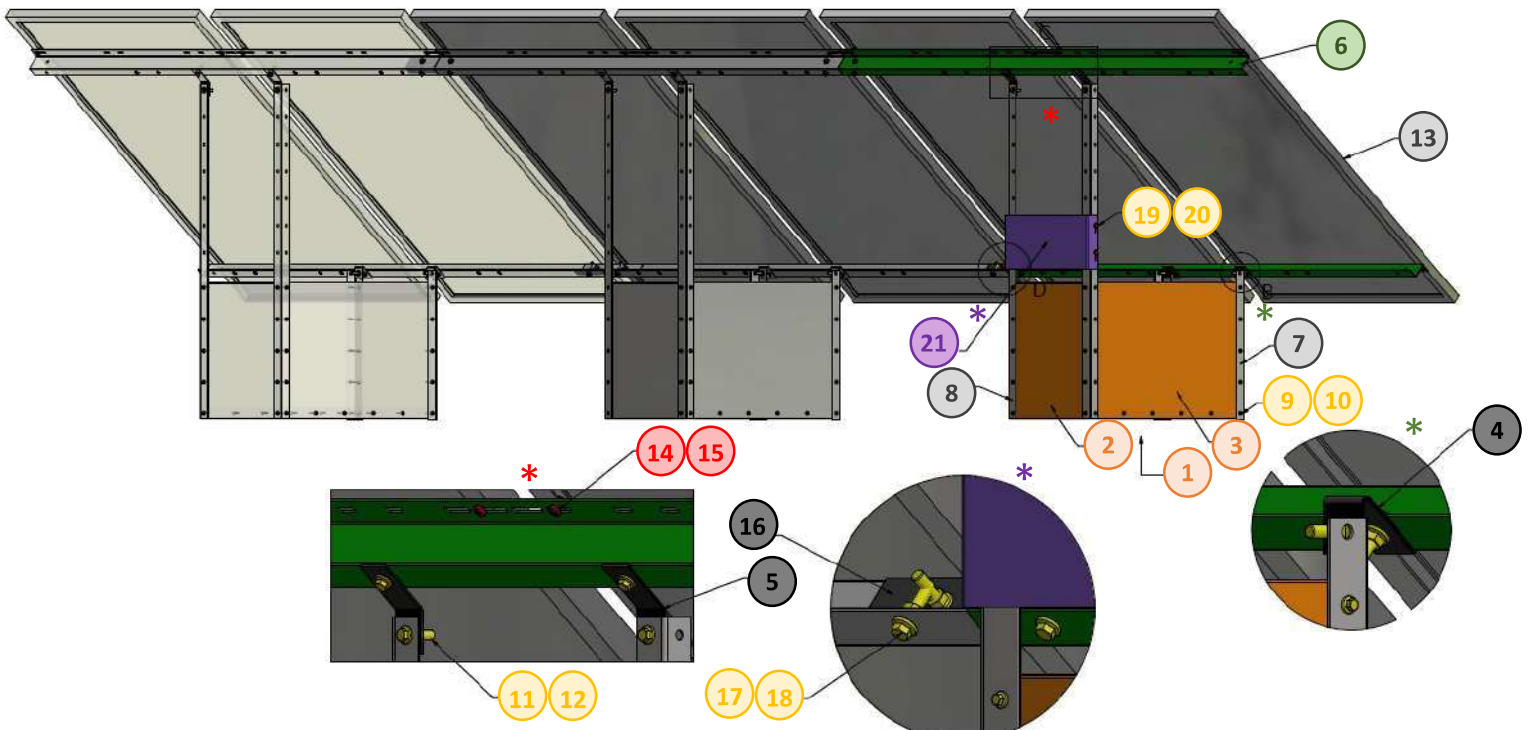

# Bar Z dimensions

## Holes nomenclature

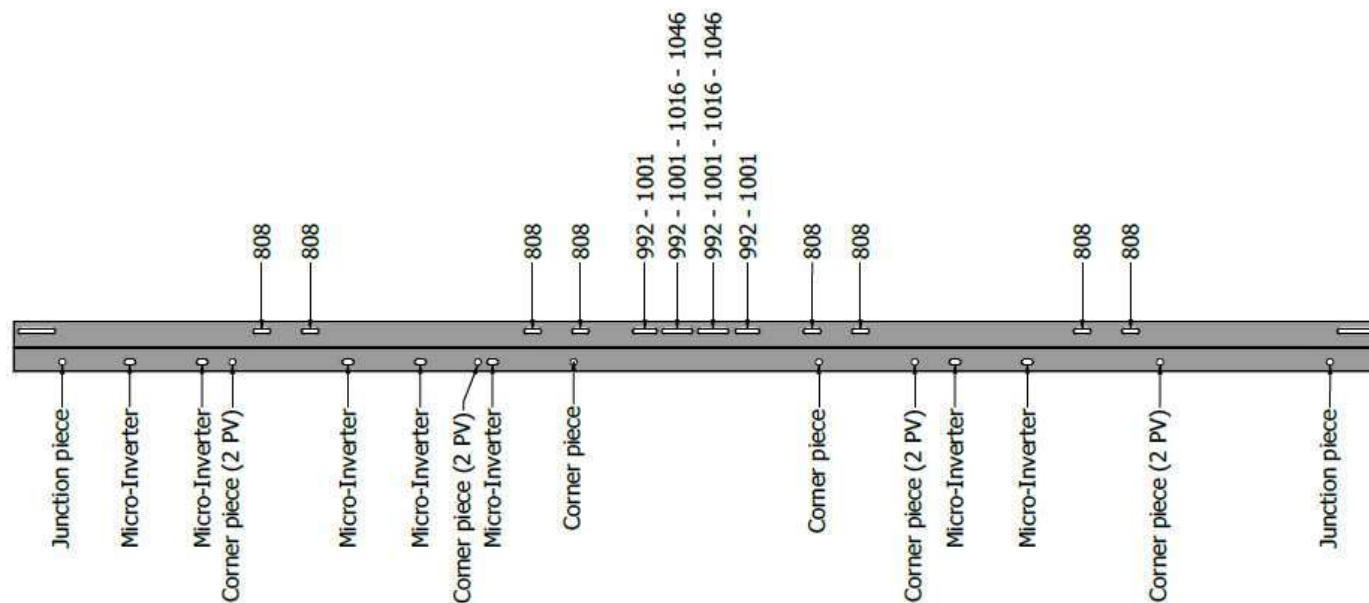

## Fixing holes dimensions

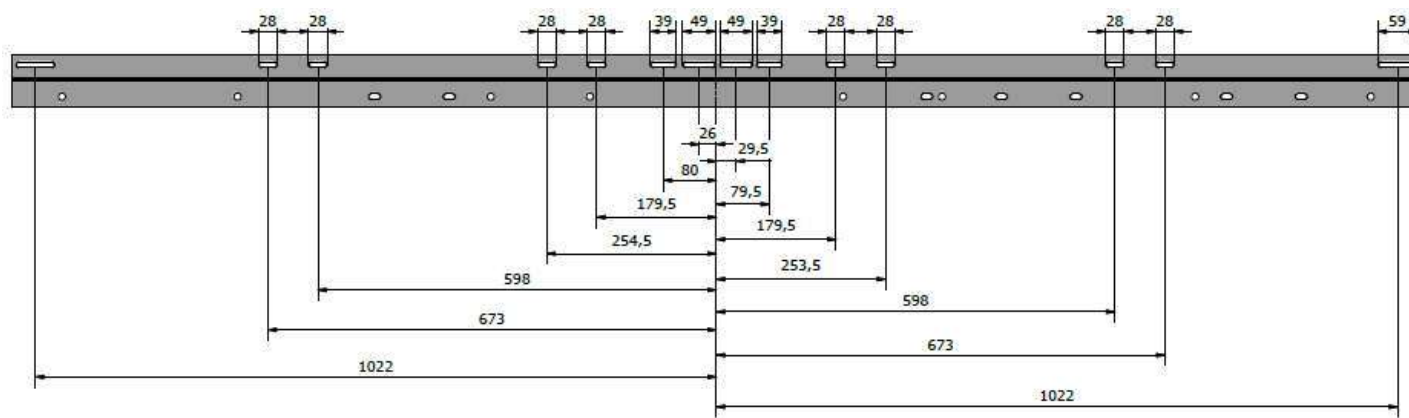

# Ground footprint GSE Ground System

1 x 2 portrait

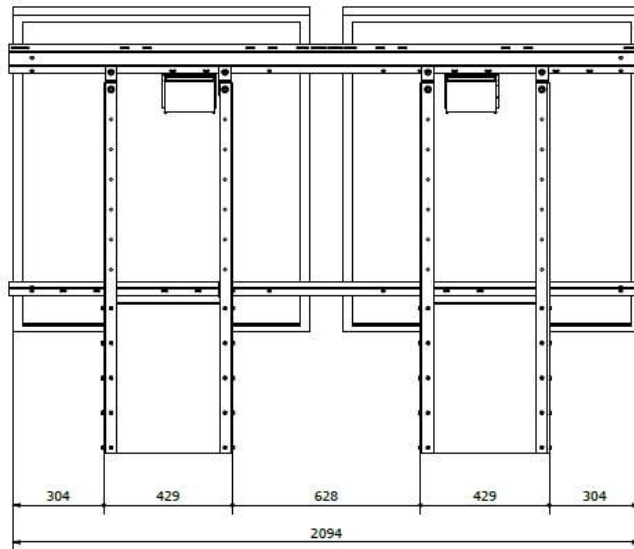

1 x 4 portrait

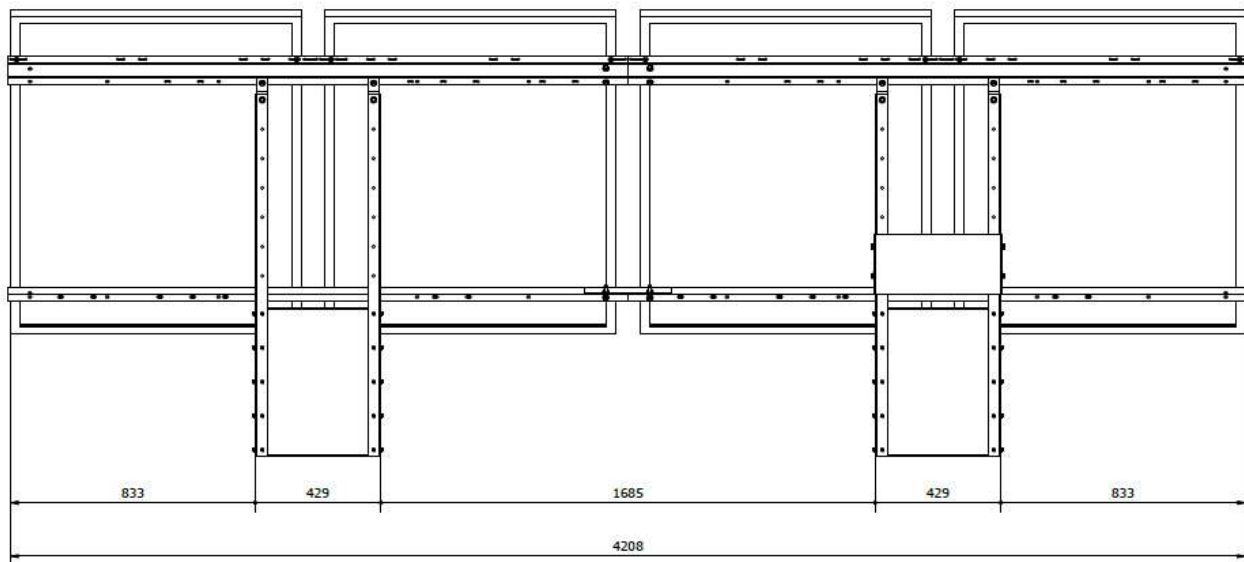

1 x 6 portrait

6342

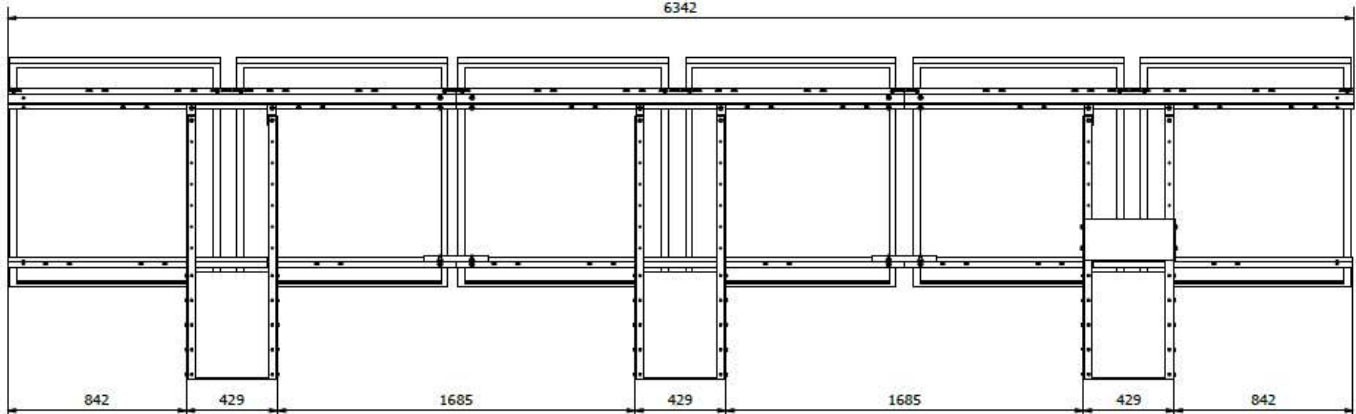

# Compatibility of the bars

5 X 808

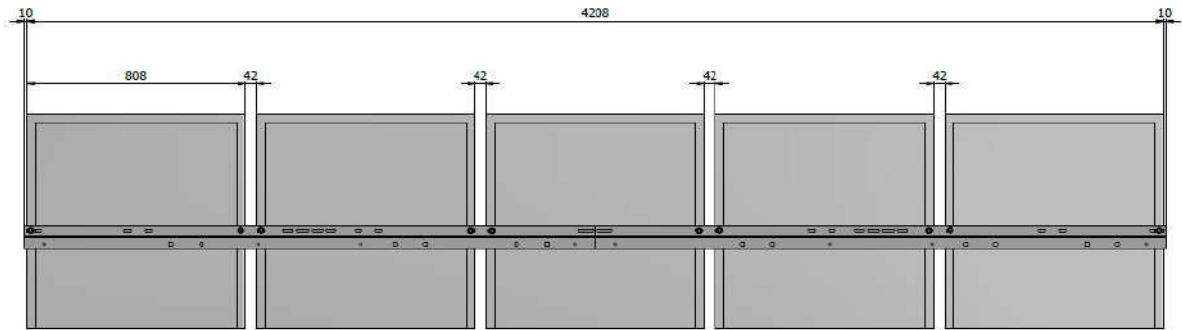

4 X 992

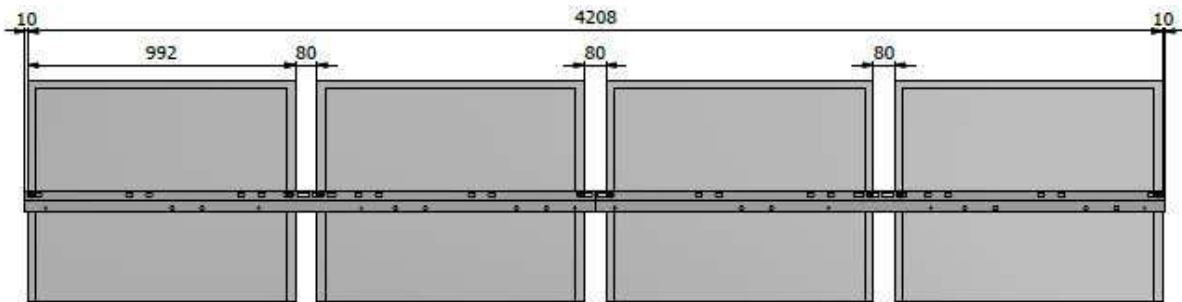

4 X 1001

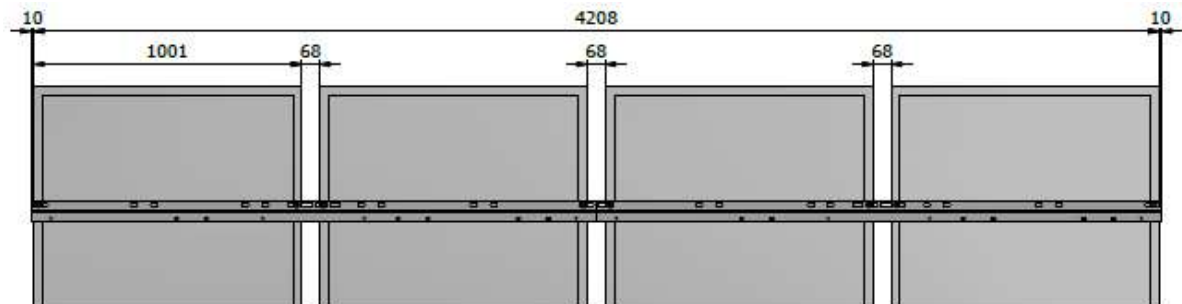

4 X 1016

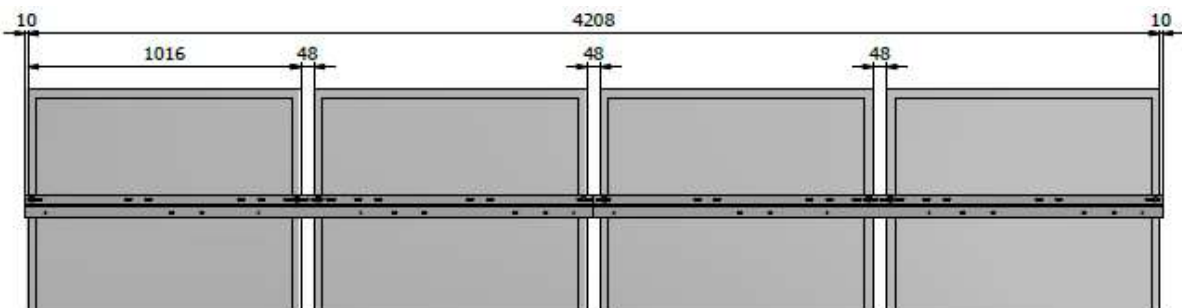

4 X 1046

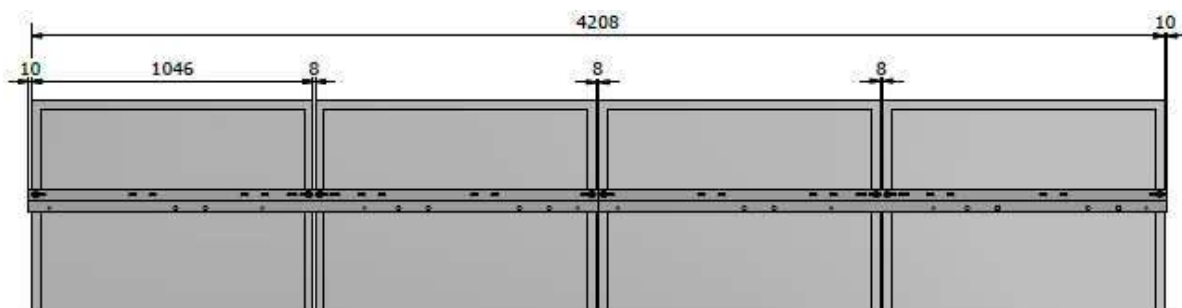



# Ground System Installation

■ MOUNT THE BOXES ONE BY ONE (REF. 1,2,3 AND SCREWS 9 ET 10)

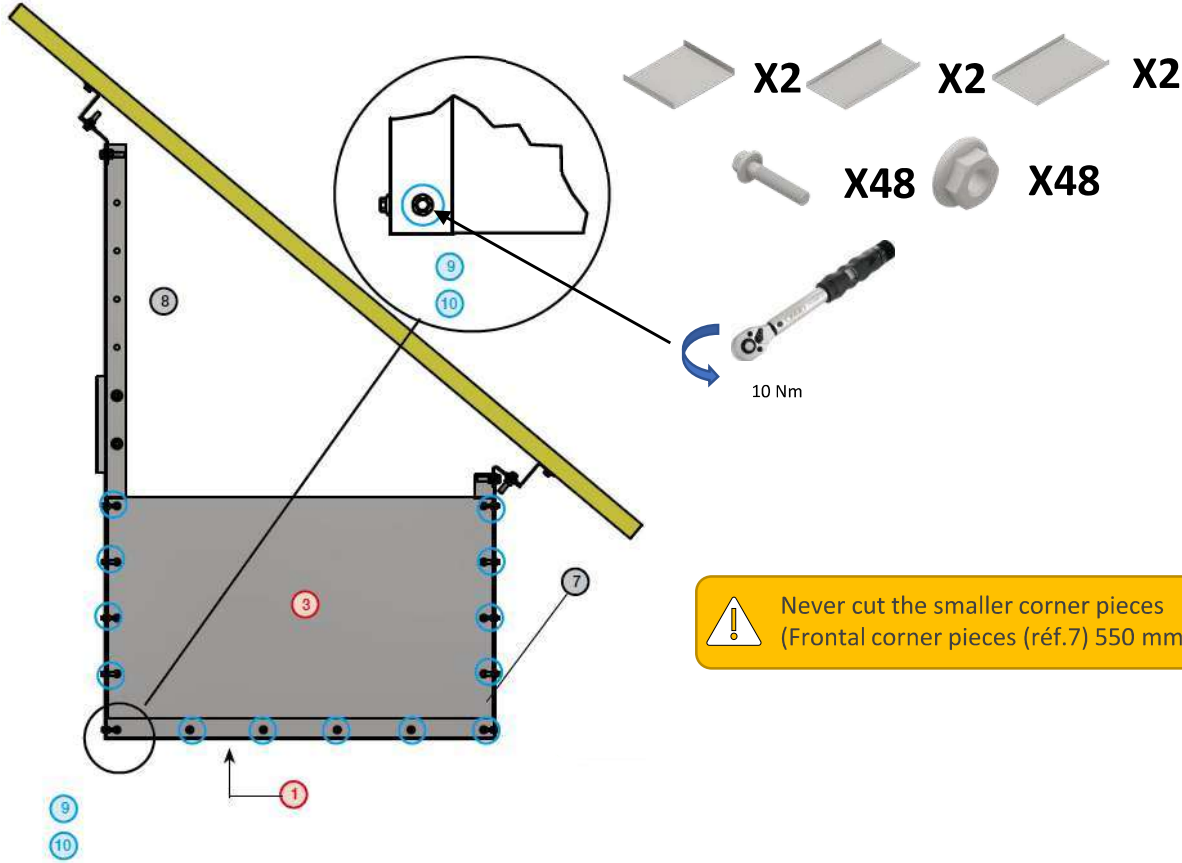

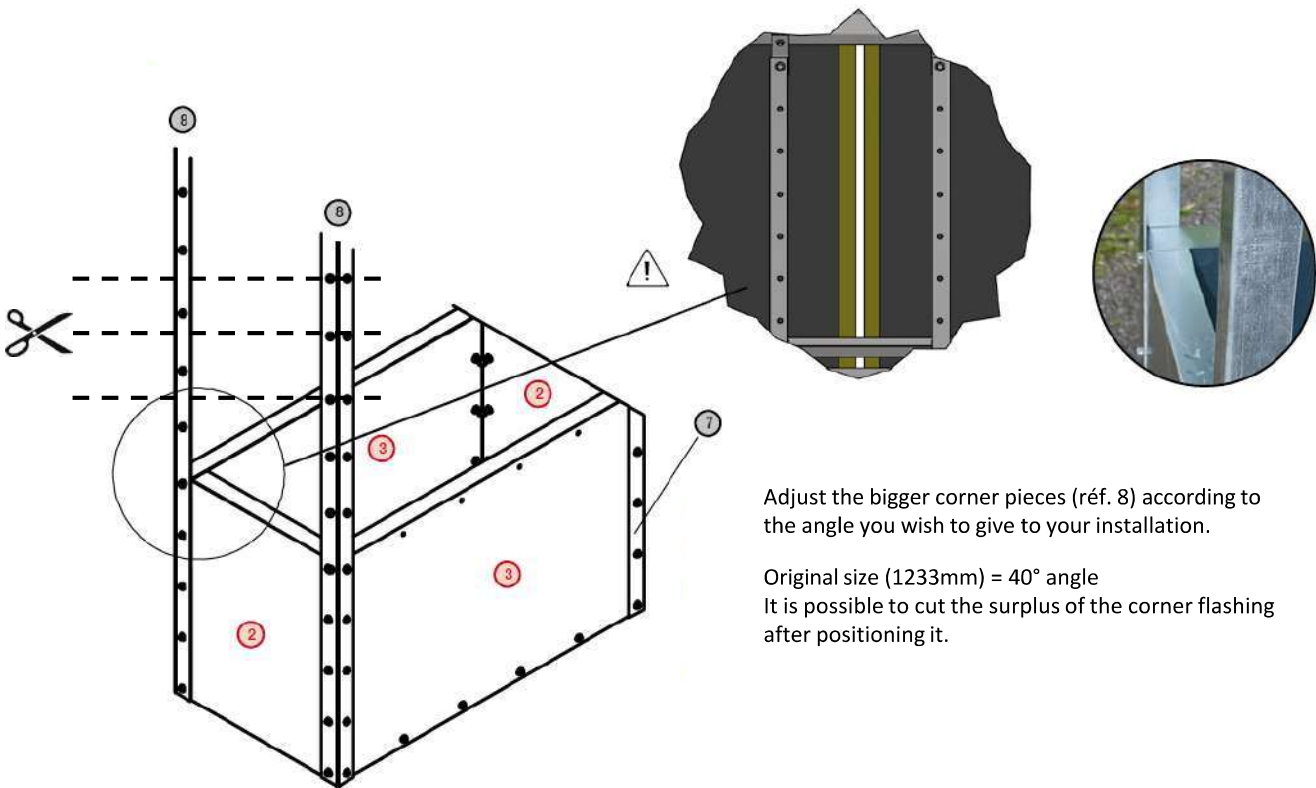

⚠ Never cut the smaller corner pieces (Frontal corner pieces (réf.7) 550 mm).

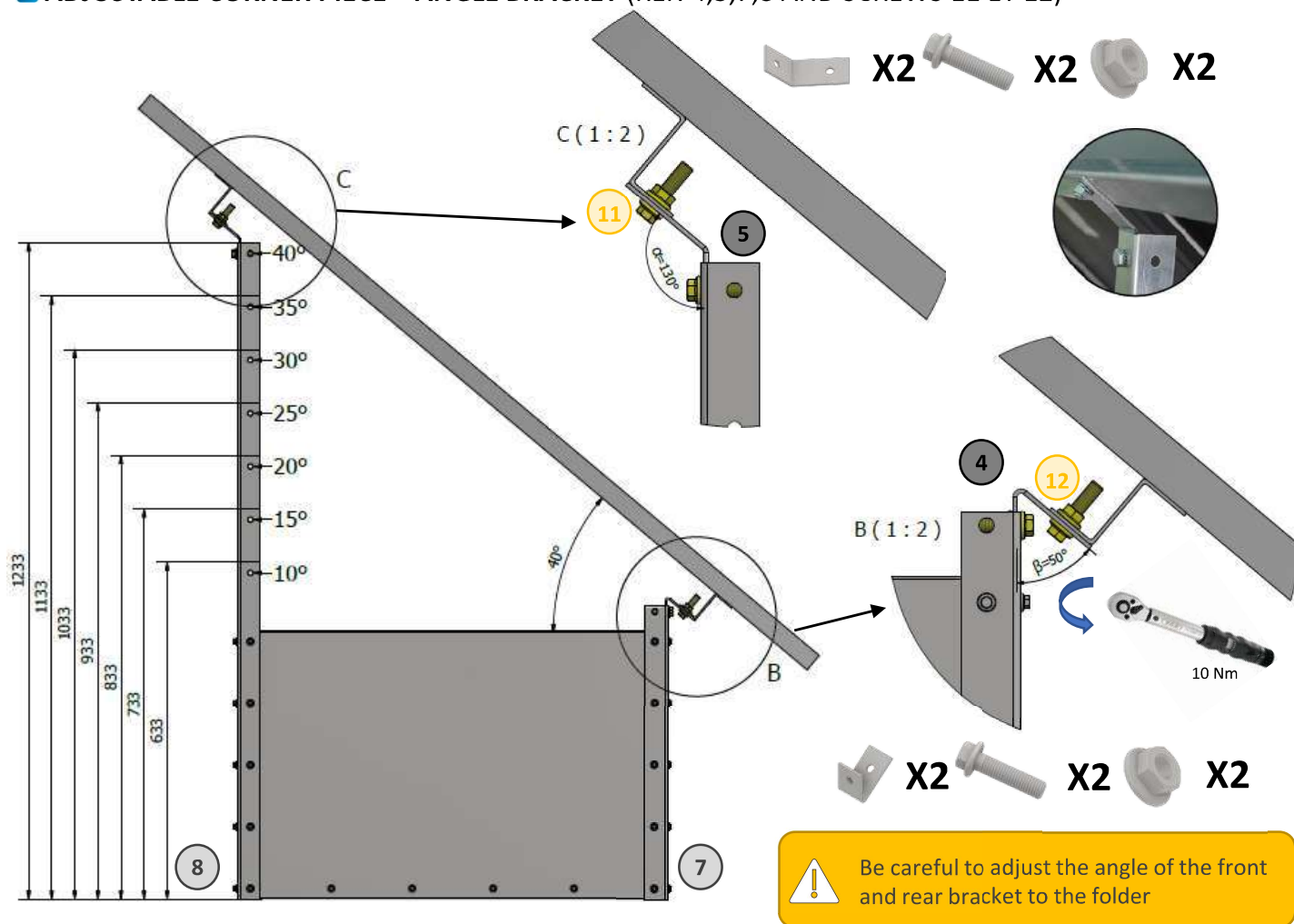

# Ground System Installation

■ **ADJUSTABLE CORNER PIECE – ANGLE BRACKET (REF. 4,5,7,8 AND SCREWS 11 ET 12)**



Tilting of the module(°)	Angle (°) $\alpha$ bracket 5 	Angle (°) $\beta$ bracket 4 	Adjustable corner piece length (mm)
40	130	50	1233
35,5	125,5	54,5	1133
30,6	120,6	59,4	1033
25	115	65	933
19	109	71	833
12,4	102,3	77,7	733
5,4	95,4	84,6	633

# Ground System Installation

**ASSEMBLE THE BRACKETS AND THE «Z» BAR**  
**OPTION 1 (REF. 6, 14, 15, 16, 17, 18)**

Position the Z bar to locate the modules fixation points.  
 It is possible to adjust this Z bar to the exact size of the 4 modules by adjusting the splint (cf. sheet 7).

B (1:2)

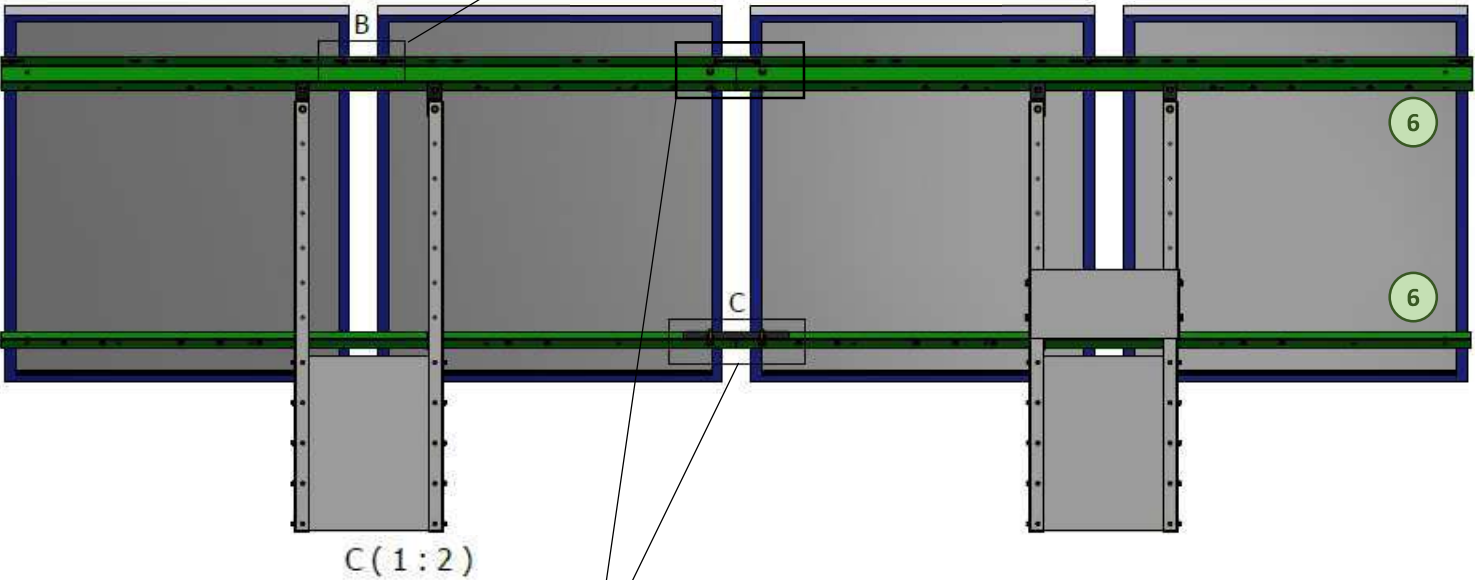
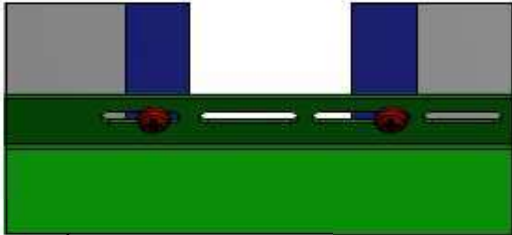

C (1:2)

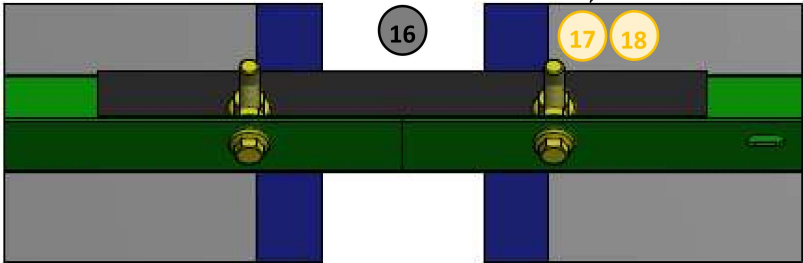

Assemble the bar using the supplied splint (ref. 16, 17, 18)  
 Adjust the size of your installation, if needed, to the size of your modules by making sure you're leaving a 5mm space between the modules for wind passage.



# Ground System Installation

## ATTACH THE MODULES (REF. 13, 14, 15) – OPTION 1

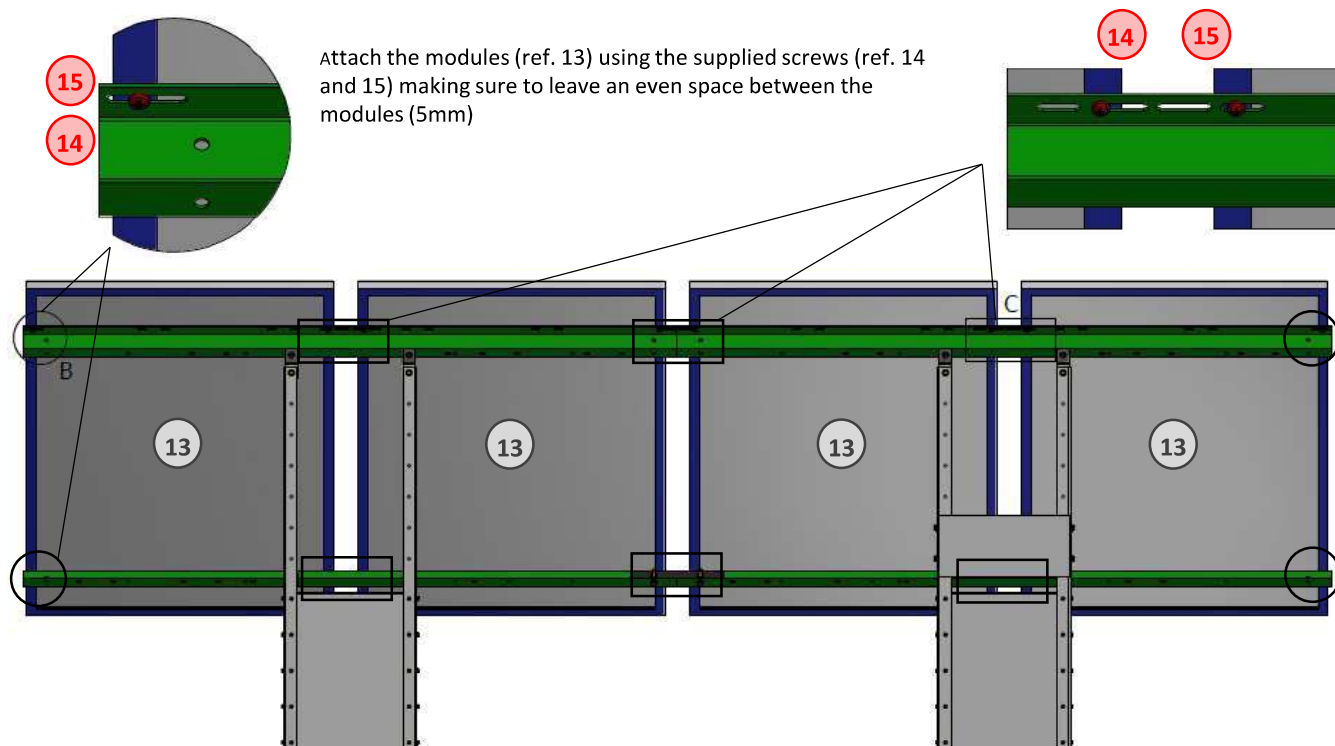

**Tip :** Place a batten inside the frame of the module when drilling to protect the glass

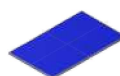

X1



X4



X4



Some frames don't allow for use of the bolt to tighten the frame.

In that case, it is recommended for example to use a stainless steel self-tapping screw 4/6 x 15mm (not supplied)

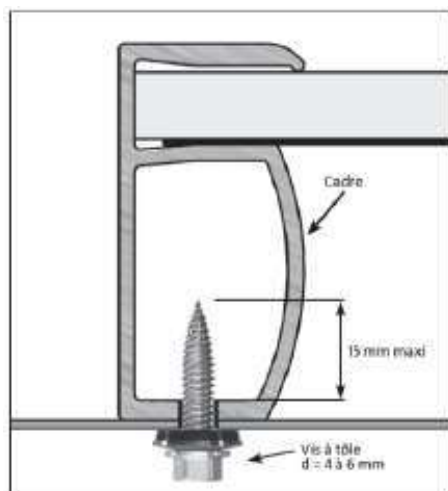

- Use this fixation method for « full » frames.
- In the case where the slotted holes don't correspond to the spacings of the ones on your modules, it's possible to drill the "Z" bar after having drilled the holes when positioning the module

# Ground System Installation

## ON ROOF RAIL ASSEMBLY – OPTION 2

It is possible to change the Z bar (ref 6) with the On Roof System rail.

Mark the location of the bracket holes on the rail. Then place the rail above the brackets and drill a  $\varnothing 8\text{mm}$  hole in the rail at each bracket holes using the drill guide.

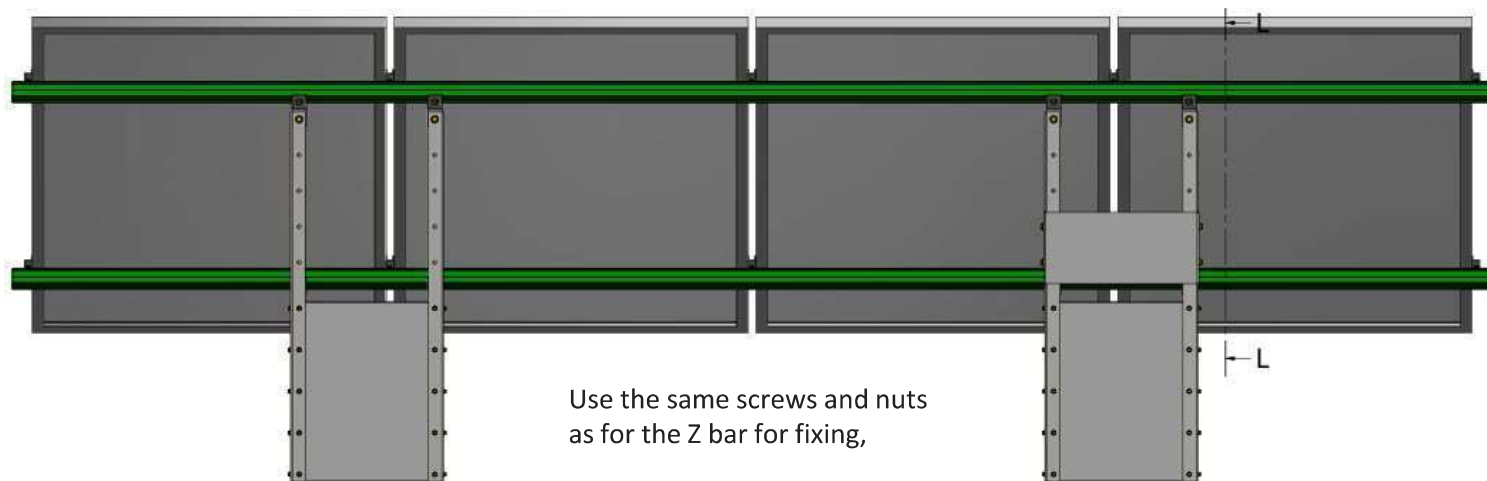

Use the same screws and nuts as for the Z bar for fixing,

N (1:2)

X1

X4

X4

M (1:2)

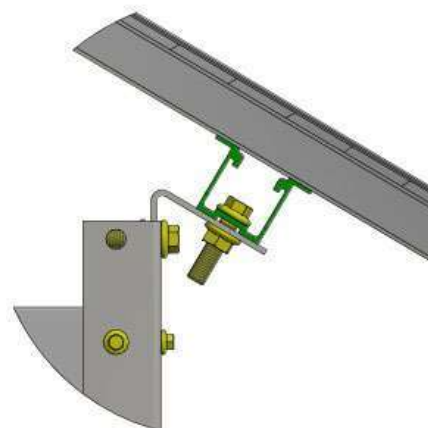
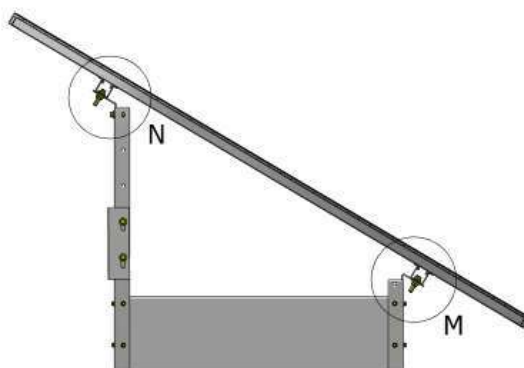
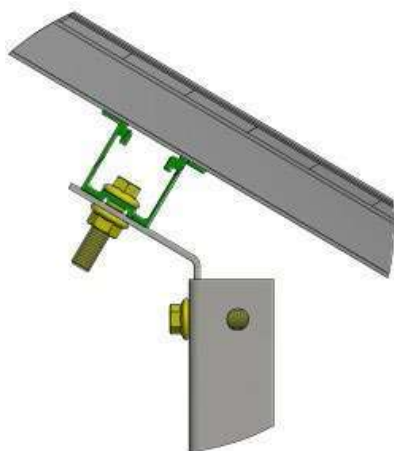

Number of module	Module sizes														
	808			992			1001			1016			1046		
	Rail (m)	Cutting (mm)	Overflow (mm)	Rail (m)	Cutting (mm)	Overflow (mm)	Rail (m)	Cutting (mm)	Overflow (mm)	Rail (m)	Cutting (mm)	Overflow (mm)	Rail (m)	Cutting (mm)	Overflow (mm)
2	2,1	364	50	2,1	/	48	2,1	/	40	3,15	998	50	3,15	968	50
4	4,15	758	50	4,15	/	61	4,15	/	43	5,17	946	50	5,17	826	50
6	5,17	/	111	6,2	/	74	6,2	/	47	2 x 3,15*	/	52	2 x 4,15*	824	50

\* For the assembly of 2 rails please refer to the installation instructions of the On Roof System

# Ground System Installation

## ■ ATTACH THE MODULES - OPTION 2

Fix the modules (REF.13) using the clamps. Here no need to drill the modules, the clamps are fixed directly on the rails

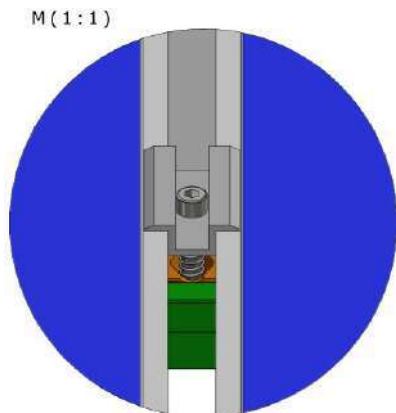
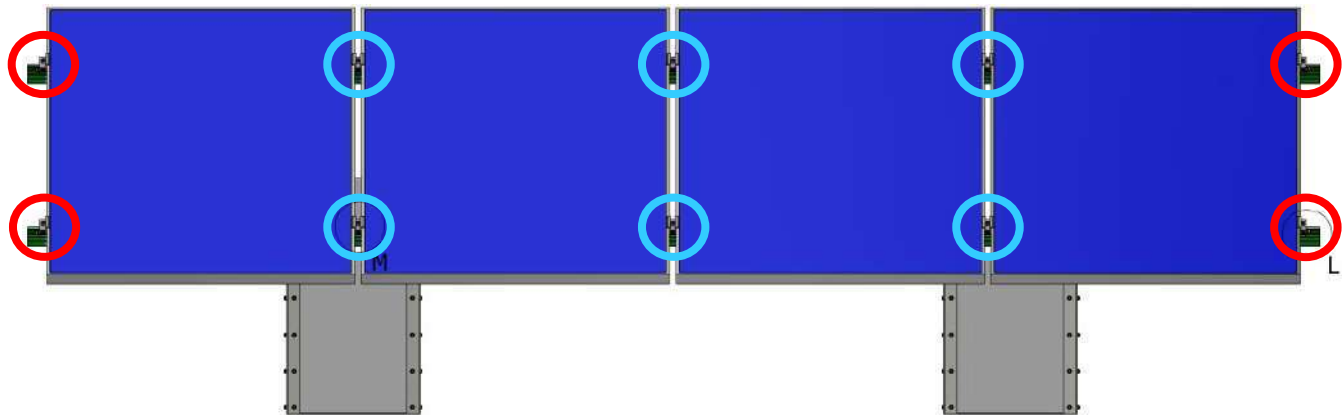

● SIMPLE CLAMP  
(EDGE OF FIELD)



● DOUBLE CLAMP  
(BETWEEN 2 PANELS)

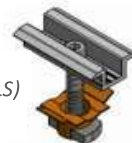

L (1:1)

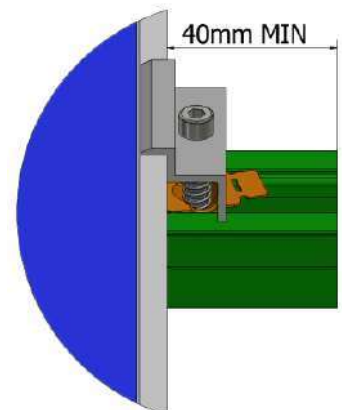

**Clamp tightening : 240dN**



Minimum rail clearance overflow to module : 40 mm

Clamps mounting :

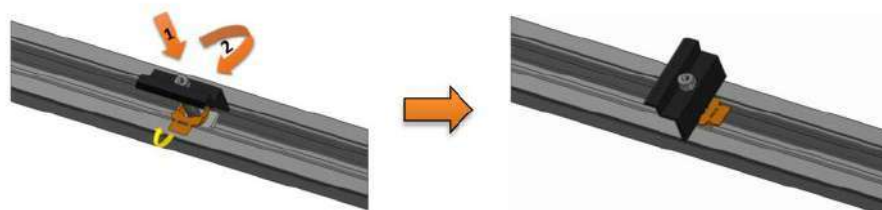

# Ground System Installation

## POSITIONING OF THE MICRO-INVERTERS

Slotted holes are available if needed for placing micro-inverters or optimizers (fixing screws not supplied > 9x30mm).

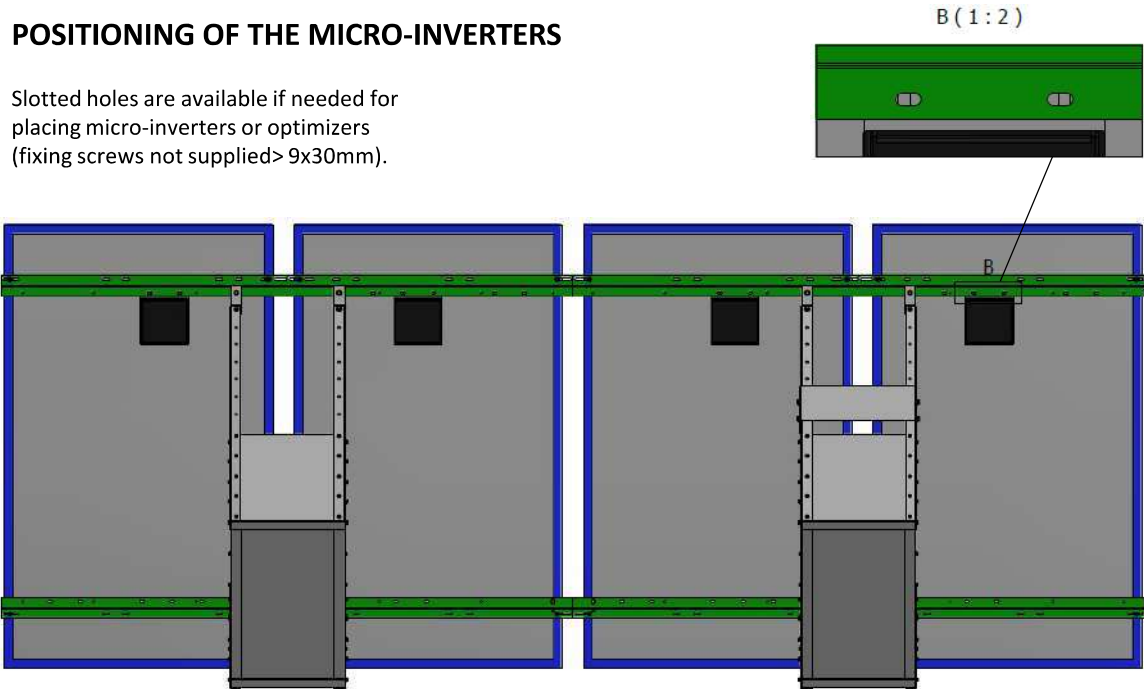

## FASTENING THE PROTECTION BOXES AT THE BACK OF THE SYSTEM (OPTIONAL)

A plate dedicated to the fixing of the protection boxes is available as an option. Be careful with their IP protection !

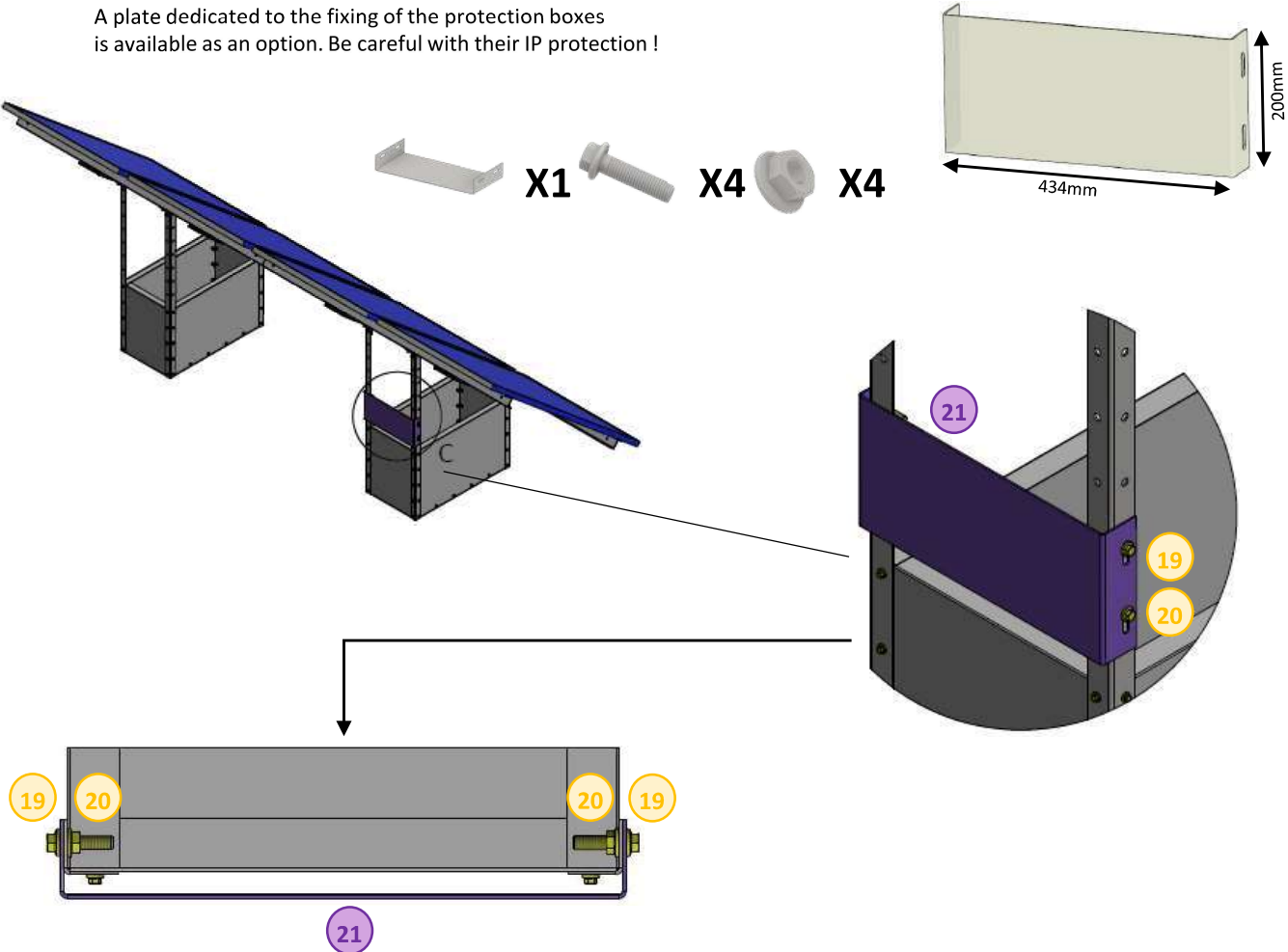

# Ground System Installation

## ■ SYTEME BALLASTING

Ballast the structure with the most adapted solution for your installation.

The ballasting needs to be adjusted according to the inclination of the modules and the climate exposure of the installation (cf. wind rules NV65)  
By default, with a standard 40° inclination, a ballasting of 480Kg is recommended (=120Kg per module)

**Examples of possible ballasting :** Volume of the box 0.15 m<sup>3</sup>

- **Concrete Slab** of 400x400x37mm (12.8Kg)  
Possibility to put 20 slabs per box, i.e 256Kg per box, hence = 512 Kg Total
- **Dry Sand** : 1m<sup>3</sup>  
of dry sand = 1800Kg  
Possibility to insert 150L of sand per box, i.e 270Kg per box = 540Kg Total
- **Gravels 4/20** : 1450Kg/m<sup>3</sup>  
Possibility to fill the boxes with 217.5Kg of gravel, i.e 435Kg Total



In case of important wind gusts, it's recommended to fix the system to the ground using the adapted fixations at the bottom of the boxes. An average of 120Kg per module is enough.

## ■ ELECTRICAL CONNECTION

You can now implement the electrical part of the installation.

- Connect the structure to the earth.
- You can attach your micro inverters on the frame of the structure
- Please respect all security recommendations regarding cables burying
- Please also respect the electric norms of the electric guide UTE C15-712-1

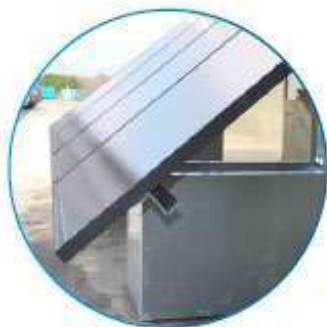



# Implementation advice

## ■ OPTIMIZING THE SPACE OF THE GROUND SYSTEM

In order to optimize the space occupied and the performances of the GSE GROUND SYSTEM, they should be placed in a way that they don't create a shadow zone on one another.

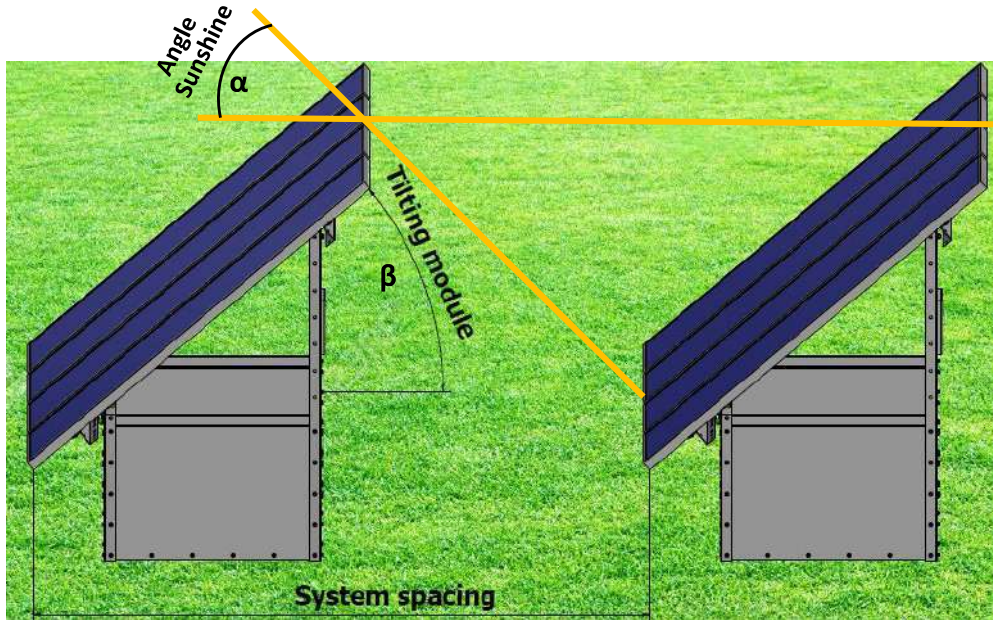

*GROUND SYSTEM layout diagram*

It is thus possible to deduce the spacing between the systems according to the following formula :

$$D = L \times (\sin(\beta) \times \tan(90 - \alpha) + \cos(\beta))$$

- **D** = Spacing
- **L** = Length of the long side of the associated module
- **α** = Angle of solar radiation (°)
- **β** = Tilt angle of the modules (°)

Angle sunshine per city :

City	Amsterdam	Lille	Paris	Strasbourg	Nantes	Lyon	Bordeaux	Marseille	Madrid	Marrakech	Dakar
α (°)	37,6	39,4	41	41,4	42,8	44,3	45,2	46,7	49,6	58,4	75,3

Example :  $D = 1675 \times (\sin(19^\circ) \times \tan(90 - 15) + \cos(19^\circ)) = 3700\text{mm}$

For a 1675x1001x40mm module, the following spacing values are obtained

α (°) \ β (°)	19	25	30	35	40
15	3700	4200	4600	5000	5400
30	2600	2800	3000	3100	3200
45	2200	2300	2300	2400	2400
70	1800	1800	1800	1800	1700

Spacing in mm systems for a 1675mm length module

# Example of system adaptation

## ■ SYSTEM ADAPTATION FOR PANELS 1200x600mm

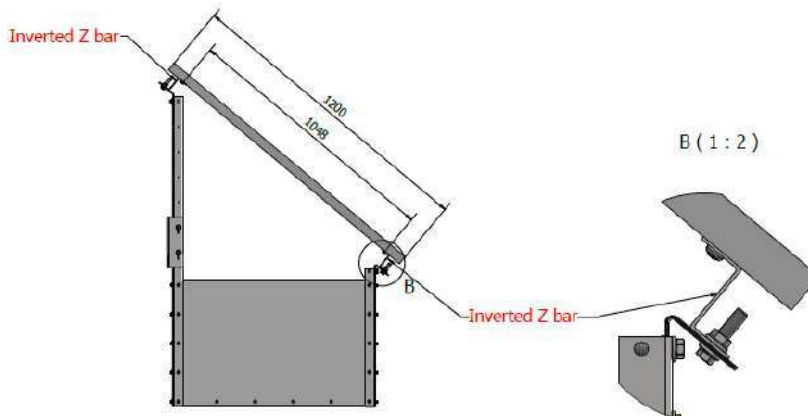
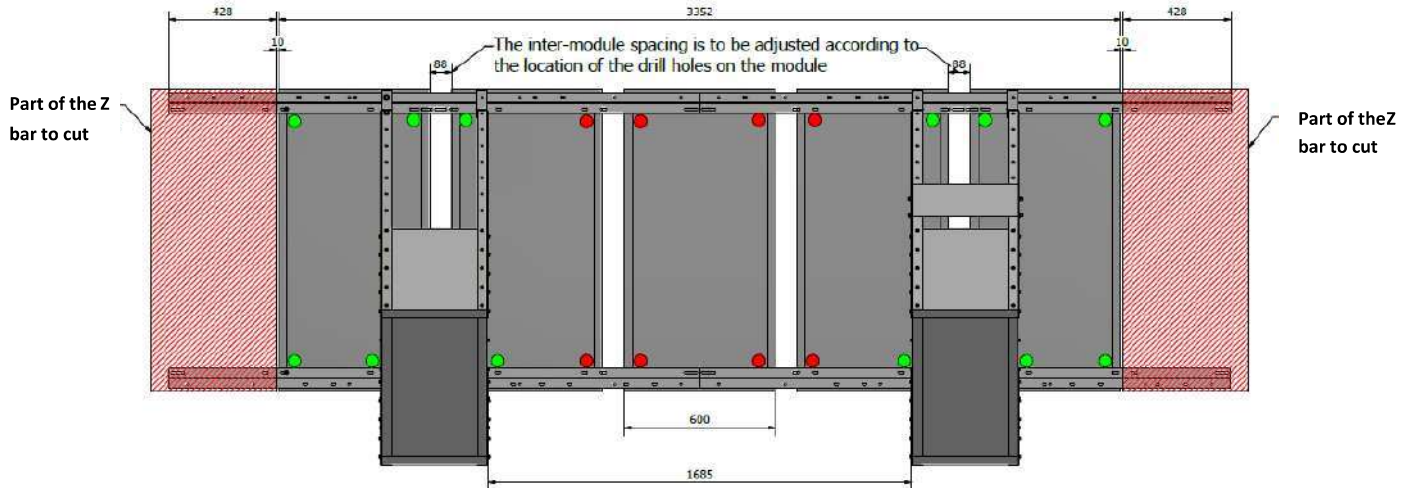

For any specific request, you can contact the design office at :  
01/49/48/14/49 ou by mail at : [eng.segroup@gmail.com](mailto:eng.segroup@gmail.com)

The thickness of some of the profiles of galvanized steel like the angles (> 2mm) requires spraying after the installation of a layer of a galvanizing spray can to finish the galvanic bridge. The spray can provided, will protect the edges of your profiles before or after installation.

