

Please read these instructions completely before beginning installation.

**KIT CONTENTS**

QTY.	DESCRIPTION
2	Brackets: Anodized aluminum mounting brackets
4	Backing plates: Steel backing plates, threaded M6x1.0
2	Rubber damping pads for mounting brackets, 70A durometer, preapplied adhesive
4	Rubber damping pads for backing plates, 70A durometer, preapplied adhesive
8	Screws: M6x1.5 x 14 mm steel button head hex drive

**IMPORTANT**

Allow vehicle to cool completely before attempting installation or maintenance of oiling system components.

**Summary**

These brackets assist in the mounting and protection of the oil cooler; however, mounting an oil cooler with these brackets is no guarantee of protection or substitute for common sense.

- Plan installation to secure the mounting hardware to chassis points that will isolate the oil cooler from chassis flex/torsion.
- Ensure that oil lines have been secured as closely as possible to their entry & exit on the oil cooler.

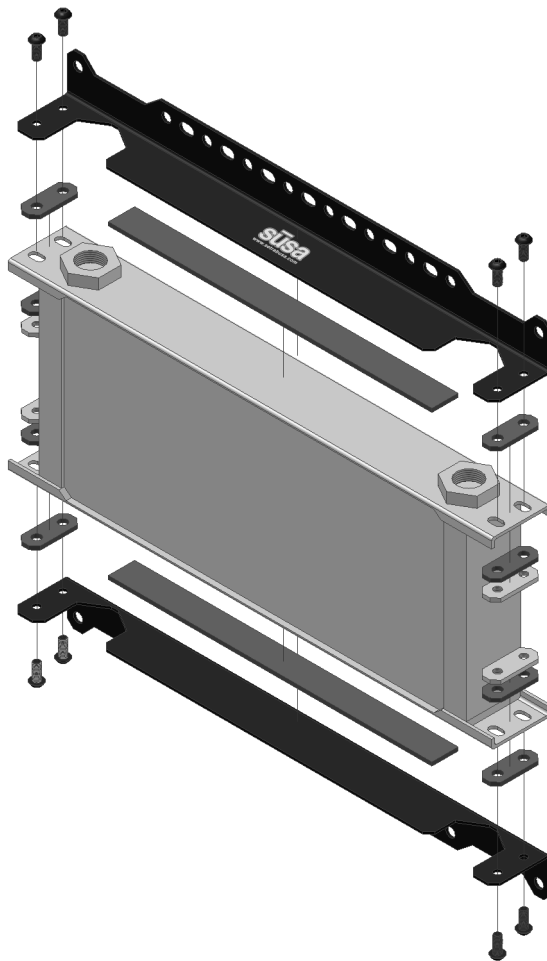

23-1002  
susa ProLine STD1 Mount Kit  
Mfr. P/N: 23-1002

**Warning:** Installation should only be attempted by those with mechanical skills and experience working on vehicles. Standard safety precautions consistent with the tools and dangers of automotive work should be followed to protect from injury. Specifically, wear protective equipment, take care to stabilize the vehicle on a level surface, engage the parking brake, and allow vehicle to cool before attemptation installation; failure to comply can result in injury and/or damage to equipment.

## INSTALLATION

### Installing rubber backing damping pads:

1. Peel away the rubber damping pads' wax-paper backing and affix pads to mounting brackets and threaded backing plates.

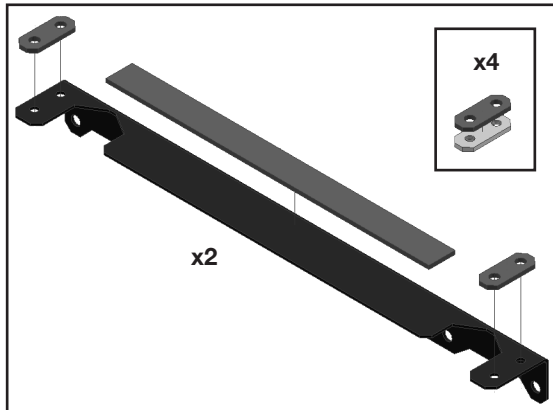

### Installing mounting brackets to oil cooler:

2. Place mounting bracket on top of oil cooler with damping pads facing oil cooler top plate.
3. Place steel back plates under oil cooler mounting tabs with rubber damping pads toward mounting bracket.
4. Use included M6x1.0 x 14 mm button head hex drive screws to fasten mounting bracket to oil cooler mounting tabs.  
**NOTE:** Application of a medium-strength threadlocker compound is recommended for a more secure and durable screw installation.
5. Tighten screws, compressing bracket's rubber damping pads by no more than 50%. Rubber should *not* squeeze out.  
**NOTE:** Over-compression of rubber damping will reduce its effectiveness at absorbing vibration.
6. Repeat steps 1–4 to install remaining mounting bracket.

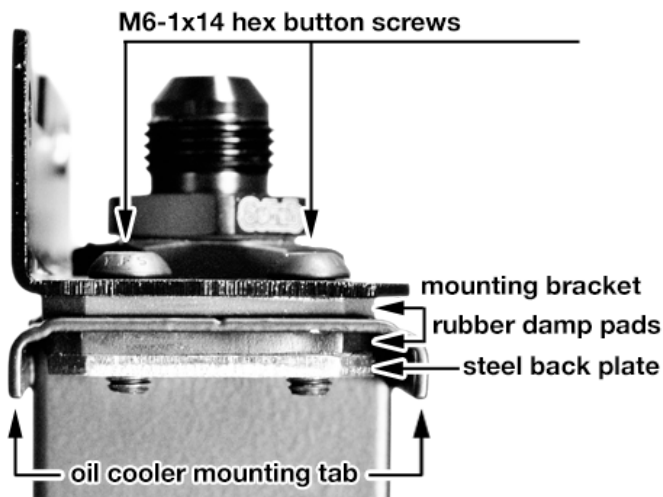

### Installing oil cooler assembly onto vehicle:

7. Plan mounting location to chassis points that will isolate the oil cooler assembly from chassis flex and torsion. Torsion across the oil cooler body will weaken and fail the unit.
8. Fasten assembly to vehicle utilizing both mounting brackets, and distribute the mounting points across the brackets evenly.

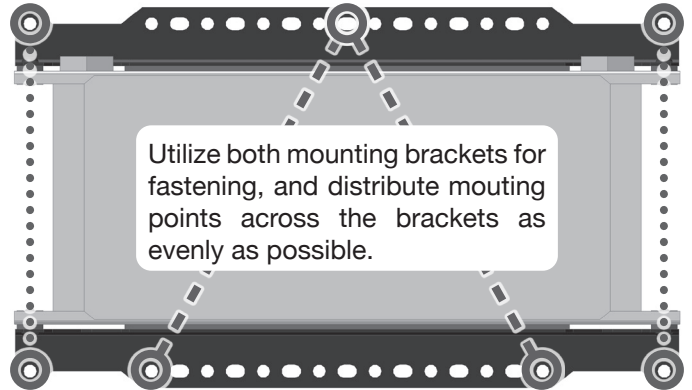

**Warning:** Installation should only be attempted by those with mechanical skills and experience working on vehicles. Standard safety precautions consistent with the tools and dangers of automotive work should be followed to protect from injury. Specifically, wear protective equipment, take care to stabilize the vehicle on a level surface, engage the parking brake, and allow vehicle to cool before attemptation installation; failure to comply can result in injury and/or damage to equipment.