

# FLYCAM DSLR Nano Blue Handheld Camera Stabilizer (DSL-NANO-QR-BL)

## Assembly Manual



### ■ What's In The Box

Please inspect the contents of your shipped package to ensure you have received everything that is listed below.

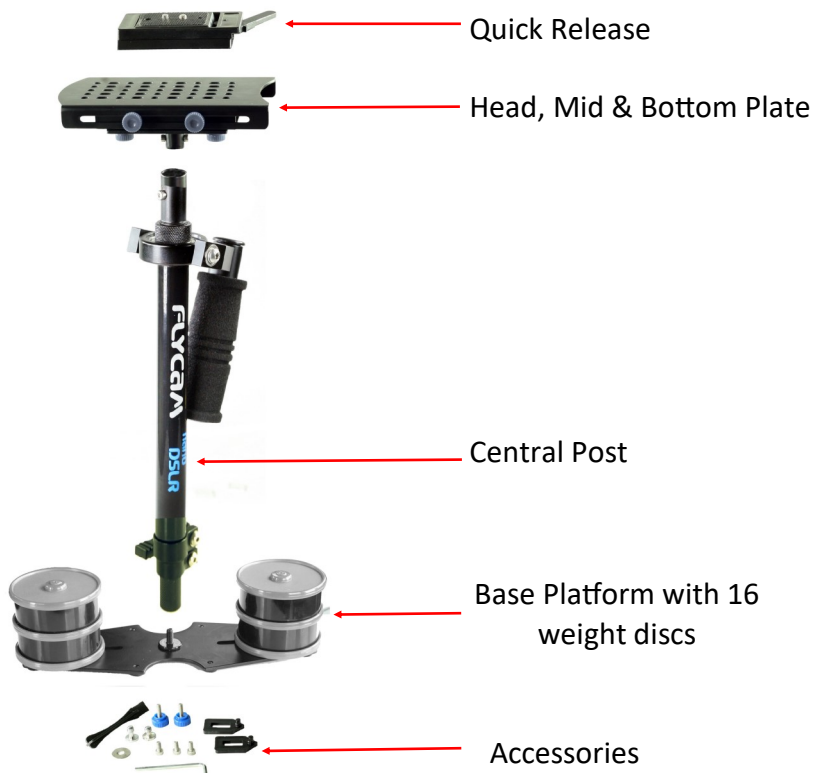

All rights reserved.

No part of this document may be reproduced, stored in a retrieval system, or transmitted by any form or by any means, electronic, mechanical, photo-copying, recording, or otherwise, except as may be expressly permitted by the applicable copyright statutes or in writing by the Publisher.

## HEAD ASSEMBLY

- Head Plate
- Mid Plate
- Bottom Plate
- These three individual pieces are shipped as one assembled unit.

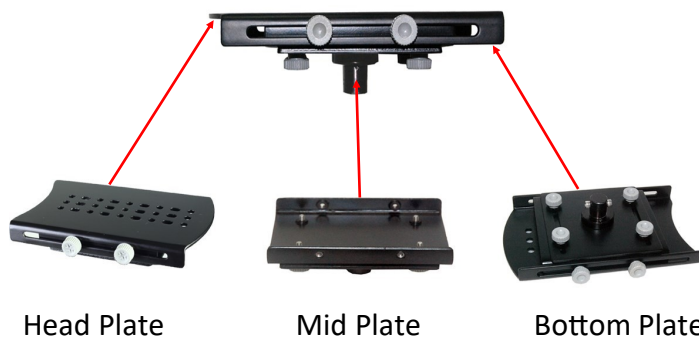

### 'V' SHAPED ADAPTORS INCLUDED IN HARDWARE KIT

**NOTE:** The hardware package includes two different-sized V-shaped adaptors used to attach the camera to the head plate. Choose any one suitable for your camera. A locking pin at the front of the adaptor prevents camera rotation on the head.



### QUICK RELEASE PLATE AND ADAPTER



**NOTE:** The threaded stud is located in the center of the base plate to attach it to the central post.



## CENTRAL POST

**Warning:** The gimbaled control unit, handle, and yoke have been factory set for optimum performance.

**Do not attempt to adjust them.**



## ASSEMBLING YOUR HANDHELD STABILIZER

- Loosen the 2x Allen bolts at the bottom of the camera plate, align the holes with the top of the central post & retighten the Allen bolts securing the head to the stalk.



- Remove the quick release plate from the adapter by sliding the release lever to the open position. Next, attach the quick release plate to the camera base.



- Remove the head plate by unscrewing the four side knobs to mount the quick-release adaptor.



- Loosen the Allen bolt at the bottom of the quick release adaptor and attach it to the head plate. Then, retighten the bolt to secure the adaptor to the plate.



- Attach the head plate to the Flycam handheld stabilizer with appropriate fore & aft positioning and tighten the side knobs as shown. Further 'fine tuning' will probably be required.



- Slide the release lever to the open position and insert the camera set up into a quick release adapter. Then, return the lever to its original locked position.



## YOUR FLYCAM HANDHELD VIDEO STABILIZER FULLY ASSEMBLED



If you do not wish to use the quick release plate, the camera can be directly attached to the Head Plate by using the following assembly sequence (without the quick release plate)

- Remove the head plate from the 3-piece head assembly in preparation to attach it to your camera. You will note many mounting holes that can adapt to various cameras.



- Center the head plate on the camera and secure it properly.

**Do not over tighten this adjustment as it can break the threaded insert.**



- Align the camera center of balance to the mid plate and secure the head plate and camera to the mid plate.



- The many slots on the head and bottom plates allow you to adjust the X & Y axis for perfect balance easily. Once achieved, tighten the knobs to secure. Further 'fine tuning' will probably be required..



### Head Plate X adjustment

### Head Plate Y adjustment

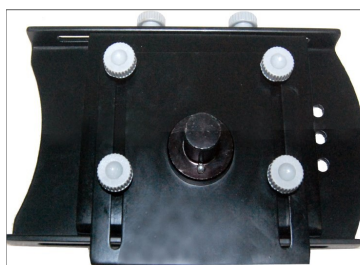

## Adding Weights & Positioning for Proper Balance

Continuing the assembly and balance requirements to make your FLYCAM DSLR Nano fully functional, you will note that the base platform has a provision to mount the balance weights in their cups via a slot found on both sides of the post.

The counterweight system's purpose is to match the low end of the stabilizer to the weight of the camera and accessories at the high/top end with gimbaled handle as the pivot point in between. The heavier the camera and accessories, the more weight is required to achieve proper balance. Generally, as you add weight to one side of the central post, an equal amount must be added to the other to maintain horizontal balance. However, suppose you are using an offset configuration such as a flip-out viewfinder or off-center accessories. In that case, extra weights might be needed on the opposite side of the post to counteract and maintain proper balance.

The total weight fixed to the base platform should equal the weight of your camera plus the head and accessories.

**Horizontal adjustment** on the base platform is made by loosening the retaining screws, moving the mounted cups closer to or further away from the stalk, and then re-tightening. You will probably need to adjust and re-adjust the horizontal position to achieve optimum performance/personal preference.



**NOTE:** When adding weight to the cups, use the supplied foam spacers as silencers to prevent metal-to-metal washer noise.



## VERTICAL STALK ADJUSTMENT

**Vertical Adjustment** of the telescopic central post is made by loosening the control at the base, raising or lowering the post to the desired location, and then re-tightening the vertical control. Do not over-tighten this control.

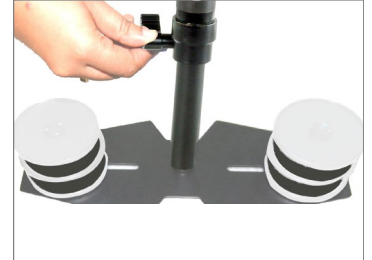

## ■ Balancing Your Flycam Stabilizer

Before beginning the balancing process check the following:

- Camera is securely attached to Head Plate
- Lens cap is removed and secured
- Telescoping Clamp is tightened
- Weight discs are added successfully
- All screws are tightened securely
- Battery, all accessories and cables are secured

## Balancing the Horizontal Axis

When your FLYCAM DSLR Nano is properly assembled, you can start the test and setup of the horizontal balance. Horizontal balance allows the camera to remain level during operation with the Central Post in a vertical position unless off-axis framing is desired. Testing for horizontal balance starts from a flat and level surface like a table, allowing the FLYCAM DSLR Nano to hang free as you hold it. If your FLYCAM DSLR Nano is correctly balanced on its horizontal axis, then it will be both level & upright, with the Central Post in a perfectly vertical position.

**Warning:** If you do not have enough weight on the Base Platform, the entire Flycam could flip upside down. If this movement starts to happen, be ready to catch the stalk before a complete 180 occurs. This type of unwanted movement requires more weight to be added to the base with additional weight discs.

Another way to accomplish Horizontal Balance is to move the center of gravity of camera by re-mounting the camera to a different area of the Head and Mid Plate, either front-to-back or side-to-side.

If the FLYCAM DSLR Nano is front heavy, loosen the screws on the sides of the Head Plate and gently slide the Head Plate back until the optimum balance is achieved. Tilting to the back means the load is tail heavy requiring the plate to be adjusted forward on the head.

### **Always secure the screws after any adjustments.**

If you cannot achieve front to back axis balance with this method, then try remounting your camera to a different hole on the Head Plate. Having achieved horizontal balance for the front to back axis, tighten the screws on the Head Plate.

If the FLYCAM DSLR Nano leans to the right, then loosen the screws on the bottom of the Bottom Plate and then gently slide the Mid Plate to the left. If it leans to the left from the operator's point of view, then adjust the Mid Plate to the right. A bit at a time until balance is achieved.

### **Secure all parts after adjustments are made.**

It may be necessary to reconfigure front to back adjustments once correct side-to-side fine-tuning has been accomplished.

Another option to consider is moving the Counter Weight cups back & forth on the Base Platform by sliding them either closer to or further away from the Center Post via the built in base slots. Make sure to tighten the cups down should you move them.

## **Balancing the Vertical Axis**

The sled should be tied up to the docking adapter of your stand or similar so that you can start the fore & aft balancing adjustments by centering the camcorder over the central post. To do this

- Loosen the side screws of Head Plate and the bottom screws of Bottom Plate. Look at the stabilizer from side. If the camcorder lens is tipped up or down, move the camcorder forward or backward
- until the center of balance is situated over Central Post.
- Then, look at the stabilizer from front. If the post is not vertical, adjust the bottom plate until Central Post is vertical.
- You can also adjust the weight cups closer to & farther away from the sled as per requirement, till the post is straight up and down.
- The stability of Flycam Stabilizer depends on it being slightly bottom heavy. If it is top heavy, it will tilt more. If it is too bottom heavy, it will be sluggish and hard to aim.

**Slightly Bottom Heavy, it will be both Stable and Easier to Control.**

**Check the Vertical Balance by using this Drop Time Test.**

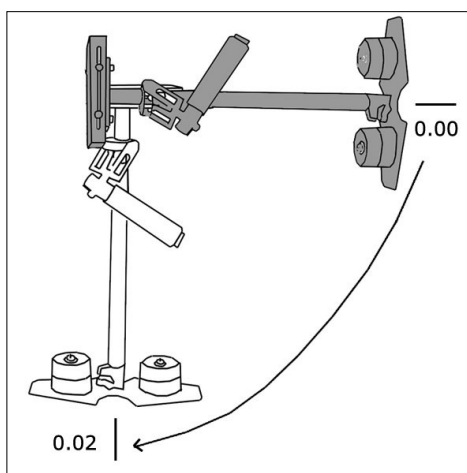

- Make sure that everything is tight and position yourself behind the stand.

- Grasp the center post near the base and move the center post from vertical to horizontal.
- Hold it there. Be sure that it will not hit the stand when you drop the center post and put your free hand to catch the center post when it drops.
- Count how many seconds it will take to fall to vertical. Try using a stopwatch.
- If the drop time is less than 2 seconds, it is too bottom heavy. You need to move the bottom mass closer to the post.

**A DROP TIME OF 2 - 2.5 SECONDS IS PREFERRED.**

**NOTE:** Recheck the balance by looking at sled. If necessary, use side screws and bottom plate screws to make required adjustments.

## Balancing Review

- Proper system balance can only be accomplished once your camera has been set up with the necessary accessories and is ready to shoot. It includes batteries, lenses, media cards, an LCD viewfinder/monitor, a fast-release plate, on-camera lighting, and all the other equipment you'll need for your recording session.
- Remove top plate of stabilizer and line-up your camera so that its center of gravity is as close to the center of plate as possible (basically hold the camera in your hand until it feels balanced both left and right as well as forward and backward).
- Find the hole in the plate closest to your camera's threaded tripod attachment (while keeping your camera's center of gravity to the center of the plate). Attach your camera (or quick release mount if you have one). Tighten it up so it doesn't rotate accidentally.
- Re-attach the top plate to the Flycam. Center it, but don't worry about getting it absolutely perfect yet.
- Remove most of the weights from the Base Platform, but leave one on each side.
- Insert the center post as far as it will go and tighten so it won't slide out.
- Hold the handle normally and turn the FLYCAM DSLR Nano so that it is horizontal to the ground. Let go of the stalk while keeping a firm grip on the handle and count how long it takes to return to vertical again. You should be able to count a good, "One-one thousand, two-one thousand", before it rights itself. With only two little weights it might take considerably longer.
- Add one pair of weights at a time and repeat the "horizontal to vertical" test until it falls at the correct rate. It will probably not be perfect.



- You'll get one that's too slow and then you'll add a pair and it will fall too fast. When that happens, take off the last pair of weights that you added.
- Tighten down the weights so they don't slide around.
- To get the count perfect, slightly lower the center post that attaches the Base Platform with the weights until you get the "one-one thousand, two one thousand" count to the vertical position.
- Fine-tune the left-right, forward-backward balance. You will have to go back and forth between the two directions to get the balance just right. Loosen the screw sets that allow the sled to move left and right. Adjust the top plate so that it is centered and tighten down the screws like you would a tire slowly and alternating side to side.
- Repeat for "forward-backward" balancing.
- Check to see if your camera is sitting level. If not, repeat the necessary steps until it does.
- Practice walking/movements ensuring your body motion is not transmitted to your hands and then the Flycam and camera.

## Holding your Flycam Stabilizer

When handling your DSLR Nano one hand holds onto the handle while the other is used to gently guide the camera in the direction you wish to shoot and frame the shot.

For normal shooting, hold the handle in the middle.

For shots that require framing the camera up, down or sideways, hold the handle firmly at the bottom.

This will allow the "yoke" part of the gimbal to rotate without hitting your hand or knuckles



## Maintenance

**Bearing Maintenance:** The Main Bearing on your FLYCAM DSLR Nano is attached to the central post about two inches from the top. It is of metal construction and partially enclosed by the Bearing assembly. If after a period of time your bearings don't turn smoothly, lubricate with a minimum of light machine oil. Light lubricating oil can also be used on the Yoke and Handle Bearings. Be sure to keep oil away from your camera, & clean up any over spill.

**Cleaning:** Do not use solvents or harsh cleaners of any kind on your Flycam DSLR Nano. If the unit becomes dirty, use a damp soft cloth or sponge and a mild detergent to gently clean external parts.

**Storage:** Should you need to store your FLYCAM DSLR Nano for a long period of time then place the unit upright in a dry or low to normal humidity area whenever possible. If you are unable to find this kind of environment then we suggest you store the unit in an airtight plastic container or bag.

Standing the unit upright is preferred as it alleviates stress on the system.

**NOTE:** The FLYCAM DSLR Nano doesn't work under water, nor is it waterproof. Avoid direct exposure to rain, water spray or any other harsh environment. Also the bearings are not sand/grit proof and need to be kept free of these contaminants. Avoid getting dirt or sand in them.

## Practice Makes You Perfect - Walking the Line

Practice this simple exercise to master your FLYCAM DSLR Nano with professional results. Using masking or gaffer tape, create a cross mark on a flat and even wall. The mark becomes your framing center. On the floor leading up to the cross mark lay a straight tape line of about 20 feet. Practice walking the line while keeping the cross mark center framed and focused. With some effort, dramatic fluid movements will become second nature and provide production value to all your setups.

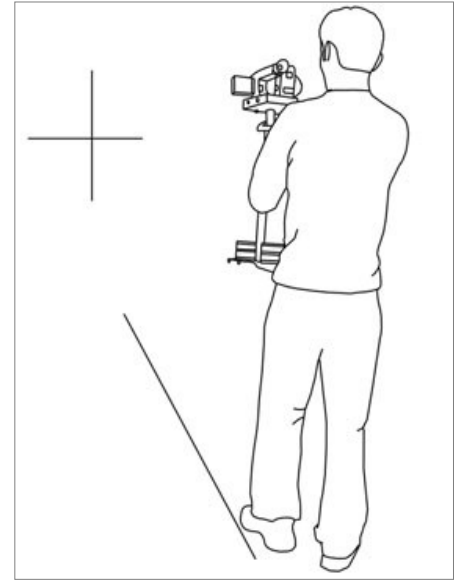

**Warranty:** We offer one year warranty for our products from date of purchase. Within this period of time, we will repair it without charge for labor or parts. Warranty doesn't cover transportation costs nor does it cover a product subjected to misuse or accidental damage. Warranty repairs are subjected to inspection and evaluation by us.

**Liability:** We are not liable for damage caused by products that we do not supply or from mishandling in transit, accident, misuse, neglect, lack of care of the product, or service by anyone other than our company.

**Contact Us:** In case of any kind of dissatisfaction, please Contact us immediately and we promise our utmost support and care until you use our product.