

ALL DIMENSIONS IN MILLIMETRES
REMOVE ALL SHARP EDGES

THIRD ANGLE PROJECTION
DO NOT SCALE DRAWING

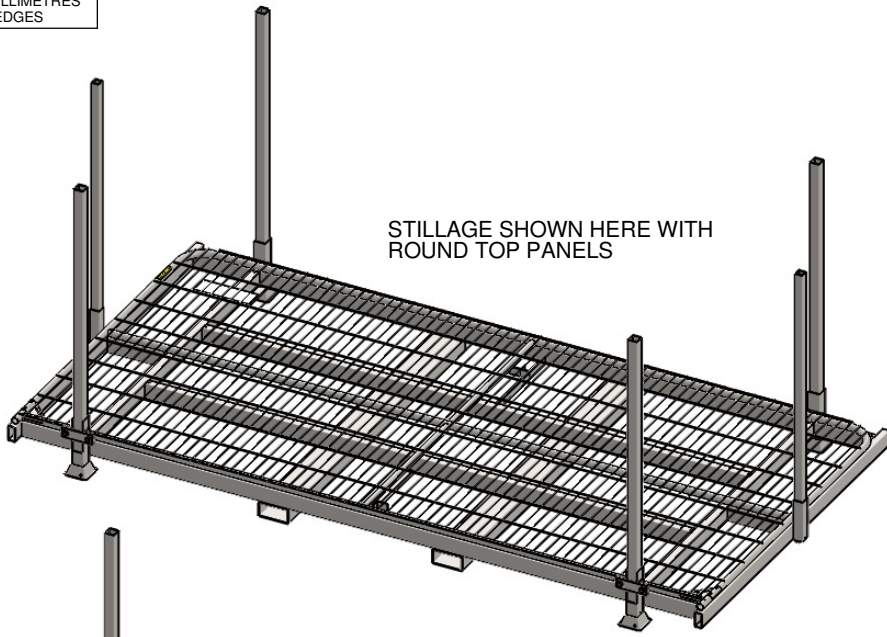

STILLAGE SHOWN HERE WITH
ROUND TOP PANELS

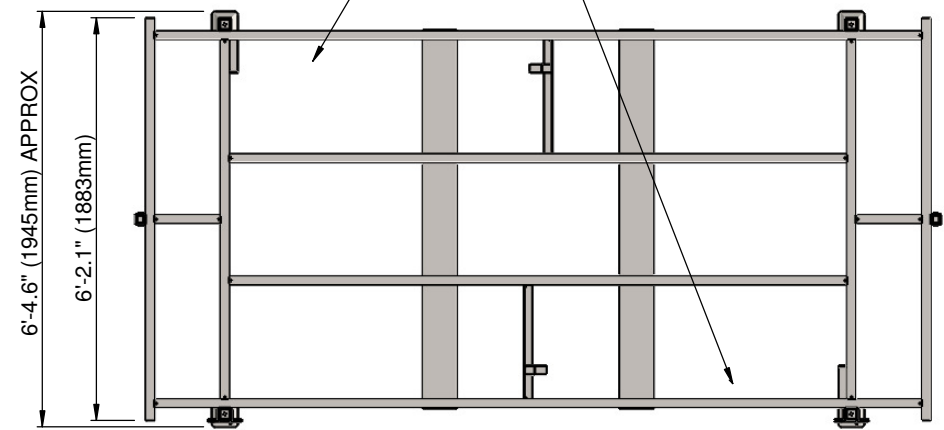

LEGS SHOWN HERE FOR STORAGE
OR TRANSPORT WHEN STILLAGE
IS NOT IN USE.

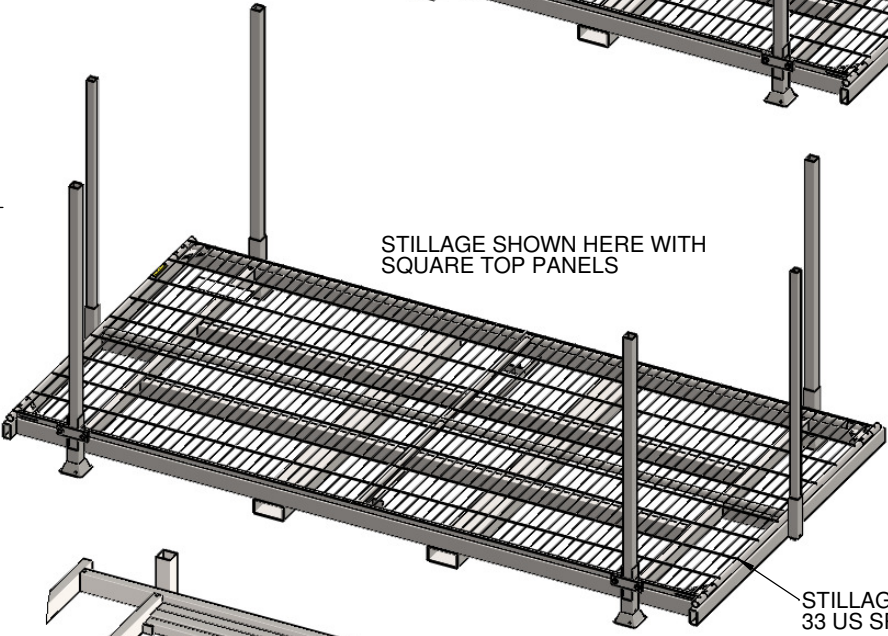

STILLAGE SHOWN HERE WITH
SQUARE TOP PANELS

STILLAGE CAN HOLD UP TO
33 US SPECIFICATION PANELS

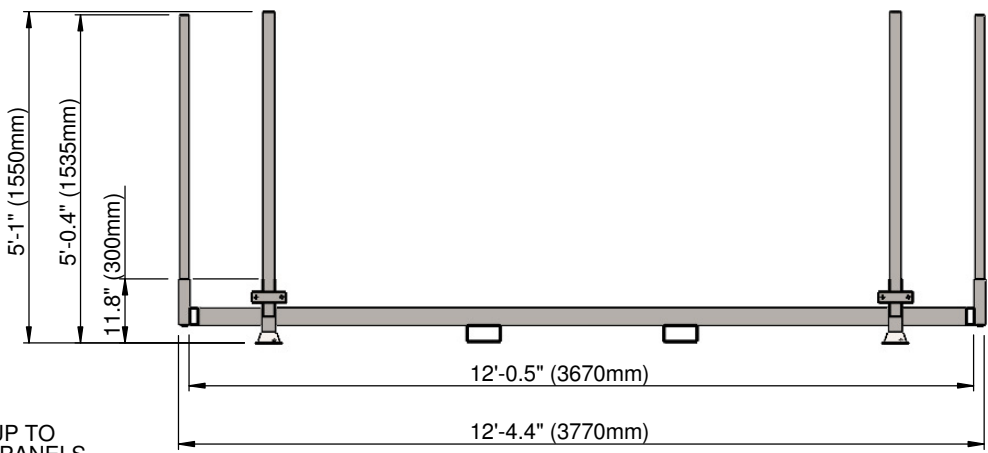

WEIGHT NOTE:
WEIGHT BEFORE GALVANIZING = 496lbs (225Kg)
WEIGHT GALVANIZED = 527lbs (239Kg) ASSUMING 6% ADDED.

7	25/11/20	ISSUED FOR MANUFACTURE	GC	.	.
5	25/9/20	ISSUED FOR MANUFACTURE	GC	.	.
REV	DATE	DESCRIPTION	DRN	CHKD	APPR

CORNER OF STILLAGE SHOWN
FLATPACK WITH 2 x LONG LEGS
AND 1 x SHORT LEG IN POSITION
FOR STORAGE OR TRANSPORT.
THIS IS THE SAME FOR THE
OPPOSITE CORNER.

TOLERANCES - UNLESS STATED OTHERWISE		
FABRICATION	UP TO 300mm	+/- 1mm
	UP TO 1000mm	+/- 2mm
	1001mm & ABOVE	+/- 3mm
MACHINING	ANGULAR	+/- 1°
	GUAGE	+/- 10%
WEIGHT	+/- 10% (DUE TO MATERIAL PROPERTIES & TOLERANCES)	

TITLE: UNIVERSAL FENCE PANEL STILLAGE 6ft			
NAME	SIGNATURE	DATE	MATERIAL:
G. CRICK		12/3/20	CARBON STEEL GRADE S235
DRAWN	CHK'D		FINISH:
			HOT DIPPED GALVANIZED



Drw / Stockcode No.	Revision
09055501 - GA	7

THE COMPANY RETAIN THE RIGHT TO PERIODICALLY ALTER INFORMATION WITHIN THIS DRAWING SHEET AND WILL ATTEMPT TO NOTIFY ALL PARTIES CONCERNED OF ANY CHANGES AND THE INFORMATION ON THIS SHEET SHOULD NOT BE REPRODUCED WITHOUT THEIR WRITTEN CONSENT.