

ALL DIMENSIONS IN MILLIMETRES
REMOVE ALL SHARP EDGES

THIRD ANGLE PROJECTION
DO NOT SCALE DRAWING

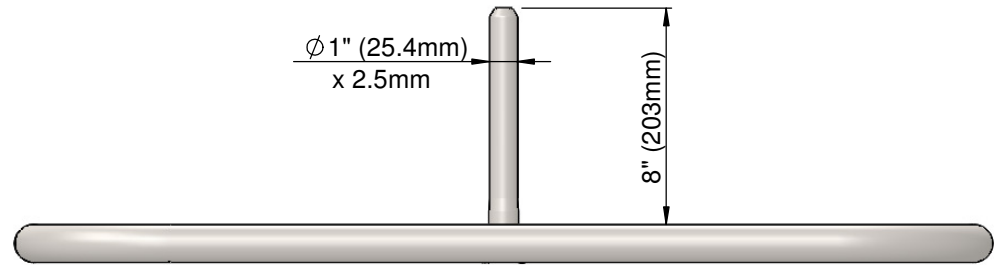
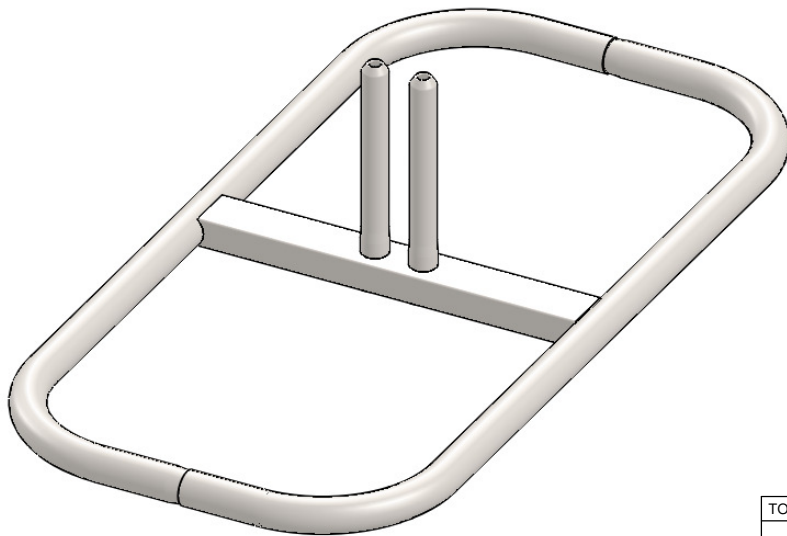
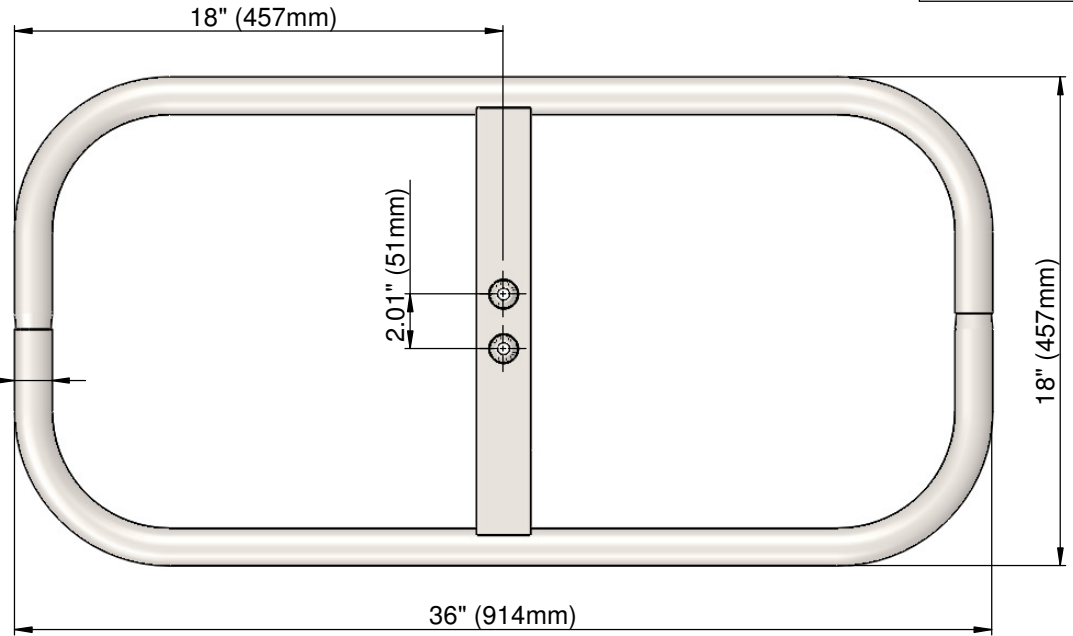

7	18/8/22	ISSUED FOR MANUFACTURE	GC		
6	20/10/21	ISSUED FOR MANUFACTURE	GC		
REV	DATE	DESCRIPTION	DRN	CHKD	APPR

TOLERANCES - UNLESS STATED OTHERWISE		
FABRICATION	UP TO 300mm	+/- 1mm
	UP TO 1000mm	+/- 2mm
	1001mm & ABOVE	+/- 3mm
	ANGULAR	+/- 1°
MACHINING	+/- 0.2mm	
TUBE GAUGE	T<1.5 = +/- 0.15mm	
	T>1.5 = +/- 0.1T or +/- 0.35mm	
	WHICHEVER IS THE SMALLER	
SHEET GAUGE	+/- 10%	
WEIGHT	+/- 10% (DUE TO MATERIAL PROPERTIES & TOLERANCES)	

TITLE: TUBE STAND			
NAME	SIGNATURE	DATE	MATERIAL:
G. CRICK		13/12/19	CARBON STEEL GRADE S235 PRE-GALVANISED
CHK'D			
FINISH:	NONE		
WEIGHT: 10.1 lbs (4.6 Kg)			

Barrier HQ

Rev / Stockcode No. **13001001** Revision **7**

THE COMPANY RETAIN THE RIGHT TO PERIODICALLY ALTER INFORMATION WITHIN THIS DRAWING SHEET AND WILL ATTEMPT TO NOTIFY ALL PARTIES CONCERNED OF ANY CHANGES AND THE INFORMATION ON THIS SHEET SHOULD NOT BE REPRODUCED WITHOUT THEIR WRITTEN CONSENT.