

# BRUTALIST CIVIC CENTRE INSTRUCTIONS

Each MDF sheet has an engraving which corresponds to the building.

## CONSTRUCTION TIPS

Paint MDF before assembly  
- paint will not look good on the fadelight plastic. You can use a wash to add definition to fadelight.

PVA Glue is the best glue for MDF - assume glue is used except for fadelight, and where this symbol is shown



Any clouding on fadelight can be easily removed with a cloth or your fingernail.

If you have any questions the quickest way I can respond is via the chat at [brutalcities.com](https://brutalcities.com)

**D**



**A**



**C**



**B**





Make sure to paint before assembly!

Glue the columns to the slab as shown



Before the next steps make sure you Line up plates so the holes match

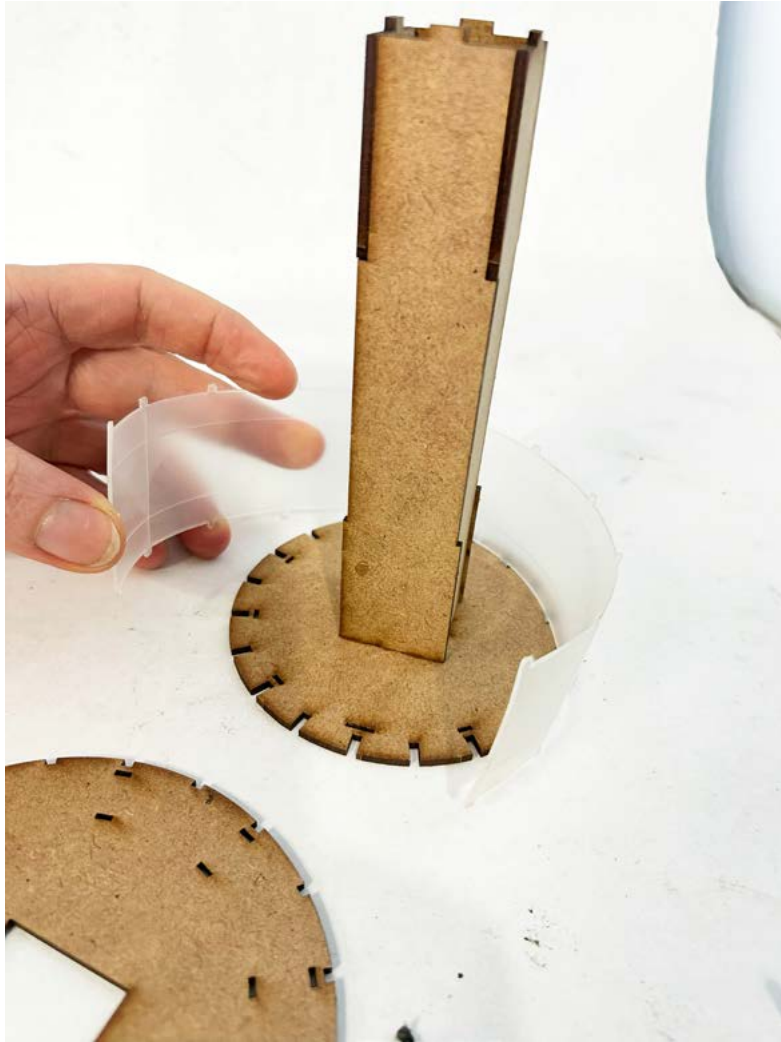

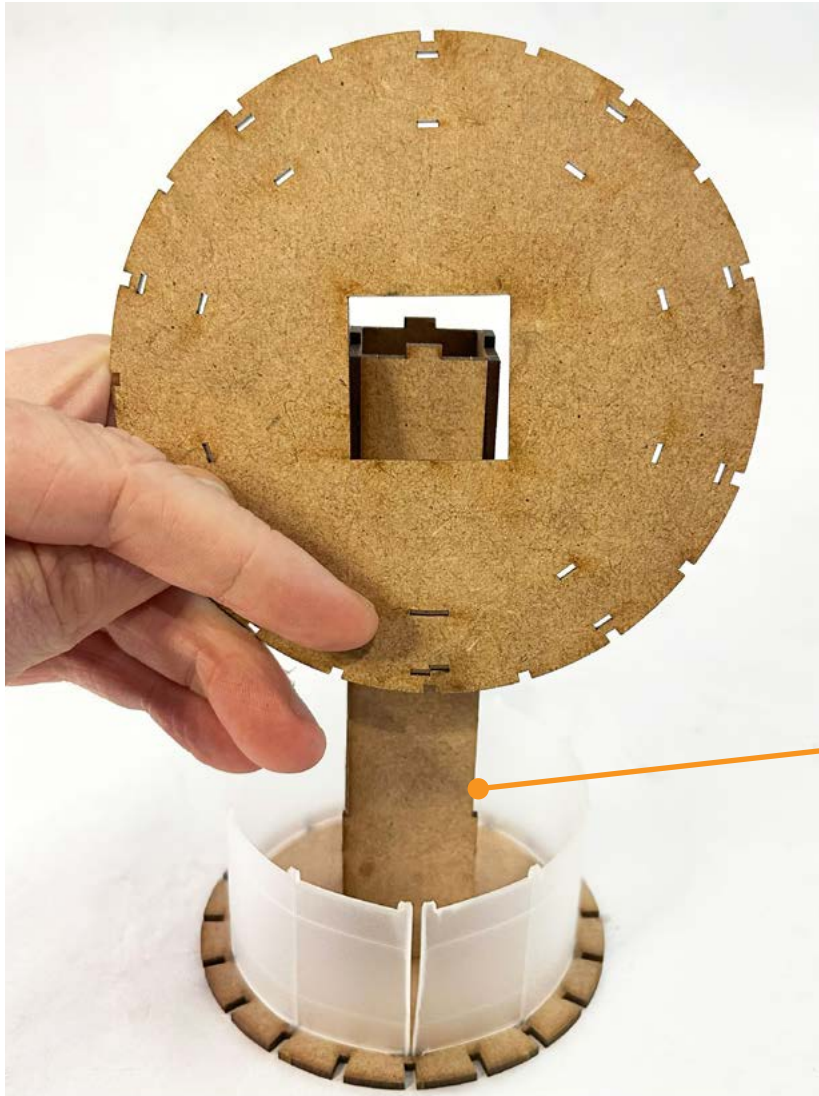

Glue the slab  
to the core



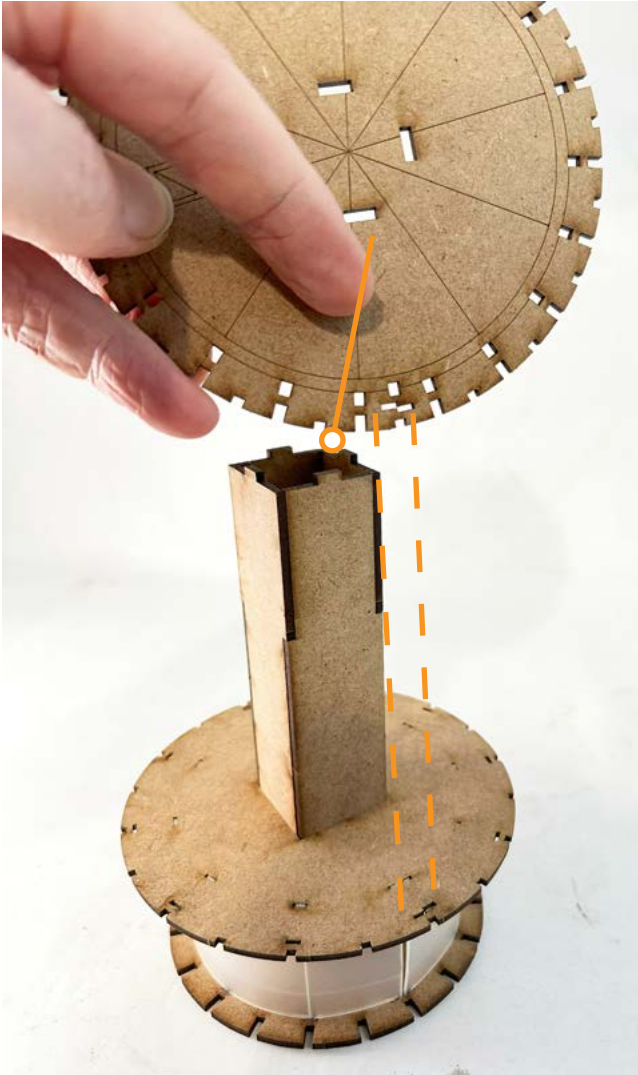

Pay attention to alignment so the fadelight plastic slots line up.

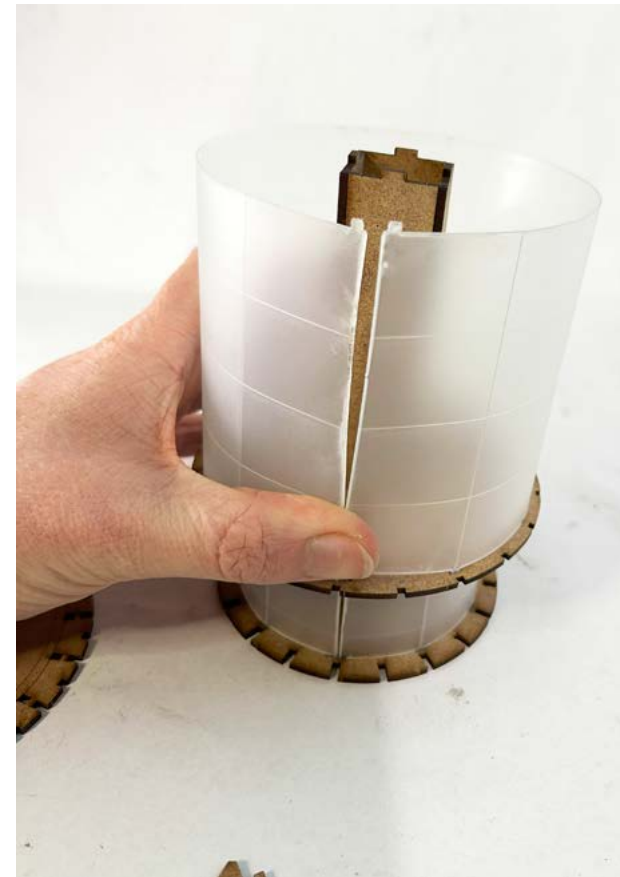

Slot the fadelight into the holes on the slab.

This part can be a bit tricky. Use rubber bands if it's curving too much.

Glue the roof slab to the central core.



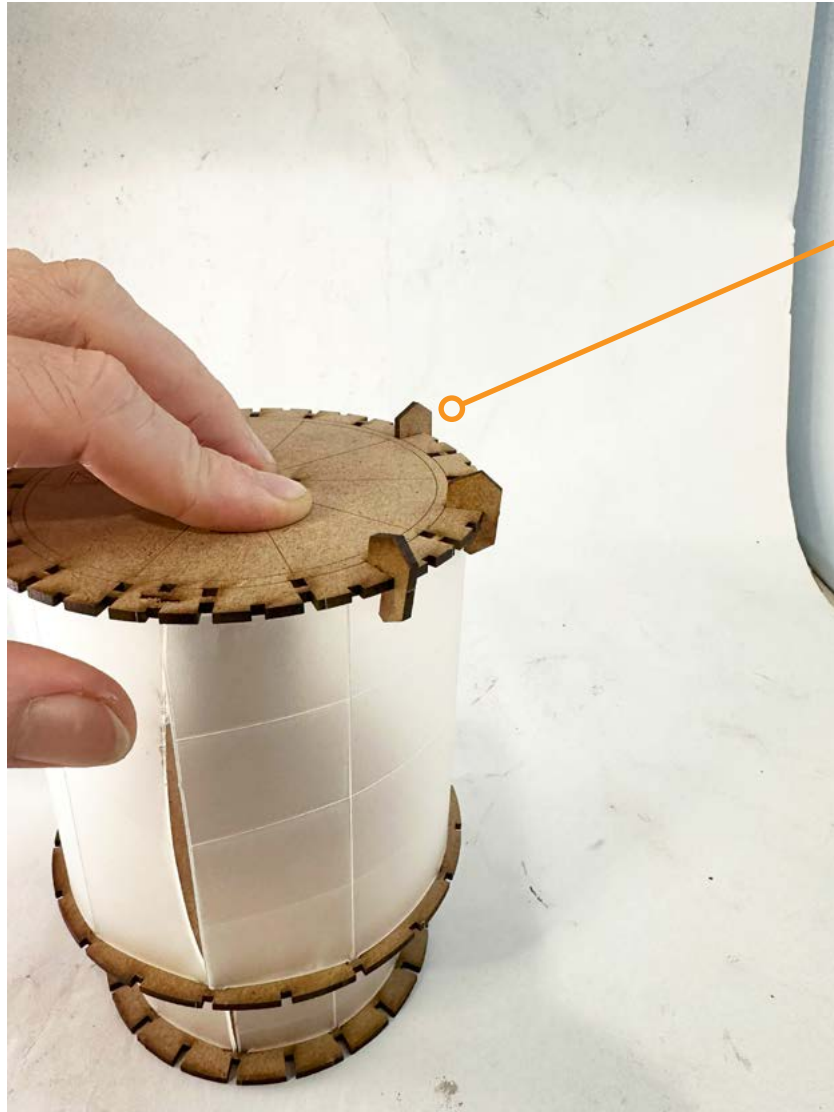

Place these to secure the fadelight

You can use rubber bands to help keep the fadelight plastic from flexing too much







Glue the  
columns  
in place one by  
one,  
alternating to  
keep it even





This colum has a hook to secure the fadelight plastic gap



The hole next to the fadelight joint is where the hooked column should be placed





Use a rubber band while the glue is drying to keep it in place

Don't forget the roof condensers!



Glue the 4 walls to the ground slab as shown.



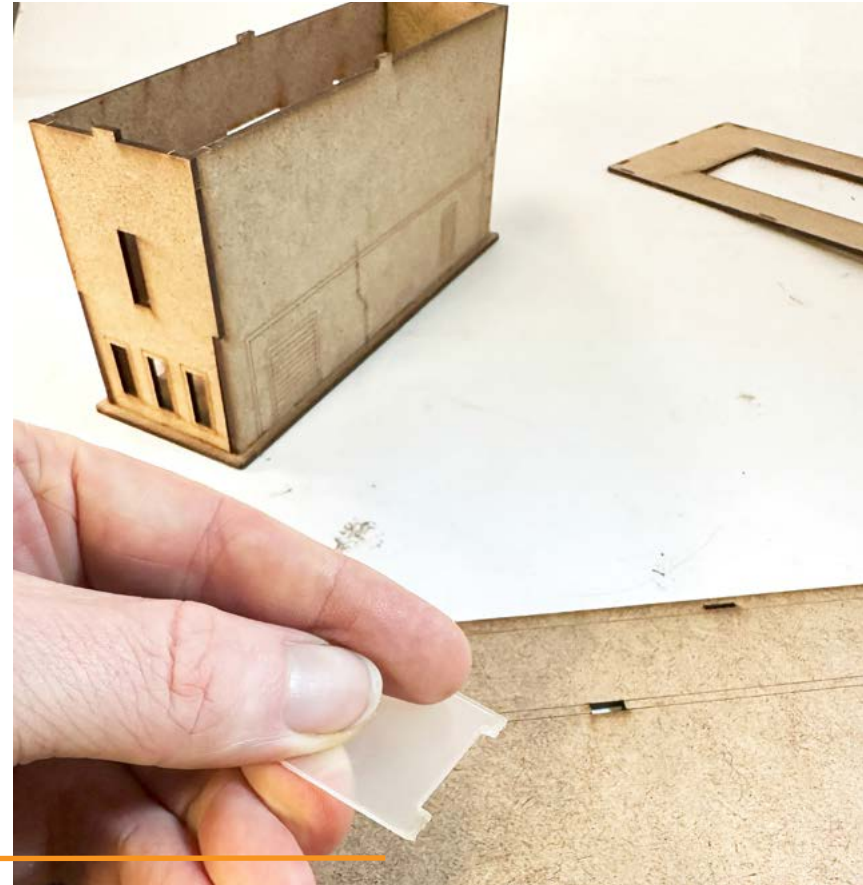
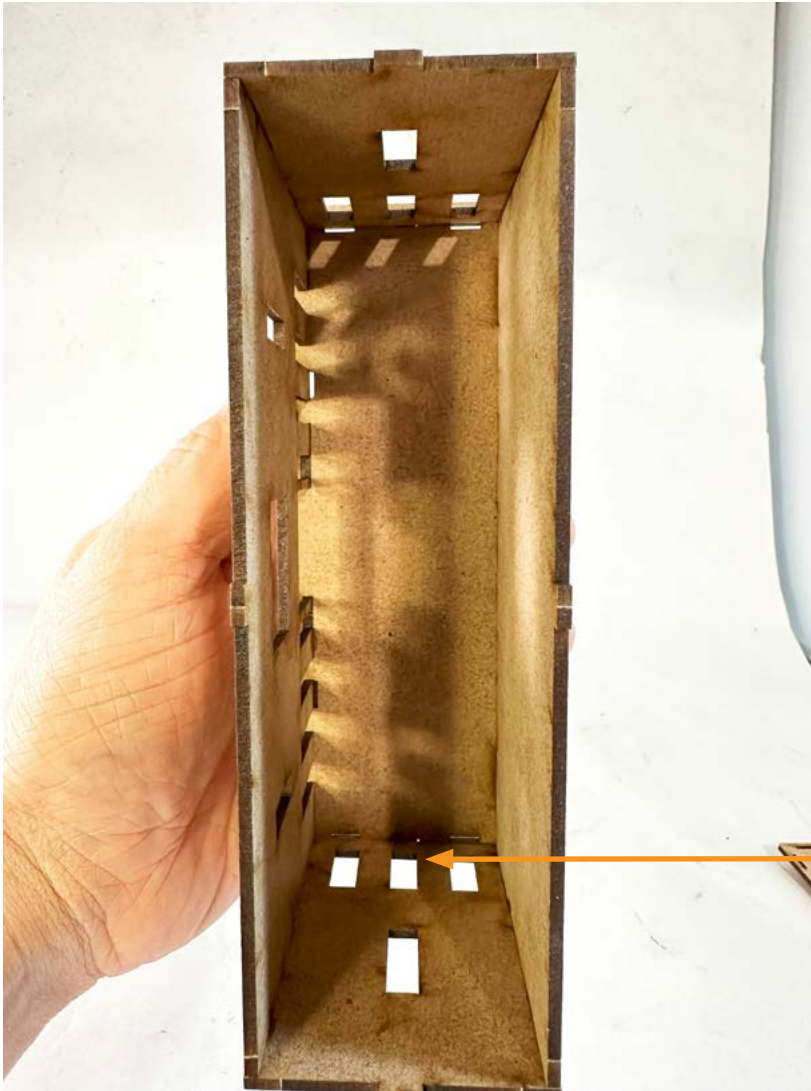

Slide the small fadelight pieces to the slots in the slab

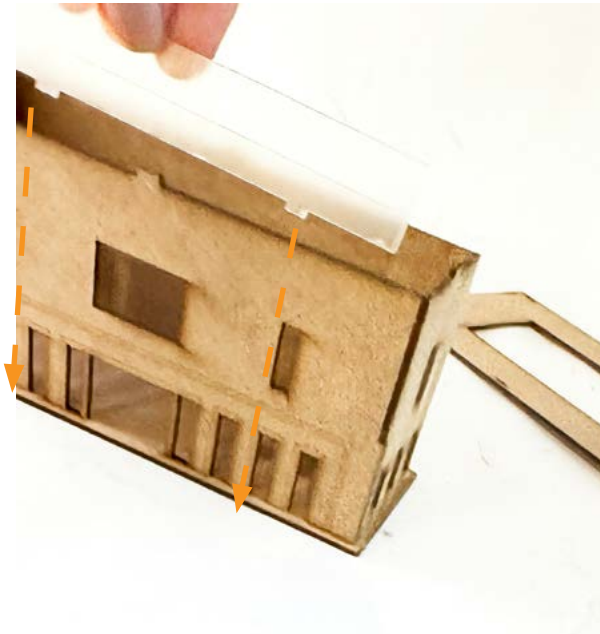

Slide the long  
fadelight piece  
into the ground  
floor slab slots





Slide the 4 fadelight plastic parts into the slab with the hole





When you have all 4 fadelight plastic parts in place, fix the fadelight tabs to the roof slab slots.

It can be easier to use the hole so you hand can place the slots and tabs together.

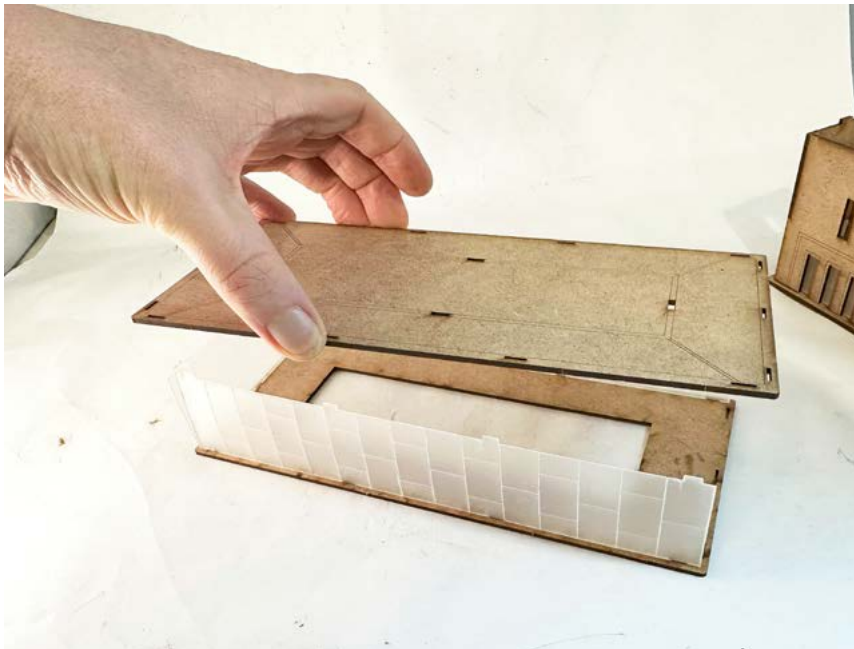

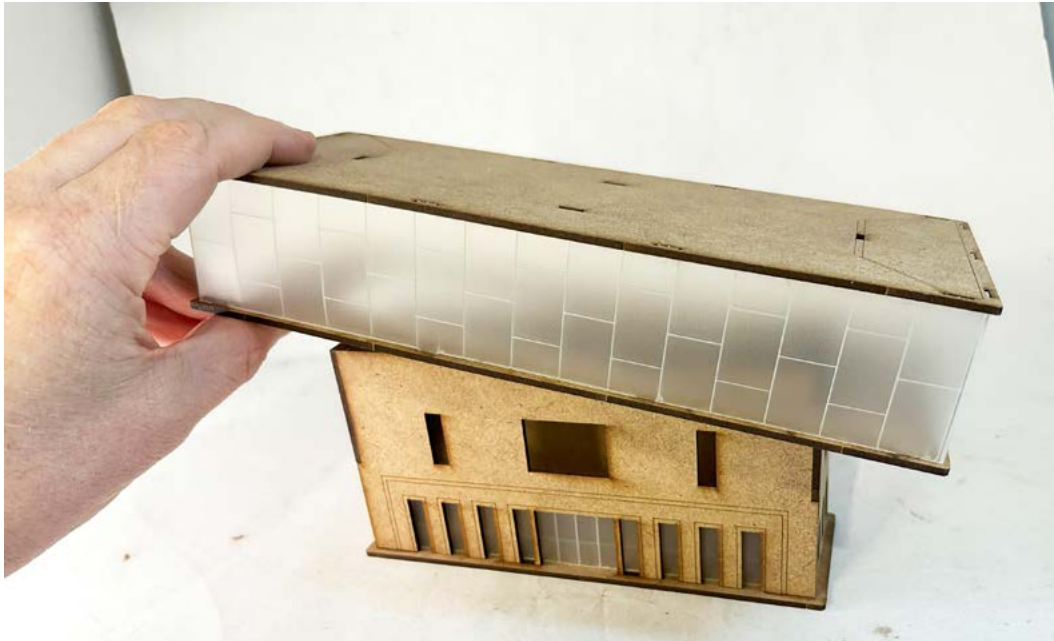

You can now glue the roof to the inner walls

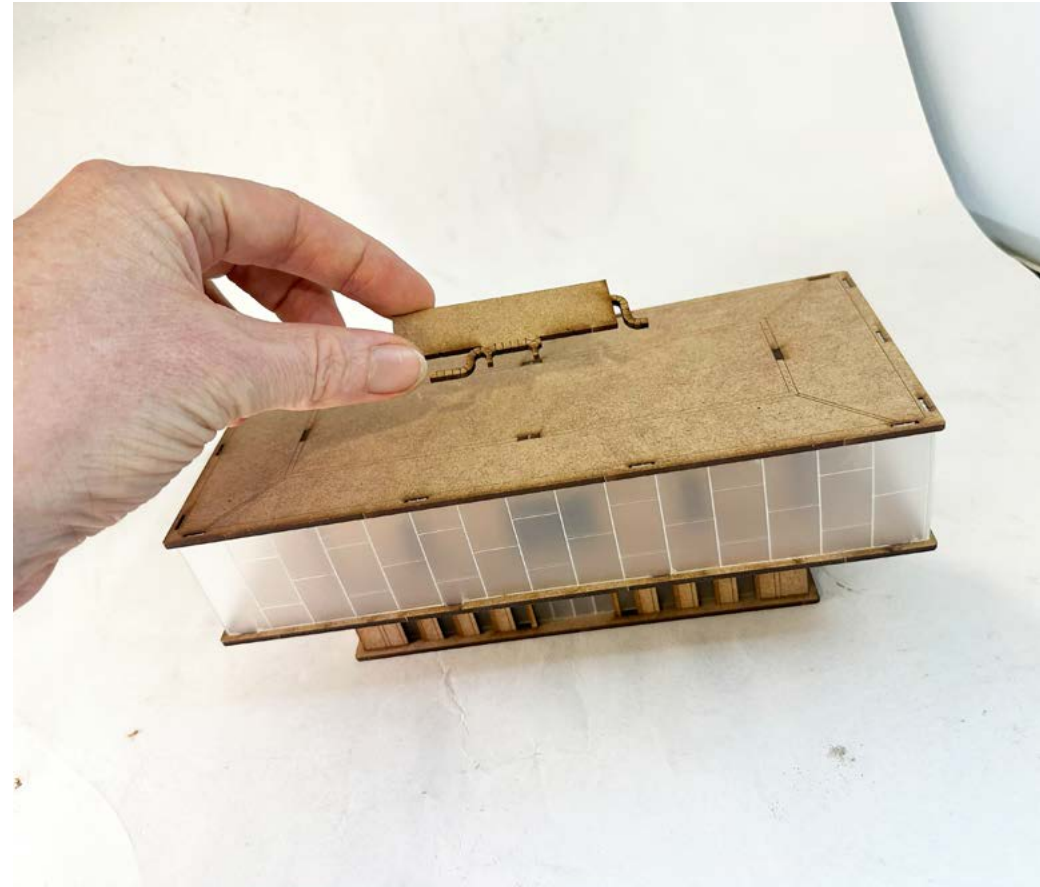





(The next page shows the earlier steps)  
Before gluing the columns, Pay attention to  
make sure the columns with nubs at the top  
line up with the main roof slab.

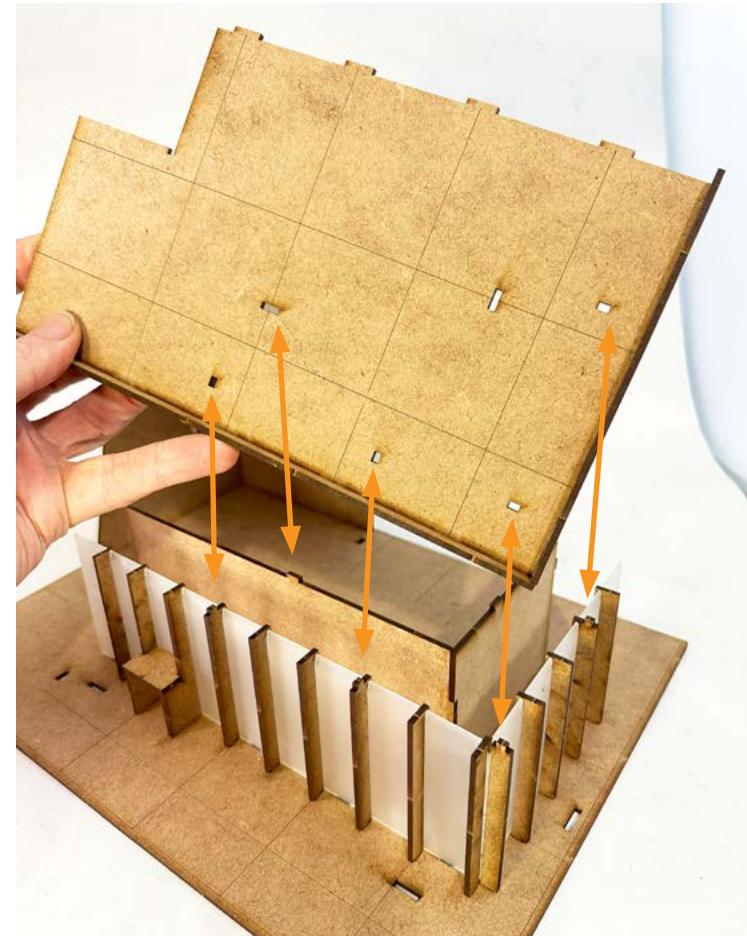

Glue the pieces as shown and let dry - they will need to be dry to resist the placement of the fadelight plastic later. Everything shown should be painted before final assembly.



These pieces are the inside faces fadelight used for building D (The textured side is the external side)

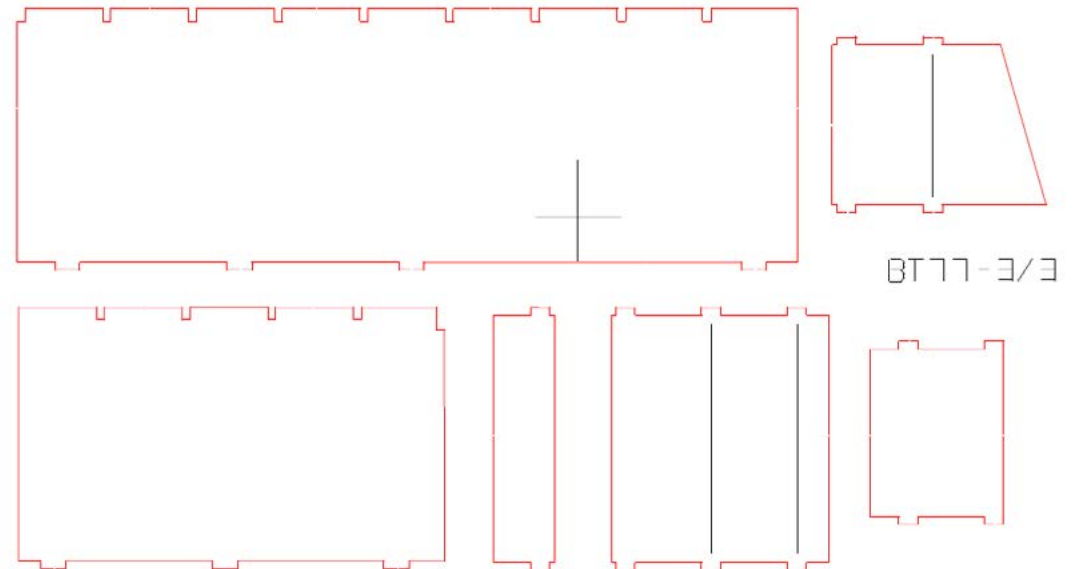

This column on the corner has no hook

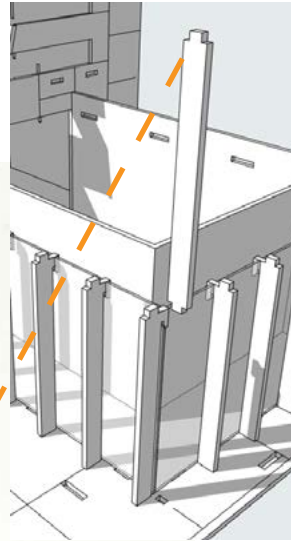

3 columns have tabs at the top which correspond to the slots in the roof slab

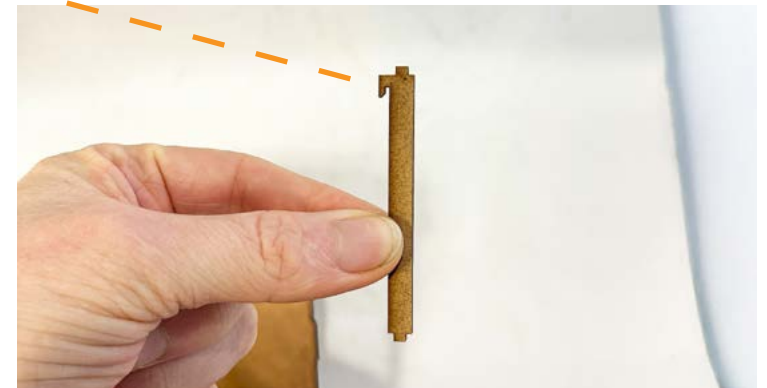
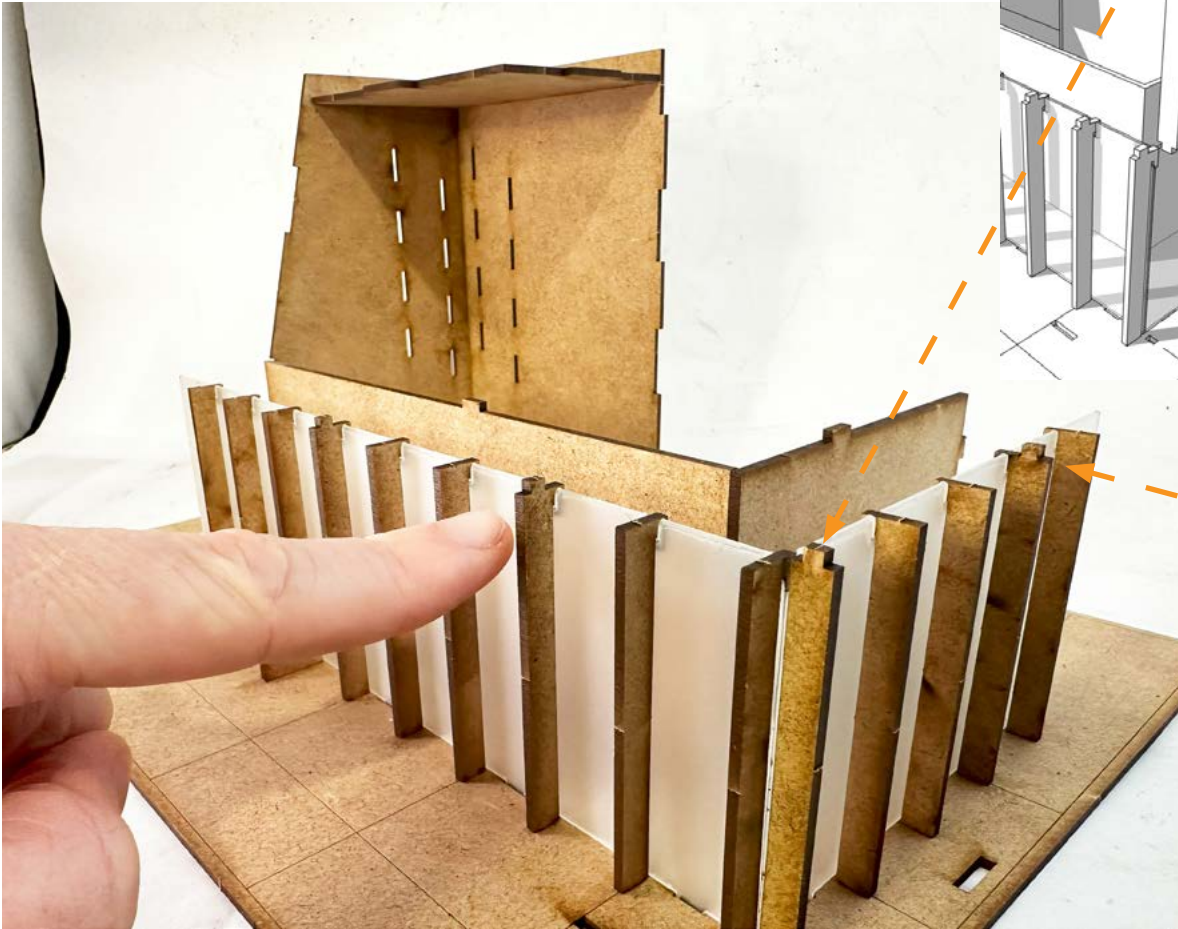

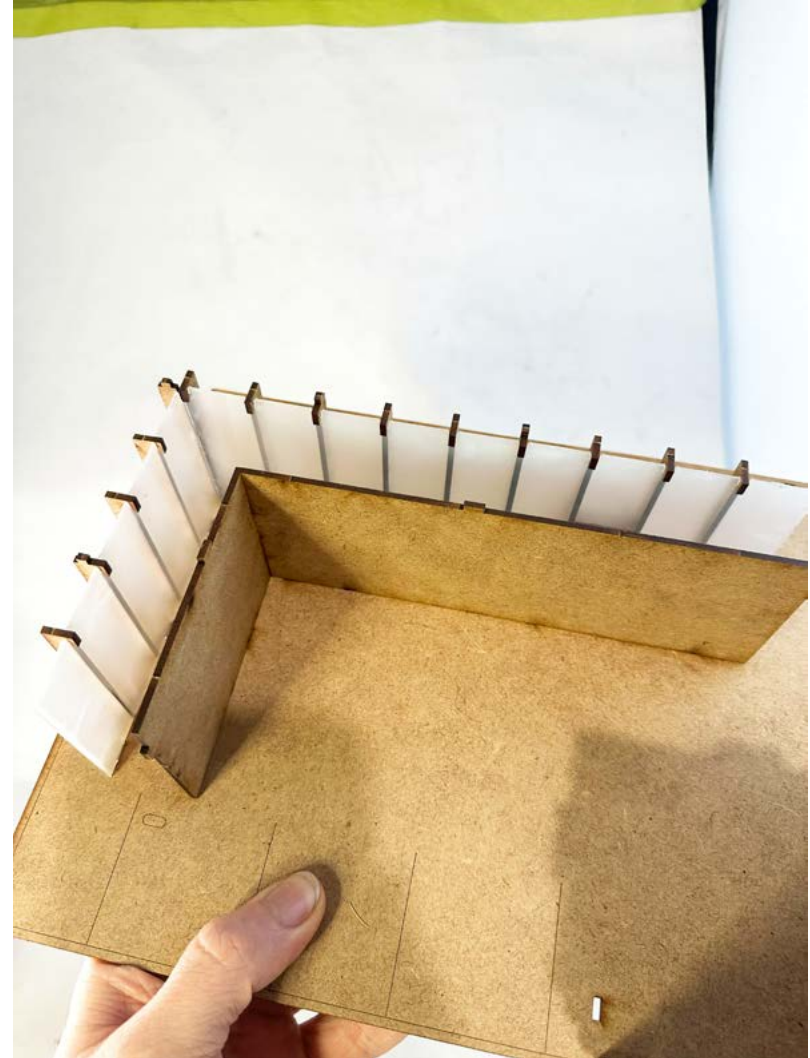
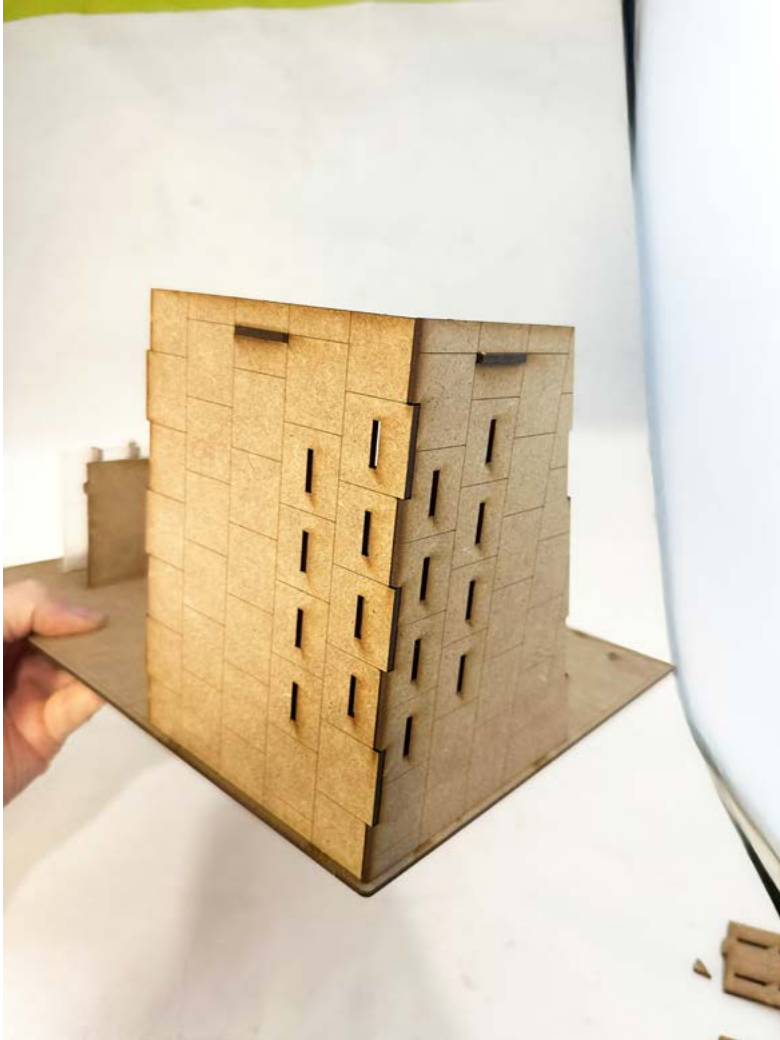

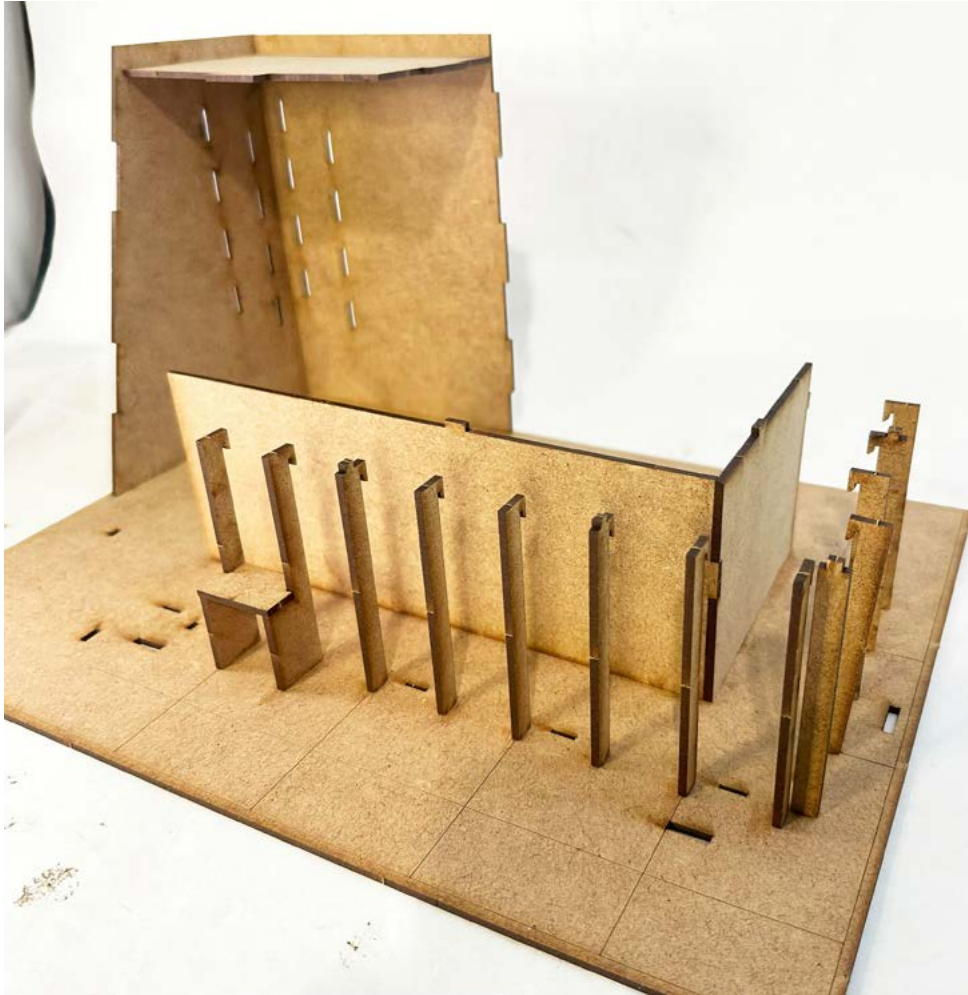

The textured, external side of the fadelight should be placed as shown so the door engraving matches the entrance.

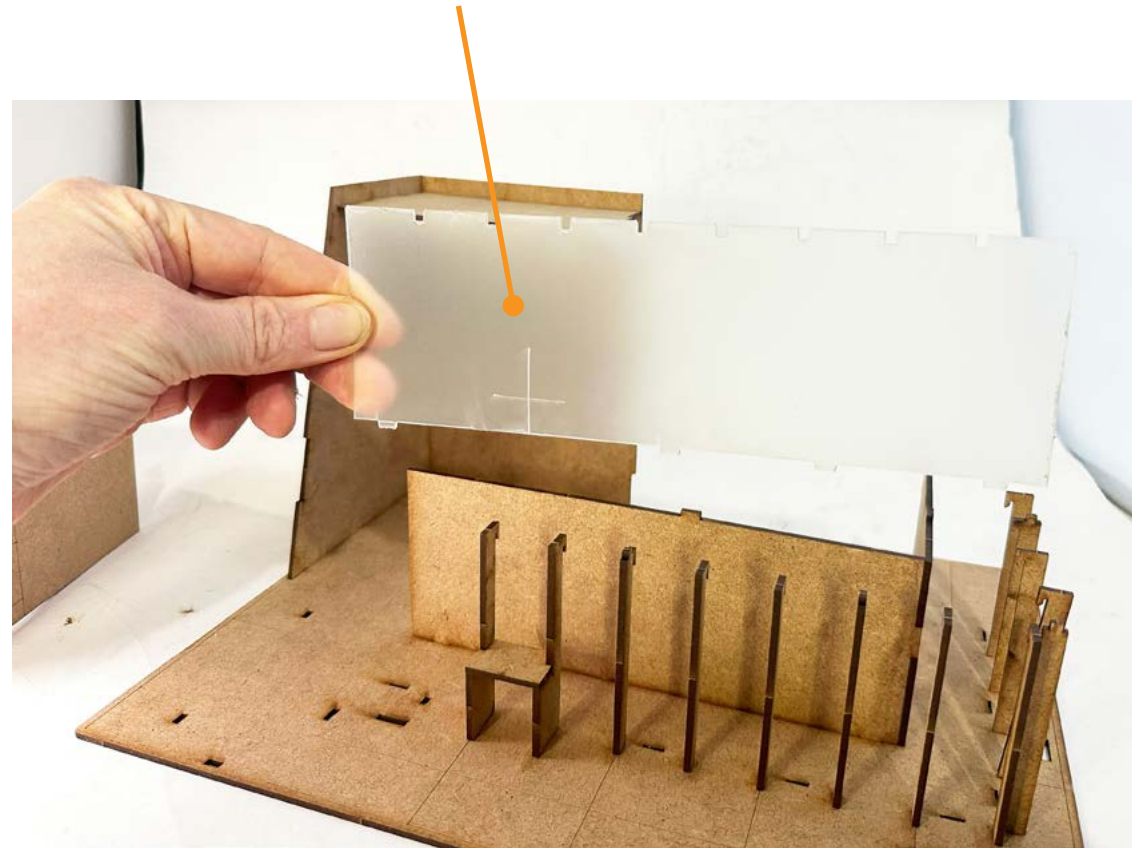



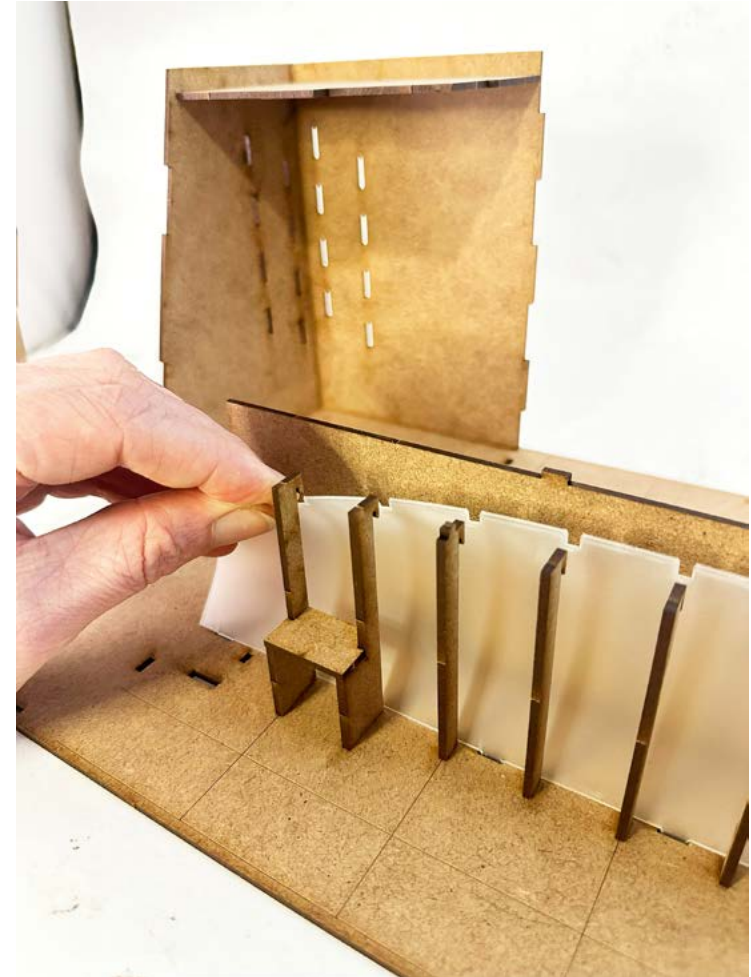
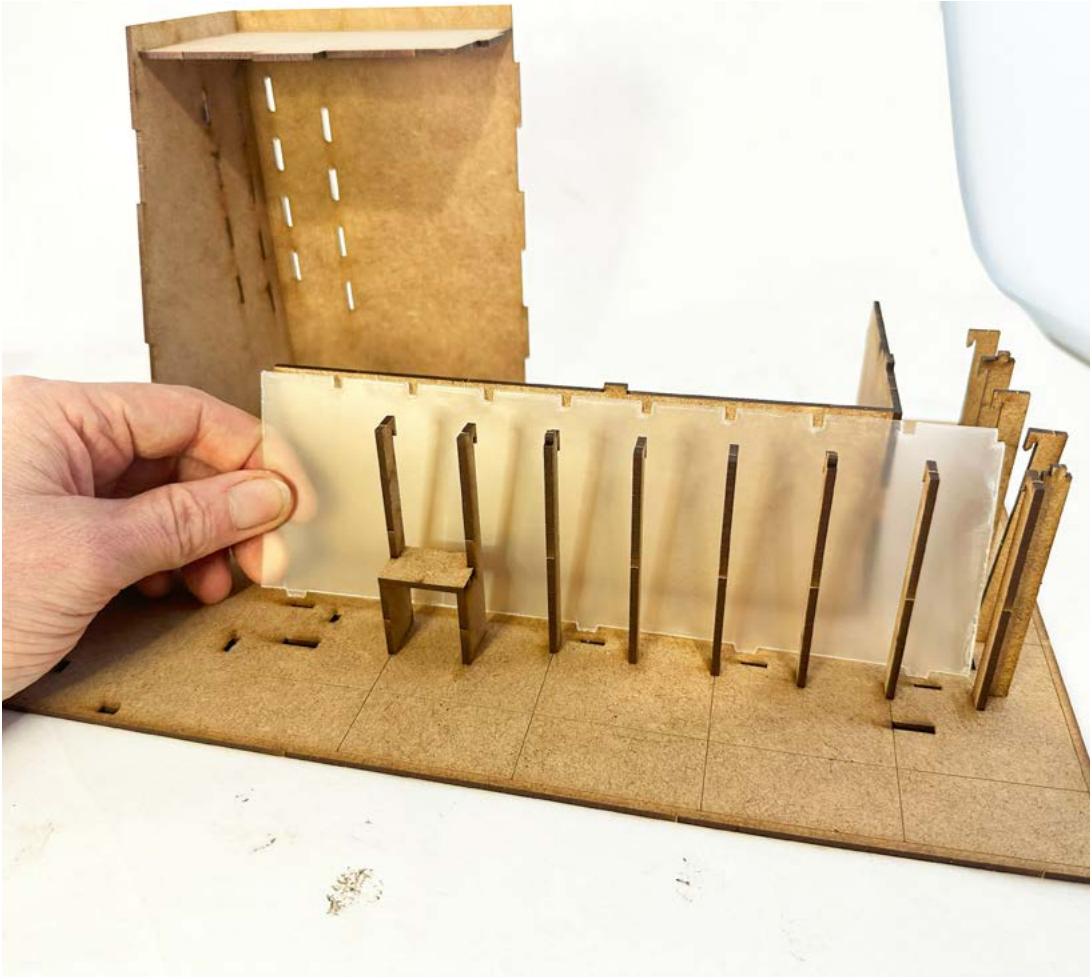

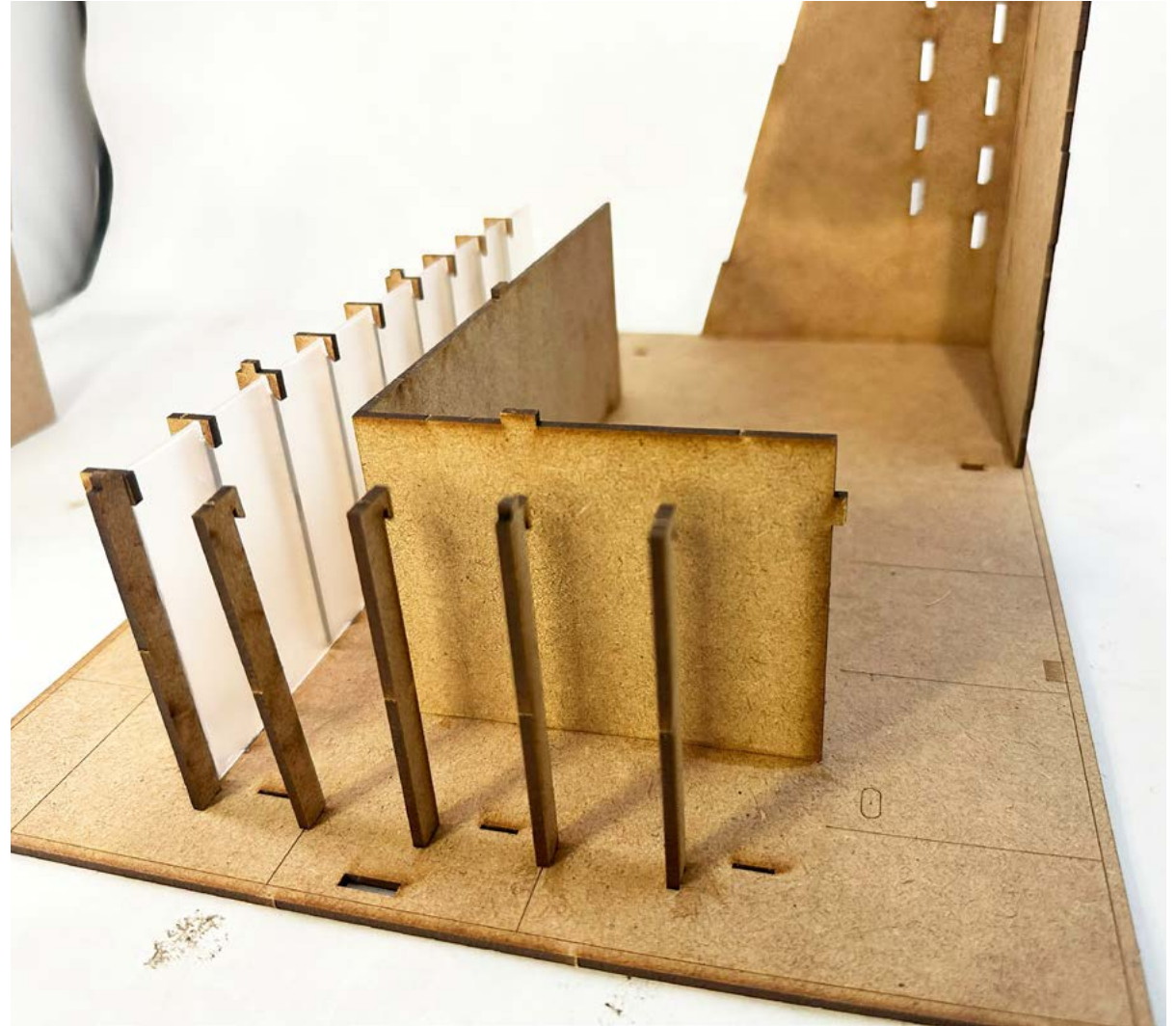

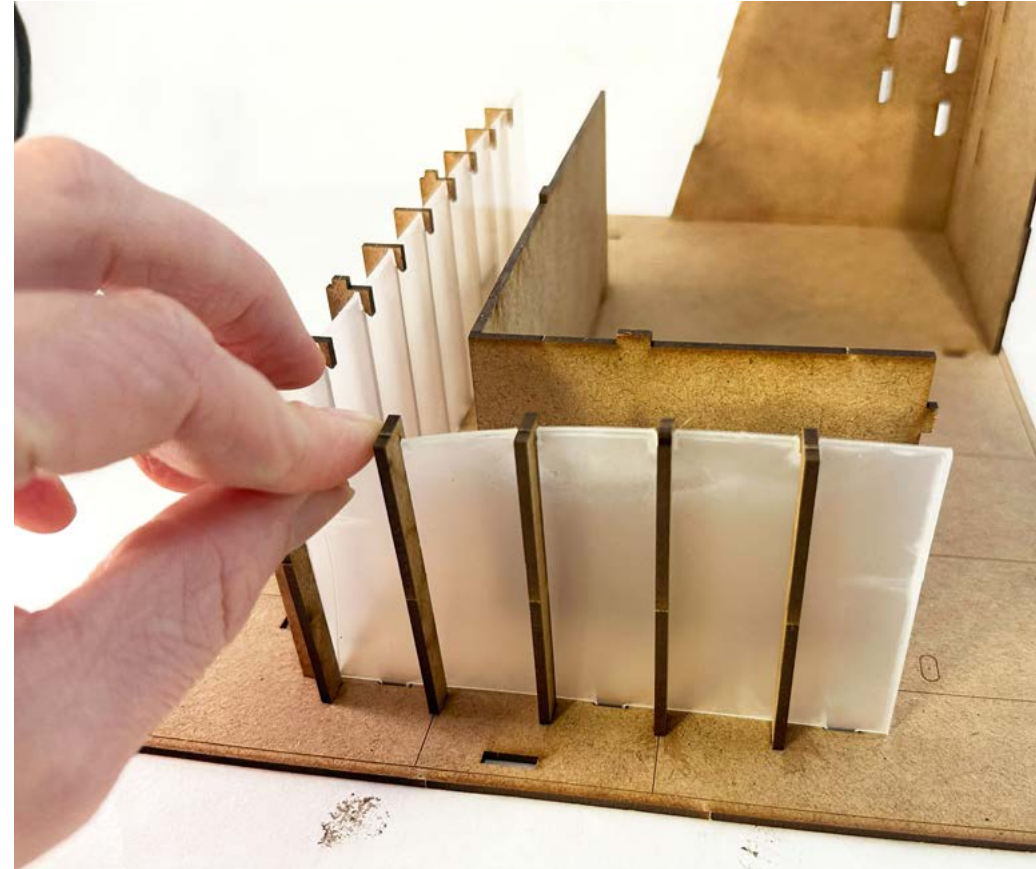
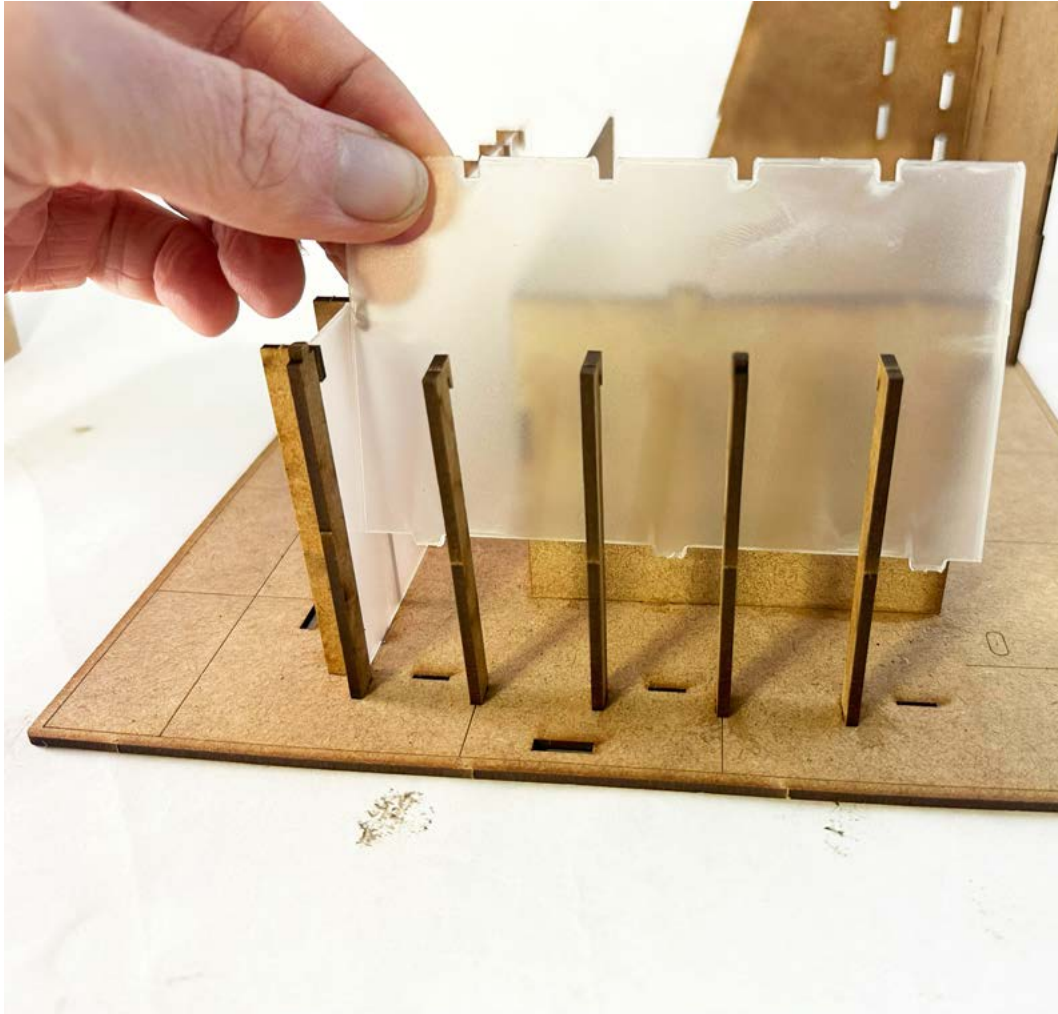

Carefully bend the fadelight into the hooks in the column as shown

Slot the fadelight plastic into the slots in the tabs. No glue required for the fadelight.

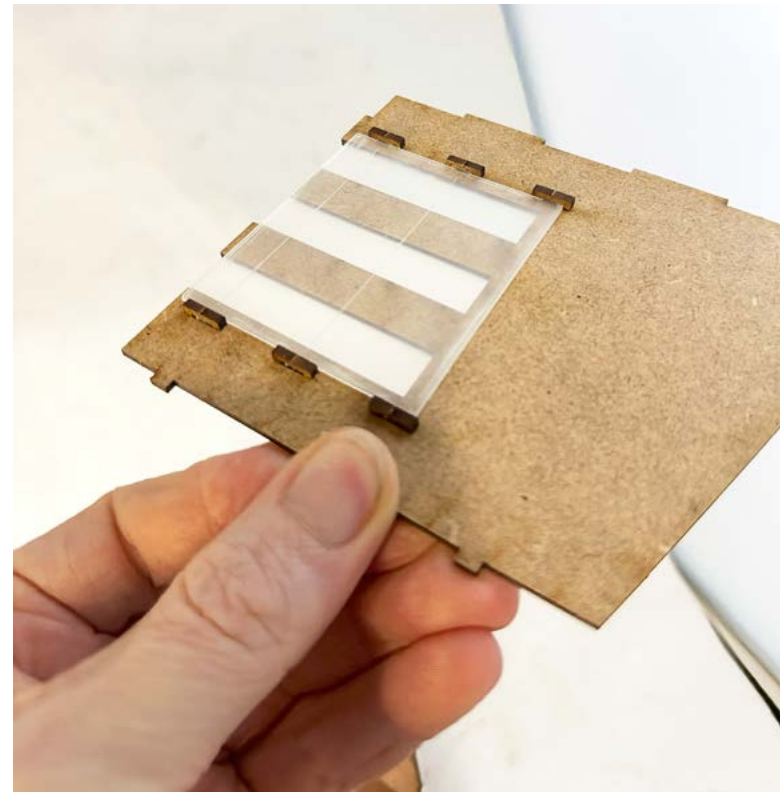
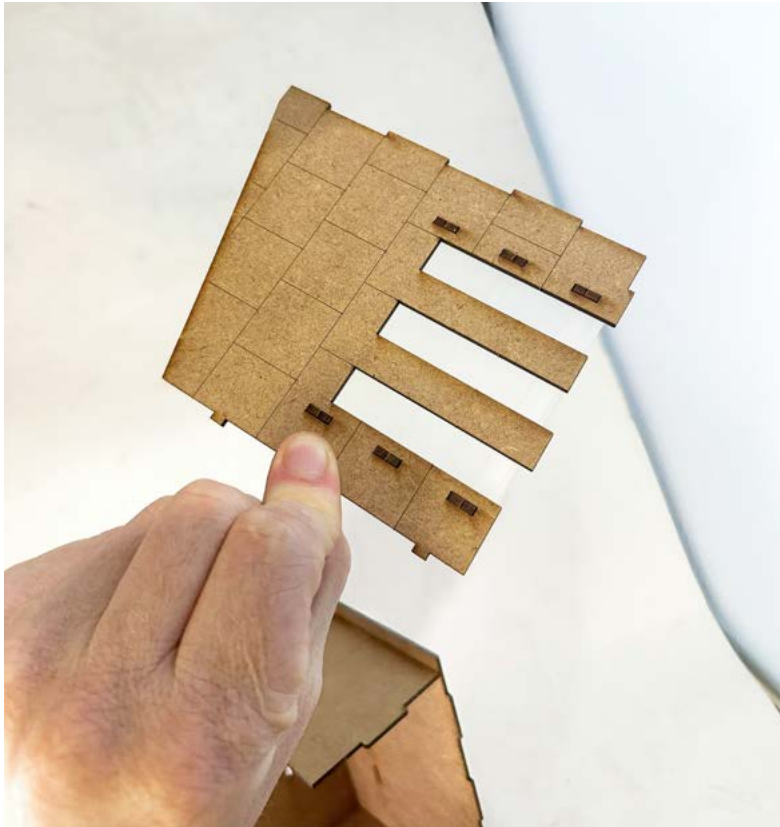



Slot the fadelight plastic into the slots in the tabs. No glue required for the fadelight.



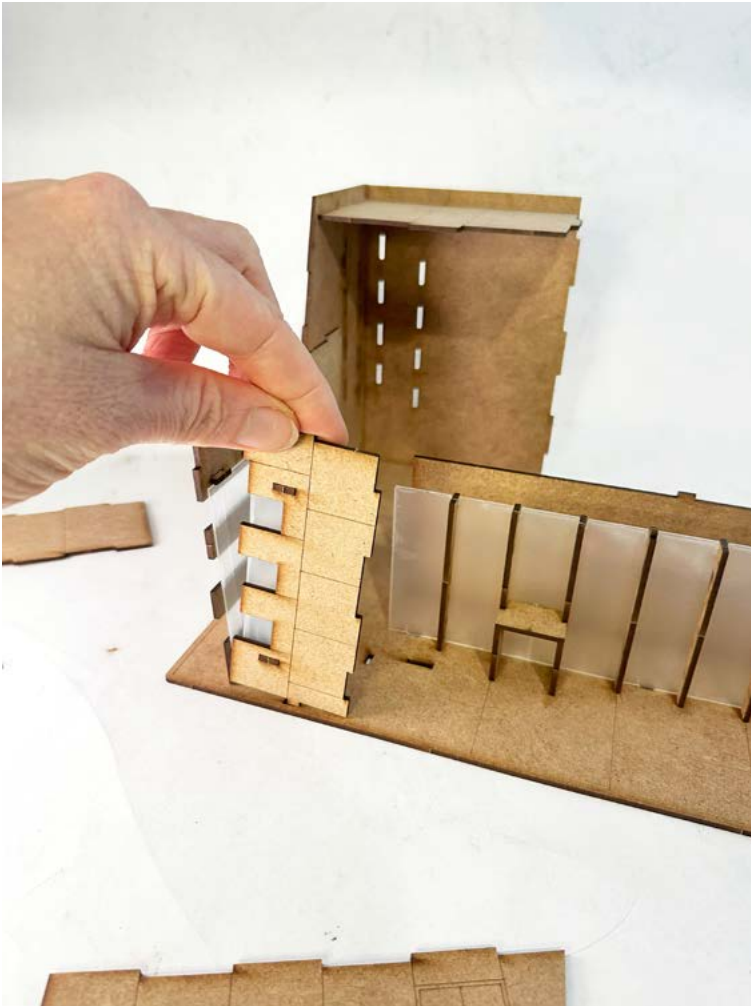

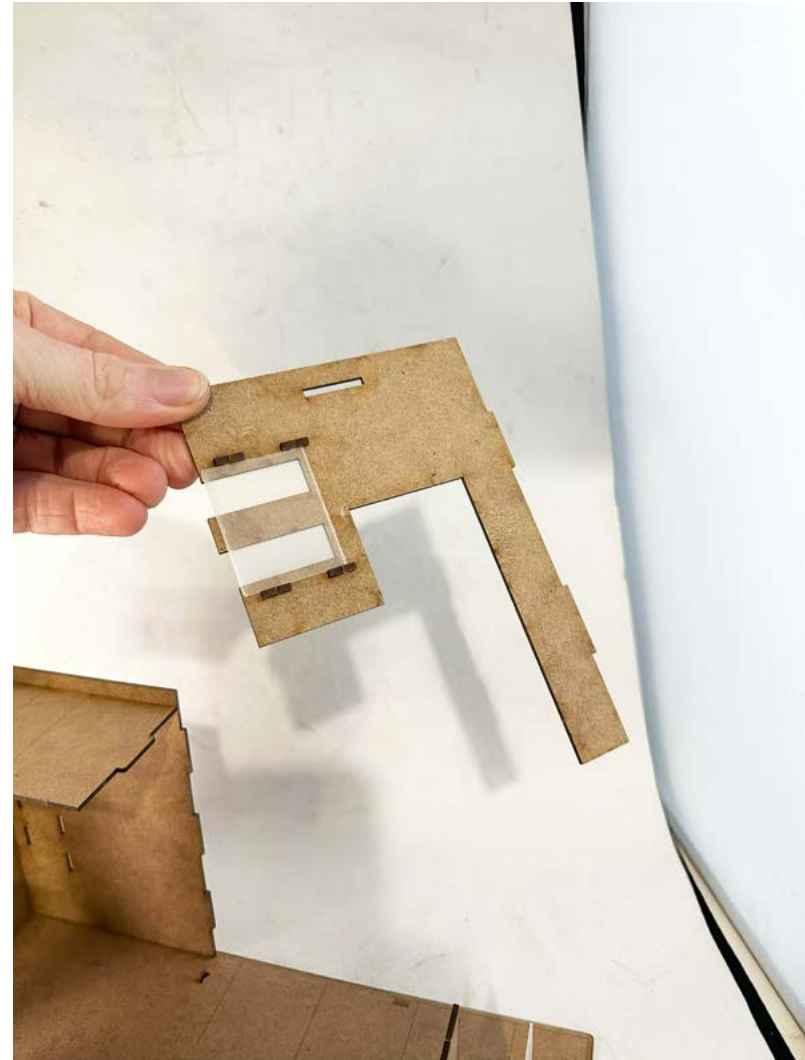

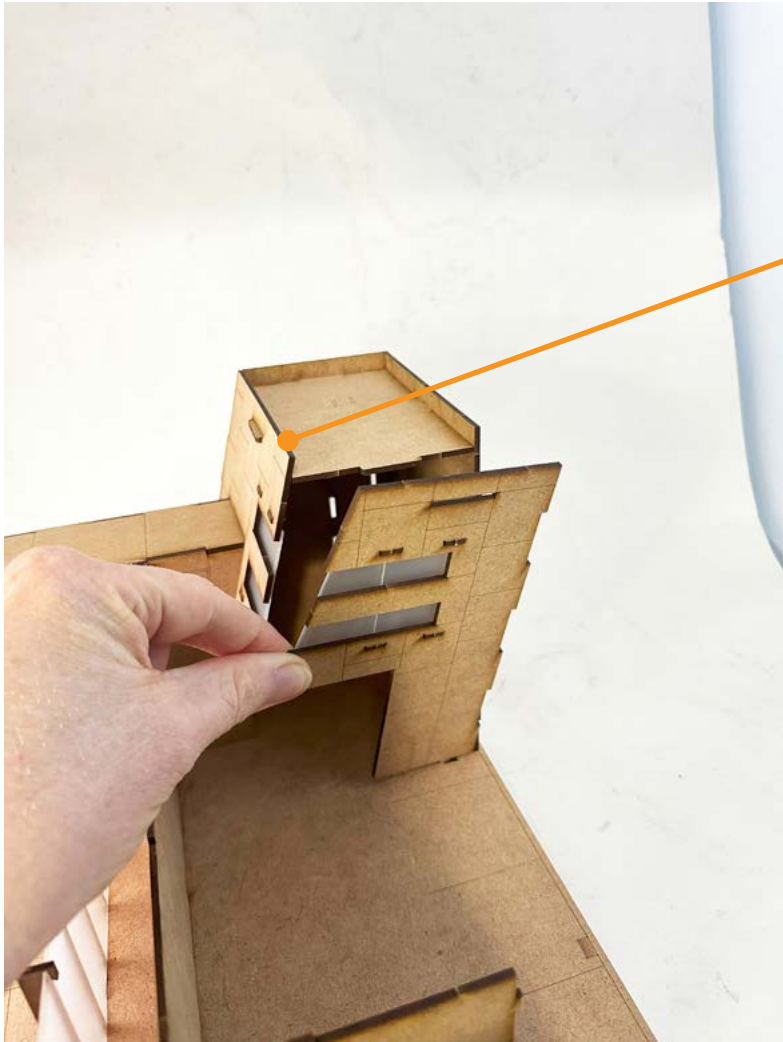

fix previous  
piece here





Make sure the roof ballustrade matches the height of the rear wall (Dry fit to make sure you have it the right way up, there's a slight difference)

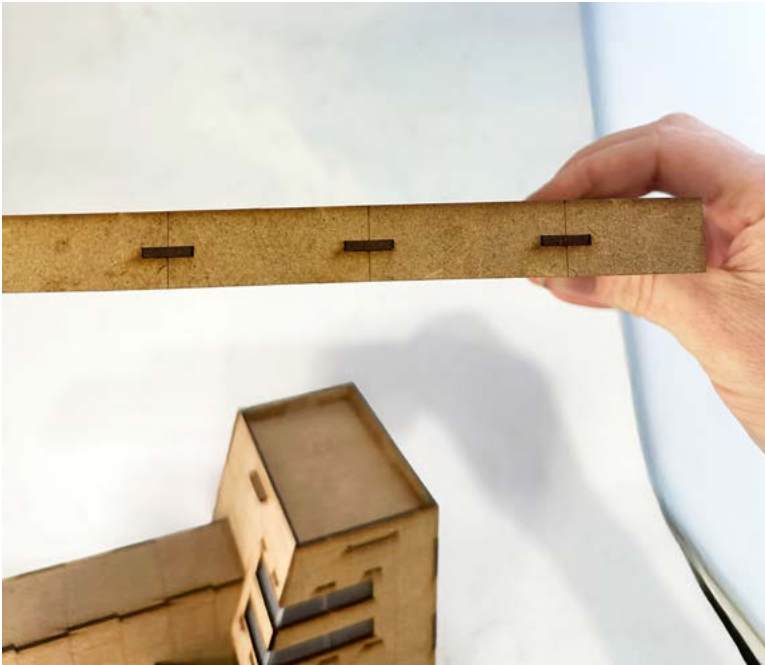

Pay attention to carefully line up the nubs with the slots of the roof slab



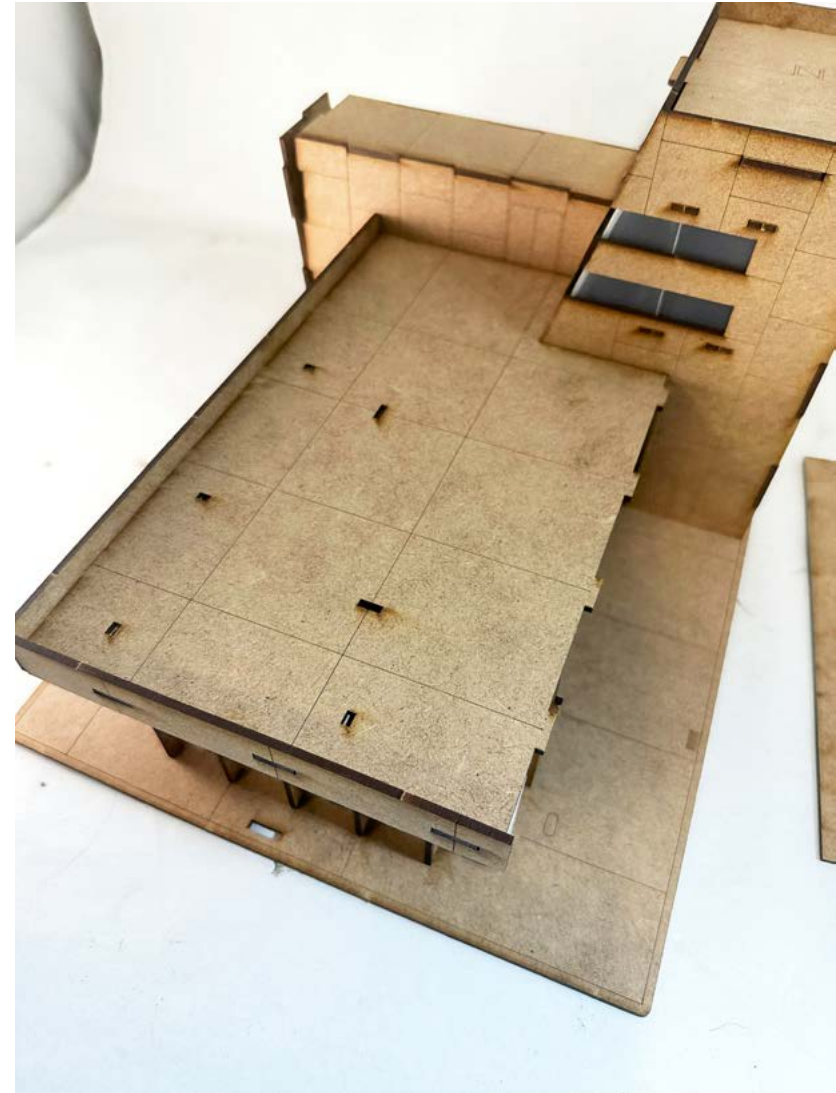
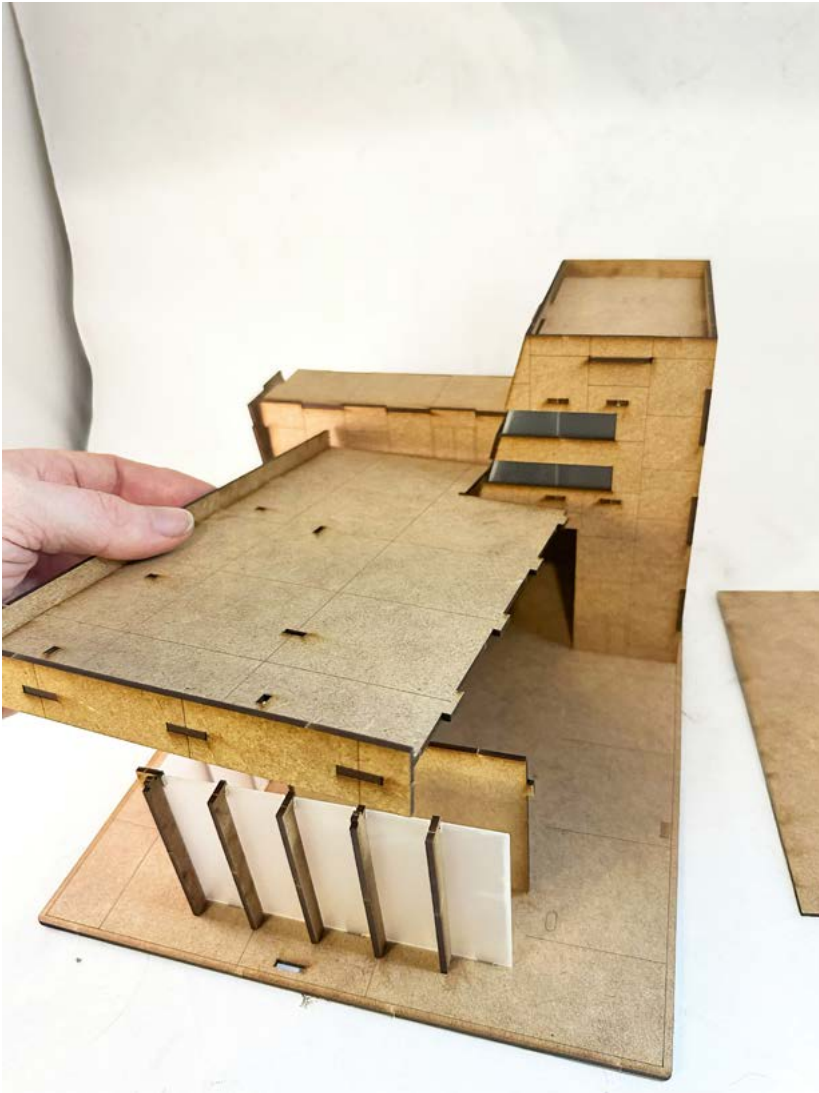

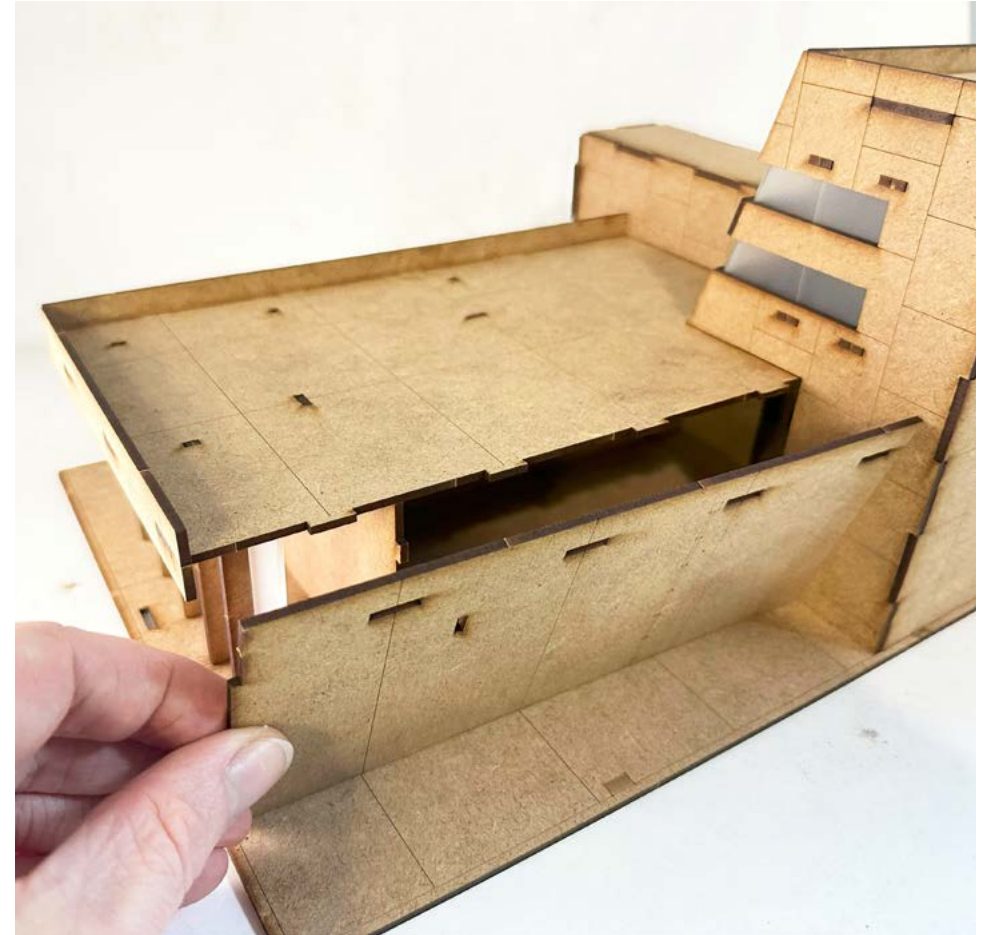



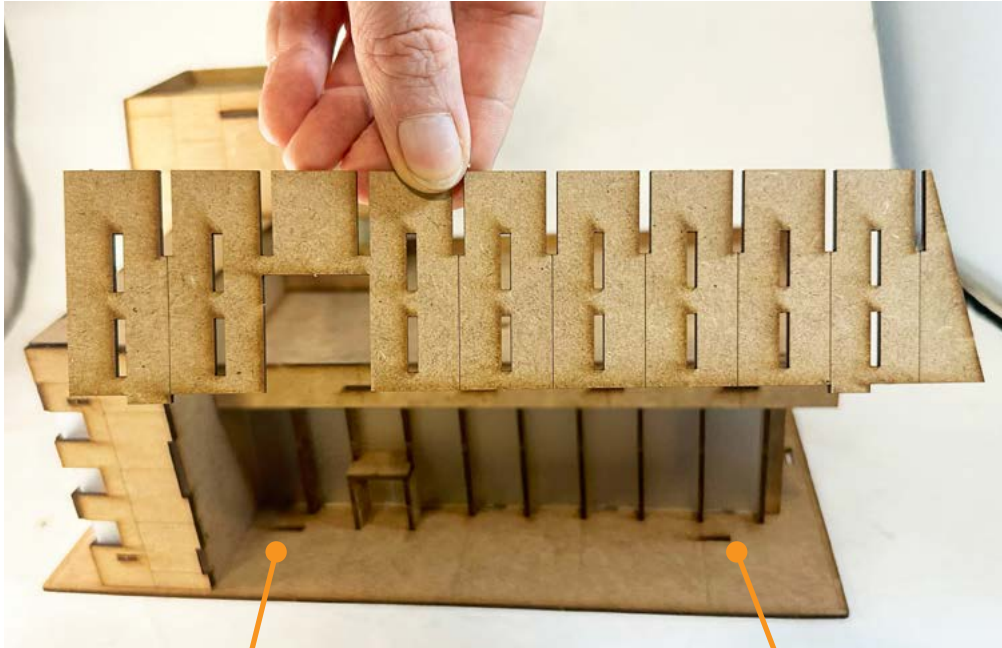

Do not glue these optional facades - they just sit in the slots and allow you to turn the museum/public building into a more secure fortress for sci-fi games.



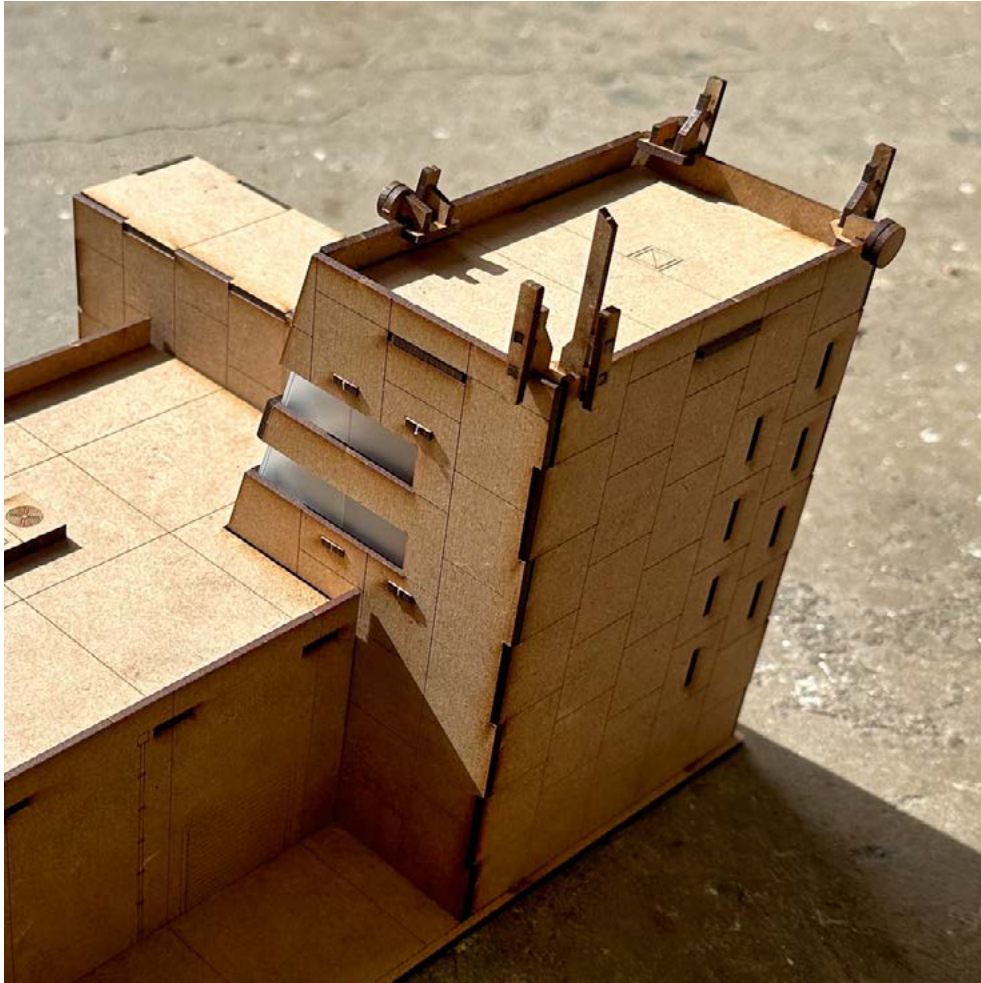

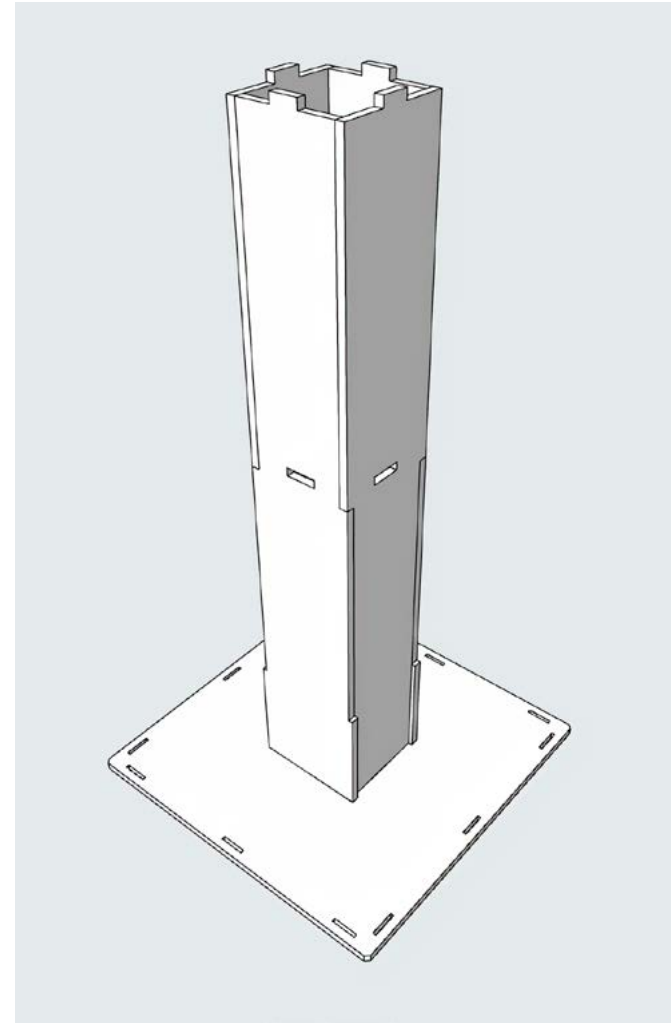
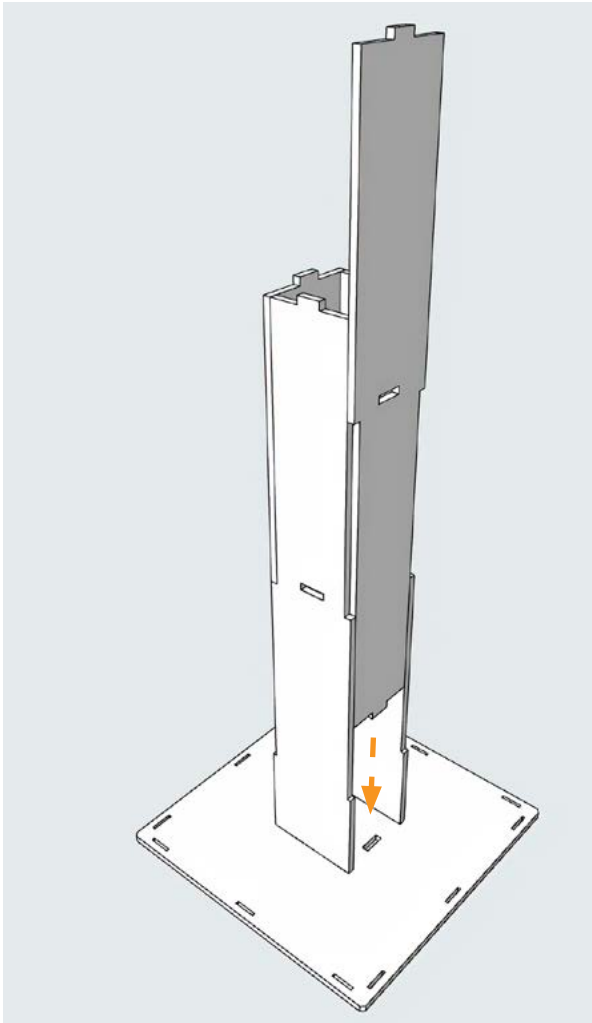



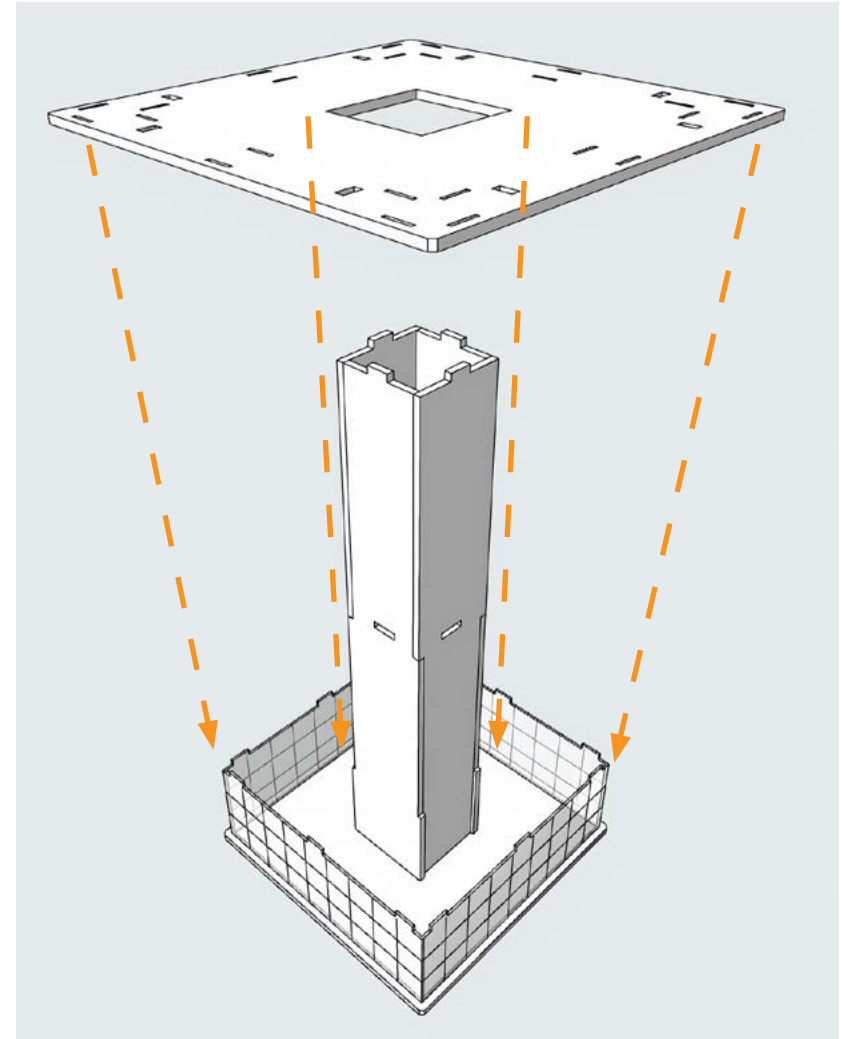
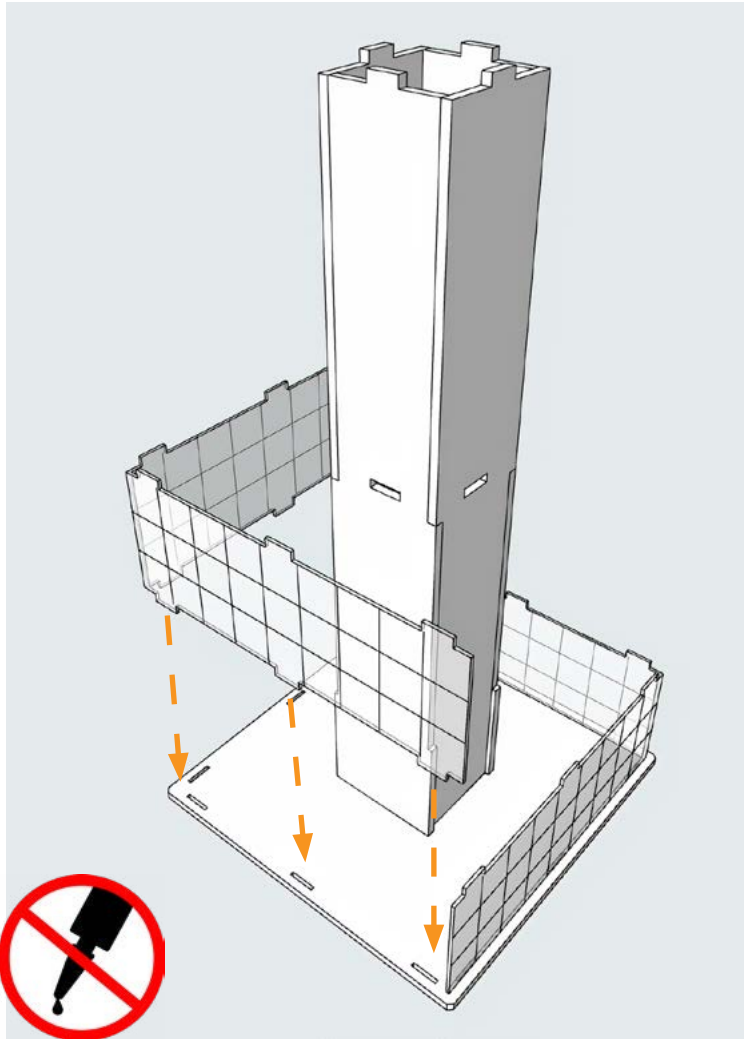

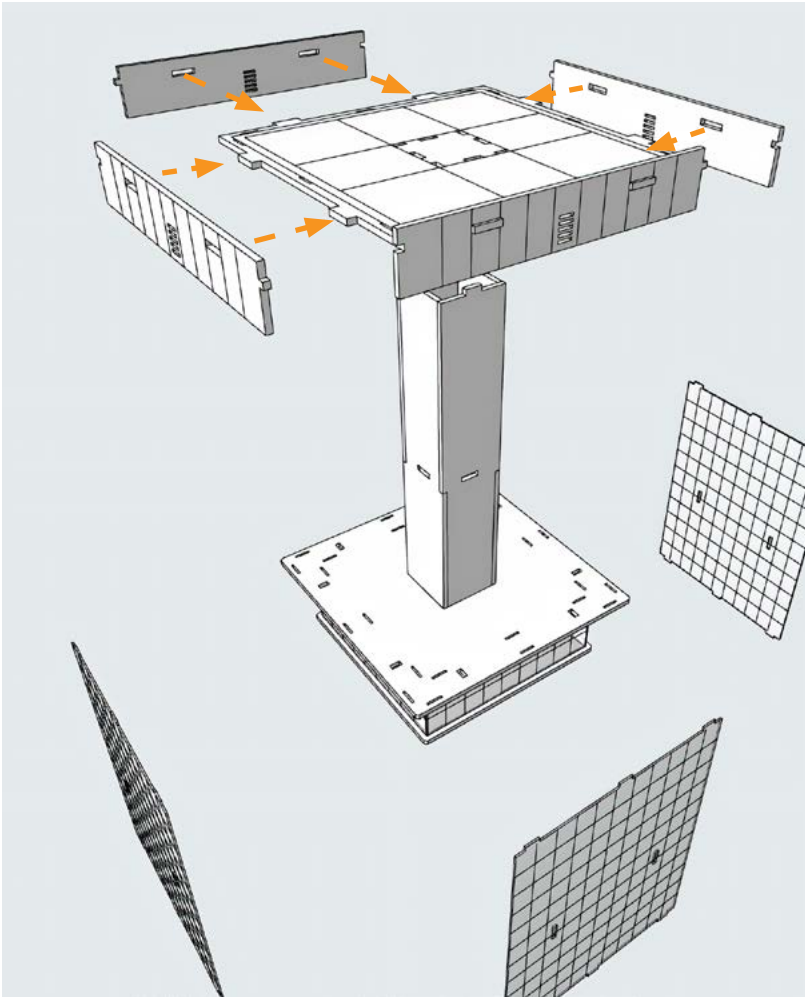

I found it easiest to attach the Fadelight plastic to the top roof slab first, (1.) while upside down. Then insert the tabs into the lower ceiling tab. (2.)

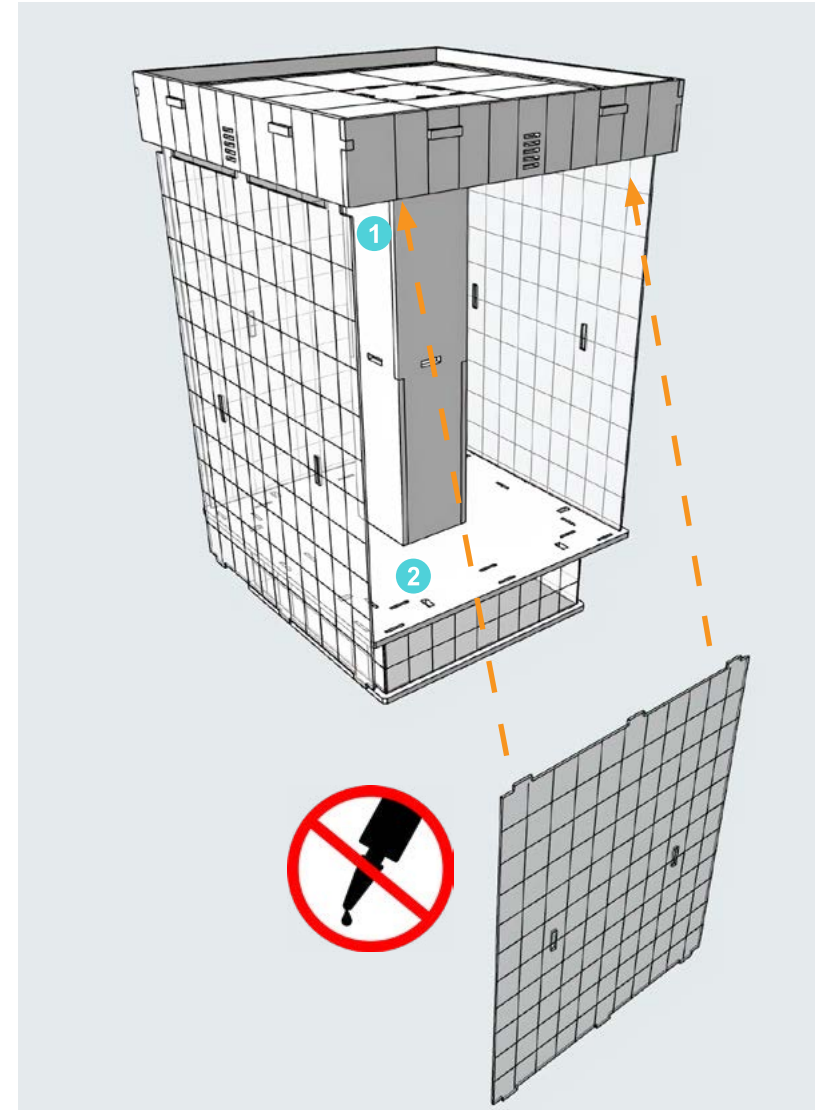

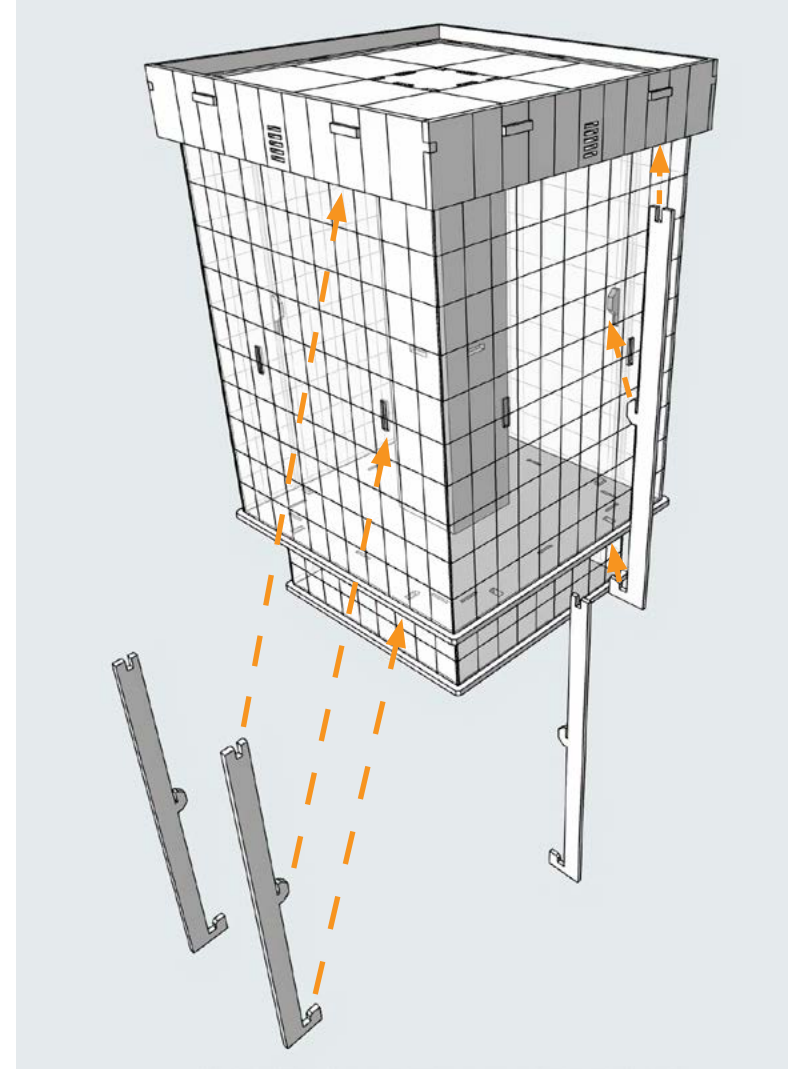
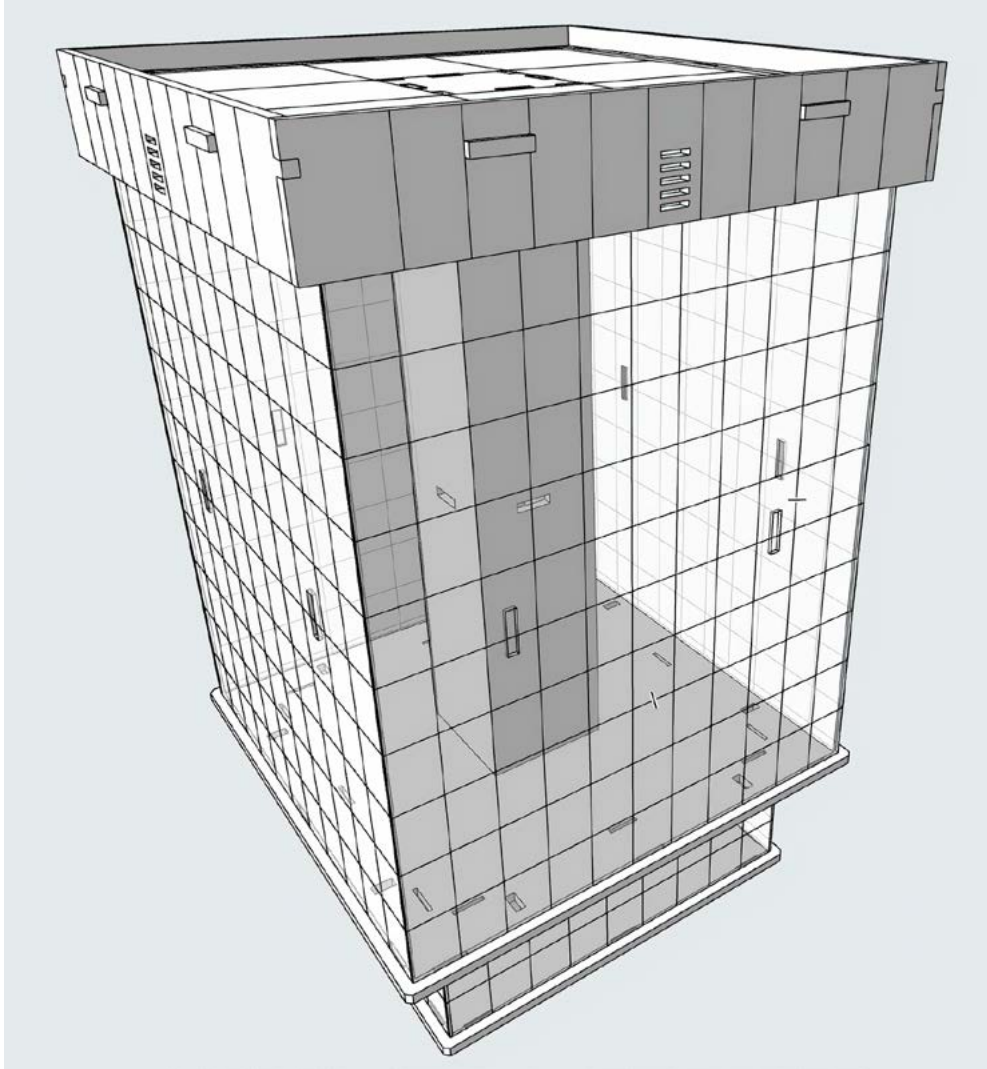

Now you just have to glue the 3 sides and the roof of the plant room / A/C Condenser

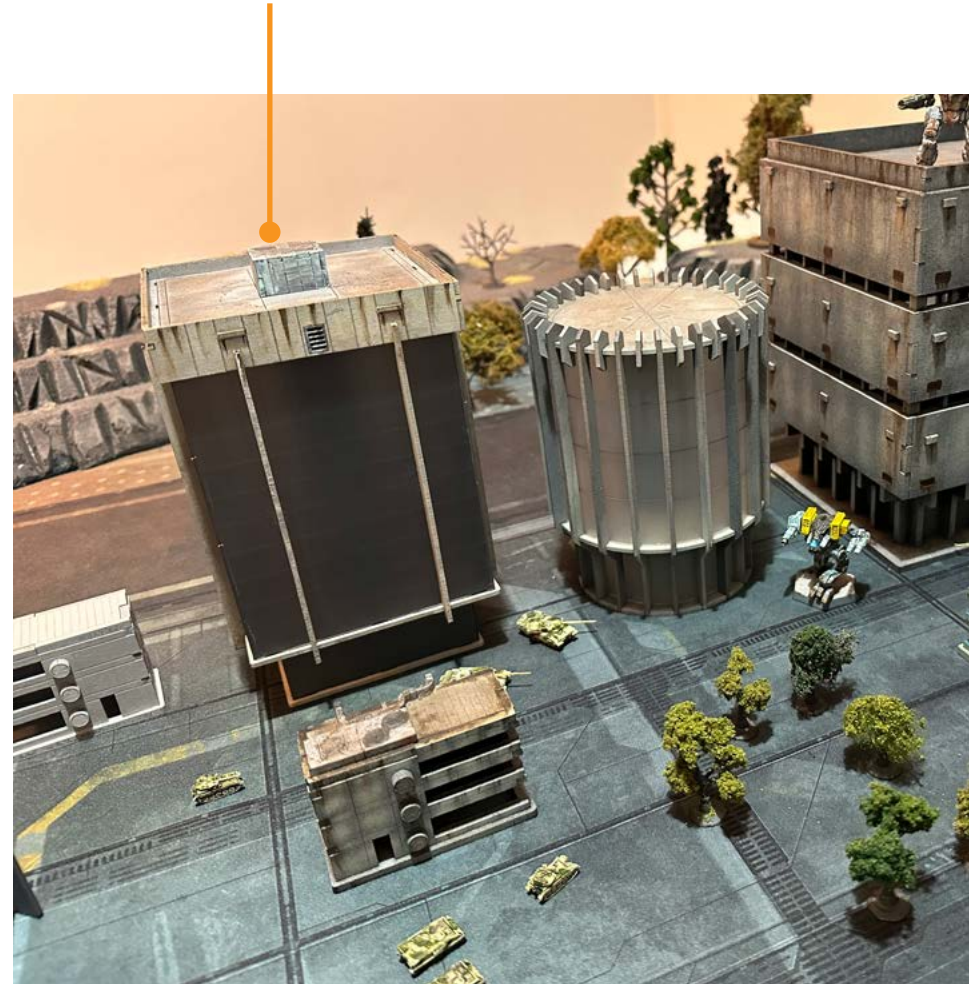
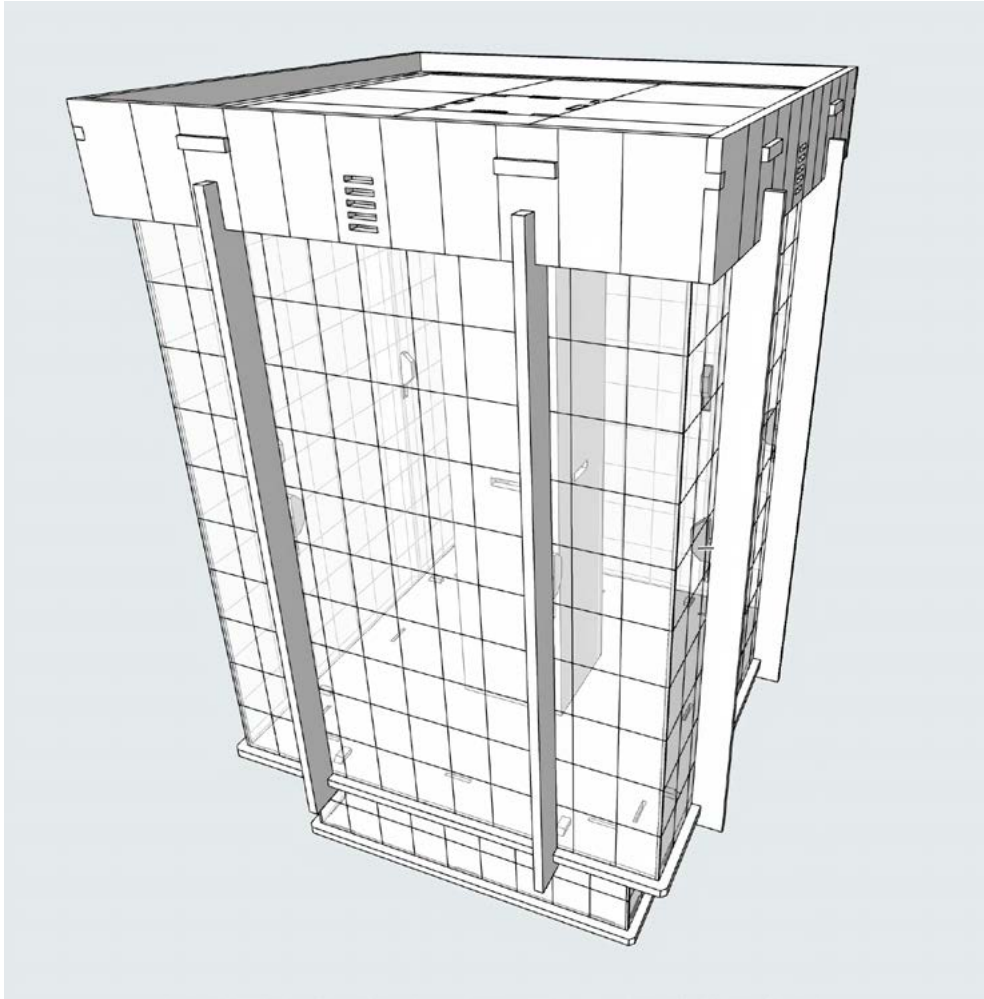

## BRUTALIST CIVIC CENTRE INSTRUCTIONS

Enjoy your new terrain! Any feedback is most welcome. Again, if you have any issues please message me in the chat at [brutalcities.com](https://brutalcities.com)



Miniatures copyright Games Workshop