

7-OM-A-2.5

OVERHEAD MNT, ADJUSTABLE, 2.5" BASE, SPRING (OPTIONAL)
Mounts to 2-3/8"+ round posts, 2-1/2+ square posts and all lamp standards

Commonly used throughout North America · Backed by a one-year manufacturer warranty

Product Specifications:

- Extruded aluminum, will not rust, 100% recyclable
- Mill finish
- Also available in a powder coated or painted finish
- Slot-free design is compatible with all sign thicknesses
- Adjustable 15"-19" length
- Features Windless® design:
 - ▶ Built to relieve stress on posts and signs even in extreme winds
 - ▶ Can easily convert to free-swing by removing springs
- Pre-assembled for convenience with stainless steel hardware
- 7-ADAPTER-5-1 available for sign box mounting
- Strap to post
- Bolt thru sign mounting

Testing Specifications:

- Post mounting fasteners tested at 100 in-lbs torque
- Sign mounting fasteners tested at 100 in-lbs torque
- Typically used with grade 18/8 fasteners

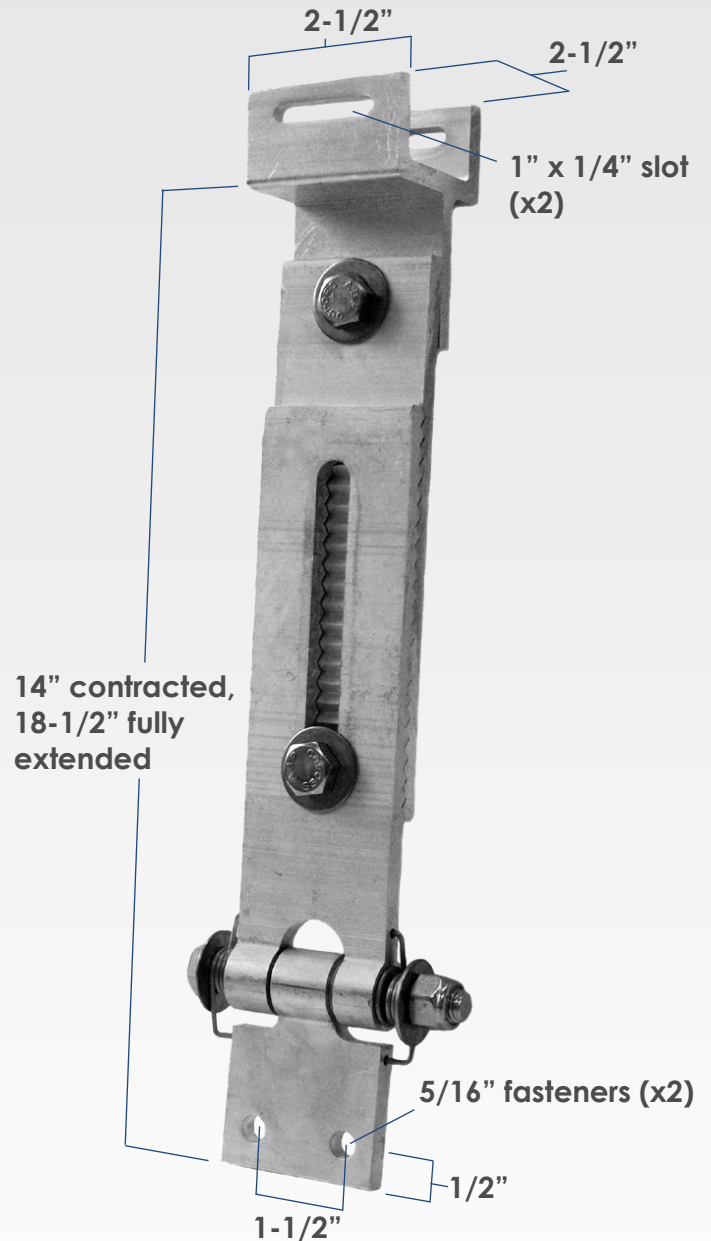

7-OM-A-2.5 Fastener Options

'SS' = Stainless Steel

7-OM-A-2.5

- includes no fasteners (we can even offer fasteners not listed in our catalogue)

7-OM-A-2.5-SS

- HEX HEAD BOLT, SS, 5/16"-18UNC X 1.5" (x2)
- HEX LOCK NUT, SS, 5/16"-18UNC (x2)
- FLAT WASHER, SS, 5/16"ID X 0.75"OD (x4)
- FLAT WASHER, NL, 5/16"ID X 0.75"OD (x2)



Dyna Engineering Ltd.
info@dynaengineers.com

dynaengineering.com

7-OM-A-4

OVERHEAD MNT, ADJUSTABLE, 4" BASE, SPRING (OPTIONAL)
Mounts to 2-3/8"+ round posts, 2-1/2+ square posts and all lamp standards

Commonly used throughout North America · Backed by a one-year manufacturer warranty

Product Specifications:

- Extruded aluminum, will not rust, 100% recyclable
- Mill finish
- Also available in a powder coated or painted finish
- Slot-free design is compatible with all sign thicknesses
- Adjustable 15"-19" length
- Features Windless® design:
 - ▶ Built to relieve stress on posts and signs even in extreme winds
 - ▶ Can easily convert to free-swing by removing springs
- Pre-assembled for convenience with stainless steel hardware
- 7-ADAPTER-5-1 available for sign box mounting
- Strap to post
- Bolt thru sign mounting

Testing Specifications:

- Post mounting fasteners tested at 100 in-lbs torque
- Sign mounting fasteners tested at 100 in-lbs torque
- Typically used with grade 18/8 fasteners

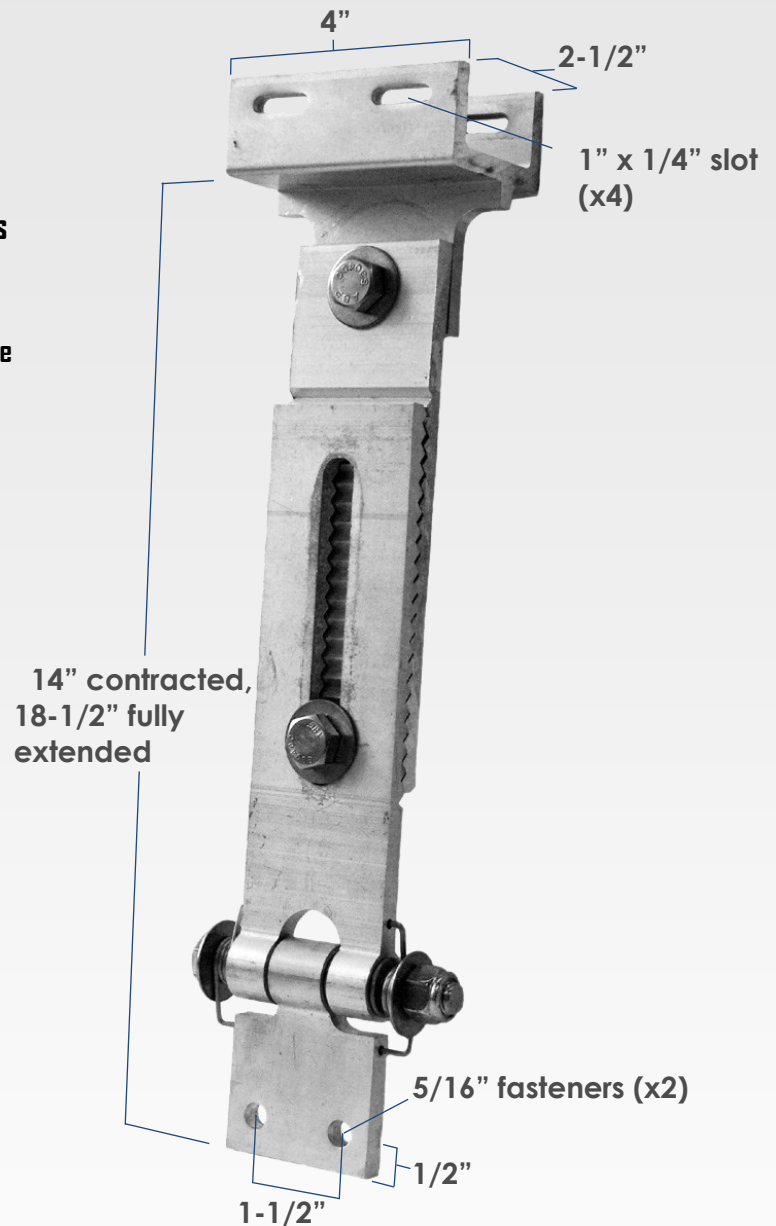

7-OM-A-4 Fastener Options

'SS' = Stainless Steel

7-OM-A-4

- includes no fasteners (we can even offer fasteners not listed in our catalogue)

7-OM-A-4-SS

- HEX HEAD BOLT, SS, 5/16"-18UNC X 1.5" (x2)
- HEX LOCK NUT, SS, 5/16"-18UNC (x2)
- FLAT WASHER, SS, 5/16"ID X 0.75"OD (x4)
- FLAT WASHER, NL, 5/16"ID X 0.75"OD (x2)



Dyna Engineering Ltd.
info@dynaengineers.com

dynaengineering.com

7-OM-F-2.5

OVERHEAD MNT, FIXED LENGTH, 2.5" BASE, SPRING (OPTIONAL)
Mounts to 2-3/8"+ round posts, 2-1/2+ square posts and all lamp standards

Commonly used throughout North America · Backed by a one-year manufacturer warranty

Product Specifications:

- Extruded aluminum, will not rust, 100% recyclable
- Mill finish
- Also available in a powder coated or painted finish
- Slot-free design is compatible with all sign thicknesses
- Features Windless® design:
 - ▶ Built to relieve stress on posts and signs even in extreme winds
 - ▶ Can easily convert to free-swing by removing springs
- Pre-assembled for convenience with stainless steel hardware
- 7-ADAPTER-5-1 available for sign box mounting
- Strap to post
- Bolt thru sign mounting

Testing Specifications:

- Post mounting fasteners tested at 100 in-lbs torque
- Sign mounting fasteners tested at 100 in-lbs torque
- Typically used with grade 18/8 fasteners

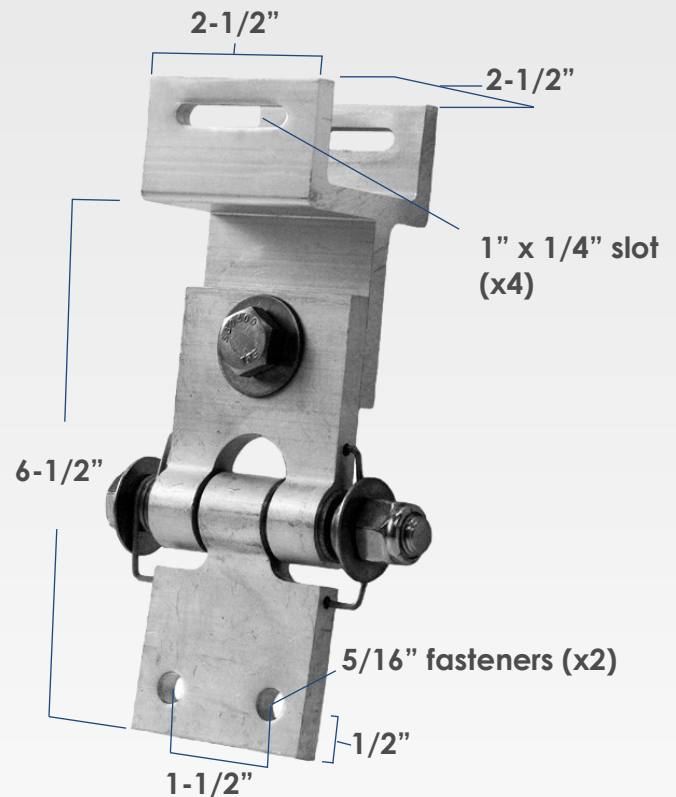

7-OM-F-2.5 Fastener Options

'SS' = Stainless Steel

7-OM-F-2.5

- includes no fasteners (we can even offer fasteners not listed in our catalogue)

7-OM-F-2.5-SS

- HEX HEAD BOLT, SS, 5/16"-18UNC X 1.5" (x2)
- HEX LOCK NUT, SS, 5/16"-18UNC (x2)
- FLAT WASHER, SS, 5/16"ID X 0.75"OD (x4)
- FLAT WASHER, NL, 5/16"ID X 0.75"OD (x2)



Dyna Engineering Ltd.
info@dynaengineers.com

dynaengineering.com

7-OM-F-4

OVERHEAD MNT, FIXED LENGTH, 4" BASE, SPRING (OPTIONAL)
Mounts to 2-3/8"+ round posts, 2-1/2+ square posts and all lamp standards

Commonly used throughout North America · Backed by a one-year manufacturer warranty

Product Specifications:

- Extruded aluminum, will not rust, 100% recyclable
- Mill finish
- Also available in a powder coated or painted finish
- Slot-free design is compatible with all sign thicknesses
- Features Windless® design:
 - ▶ Built to relieve stress on posts and signs even in extreme winds
 - ▶ Can easily convert to free-swing by removing springs
- Pre-assembled for convenience with stainless steel hardware
- 7-ADAPTER-5-1 available for sign box mounting
- Strap to post
- Bolt thru sign mounting

Testing Specifications:

- Post mounting fasteners tested at 100 in-lbs torque
- Sign mounting fasteners tested at 100 in-lbs torque
- Typically used with grade 18/8 fasteners

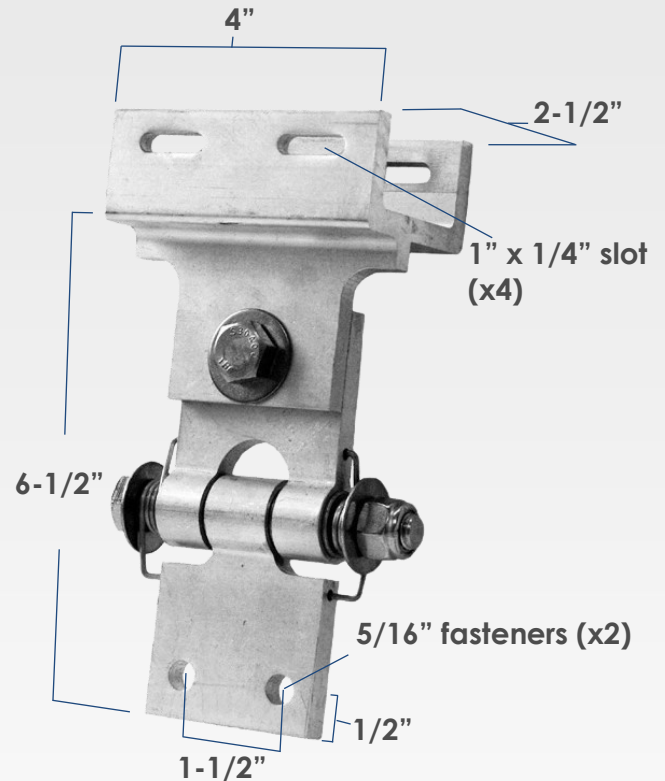

7-OM-F-4 Fastener Options

'SS' = Stainless Steel

7-OM-F-4

- includes no fasteners (we can even offer fasteners not listed in our catalogue)

7-OM-F-4-SS

- HEX HEAD BOLT, SS, 5/16"-18UNC X 1.5" (x2)
- HEX LOCK NUT, SS, 5/16"-18UNC (x2)
- FLAT WASHER, SS, 5/16"ID X 0.75"OD (x4)
- FLAT WASHER, NL, 5/16"ID X 0.75"OD (x2)



Dyna Engineering Ltd.
info@dynaengineers.com

dynaengineering.com