

# FB-021

CTR MNT, FLARED LEG, SS, 4"+ POST, STRAP-ON

Mounts to 4"+ round posts, 2-1/2"+ square posts and all lamp standards

Commonly used throughout North America · Backed by a one-year manufacturer warranty

## Product Specifications:

- Stainless steel, will not rust, 100% recyclable
- Vibratory polished to a low sheen
- Flared stand-off legs for mounting to larger surfaces
- Strap to post
- Bolt thru sign mounting

## Testing Specifications:

- Sign mounting fasteners tested at 100 in-lbs torque
- Tested with grade 18/8 fasteners

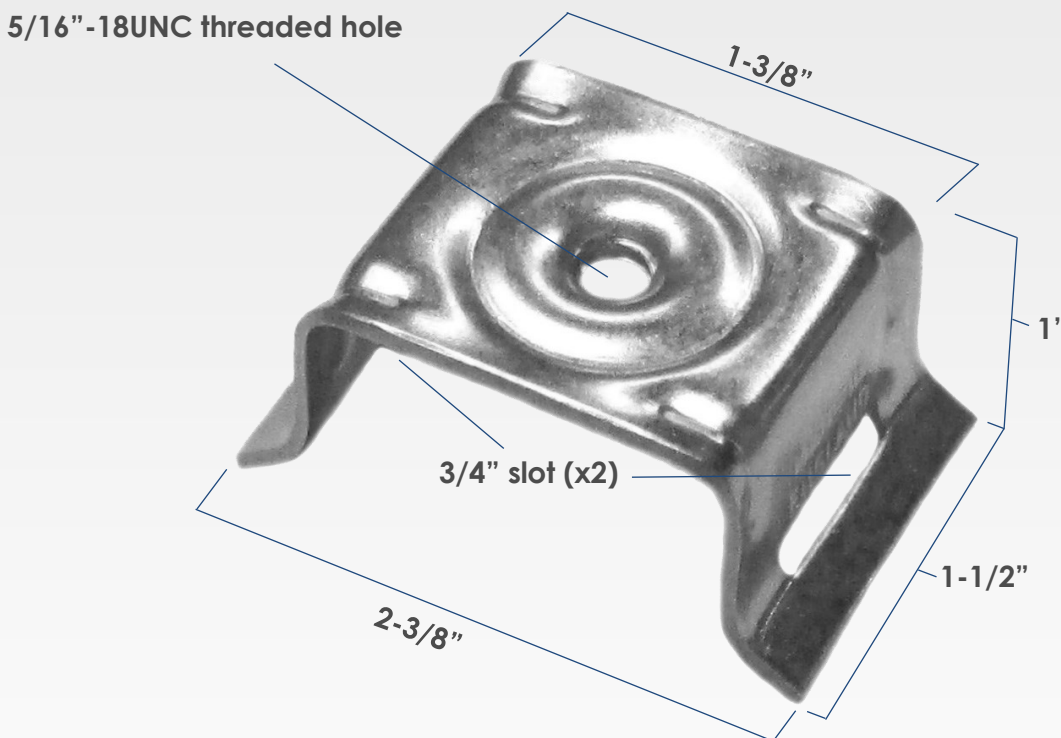

## FB-021 Fastener Options

'ZP' = Zinc Plated / 'SS' = Stainless Steel

### FB-021

- includes no fasteners (we can even offer fasteners not listed in our catalogue)

### FB-021-SS-PB

- HEX HEAD BOLT, SS, 5/16"-18UNC X 0.625" (x1)
- FLAT WASHER, SS, 5/16"ID X 0.75"OD (x1)
- FLAT WASHER, NL, 5/16"ID X 0.75"OD (x1)



**Dyna Engineering Ltd.**  
info@dynaengineers.com

[dynaengineering.com](http://dynaengineering.com)

# D022

CTR MNT, FLARED LEG, SS, 4"+ POST, STRAP-ON  
Mounts to 4"+ round posts, 2-1/2"+ square posts and all lamp standards

Commonly used throughout North America · Backed by a one-year manufacturer warranty

## Product Specifications:

- Stainless steel, will not rust, 100% recyclable
- Vibratory polished to a low sheen
- Flared stand-off legs for mounting to larger surfaces
- Strap to post
- Bolt thru sign mounting

## Testing Specifications:

- Sign mounting fasteners tested at 100 in-lbs torque
- Tested with grade 18/8 fasteners

5/16"-18UNC threaded hole

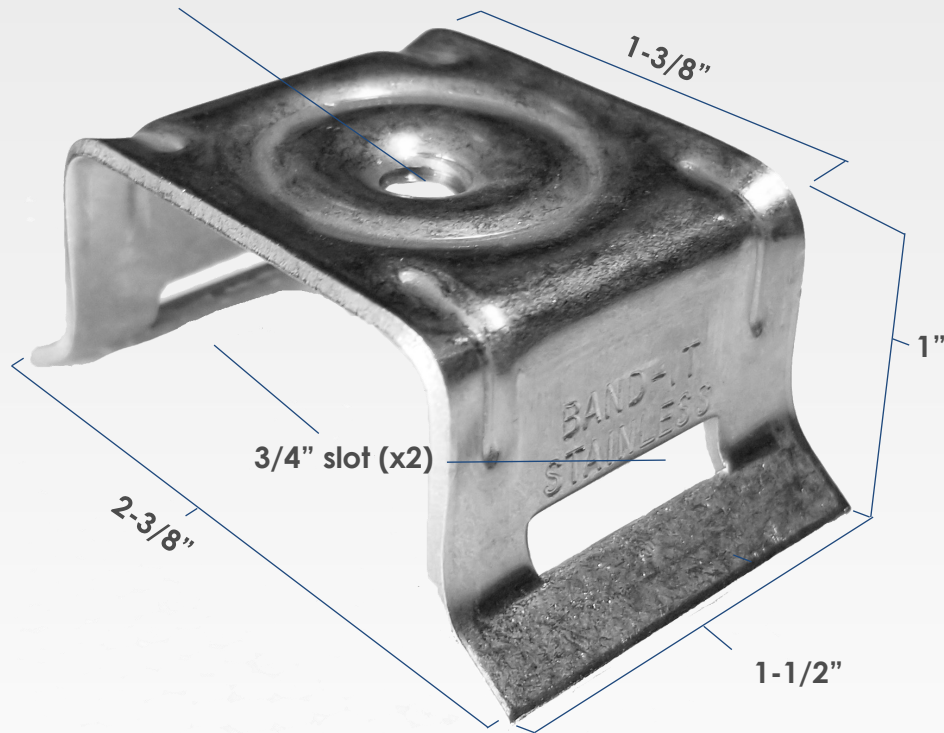

## D022 Fastener Options

'ZP' = Zinc Plated / 'SS' = Stainless Steel

### D022

- includes no fasteners (we can even offer fasteners not listed in our catalogue)

### D021

- HEX HEAD BOLT, SS, 5/16"-18UNC X 0.625" (x1)
- FLAT WASHER, SS, 5/16"ID X 0.75"OD (x1)
- FLAT WASHER, NL, 5/16"ID X 0.75"OD (x1)



**Dyna Engineering Ltd.**  
info@dynaengineers.com

[dynaengineering.com](http://dynaengineering.com)