

No.	DESCRIPCION	CODIGO	CANT.	I.S./100
1	SUBENSAMBLE PORTACARRO	M570829	1	2
2	BARRA PARA PISON 1/2" AMS-350	M571161	1	2
3	RESORTE PARA TOPE DEL PISON AI INFERIOR Y SUPERIOR	M501545	2	2
4	MANIJA PARA DESPLAZAR CARRO AMS-350	M503849	1	2
5	AGARRADERA DE PISON AMS-350	M571182	1	2
6	SOPORTE EMPUJA PRODUCTO AMS-350	M571187	1	2
7	PERNO PARA SOPORTE EMPUJA PRODUCTO	M571188	1	2
8	SUBENSAMBLE VARILLA EMPUJA PRODUCTO (VARILLAYPLACA)	M571191	1	1
9	SUBENSAMBLE BRAZO DE PISON AMS-350	M570703	1	2
10	SUBENSAMBLE PISON	M570729	1	2
11	BARRA DE EMPUJADOR DE PRODUCTO	M572481	1	1
12	GANCHO DE PISON	M571008	1	2

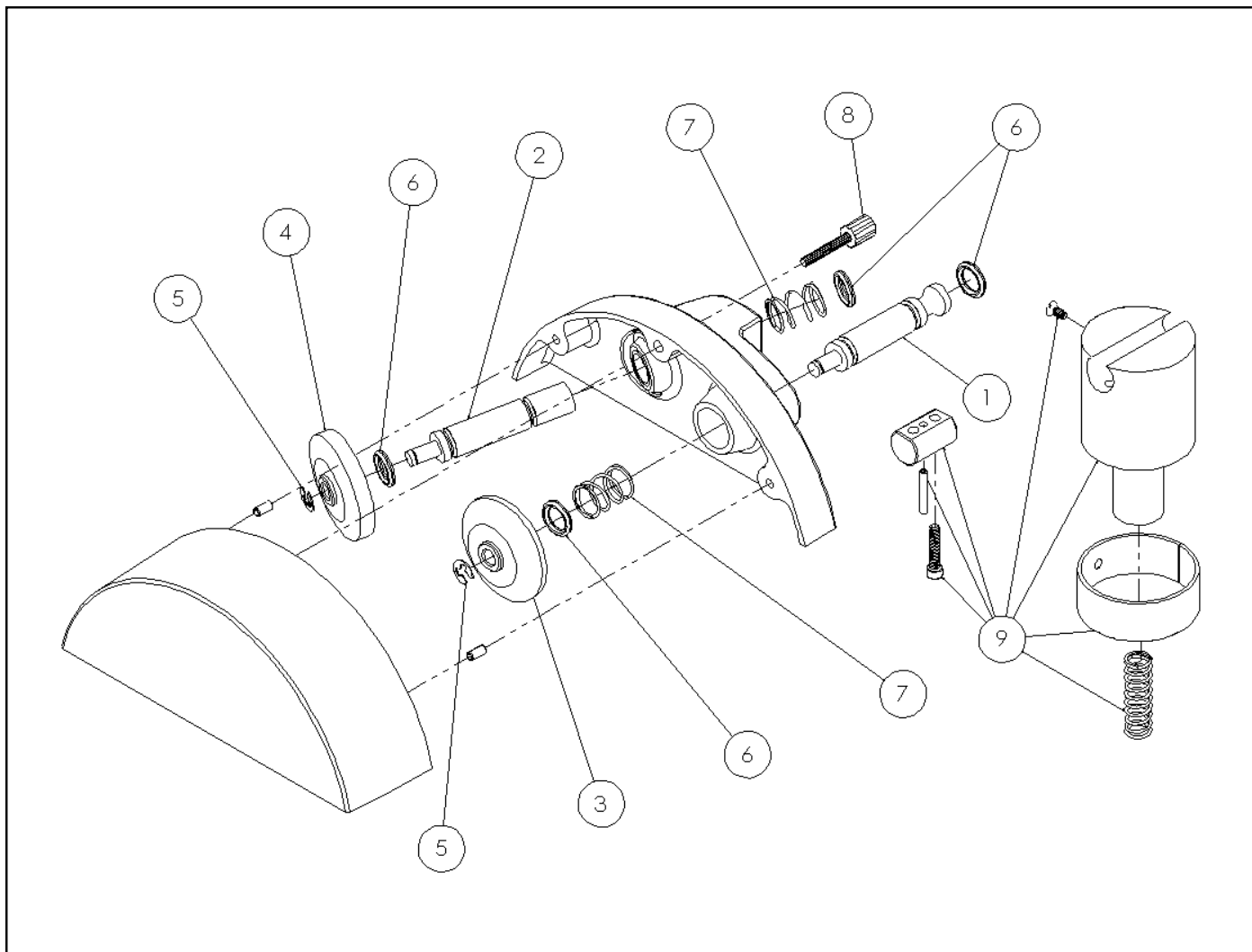

No.	DESCRIPCION	CODIGO	CANT.	I.S./100
1	FLECHA PARA PIEDRA DE ACENTAR	M571195	1	2
2	FLECHA PARA PIEDRA DE AFILAR	M571196	1	2
3	PIEDRA PARA ACENTAR	M502176	1	10
4	PIEDRA PARA AFILAR	M502177	1	10
5	CANDADOS 5133-31	M500280	2	2
6	EMPAQUES O-RING #2-212	M500388	8	2
7	RESORTES PARA FLECHAS DE ACENTAR Y AFILAR A.I.	M501544	2	2
8	PERILLA P/AFILADOR SUBENS. (REF)	M572990	1	2
9	SUBENSAMBLE SOPORTE AFILADOR	M570830	1	2
	AFILADOR SUBENSAMBLE	M571192	1	2

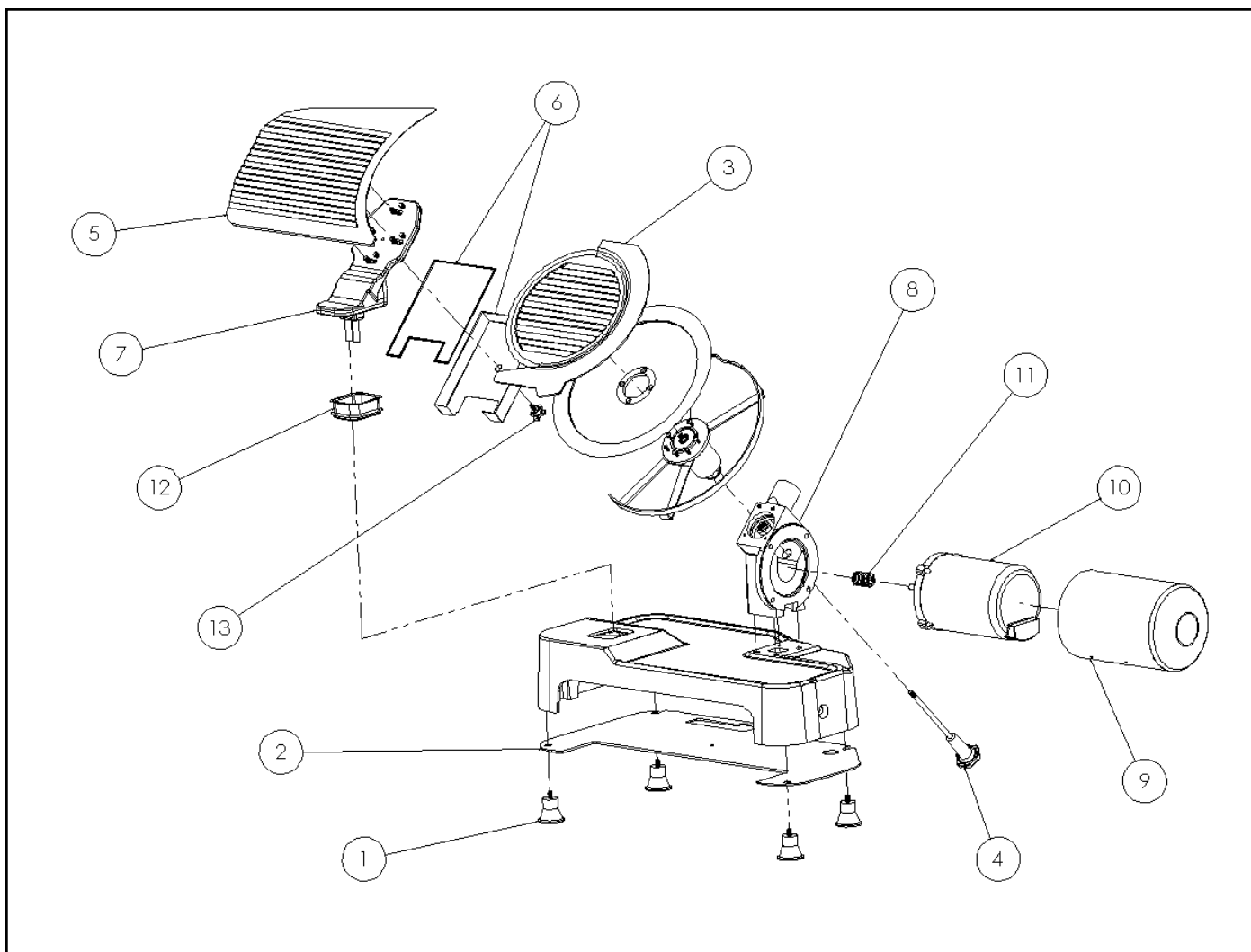

No.	DESCRIPCION	CODIGO	CANT.	I.S./100
1	PATA PARA AMS-350	M504067	4	2
2	TAPA INFERIOR DE BASE AMS-350	M571120	1	2
3	PLATO AMS-350 ANODIZADO	M571155	1	2
4	PERILLA PARA PLATO INYECTADA	M532908	1	2
5	PLANCHA AMS-350 ANODIZADA	M571204	1	2
6	SUBENSAMBLE CUBIERTA PORTAPLANCHA	M570837	1	2
7	KIT PARA PORTAPLANCHA-AMS-350	M570702	1	2
8	REDUCTOR RMS-330 MAQ. Y ANODIZADO	M571136	1	2
9	CUBREMOTOR	M571151	1	2
10	MOTOR WEG 1/2 HP, BRIDA "C"	M506926	1	2
11	SINFÍN 6 ENTRADAS GENERADO Y TEMPLADO	M571152	1	4
12	EMPAQUE PARA PORTAPLANCHA	M504551	1	3
13	PERILLA P/PROTECTOR PORTAPLANCHA AMS-350	M504550	1	2

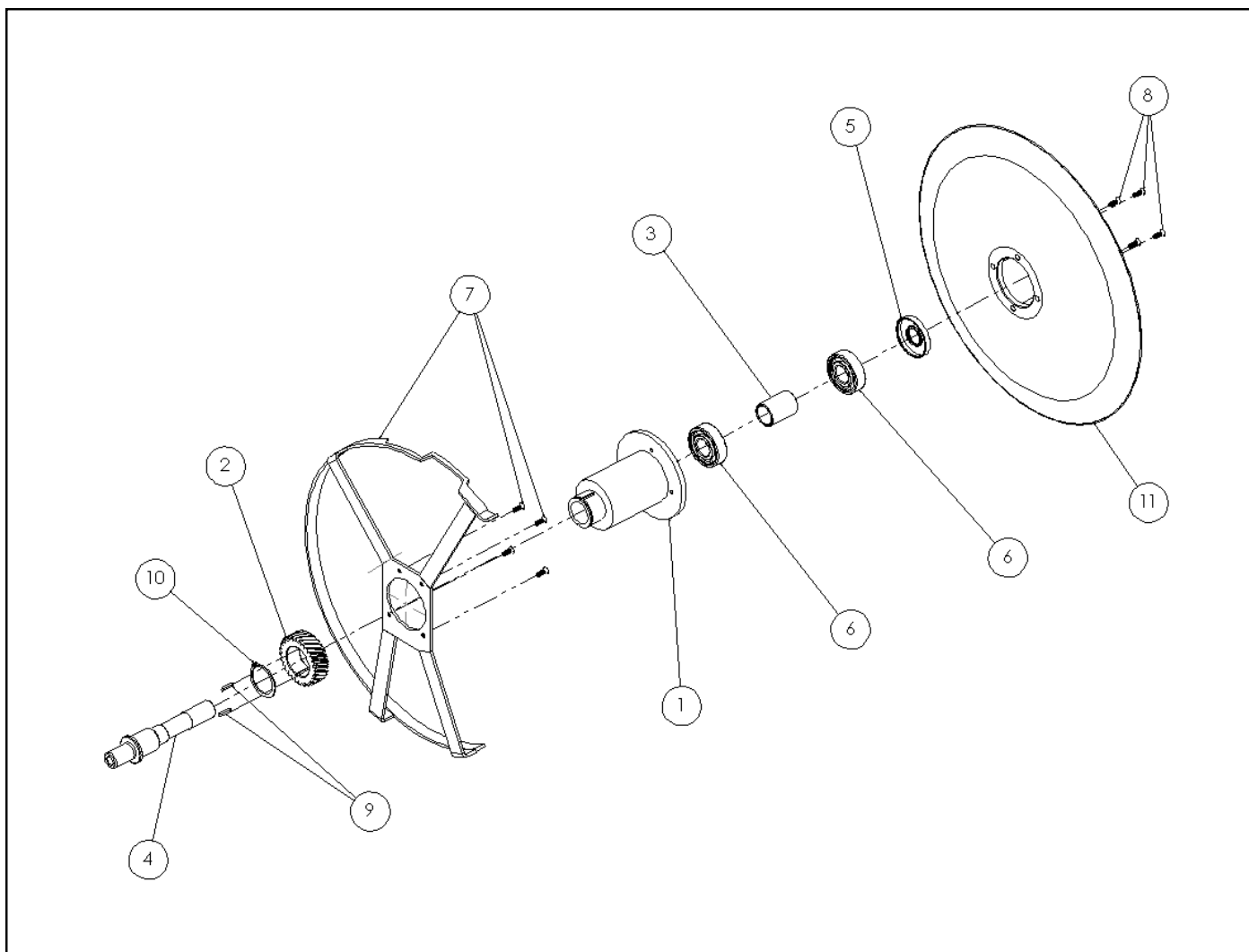

No.	DESCRIPCION	CODIGO	CANT.	I.S./4100
1	CAMPANA RMS-330 MAQUINADA	M571138	1	2
2	CORONA DE NYLAMID	M570400	1	4
3	SEPARADOR DE BALEROS MAQUINADO	M571140	1	2
4	FLECHA PARA BALEROS	M571141	1	2
5	RETEN PARA CAMPANA	M503010	1	2
6	BALERO #6204	M503387	2	2
7	KIT PROTECTOR DE CUCHILLA AMS-350	M570704	1	2
8	TORNILLO PLANO NO. 8-32 X 1/2 GR82 INOX.	M501471	4	10
9	CUÑA DE 1/8 X 1/8 X 5/8"	M570132	2	2
10	CANDADO # 5100-137	M500279	1	2
11	CUCHILLA SÓLIDA 350MM DIA. (AMS-350)	M504554	1	2

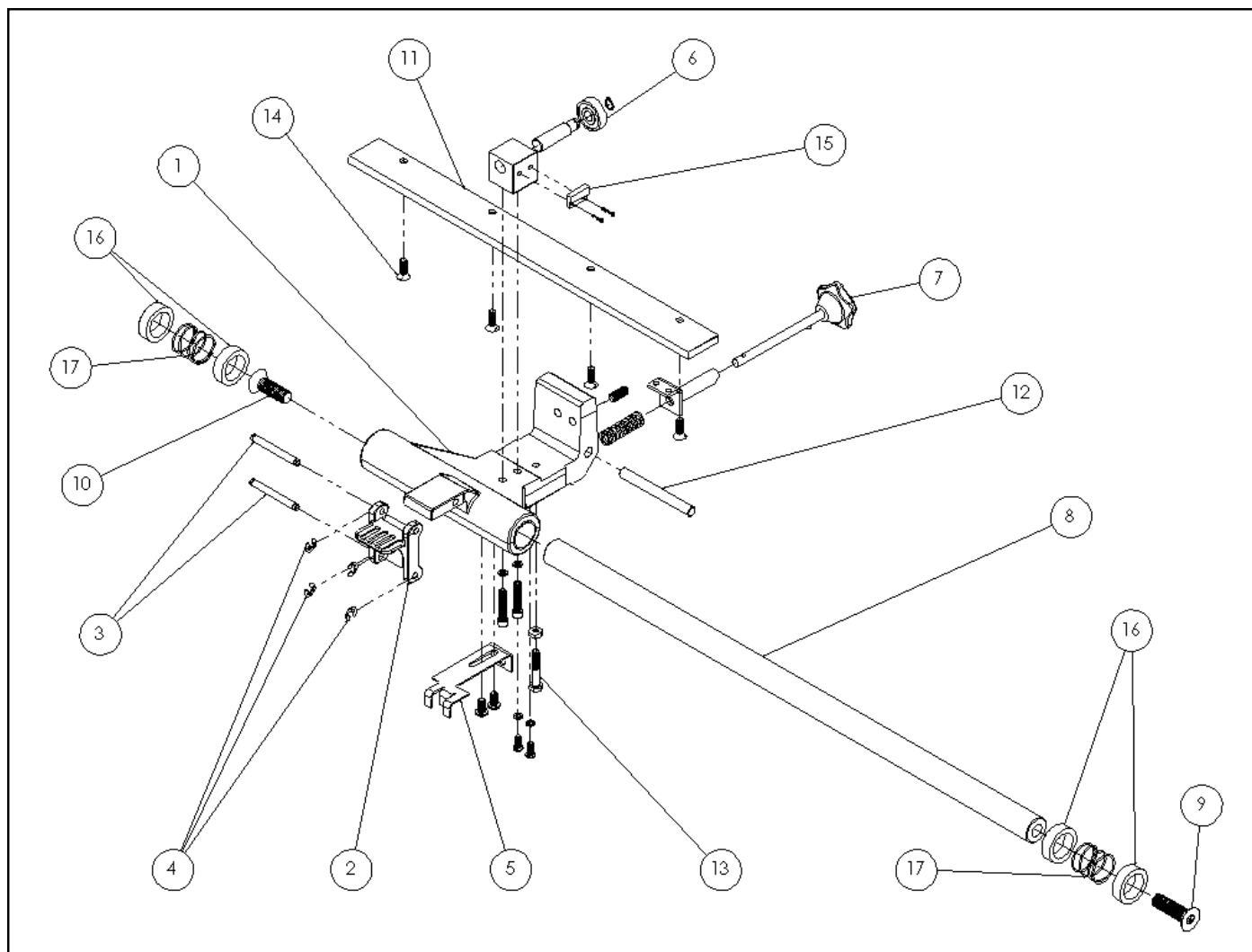

No.	DESCRIPCION	CODIGO	CANT.	I.S./100
1	SUBENSAMBLE BUJE DESLIZADOR	M570828	1	2
2	CLAMP PARA BANDA MAQUINADO AMS-350	M571209	1	2
3	PERNO PARA BISAGRA AMS-350	M571210	2	1
4	CANDADO RETENCION EXTERNA 1/4"	M504545	4	2
5	PLACA NIVELADORA AUT-MANUAL	M571212	1	2
6	BALERO 6000 2RS KML	M503381	1	7
7	PERILLA PARA SISTEMA AUTOMANUAL AMS-350	M571214	1	2
8	BARRA DE DESLIZAMIENTO AMS-350	M571216	1	2
9	TORNILLO CABEZA PLANA HEX 1/2-13 UNC -1.7"	M501785	1	2
10	TORNILLO CABEZA PLANA HEX 1/2-13 UNC -1.5"	M501784	1	2
11	PISTA DESLIZADORA AMS-350 GALVANIZADA	M571218	1	1
12	PERNO BISAGRA 3/8" INOX	M570895	1	2
13	TORNILLO C/HEX. COBRE 1/4-20 UNC X 1 1/2"	M504597	1	4
14	TORNILLO CAB. PLANA 1/4 - 20 UNC 3/4" GALV.	M504555	4	1
15	ACTUADOR MAGNÉTICO HAMLIN (57140-000)	M506909	1	4
16	TOPE DE HULE P/BARRA R-300A Y ST-355	M500336	4	8
17	RESORTE P/BARRA DE BUJE LARGO R-300A	M501543	2	4
	SUBENSAMBLE BUJE DESLIZADOR COMPLETO	M570458	1	2

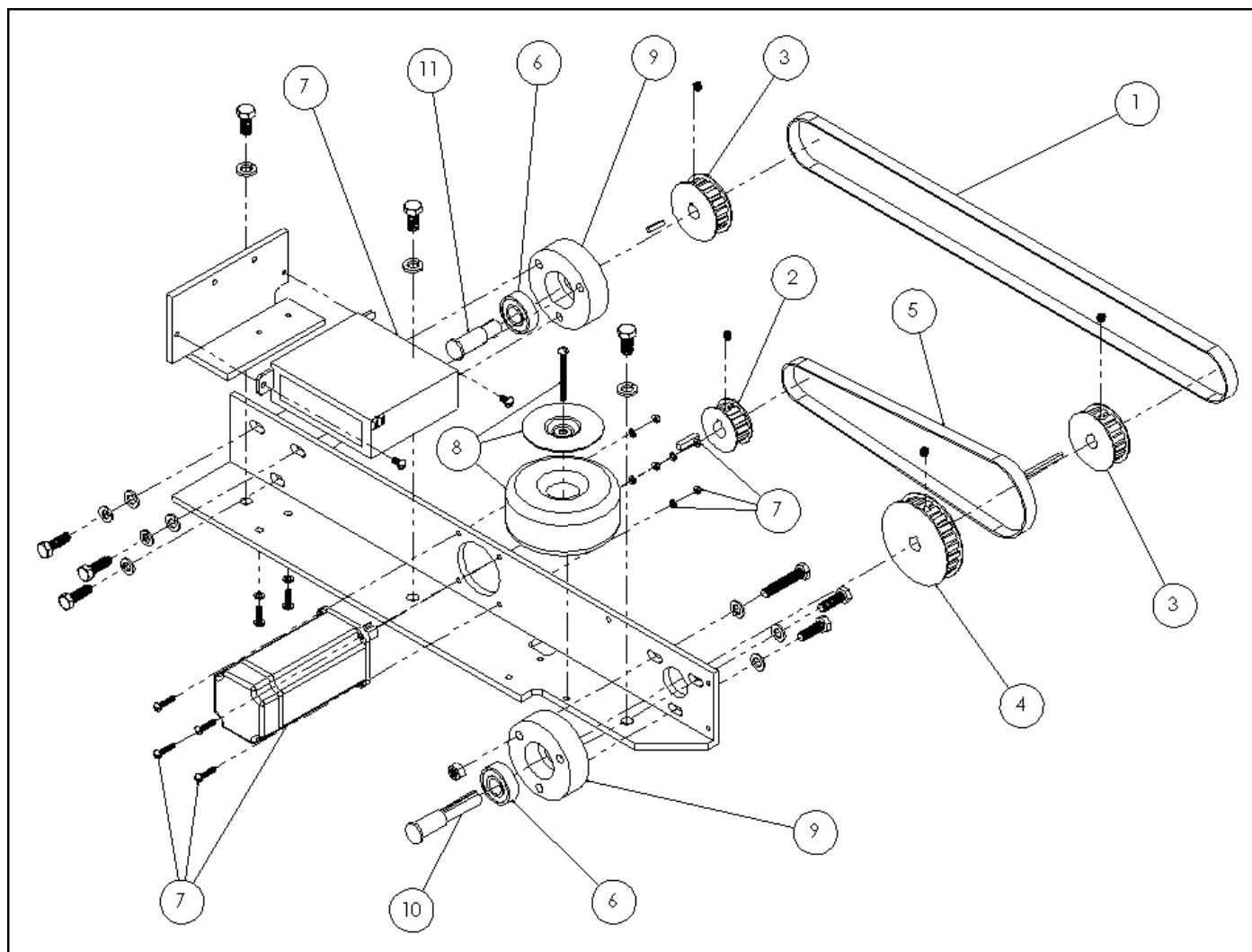

No.	DESCRIPCION	CODIGO	CANT.	I.S./100
1	BANDA 439MM LARGO, PASO 9.5MM, 1/2 ANCHO	M504566	1	4
2	POLEA 12	M571145	1	2
3	POLEA 16	M571146	2	2
4	POLEA 24	M571147	1	2
5	BANDA 255MM LARGO, PASO 9.5MM, 1/2 ANCHO	M504565	1	5
6	BALERO #6202 PEER BEARING	M503384	2	6
7	SUBENSAMBLE SERVO-DRIVER-AMS-350	M570730	1	2
8	TRANSFORMADOR TOROIDAL 115/220 VAC, 250VA	M504523	1	2
9	SOPORTE DE BALERO POLEAS AMS-350	M572537	2	2
10	FLECHA POLEA 24 Y 16	M572495	1	2
11	FLECHA POLEA 16	M572494	1	2
	SUBENSAMBLE TRANSMISION DE POLEAS	M570768	1	2

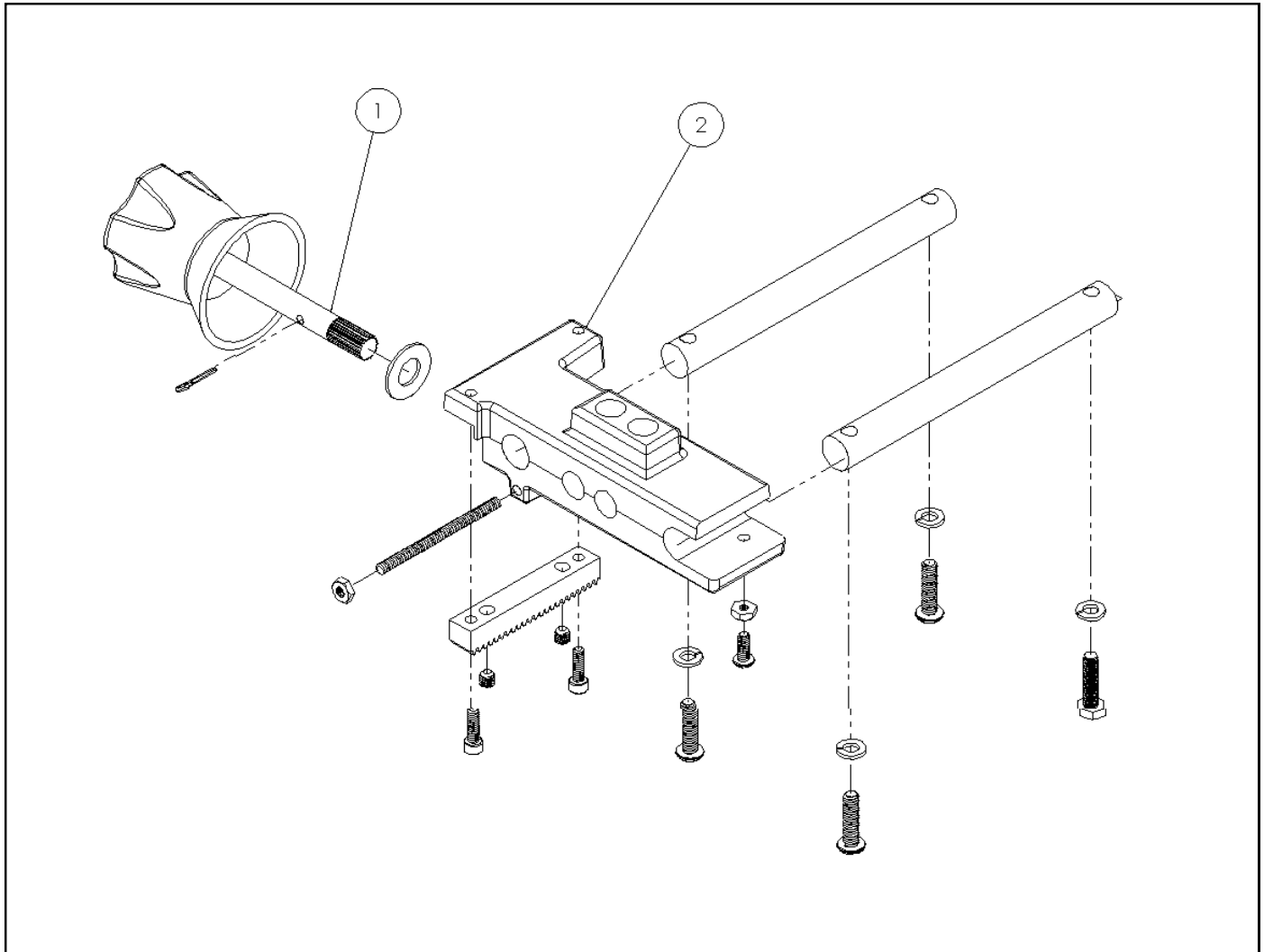

No.	DESCRIPCION	CODIGO	CANT.	I.S./100
1	KIT PERILLA REGULADORA AMS-350	M570725	1	2
2	KIT REGULADOR DE CORTE-AMS-350	M570724	1	2

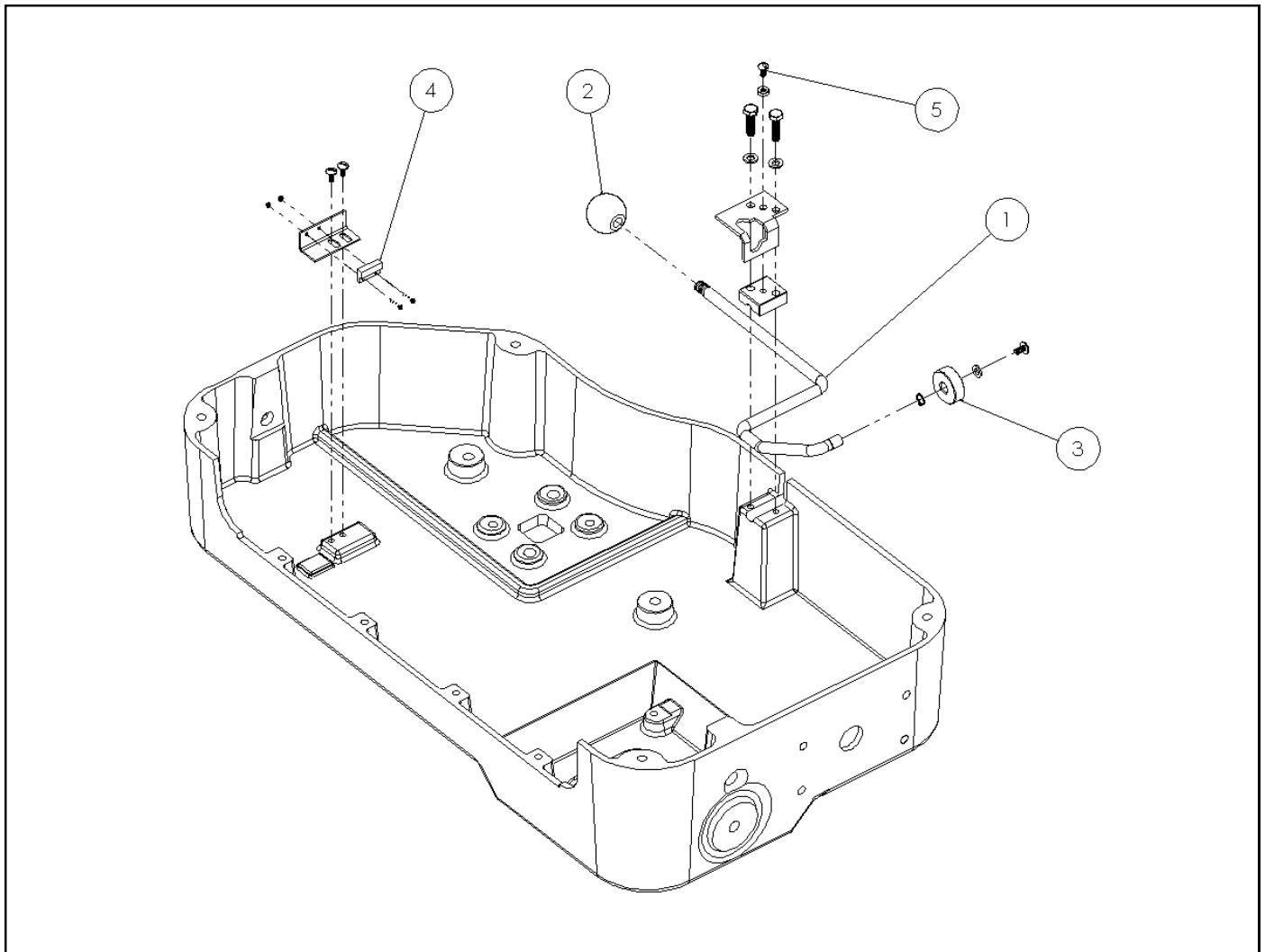

No.	DESCRIPCION	CODIGO	CANT.	I.S./100
1	PALANCA LEVANTA MAQUINA AMS-350	M571219	1	2
2	MANIJA DE PALANCA AMS-350	M504548	1	2
3	RUEDA PARA PALANCA AMS-350	M571221	1	2
4	SUBENSAMBLE SENSOR CERO	M570726	1	4
5	TORNILLO CAB. GOTA 3/16 X 3/8" LATON	M506882	1	3
	SUBENSAMBLE PALANCA LEVANTA MAQUINA (1,2,3,5)	M570645	1	2

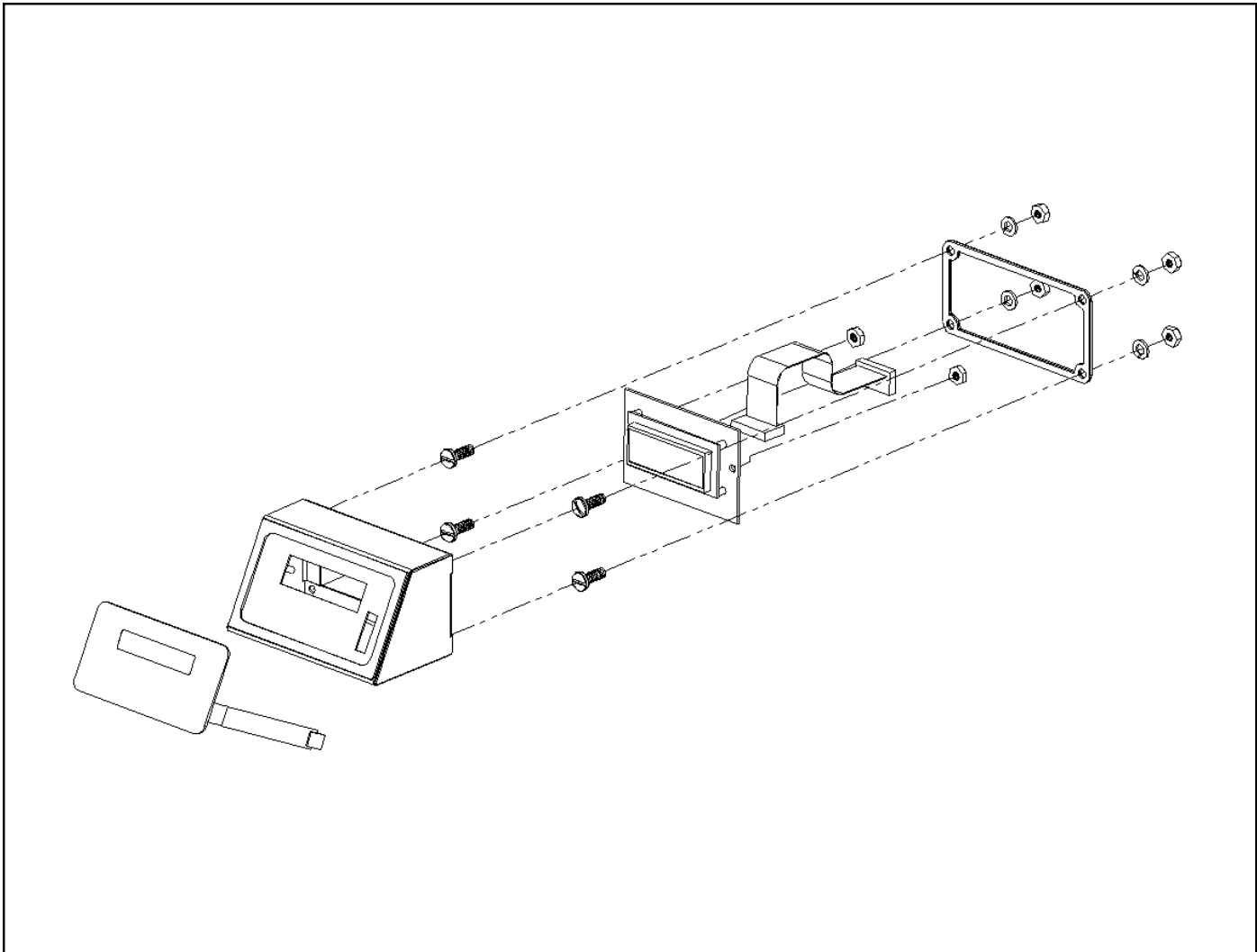

No.	DESCRIPCION	CODIGO	CANT.	I.S./100
1	SUBENSAMBLE PANEL DE CONTROL	M570834	1	2