



PROJECT NAME	LOCATION		AIA #
ITEM #	QTY	MODEL #	SIS #

SPEC SERIES®

REACH-IN SOLID HALF SWING DOOR DUAL TEMPERATURE REFRIGERATOR/FREEZER WITH HYDROCARBON REFRIGERANT

models	STR1DT-2HS-HC	STA1DT-2HS-HC	STG1DT-2HS-HC
--------	---------------	---------------	---------------



STR1DT-2HS-HC	
Exterior	Stainless steel door, front & sides.
Interior	Stainless steel side walls, back, floor, door liner, & ceiling.
Shelving	(1) Interior kit option included per full section.

STA1DT-2HS-HC	
Exterior	Stainless steel door, front & sides.
Interior	Aluminum side walls & back. Stainless steel floor & ceiling.
Shelving	(3) Heavy duty, chrome plated, wire shelves per section.

STG1DT-2HS-HC	
Exterior	Stainless steel door, with matching aluminum sides.
Interior	Aluminum side walls & back. Stainless steel floor & ceiling.
Shelving	(3) Heavy duty, PVC coated, wire shelves per section.

SPECIFICATIONS		
Dimensions	in.	mm.
Length	27 ¹ / ₂	699
Depth	33 ³ / ₄	858
Height	77 ³ / ₄	1975
Electrical	U.S.	International
HP Refrigerator	1/10	N/A
HP Freezer	1/4	N/A
Amps	3.7	N/A
Voltage	115/60/1	N/A
NEMA	5-15P	N/A
Cord Length	9 ft.	2.74 M.
115/60/1 NEMA-5-15R		
* Height does not include 6 ¹ / ₈ " (156 mm) for castors or 6" (153 mm) for optional legs. Height does not include 1/4" (7mm) for system mechanical components. † Depth does not include 1 1/2" for door handle.		

plan view

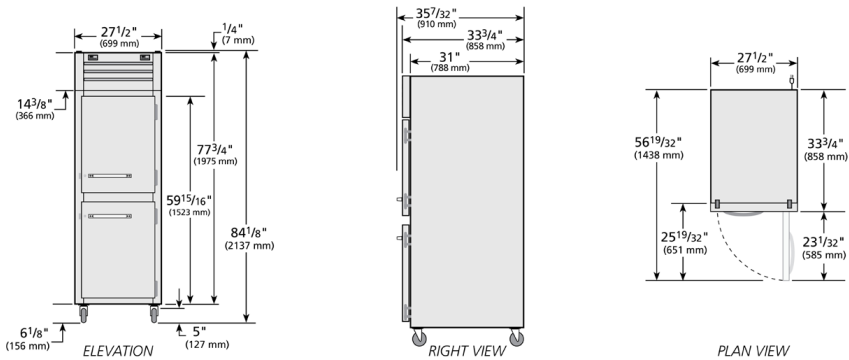

Specifications subject to change without notice.
 Chart dimensions are rounded up to the nearest 1/8" (millimeters rounded up to the next whole number).



PROJECT NAME	LOCATION	AIA #
ITEM #	QTY	MODEL #
		SIS #

SPEC SERIES®

REACH-IN SOLID HALF SWING DOOR DUAL TEMPERATURE REFRIGERATOR/FREEZER WITH HYDROCARBON REFRIGERANT

models	STR1DT-2HS-HC	STA1DT-2HS-HC	STG1DT-2HS-HC
--------	---------------	---------------	---------------



standard features

REFRIGERATION SYSTEM

- Equipped with two, independent, factory engineered, self-contained, capillary tube refrigeration systems using environmentally friendly environmentally friendly R290 hydrocarbon refrigerant that has zero (0) ozone depletion potential (ODP), & three (3) global warming potential (GWP).
- Refrigerator located in top section; freezer on bottom.
- High capacity, factory balanced refrigeration system that maintain colder standard temperatures for the best in food preservation. Refrigerator holds 33°F to 38°F (.5°C to 3.3°C); freezers holds -10°F (-23.3°C).
- State of the art, electronically commutated evaporator and condenser fan motors. ECM motors operate at higher peak efficiencies and move a more consistent volume of air which produces less heat, reduces energy consumption and provides greater motor reliability.
- Top mounted refrigeration system with evaporator positioned out of food zone to maximize capacity.
- Freezer features automatic defrost system, time-initiated, time-terminated.
- Automatic evaporator fan motor delay during defrost cycle.

CABINET CONSTRUCTION

- Insulation - entire cabinet structure and solid door are foamed-in-place using a high density, polyurethane insulation that has zero ozone depletion potential (ODP) and zero global warming potential (GWP).
- 5" (127 mm) diameter plate castors - locks provided on front set.

DOORS

- Lifetime guaranteed bolt style door locks standard.
- Lifetime guaranteed heavy duty all metal working door handles.
- Positive seal self-closing doors with 120° stay open feature. Lifetime guaranteed external cam lift door hinges, four (4) per door section.
- Magnetic door gaskets of one piece construction, removable without tools for ease of cleaning.

LIGHTING

- LED interior lighting, safety shielded.

MODEL FEATURES

- Two (2) exterior digital temperature displays, one for refrigerator section and one for freezer.
- Evaporator epoxy coated to eliminate the potential of corrosion
- Curb mounting ready.
- NSF/ANSI Standard 7 compliant for open food product.

ELECTRICAL

- Unit completely pre-wired at factory and ready for final connection to a 115/60/1 phase, 15 amp dedicated outlet. Cord and plug set included.

OPTIONAL FEATURES/ ACCESSORIES

(upcharge & lead times may apply)

- 6" (153 mm) standard legs.
- 6" (153 mm) seismic/flanged legs.
- 6" (153 mm) stainless steel legs.
- Field reversible hinge.
- Additional shelves.
- Stainless back. (STR, STA, STG)
- Security package.
- Freezer on top section model available "STR1DTA-2HS-HC".

SHELVING KIT OPTIONS

- STR series kits factory installed at no charge. STA & STG series kits field installed, upcharge applies, lead times may apply.
- Kit #1: Nine (9) sets of #1 type tray slides and pilasters (field installed), bottom support of one (1) 18"L x 26"D (458 mm x 661 mm) pan or two (2) 14"L x 18"D (356 mm x 458 mm) pans.
- Kit #2: Not available for this model.
- Kit #3: Six (6) sets of universal type tray slides and pilasters (field installed), bottom support of one (1) 18"L x 26"D (458 mm x 661 mm) pan, two (2) 14"L x 18"D (356 mm x 458 mm) pans or two (2) 12"L x 20"D (305 mm x 508 mm) pans.
- Kit #4: Three (3) chrome shelves 26 5/16"L x 21 5/16"D (669 mm x 548 mm). Optional wall mounted shelf support pilasters (field installed) with four (4) shelf clips per shelf available; adjustable on 1/2" (13 mm) increments (must order at time of cabinet order).
- Additional kit option components available individually.

3 YEAR PARTS + LABOR
7 YEAR COMPRESSOR
WARRANTY
 (U.S.A. and Canada only)

METRIC DIMENSIONS ROUNDED UP TO THE NEAREST WHOLE MILLIMETER
 SPECIFICATIONS SUBJECT TO CHANGE WITHOUT NOTICE



Model	Elevation	Right	Plan	3D	Back
ST()1DT-2HS-HC					