



Project _____

AIA# _____ SIS# _____

Item # _____ Quantity _____

HEAVY DUTY SERIES

Turbo Gas Fryers



Model TURBO 30-5Q

The images presented here are illustrative and may vary or not exactly match the physical product.



MODELS

TURBO 25.5-4Q

TURBO 30-5Q

STANDARD FEATURES

- External and internal sheet metal parts in stainless steel.
- 16 gauge stainless steel tank.
- Cold zone that extends oil life.
- Nickel plated baskets with plastic coated handles.
- 23,000 Btu/h cast burners.
- Snap action thermostat, 212 - 400°F (100 - 204°C) temperature range.
- Safety millivolt valve.
- Automatic high temperature limit control, calibrated to 450°F (232°C).
- Cold zone that extends oil life.
- 1 1/4" Ø ball type drain valve.
- Gas pressure regulator.
- Stainless steel adjustable legs.
- CSA design certified, NSF listed.

HEAVY DUTY SERIES - Turbo Gas Fryers

DESCRIPTION

Coriat Heavy Duty Series Turbo Gas Fryers are specially designed as central elements in regular kitchens or as auxiliary devices in very large kitchens. They are perfect for large volume production of french fries, onion rings, tenders, wings and seafood.

SPECIFY TYPE OF GAS WHEN ORDERING

Natural Gas

Propane

SPECIFY ALTITUD

Above 2,000 ft

Approved by _____ Date _____ Approved by _____ Date _____



HEAVY DUTY SERIES

Turbo Gas Fryers

CLEARANCE AND POSITIONING REQUIREMENTS

This product must be installed on a non-combustible surface only, with a minimum of 6" from all sides. There must be a clearance of at least 6" from another appliance. This unit is supplied with 4 legs and must be placed on a resistant non-slip surface.

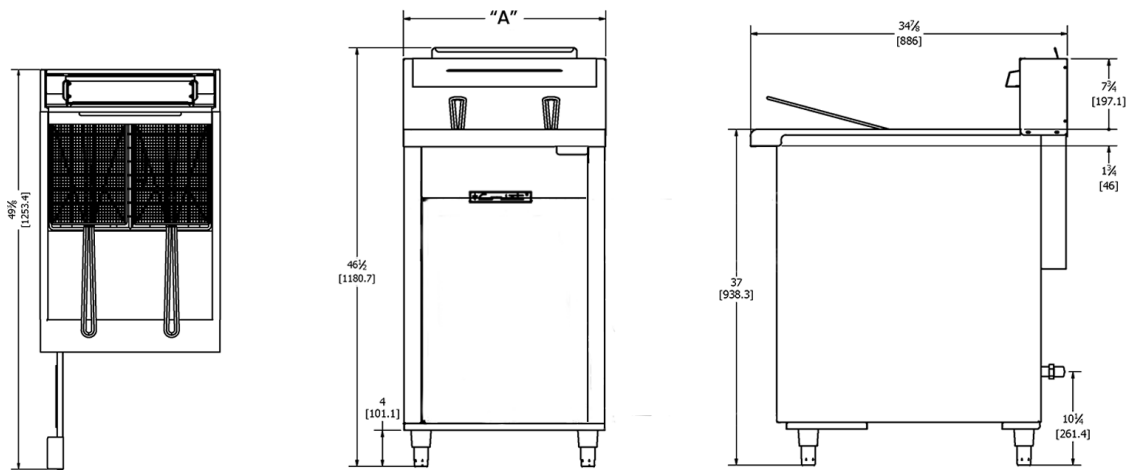

Model	Width (A)	Depth	Overall Height	Working Height	Tank Size	Fry Capacity (lbs)	BTU/HR	Shipping Weight (Lbs/Kg)
TURBO 25.5-4Q	19 1/8"	34 7/8"	46 1/2"	37"	17 1/8" X 14"	50	120,000	203/92
TURBO 30-5Q	22 1/4"	34 7/8"	46 1/2"	37"	20 3/8 X 4"	65	150,000	225/102

Constant improvement in all our processes is a Coriat value, therefore some specifications are subject to change without notice.

Approved by _____ Date _____ Approved by _____ Date _____