

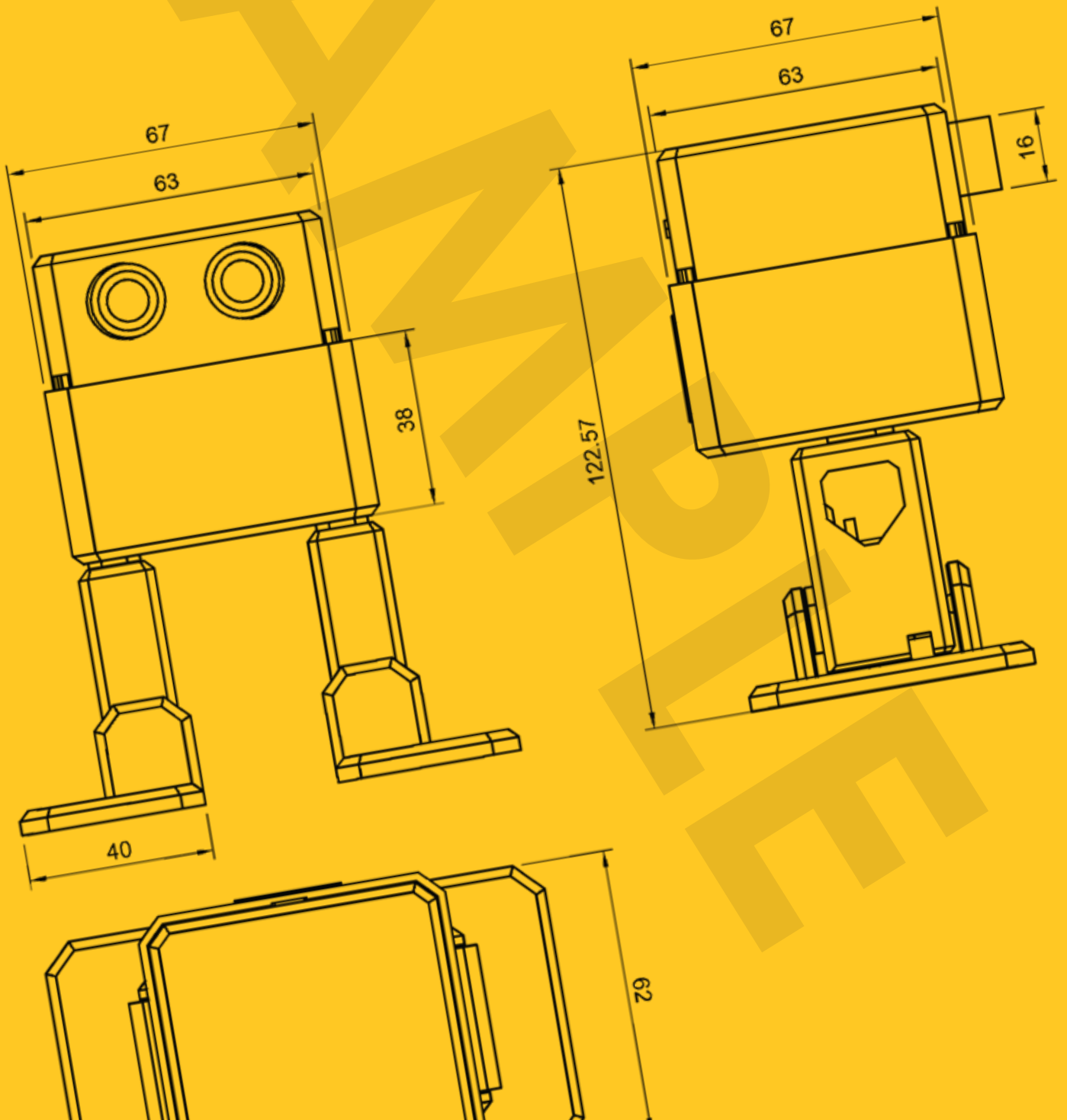

DEPARTMENT OF DESIGN, TECHNOLOGY & ENGINEERING  
**WORKBOOK**



# Attainment

We will break each grade into +/- or just grades to give an indication of where you stand 'within' the band for homework and classwork.

## Level

6  
+ -

- \* A clear understanding of all stakeholder requirements, and strong evidence of an iterative approach to designing and developing
- \* This level will be awarded for a highly developed and outstanding performance in all areas with a confident degree of independent learning
- \* The quality of your work and effort is consistent with attention to detail and presentation
- \* Confident understanding and use of materials, processes and techniques, CAD and CAM
- \* Depth of knowledge and understanding of the work of designers and manufacturers

5  
+ -

- \* A good understanding of key stakeholder requirements
- \* This level will be awarded for a well considered, confident, independent approach
- \* The quality of your work and effort is consistent with attention to detail and presentation
- \* Developing evidence of an iterative approach to designing and developing
- \* Confident use of materials, processes and techniques, CAD and CAM
- \* Knowledge and understanding of the work of other designers and manufacturers

4  
+ -

- \* Some understanding of key stakeholder requirements
- \* This level will be awarded for a competent and well considered approach
- \* The quality of your work and effort is consistent with attention to detail and presentation
- \* Evidence of an iterative in design and/or development
- \* Developing confidence in using materials, processes and techniques, CAD and CAM
- \* Your work shows evidence of knowledge and understanding of the work of other designers and manufacturers.

3  
+ -

- \* Little evidence of stakeholder requirements
- \* This level will be awarded for a considered and consistent approach
- \* Developing confidence in using materials, processes and techniques, CAD and CAM
- \* Aim to focus more on iteration at the design or development stage
- \* You will show some knowledge and understanding of the work of other designers and manufacturers
- \* Consider the presentation of your work more carefully

2  
+ -

- \* No evidence of stakeholder requirements
- \* This level will be awarded for a considered and appropriate response
- \* A growing confidence in materials, processes and techniques, CAD and CAM
- \* The quality of your work and effort may vary
- \* Aim to focus more on iteration in the ideation stage
- \* Consider the presentation of your work more carefully
- \* You need to spend more time and care on homework and classwork

1  
+ -

- \* No evidence of stakeholder requirements
- \* This level will be awarded for a growing understanding of the task
- \* A growing confidence in materials, processes and techniques, CAD and CAM
- \* The quality of your work and your general effort is unsatisfactory
- \* Focus more on attention to detail, and consider the presentation of your work more carefully
- \* You need to spend more time and care on homework and classwork
- \* There is no evidence of iteration in your work

## My targets

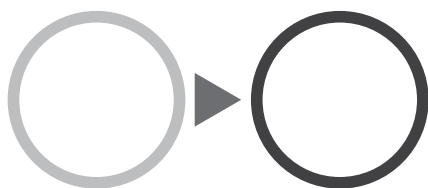

Assessment Date:  
To hit my target I will:

\_\_\_\_\_

\_\_\_\_\_

\_\_\_\_\_

\_\_\_\_\_ achieved

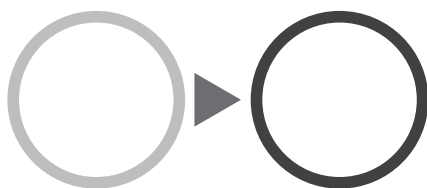

Assessment Date:  
To hit my target I will:

\_\_\_\_\_

\_\_\_\_\_

\_\_\_\_\_

\_\_\_\_\_ achieved



Assessment Date:  
To hit my target I will:

\_\_\_\_\_

\_\_\_\_\_

\_\_\_\_\_

\_\_\_\_\_ achieved

# EFFORT GRADES!

## A OUTSTANDING

- \* Fully focused in lessons contributing to discussion
- \* Work both in class and at home always done to best of ability
- \* Fully equipped for every lesson and always punctual
- \* All deadlines met
- \* Evidence of independent attitude to learning and consolidation of ideas outside class

## B GOOD

- \* Hardworking and attentive in lessons
- \* Work both in class and at home complete and presented to the best of their ability
- \* Fully equipped for every lesson and always punctual
- \* All deadlines met
- \* Evidence of consolidation of ideas outside class and some independent learning
- \* Must never distract others

## C SATISFACTORY

- \* Generally hardworking and attentive in lessons but focus may slip
- \* Work both in class and at home usually complete and presented to the best of their ability but sometimes suffers from lack of preparation
- \* Well equipped for every lesson and usually punctual
- \* Deadlines generally met
- \* Evidence of consolidation of ideas outside class
- \* Should never distract others

## D UNSATISFACTORY - This grade will be given if any of the following apply.

- \* Tendency for attention in lessons to wander
- \* Work both in class and at home may suffer from lack of effort
- \* Pupil forgets to bring correct equipment to lessons and arrives late
- \* Work maybe handed in late or incomplete
- \* Evidence for revision for tests may be lacking
- \* Tendency to distract others

## E UNACCEPTABLE - This grade will be given if any of the following apply.

- \* Attention in lessons frequently wanders
- \* Work both in class and at home is poor
- \* Pupil rarely arrives with the correct equipment
- \* Work is frequently handed in late or incomplete
- \* Pupil often distracts others

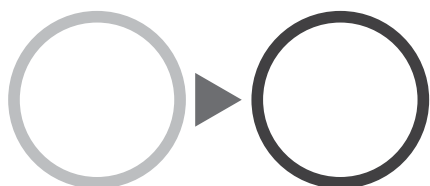

Assessment Date:  
To hit my target I will:

---

---

---

---

\_\_\_\_\_ achieved

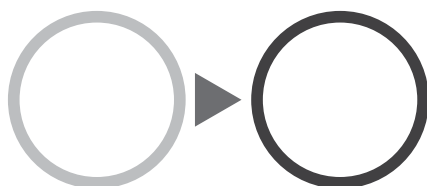

Assessment Date:  
To hit my target I will:

---

---

---

---

\_\_\_\_\_ achieved



Assessment Date:  
To hit my target I will:

---

---

---

---

\_\_\_\_\_ achieved

SAMPLE



### SPAG

Remember to double check your work.

Accuracy

Spelling

Grammar

Date / /



### KEY WORDS

---

---

---

---



### KEY POINT

I have learnt

---

---

---

---

SAMPLE



---

---

---

---



---

---

---

---

# General Health & Safety Rules

When you are in any workshop or design space, there are general H&S rules you will need to follow. It is important that you know and remember these, to keep yourself and others safe. In the space below, what are the 10 rules?

- 1.
- 2.
- 3.
- 4.
- 5.
- 6.
- 7.
- 8.
- 9.
- 10.

Name the tool/equipment, label its parts, describe how to use it, and state any specifics that relate to its safe use.

Name the tool/equipment, label its parts, describe how to use it, and state any specifics that relate to its safe use.

Name the tool/equipment, label its parts, describe how to use it, and state any specifics that relate to its safe use.

Name the tool/equipment, label its parts, describe how to use it, and state any specifics that relate to its safe use.

Name the tool/equipment, label its parts, describe how to use it, and state any specifics that relate to its safe use.

Name the tool/equipment, label its parts, describe how to use it, and state any specifics that relate to its safe use.

Name the tool/equipment, label its parts, describe how to use it, and state any specifics that relate to its safe use.

Name the tool/equipment, label its parts, describe how to use it, and state any specifics that relate to its safe use.

Name the tool/equipment, label its parts, describe how to use it, and state any specifics that relate to its safe use.

**APPROVED!**

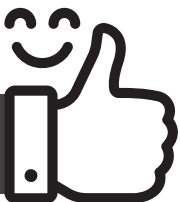

This work has met the expectations of the BHS DTE Department for H&S.

Teacher signature:

Date of completion:

Name the tool/equipment, label its parts, describe how to use it, and state any specifics that relate to its safe use.



AMPERE



**doodle**

Order more books at  
[www.doodle.ac](http://www.doodle.ac), by email  
[books@doodle.ac](mailto:books@doodle.ac) or give  
us a call on 0191 401 8410.

Doodle's exercise book 2.0 project has been printed using an alcohol-free process with a water-based varnish and vegetable-based printing inks, which are non-hazardous and are from renewable sources. The materials on our exercise books leave zero carbon footprint on our wonderful planet.

Every time you buy a box of doodle's exercise book 2.0, not only are the carbon impacts of the materials balanced, you also contribute to the continual protection of vital forest areas around the world!

Learn more about how you're helping to save the planet at [www.doodle.ac](http://www.doodle.ac)