

# FLYCAM Redking Handheld Camera Stabilizer (FLCM-RK)

## Assembly Manual



### What's In The Box

Please inspect the contents of your shipped package to ensure you have received everything that is listed below.



Stabilizer Central Post



Base Weight Platform



16 Weights Plates

All rights reserved.

No part of this document may be reproduced, stored in a retrieval system, or transmitted by any form or by any means, electronic, mechanical, photo-copying, recording, or otherwise, except as may be expressly permitted by the applicable copyright statutes or in writing by the Publisher.



Camera Plate Platform



Base Camera Platform



Dovetail Quick Release Plate



4 x Screws For Weight Platform



Allen key with Extra knobs Screws



4 x Weight Closers & Rubber Washer



Bag Packing

## FEATURES

### Dovetail Quick Release Plate

Manfrotto 501 compatible  
Quick Camera Mounting/Dismounting

### Camera balance plate

Tilt-able to maintain dynamic balance

### laser Engraved Guide Scale Markings

Quick & Precise adjustments

### Precision Three Axis Gimbal

Collet lock system  
3-Axis rotation control

### Foam Cushioned Handle

Comfortable handheld operation

### No-Tools Telescopic Central Post

adjusts camera's vertical balance

### Counter Weight

Expandable Base  
Holds counterweights to maintain balance



# FUNCTIONS

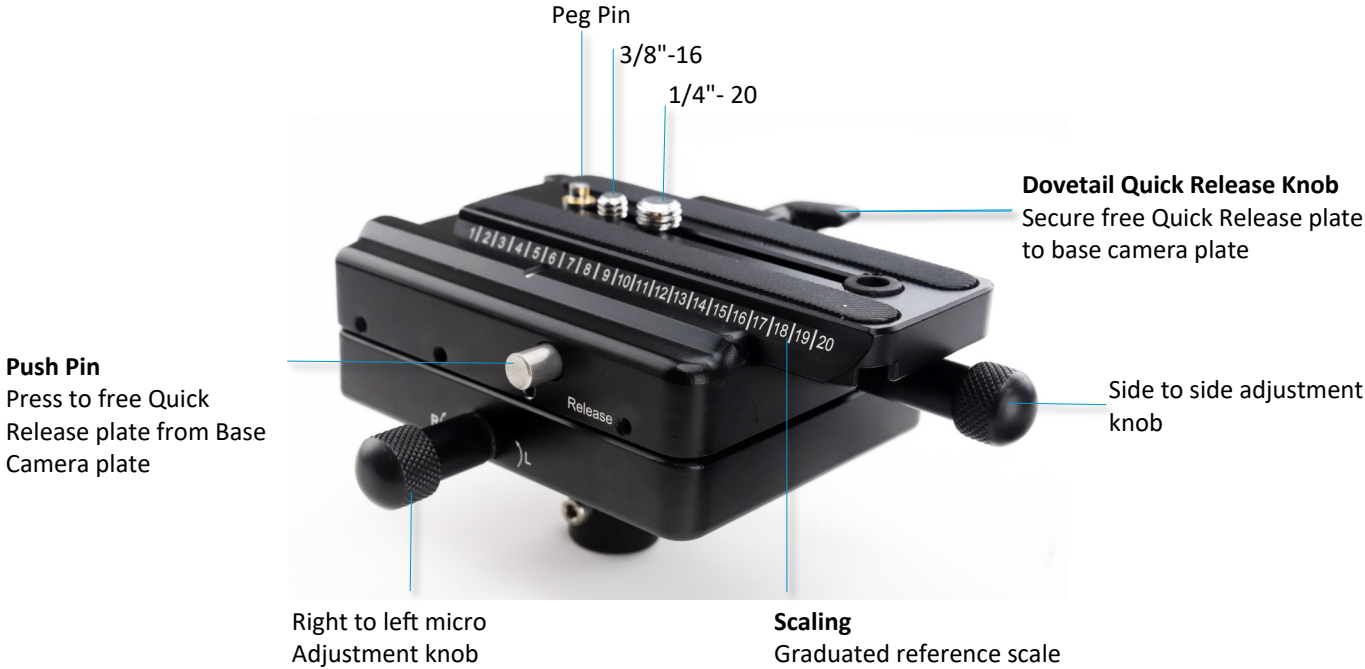

## Redking Handheld Camera Stabilizer Setup

- Remove the cap from the middle of the base platform, and you will see 1/4 thread located in the center, as shown in the image.



- Loosen the locking knob present on the central post such that Telescoping Post extends outwards. Attach the extended part of the post via threaded insert at the bottom to the 1/4 screw present on the expandable base platform.



- Two knobs are present on the extendable base platform to extend the stabilizer's counterweight base plate. Remove 1st bolt from both sides, extend out the base plate and lock it with the same bolt.

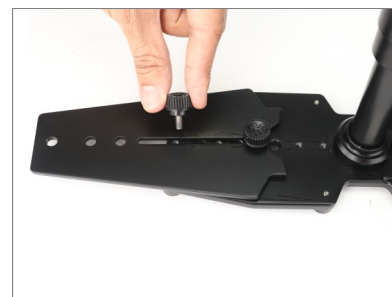

- From the bottom, insert all four Screws into the four slots located on either end of the Expandable Base Platform.

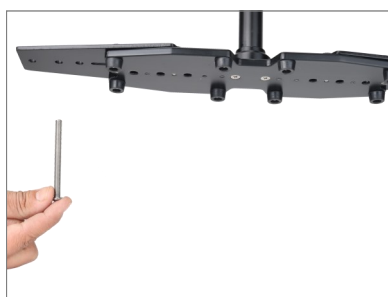

- Insert the Counterweight plates and slide them down on the screws until they are resting on the base platform. Secure the counterweight plates with the weight closer to prevent weight movement.

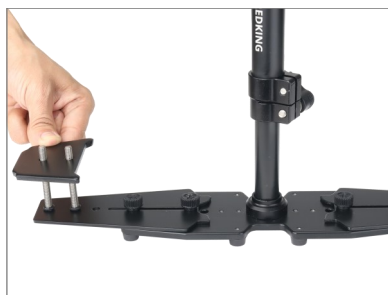

**NOTE:** The number of Counterweights will vary depending on your camera weight. Don't worry about this too much; later, you will set the number of Counterweights to the correct amount required for your specific camera.

- Remove bolts from both sides of the head platform. Mount the head plate to the central post and re-insert the bolts to tighten correctly.



- Now, remove the Dovetail Quick Release Plate from the Camera Mounting Platform. First, push in the side pin and hold it in. Your Dovetail Quick Release Plate should now be able to slide back out of the Camera Mounting Platform.



- Place and center align the Dovetail Quick Release plate on the backside of your camera. Make sure that the Dovetail Quick Release is in alignment, square with your camera bottom.

**NOTE:** If you have a camera/camcorder larger than the one shown in the manual, you must find the actual front to back center of gravity of your camera.



- Securely mount the camera on the dovetail plate. Then, slide in the dovetail plate to the camera base platform and tighten it with the side knob.



- The Camera Mounting Platform comes with a beveled edge. Line up the beveled edge with your camera's center of gravity mark found in Release the Dovetail Safety Pin when finished.



## Micro Balancing of Camera Head Plate Setup

- Loosen the side knob present on your dovetail plate for side to side (horizontal) positioning.



- Similarly, the camera mounting platform offers front-to-back movement adjustment with the help of knobs.



## Adding Weight & Positioning for Proper Balance

- Continuing the assembly and balance requirements to make your Flycam Redking Video Stabilizer fully functional you will note that the base platform has a provision to mount the balance weights via 2x BH bolts secured with knobs on both sides of the post



The purpose of the counter weight system is to match the low end of the stabilizer to the weight of the camera and accessories at the high/top end with the gimbaled handle as the pivot point in between.

The heavier the camera and accessories, the more weights are required to achieve proper balance. Generally as you add weight to one side of the central post, an equal amount has to be added to the other side to maintain horizontal balance.

However if you are using an offset configuration such as a flip out viewfinder or off center accessories, extra weights might be needed on the opposite side of the post to counter act and maintain proper balance.

Total weight fixed to the base platform should be equal to the weight of your camera plus the head and any accessories.

## Balancing your Stabilizer

- Before you begin the balancing process, check the following and make sure they have been done:

1. Camera is securely attached to the DOVETAIL QUICK RELEASE PLATE and the DOVETAIL QUICK RELEASE LOCK is tight.
2. The Lens Cap has been removed.
3. Camera Battery and Recording Media are installed.
4. Flip out LCD into it's operating position.
5. Telescoping clamp has been tightened and weights have been added.



## Horizontal Balancing

Fine tune side-to-side or fore/after balance with the knobs on camera platform. Hold the sled absolutely vertical as you adjust. Turn the adjustment knobs with your other hand until you feel no pressure on your operating hand and the sled will be in static balance.

- Now that your Flycam Redking Camera Stabilizer is setup and assembled properly, you can test and setup the horizontal balance of the system. If the Stabilizer is horizontally balanced correctly, then camera will remain level and central post will remain vertical during operation, unless you intentionally position stabilizer otherwise or release any pan, tilt or roll pressure on central post.



When testing for correct horizontal balance you need to make sure that you pick up your Stabilizer from a flat surface (for e.g. a table) and that you let the Stabilizer hang freely as you hold it.

**NOTE:** If you do not have enough counter weight on the base platform at this time, the entire Stabilizer will flip completely upside down. If this happens add more counter weight below until during this test the Stabilizer remains up.

- If Stabilizer tilts to the front, then you need to move dovetail quick release plate towards back by using adjustment knobs. If Stabilizer tilts to the back, then move dovetail quick release plate towards front by using adjustment knobs. Always secure dovetail quick release plate after any adjustments. If you cannot get the front to back axis balanced with this method, then try re-mounting your camera to a different position on dovetail quick release plate.





## Vertical Balancing

Dynamic balance is extremely important for precise operation. For each arrangement of camera, monitor position, post length, accessories, etc. there are many possibilities for statically balancing the Stabilizer. However, for each arrangement, there is only one combination that also balances the sled dynamically.

Dynamic balance can easily be achieved by trial and error method. In all cases, when a sled is in dynamic balance, the camera's center of gravity will be towards rear of the center line of central post. This rule gives you some point to begin balancing the Stabilizer.

Now that your Stabilizer is horizontally balanced, its vertical axis can be tested and properly balanced. If the Stabilizer is vertically balanced correctly, then camera will remain level and central post will remain vertical during operation, unless you intentionally position stabilizer otherwise. If it is not balanced properly, then it will swing like pendulum when you walk, run, or turn.

**Slightly bottom heavy, it will be both stable and easier to control. Check the vertical balance by using this drop time test.**

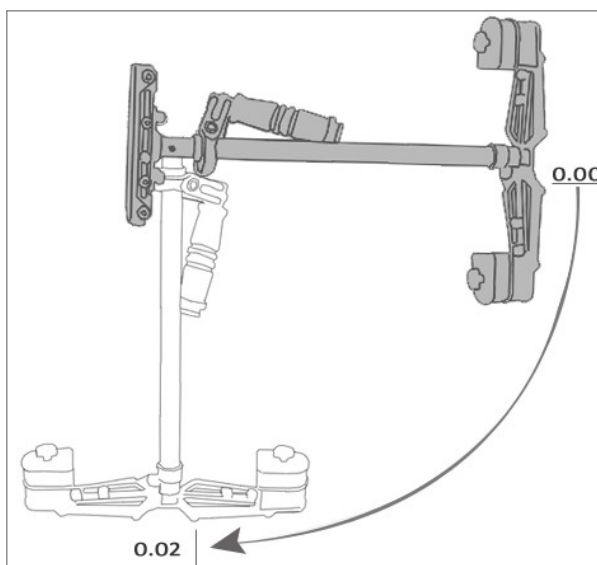

- Make sure that everything is tight.
- Grasp center post near the base and move it from vertical to horizontal.
- Hold it there. Be sure that it will not hit the stand when you drop it. Keep your free hand to catch the center post when it drops.
- Count how many seconds it take to fall to vertical. Try using a stopwatch.
- If the drop time is less then 2 seconds, it is too bottom heavy. You need to move the bottom mass closer to the post.
- If the drop time is more than two seconds, it is top heavy.

**A DROP TIME OF 2 - 2.5 SECONDS IS PREFERRED.**

**NOTE:** Recheck the balance by looking at the sled. If necessary, use side screws and bottom plate screws to make required adjustments.

## Holding your Flycam Stabilizer

When handling your Redking Video Camera Stabilizer one hand holds onto the handle while the other is used to gently guide the camera in the direction you wish to shoot and frame the shot. For normal shooting, hold the handle in the middle.

- For shots that require framing the camera up, down or sideways, hold the handle firmly at the bottom.



**NOTE:** Make sure that your "GUIDING HAND" and "HOLDING HAND" do not touch either the bearing assembly or the "YOKE" during shooting. For unconventional shots, like ones that require aiming the camera either straight up or down, or sideways, hold onto the Stabilizer on the lower part of the post, or down near the weight. This will allow your "GUIDING HAND" to have a greater degree of control over the Stabilizer while shooting erratic shots.

## Low-Mode Operation

- When operating Redking Stabilizer in Low-Mode, you will not be able to put your eye right up to the eyecup on viewfinder. For doing so will cause the unit to be restricted in its ability to stabilize and eliminate camera shake. You can either use camera's built-in LCD Monitor or attach an external LCD Monitor (**Not Included**) directly to the base platform of stabilizer. A 1/4"-20 monitor mounting hole is located at both the front and back edges of Base Platform.



**NOTE:** You can also attach an external LCD Monitor (**Not Included**) to the accessory shoe on top of your Camcorder. We believe that better results are obtained when you attach monitor to Flycam Redking Stabilizer's base, because this way you have to look slightly down to see the monitor and so, your feet are more visible to your peripheral vision. This makes negotiating obstacles with the Stabilizer safer.



## Balancing Review

Proper system balance can only be achieved once your camera is set up with appropriate accessories ready for shooting. This means batteries, lenses, media cards, LCD viewfinder/monitor, quick release plate, on-cam lights, and all the gear you will use for your recording session.

- Remove top plate of FLYCAM and line up your camera so that its center of gravity is as close to the center of the plate as possible (basically hold the camera in your hand until it feels balanced both left and right as well as forward and back).
- Find hole in the plate that is as close to threaded tripod mount on your camera as possible (while you are still holding your camera's center of gravity to the center of the plate). Attach your camera (or quick release mount if you have one). Tighten it down so it won't accidentally rotate.
- Re-attach top plate to the FLYCAM . Center it, but don't worry about getting it absolutely perfect yet.
- Remove most of the weights from Base Platform, but leave one on each side.
- Insert the center post as far as it will go and tighten so it won't slide out.
- Hold the handle normally and turn the FLYCAM so that it is horizontal to the ground. Let go of the stalk while keeping a firm grip on the handle and count how long it takes to return to vertical again. You should be able to count a good, "One-one thousand, two-one thousand", before it rights itself. With only two little weights it might take considerably longer.
- Add one pair of weights at a time and repeat the "horizontal to vertical" test until it falls at the correct rate. It will probably not be perfect.
- You'll get one that's too slow and then you'll add a pair and it will fall too fast. When that happens, take off the last pair of weights that you added.
- Tighten down the weights so they don't slide around.
- To get count perfect, slightly lower the center post that attaches the Base Platform with the weights until you get the "one-one thousand, two one thousand" count to the vertical position.
- Fine-tune the left-right, forward-backward balance. You will have to go back and forth between the two directions to get the balance just right. Loosen the screw sets that allow the sled to move left and right. Adjust the top plate so that it is centered and tighten down the screws like you would a tire slowly and alternating side to side.
- Repeat for "forward-backward" balancing.
- Check to see if your camera is sitting level. If not, repeat the necessary steps until it does.
- Practice walking movements ensuring your body motion is not transmitted to your hands and then the FLYCAM and camera.

# Maintenance

## Bearing Maintenance

The main Bearing on your Flycam Handheld Stabilizer is attached to the Central Post about two inches from the top. It is of metal construction and partially enclosed by the Bearing assembly. If after a period of time your bearings don't turn smoothly, lubricate with a minimum of light machine oil. Light lubricating oil can also be used on the Yoke and Handle Bearings. Be sure to keep oil away from your camera, & clean up any over spill.

## Cleaning

Do not use solvents or harsh cleaners of any kind on your Flycam Hand held stabilizer. If the unit becomes dirty, use a damp soft cloth or sponge and a mild detergent to gently clean external parts.

## Storage

Should you need to store your Flycam Hand held stabilizer for a long period of time then place the unit upright in a dry or low to normal humidity area whenever possible. If you are unable to find this kind of environment then we suggest you store the unit in an airtight plastic container or bag. Standing the unit upright is preferred as it alleviates stress on the system.

**NOTE:** *Flycam Redking Video Camera Stabilizer doesn't work under water, nor is it waterproof. Avoid direct exposure to rain, water spray or any harsh environment. The bearings are not sand proof. Avoid getting dirt or sand in them.*

## Practice makes perfect - Walking the line

Practice this simple exercise to master your Flycam Redking stabilizer with professional results. Using masking or gaffers tape, create a cross mark on a flat and even wall. The mark becomes your framing center. On the floor leading up to the cross mark, lay a straight tape line of about 20 feet. Practice walking the line, while keeping the cross mark center framed and in focus. With a bit of effort, dramatic fluid like movements will become second nature and provide production value to all your set ups.

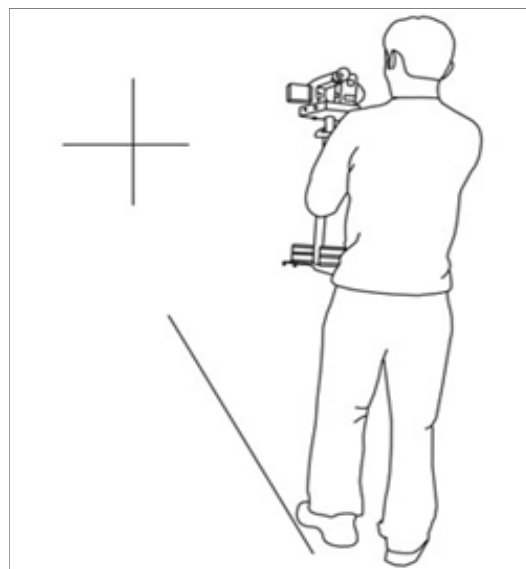

## YOUR FLYCAM REDKING HANDHELD CAMERA STABILIZER ALL DRESSED UP AND READY TO GO!



(SHOWN WITH OPTIONAL ACCESSORIES)

**Warranty:** We offer one year warranty for our products from date of purchase. Within this period of time, we will repair it without charge for labor or parts. Warranty doesn't cover transportation costs nor does it cover a product subjected to misuse or accidental damage. Warranty repairs are subjected to inspection and evaluation by us.

**Liability:** We are not liable for damage caused by products that we do not supply or from mishandling in transit, accident, misuse, neglect, lack of care of the product, or service by anyone other than our company.

**Contact Us:** In case of any kind of dissatisfaction, please Contact us immediately and we promise our utmost support and care until you use our product.