

SUNNY ISLAND 4.4M / 6.0H / 8.0H FOR ON-GRID AND OFF-GRID APPLICATIONS



SI4.4M-12 / SI6.0H-12 / SI8.0H-12



**WLAN communication is
now included**

Communicative

- Communication via Ethernet and WLAN
- Webconnect
- Optimized data logging

Reliable

- 10-year warranty
- Particularly high overload capability
- IP54 for reliable operation in extreme environments

Flexible

- Works with self-consumption systems, battery backup systems and off-grid systems
- Ideal for retrofits or modular expansions of single-phase and three-phase systems

- All lead-acid batteries and over 20 different lithium-ion batteries can be used

SUNNY ISLAND 4.4M / 6.0H / 8.0H

The most reliable all-purpose solution—easier than ever

The Sunny Island battery inverter supports a wide range of on- and off-grid installations with compelling product features—from operation in off-grid areas to home energy management. Users can benefit from SMA's experience in having installed more than 70,000 Sunny Island inverters installed worldwide. Thanks to its integrated web interface and standard interfaces WLAN and Ethernet, the Sunny Island 4.4M/6.0H/8.0H can be easily configured and monitored via smartphone or tablet. And being a core element in the SMA Flexible Storage System, the Sunny Island temporarily stores self-generated power thus making it possible to use solar power around-the-clock.

Its high protection class, wide temperature range and exceptional overload capacity always provide the kind of reliability needed for off-grid use. Intelligent load and energy management keeps the system running even in critical situations. The Sunny Island is the ultimate all-purpose solution—and includes a 10-year warranty.

Three-phase off-grid system

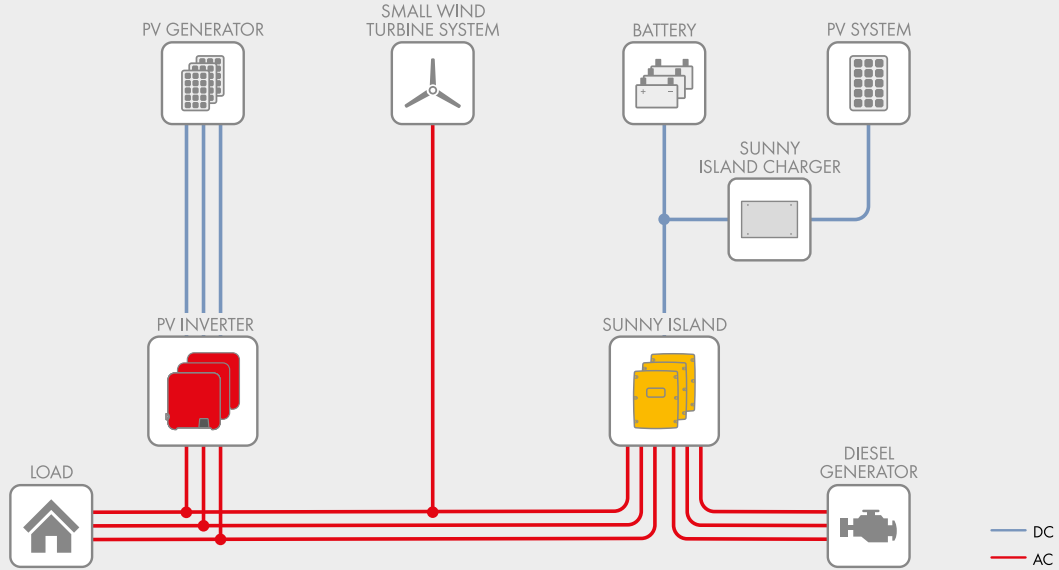

Single-phase on-grid system

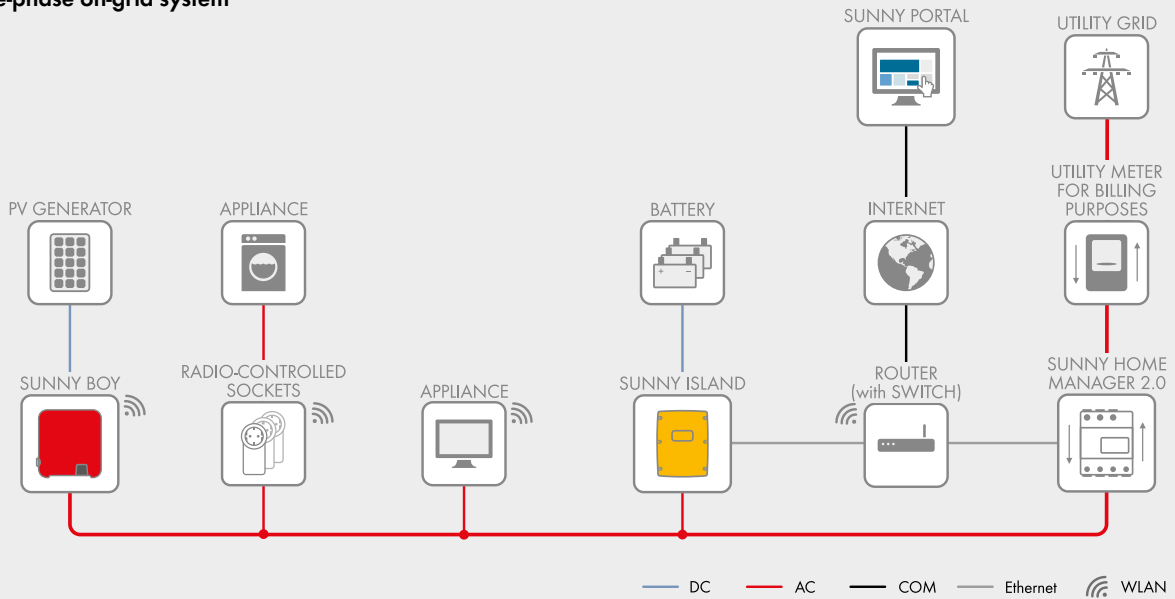

Efficiency curve

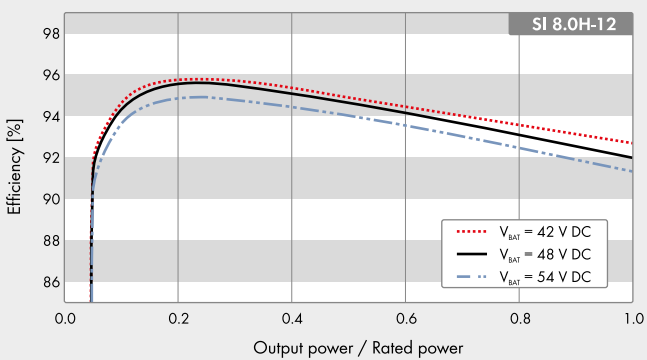

Power-temperature curve

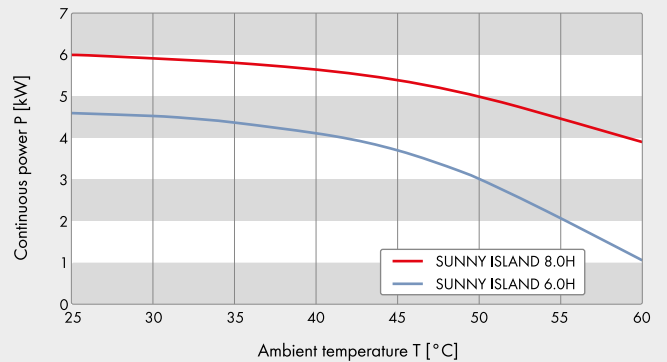

Technical Data	Sunny Island 4.4M ¹⁾	Sunny Island 6.0H	Sunny Island 8.0H
Operation on the utility grid or generator			
Rated grid voltage / AC voltage range	230 V / 172.5 V to 264.5 V		
Rated grid frequency / permitted frequency range	50 Hz / 40 Hz to 70 Hz		
Maximum AC current for increased self-consumption (grid operation)	14.5 A	20 A	26 A
Maximum AC power for increased self-consumption (grid operation)	3.3 kVA	4.6 kVA	6 kVA
Maximum AC input current	50 A	50 A	50 A
Maximum AC input power	11500 W	11500 W	11500 W
Stand-alone or emergency power operation			
Rated grid voltage / AC voltage range	230 V / 202 V to 253 V		
Rated frequency / frequency range (adjustable)	50 Hz / 45 Hz to 65 Hz		
Rated power (at U _{nom} , f _{nom} / 25 °C / cos φ = 1)	3300 W	4600 W	6000 W
AC power at 25 °C for 30 min / 5 min / 3 sec	4400 W / 4600 W / 5500 W	6000 W / 6800 W / 11000 W	8000 W / 9100 W / 11000 W
AC power at 45 °C continuously	3000 W	3700 W	5430 W
Rated current / maximum output current (peak)	14.5 A / 60 A	20 A / 120 A	26 A / 120 A
Total harmonic distortion output voltage / power factor at rated power	< 4% / -1 to +1	< 4% / -1 to +1	< 4% / -1 to +1
Battery DC input			
Rated input voltage / DC voltage range	48 V / 41 V to 63 V	48 V / 41 V to 63 V	48 V / 41 V to 63 V
Maximum battery charging current / rated DC charging current / DC discharging current	75 A / 63 A / 75 A	110 A / 90 A / 103 A	140 A / 115 A / 130 A
Battery type / battery capacity (range)	Li-Ion ²⁾ , FLA, VRLA / 100 Ah to 10000 Ah (lead-acid) 50 Ah to 10000 Ah (Li-Ion)		
Charge control	IUoU charge procedure with automatic full charge and equalization charge		
Efficiency / self-consumption of the device			
Maximum efficiency	95.5%	95.8%	95.8%
No-load consumption / standby	18 W / 6.8 W	25.8 W / 6.5 W	25.8 W / 6.5 W
Protective devices (equipment)			
AC short-circuit / AC overload	● / ●		
DC reverse polarity protection / DC fuse	- / -		
Overtemperature / battery deep discharge	● / ●		
Overvoltage category as per IEC 60664-1	III		
General Data			
Dimensions (W / H / D)	467 mm / 612 mm / 242 mm (18.4 inches / 21.1 inches / 9.5 inches)		
Weight	44 kg (97 lbs)	63 kg (138.9 lbs)	63 kg (138.9 lbs)
Operating temperature range	-25 °C to +60 °C (-13 °F to +14 °F)		
Protection class in accordance with IEC 62103	I		
Climatic category as per IEC 60721	3K6		
Degree of protection according to IEC 60529	IP54		
Features/function			
WLAN, Speedwire / Webconnect / SI-SYSCAN (Multicuster)	● / ● / -	● / ● / ○	● / ● / ○
Micro SD memory card for extended data logging	○		
Display via smartphone, tablet, laptop / multifunction relay	● / 2		
Three-phase systems (including rotating magnetic field) / battery-backup function	● / ●		
State of charge calculation / full charge / equalization charge	● / ● / ●		
Battery temperature sensor / data cables	○ / ●		
Certificates and approvals	www.SMA-Solar.com		
Cover color yellow / aluminum white	○ / ○		
Warranty 5/10 years	● / ● ⁴⁾		
For off-grid applications			
Automatic rotating magnetic field detection / generator support	● / ●		
Parallel connection / Multicuster	● / ●		
Integrated soft start	●		
Accessory			
For off-grid applications			
Battery fuse ³⁾	○		
Sunny Island Charger SIC50-MPT ³⁾ / SMA Cluster Controller	○ / ○		
For on-grid applications			
Sunny Home Manager / SMA Energy Meter / automatic transfer switch for battery backup ³⁾	○ / ○ / ○		
● Standard feature ○ Optional feature – Not available			
1) Cannot be used in Multicuster systems			
2) see "List of Approved Batteries" at www.SMA-Solar.com			
3) Procurement via external supplier			
4) When registering			
All specifications, last updated: April 2017			
Type designation	SI4.4M-12	SI6.0H-12	SI8.0H-12

SUNNY DESIGN

System Design Made Easy

