

The e-Bike Display

Users Manual

Contents

PRODUCT NAME AND MODEL	1
SPECIFICATIONS.....	1
APPEARANCE AND SIZE.....	1
FUNCTION.....	2
GENERAL OPERATION.....	3
◆ ON/OFF.....	3
◆ DISPLAY INTERFACE.....	3
◆ PEDAL ASSIST.....	4
◆ LIGHTING ON/OFF.....	4
◆ ASSIST LEVEL SELECTION.....	5
◆ BATTERY SOC INDICATION.....	5
◆ MOTOR OUTPUT.....	6
◆ USB CONNECTION.....	6
◆ ERROR CODE	6
DISPLAY SETTING.....	8
◆ UNIT.....	8
◆ SERVICE TIP.....	8
◆ BRIGHTNESS.....	9
◆ AUTO-OFF.....	9
◆ MAX LEVEL.....	10
◆ TRIP RESET.....	10
◆ AL SENSITIVITY.....	11
◆ PASSWORD.....	11
INFORMATION.....	12
◆ WHEEL SIZE INFO.....	12
◆ SPEED LIMIT INFO.....	12
◆ BATTERY INFO.....	13
◆ CONTROLLER INFO.....	13
◆ DISPLAY INFO.....	14
◆ TORQUE INFO.....	14
◆ ERROR CODE.....	15
QUALITY ASSURANCE & WARRANTY SCOPE.....	16
CONNECTION LAYOUT.....	16
CAUTIONS.....	16
ATTACHED LIST 1: ERROR CODE AND DEFINITION.....	17

Product model

Intelligent TFT display for eBike; model: KD986

Specifications

36V/48V Power Supply

Rated working current: 50mA

Maximum working current: 200mA

Off leakage current: $<1\mu\text{A}$

Operating temperature: $-20^{\circ}\text{C}\sim 60^{\circ}\text{C}$

Storage temperature: $-30^{\circ}\text{C}\sim 70^{\circ}\text{C}$

Appearance and Size

KD986 Display appearance and dimension drawing (unit: mm)

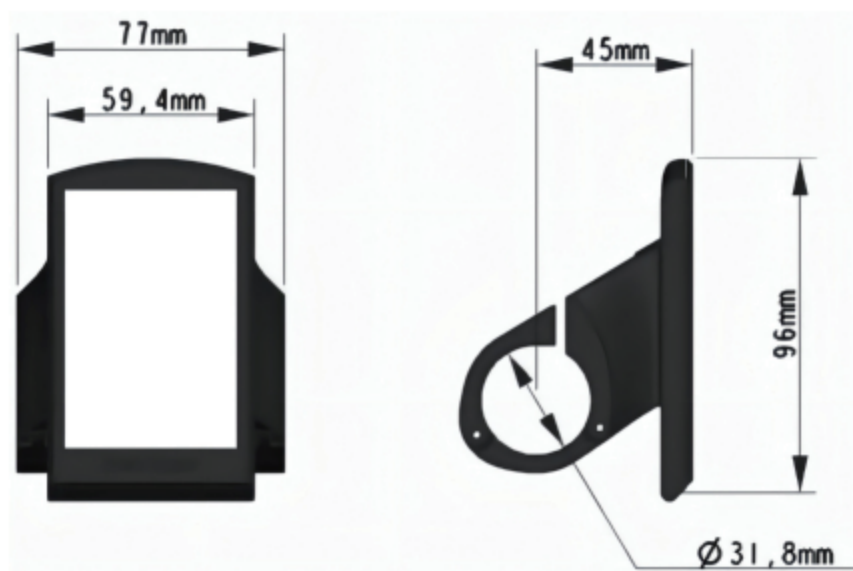

Remote appearance and dimension drawing (unit: mm)

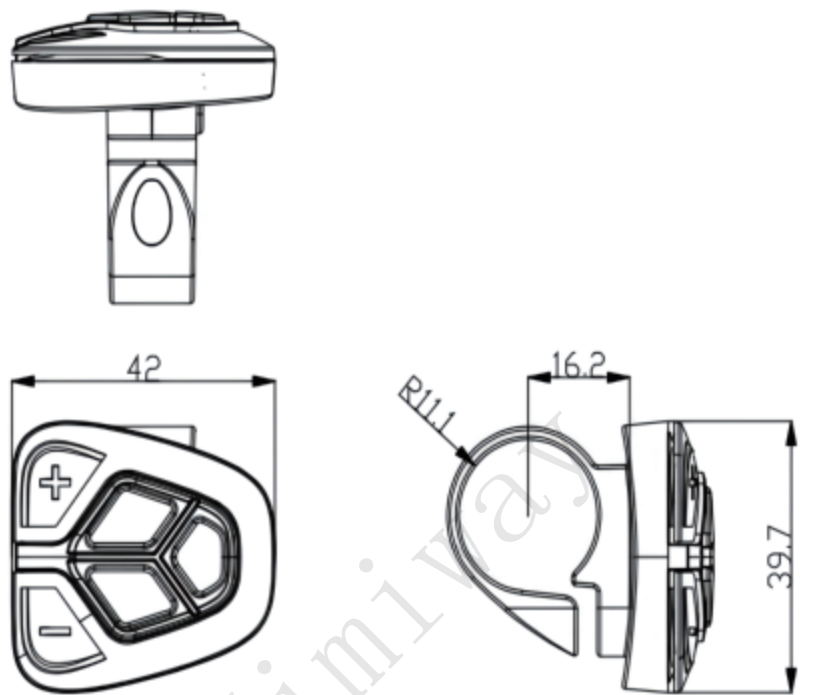

Function Summary

KD986 can provide a lot of functions to fit the user's needs. The indicating content are as follows:

- Battery SOC indication (5 bars)
- Motor power indication
- Assistance-level indication
- Speed indication (incl. running speed, max. speed, and avg. speed)
- Odometer and trip distance
- Pedal-assistance function
- Trip time indication
- Backlight on/off
- Error code indication
- USB connection indicator
- Various parameters settings (e.g., wheel size, speed-limited, battery level bar, assistance level, controller limited current, password enable, etc.)

General Operation

◆ Switching the eBike System On/Off

To switch on the eBike system, hold the "I" button for 2s.

Hold the "I" button for 2s again and the eBike system will be switched off and no longer use the battery power.

When switching off the eBike system, the leakage current is less than 1 μ A.

■ When parking the eBike for more than 5 minutes, the eBike system switches off automatically.

◆ Display Interface

After switching on the eBike system, the display will show speed and trip distance as default.

1. **Briefly** press the "I" button to switch between following the elements on *the lower right*.

ODO (Km) → Max. Speed (Km/h) → Avg. Speed (Km/h) → Time (Min.)



Display Indication Cycle Interface

◆ Switching Pedal-Assistance Mode On/Off

Briefly press the "-" button till the  icon is showing to enter the pedal-assistance level.

To activate the pedal-assistance function, keep holding the "WALK" button. After 2s, the eBike's drive is activated at a uniform speed of 6 Km/h. Pedal-assistance stops as soon as you release the "WALK" button. The eBike system stops the power output

immediately.

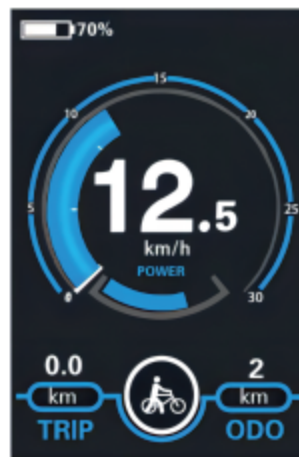



Pedal-assistance Mode

- The pedal-assistance function may only be used when pushing the eBike.

Be aware of the danger of injury when the wheels of the eBike do not have ground contact while using the pedal-assistance function.

◆ Switching the Lighting On/Off

To switch on the headlight, press and hold the  button for 2s. The display backlight brightness is automatically reduced.

Press and hold the  button for 2s again and the headlight can be switched off. The display automatically recovers backlight brightness.

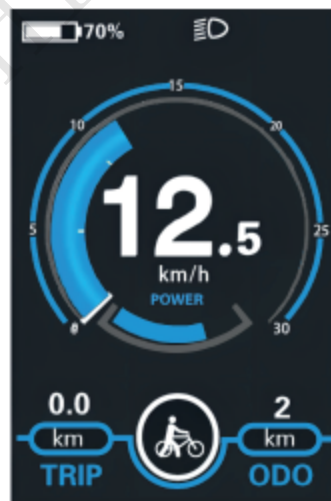

Switching the Lighting Mode On/Off Interface

◆ Assist Level Selection

Briefly press "+" or "-" button to switch between assist levels in order to change the motor output power. The default assist level ranges from level 0 to level 5. The output power is zero on Level 0. Level 1 is the minimum power and level 5 is the maximum power. When you reach 5, if you press the "+" button again the interface will still show 5 and

blinks to indicate the power is at its highest. At level 0, press the "-" button to reach pedal-assist level. Pressing the - button again still shows and blinks at the pedal-assist level.

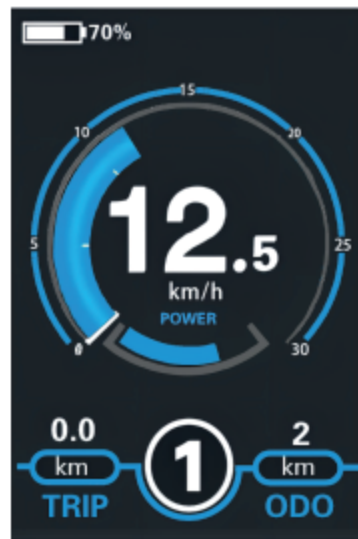

Assist Level Interface

◆Battery SOC Indicator

The five green bars represent battery SOC status. The five bars are bright when the battery is at high voltage. Each bar is equivalent to a capacity of approx. 20%.

When the battery is at low voltage, the battery frame will flash to indicate that the battery needs to be recharged immediately.



Battery SOC Indication Interface

◆Motor Power Indicator

The power of the motor can be read via the interface below:

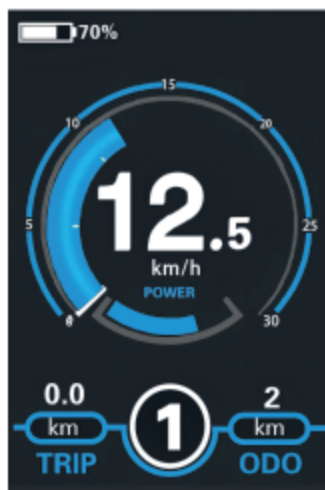

Motor Power Indication Interface

◆USB connection indication

When a USB external device is inserted into the display, the display interface will show as follows:

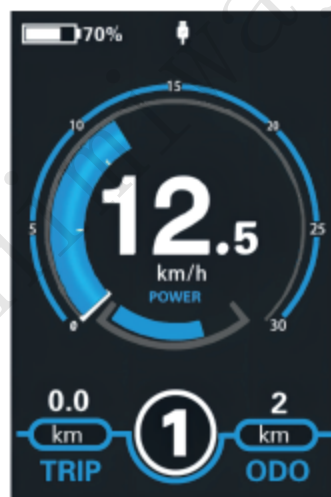

USB Connection Indication Interface

◆Error Code Indication

The components of the eBike system are continuously and automatically monitored. When an error is detected, the respective error code is indicated in the text indication area.

Error code info can be found in **Attached list 1**.

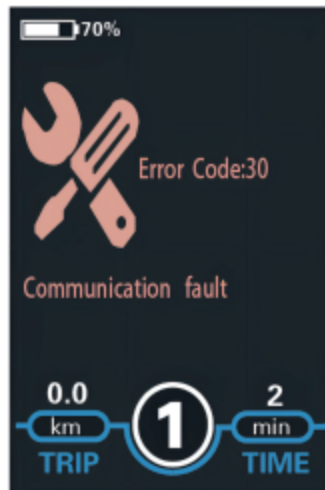

Error Code Indication

■ Have the display repaired when an error code appears. Otherwise, you will not be able to ride the bike normally. Please always refer to an authorized dealer.

Settings

Press the **i** button to turn on the display,

To access the settings menu, hold both the “+” button and the “-” button for 2s.

Display Settings and **Information** will be listed:

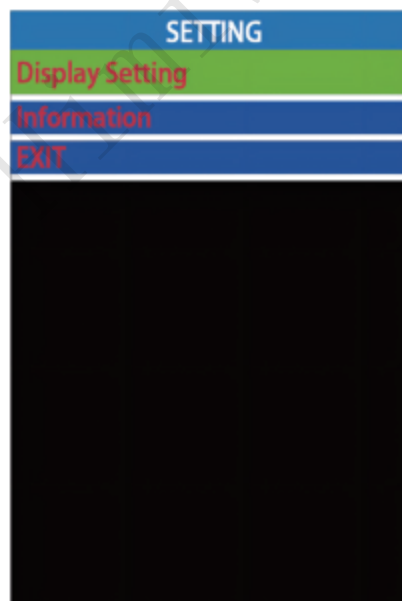

Settings Interface

■ All the settings are operational on a parked eBike.

Display Settings:

◆ **Unit**

Unit represents the unit toggling settings.

To toggle the unit, press the "+" button or the "-" button to choose the desired unit, then press the "i" button to confirm.

To store a changed setting, press the "i" button. The default value is metric (km).

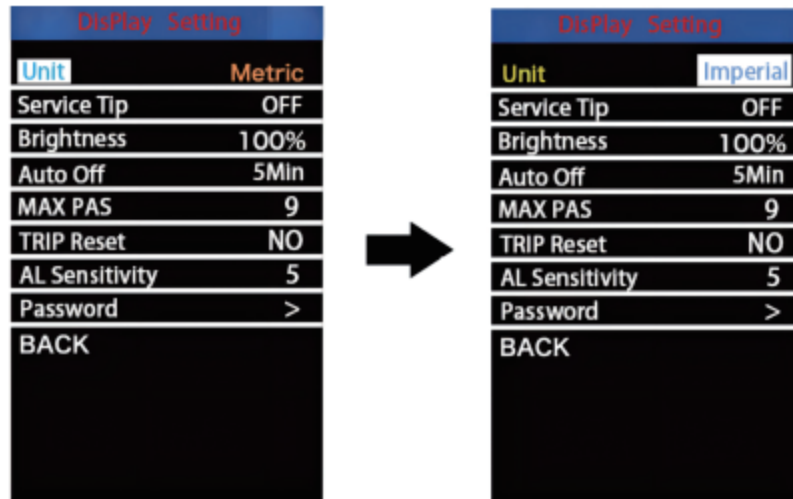

Unit Settings

◆ Service Tip

Service tip is the maintenance reminder for eBike users. When the running distance reaches over 5000 km, the word "**SERVICE**" will appear and blink on the screen.

To change the basic settings, press the "+" or the "-" button to choose ON or OFF.

ON- maintenance reminder is enabled. OFF- maintenance reminder is disabled.

To store a changed setting, press the "i" button. The default value is ON.



Service Tip Settings Interface

◆ Brightness

Brightness represents LCD backlight brightness settings. The default is 100%.

To change the backlight brightness, press the "+" button or the "-" button to choose

the desired percentage.

To store a changed setting, press the "i" button.

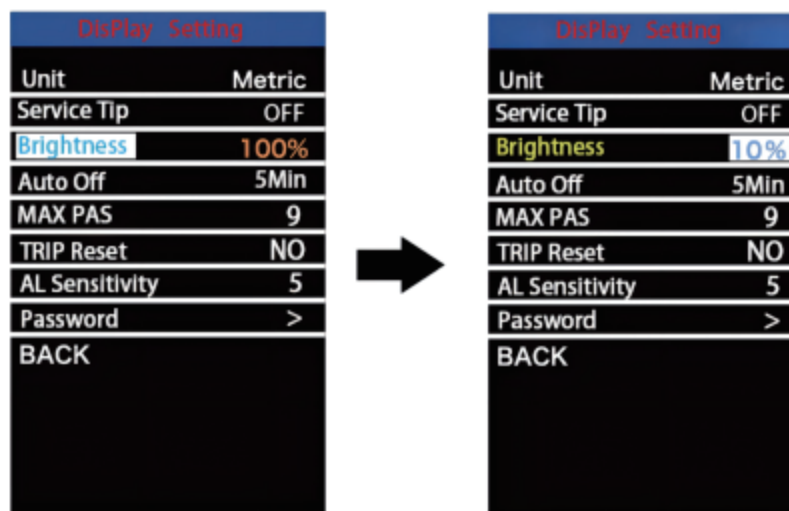

The diagram shows two side-by-side screenshots of the 'Display Setting' menu. The left screenshot shows 'Brightness' set to '100%'. The right screenshot shows 'Brightness' set to '10%'. A black arrow points from the left screenshot to the right screenshot, indicating the change.

Display Setting	
Unit	Metric
Service Tip	OFF
Brightness	100%
Auto Off	5Min
MAX PAS	9
TRIP Reset	NO
AL Sensitivity	5
Password	>
BACK	

Brightness Settings Interface

◆Auto-Off

Auto-off represents the display's automatic shutdown time settings.

To change the display's automatic shutdown time, press the "+" button or the "-" button to choose the desired duration. The default auto-off time is 5 minutes. The settable range is 1-9 minutes and OFF. **OFF** means the auto-off function is disabled.

To store a changed setting, briefly press the "i" button to confirm.

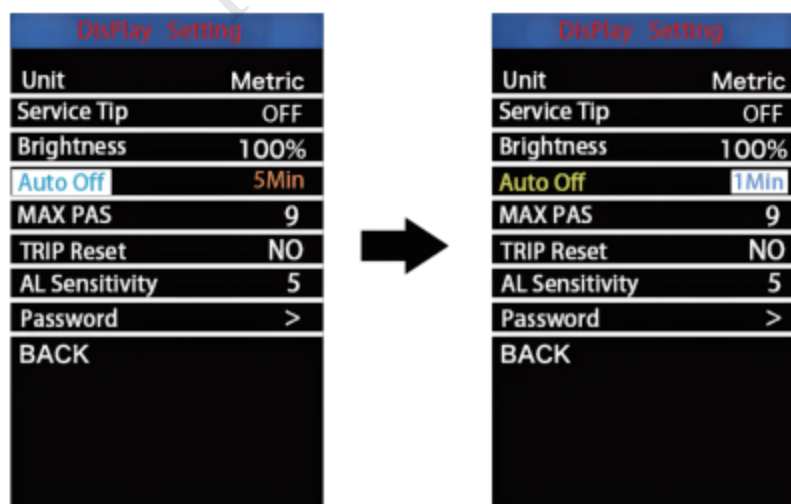

The diagram shows two side-by-side screenshots of the 'Display Setting' menu. The left screenshot shows 'Auto Off' set to '5Min'. The right screenshot shows 'Auto Off' set to '1Min'. A black arrow points from the left screenshot to the right screenshot, indicating the change.

Display Setting	
Unit	Metric
Service Tip	OFF
Brightness	100%
Auto Off	5Min
MAX PAS	9
TRIP Reset	NO
AL Sensitivity	5
Password	>
BACK	

Auto-Off Settings Interface

◆MAX Level

Max level represents the maximum assist level setting.

Press the "+" button or the "-" button to select the desired value. The settable values

are 3/5/9.

To store a changed setting, press the "i" button. The default value is .

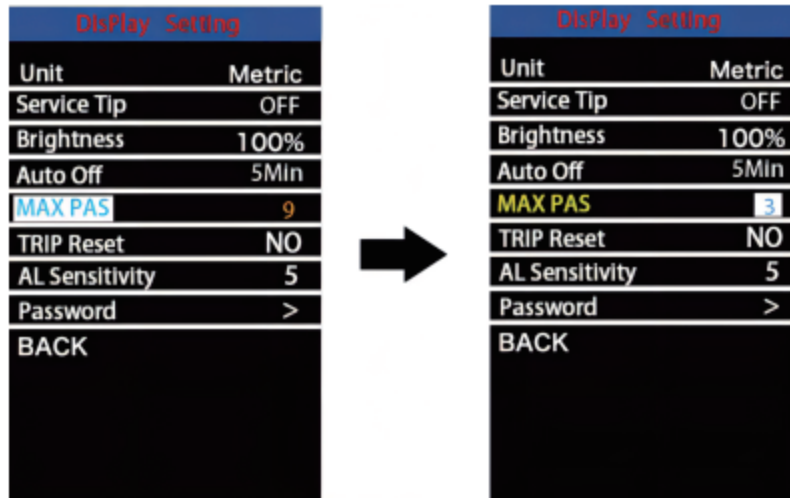

DisPlay Setting	
Unit	Metric
Service Tip	OFF
Brightness	100%
Auto Off	5Min
MAX PAS	9
TRIP Reset	NO
AL Sensitivity	5
Password	>
BACK	

DisPlay Setting	
Unit	Metric
Service Tip	OFF
Brightness	100%
Auto Off	5Min
MAX PAS	9
TRIP Reset	NO
AL Sensitivity	5
Password	>
BACK	

Max Level Settings

◆ Trip Reset

Trip reset represents the trip distance clearance setting.

To reset trip distance, press the "+" button or the "-" button to select Yes or No. Yes represents clearing a trip distance. No represents not clearing a trip distance.

To store a changed setting, press the "i" button. The default value is NO.

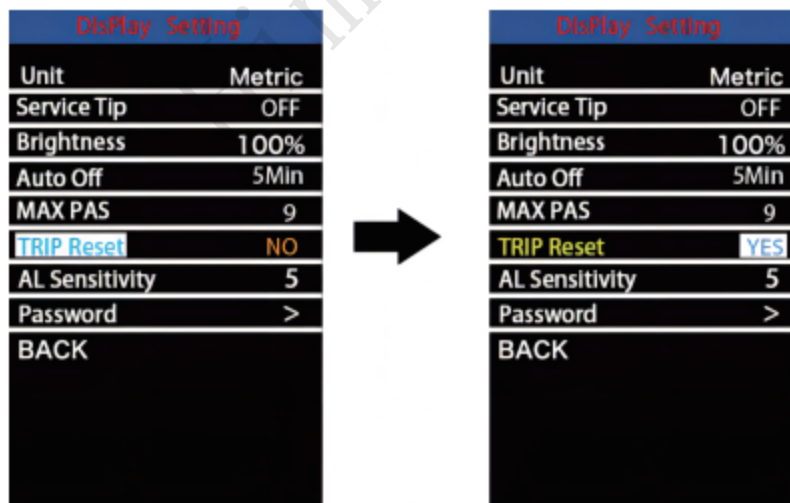

DisPlay Setting	
Unit	Metric
Service Tip	OFF
Brightness	100%
Auto Off	5Min
MAX PAS	9
TRIP Reset	NO
AL Sensitivity	5
Password	>
BACK	

DisPlay Setting	
Unit	Metric
Service Tip	OFF
Brightness	100%
Auto Off	5Min
MAX PAS	9
TRIP Reset	YES
AL Sensitivity	5
Password	>
BACK	

Trip Reset Interface

◆ AL Sensitivity

AL sensitivity represents ambient light sensor settings. It can help with automatically adjusting the screen brightness as per the ambient light conditions. When you ride the bike at night or in a place where there is a lack of light, the display

backlight and bike light will be turned on automatically.

The sensitivity of the AL sensor ranges from 1 to 5 and OFF (light sensor function is disabled). The default value is 3. Press +/- button to choose the desired sensitivity value.

To store a changed setting, briefly press the "i" button to confirm.

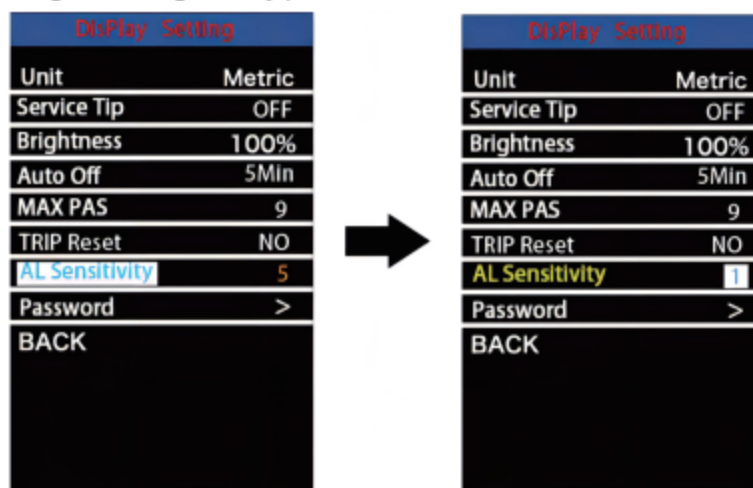

AL Sensitivity Settings

◆ Password

Password is the power-on password settings.

In the settings page, select "Password". Briefly press the i button to enter the password setting interface. Choose "Start Password" and press the i button to confirm. Press +/- to choose ON and press the i button to enable password function. Press +/- to choose the desired password numbers and press the i button to confirm. When the password is complete, enter the password again and password setting is done.

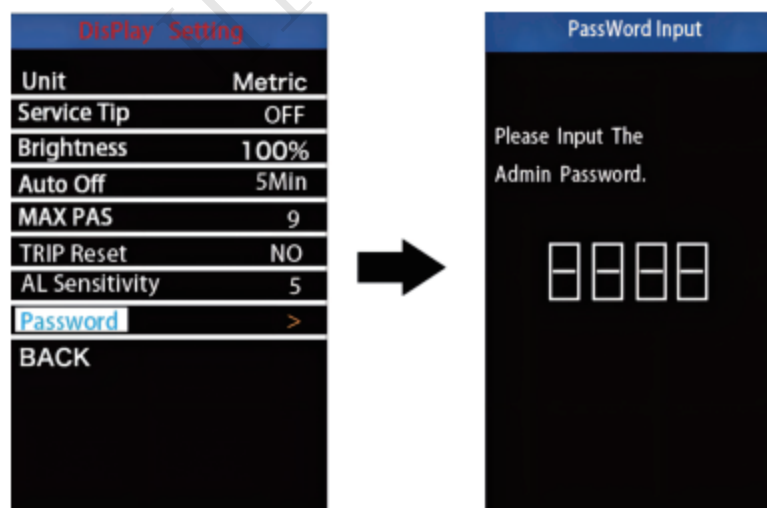

Password Settings Interface

* After display settings are done, press BACK to return to the settings interface.

Information:

◆ Wheel

Wheel contains the information on the wheel size. It is only for your information and is not settable.

Information	
Wheel	28Inch
Speed Limit	25.0Km/h
Batter Info.	>
Ctrl Info.	>
Display Info.	>
Torque Info.	>
Error Info.	>
BACK	

Wheel Size Information

◆ **Speed Limit**

Speed limit contains the information on the speed limit. It is only for your information and is not settable.

Information	
Wheel	28Inch
Speed Limit	25.0Km/h
Batter Info.	>
Ctrl Info.	>
Display Info.	>
Torque Info.	>
Error Info.	>
BACK	

Speed Limit Information

◆ **Battery Info**

In the information page, choose "Battery Info". Press the **i** button to check the battery information. Choose "**Back**" to exit the battery info page. Choose "**Next page**" to flick

through pages. The viewed information includes current temperature, maximum temperature, minimum temperature, total voltage, current, average current, battery SOC, full capacity, relative charging state, absolute charging state, cycle period, maximum non-charging time, recent non-charging time, battery core voltage, etc.

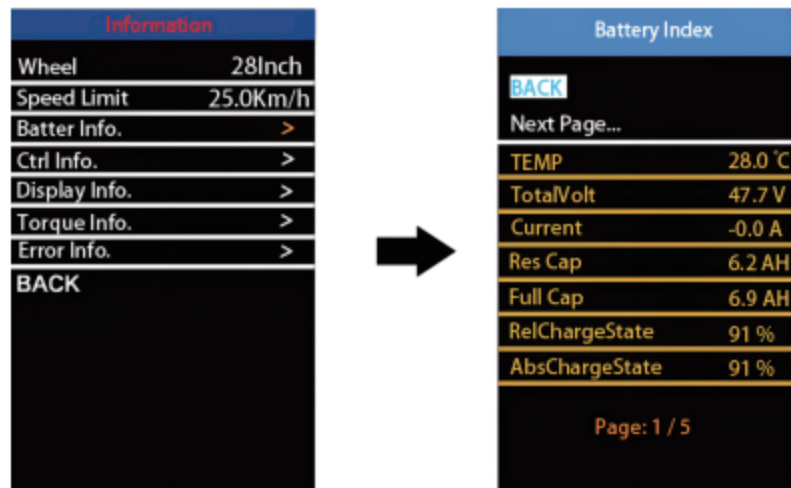

Battery Info Page

◆ Controller Info

In the information page, choose “**Ctrl Info**” and press the **i** button to check the controller software version and hardware version. Press the **i** button again to exit the controller information page.

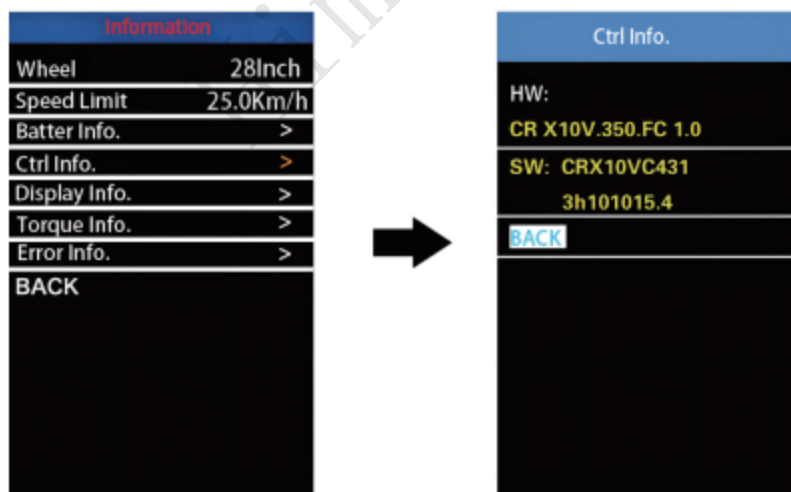

Controller Info Page

◆ Display Info

In the info page, choose “**Display Info**” and press the **i** button to check the display software version and hardware version. Press the **i** button again to exit the display info

page.

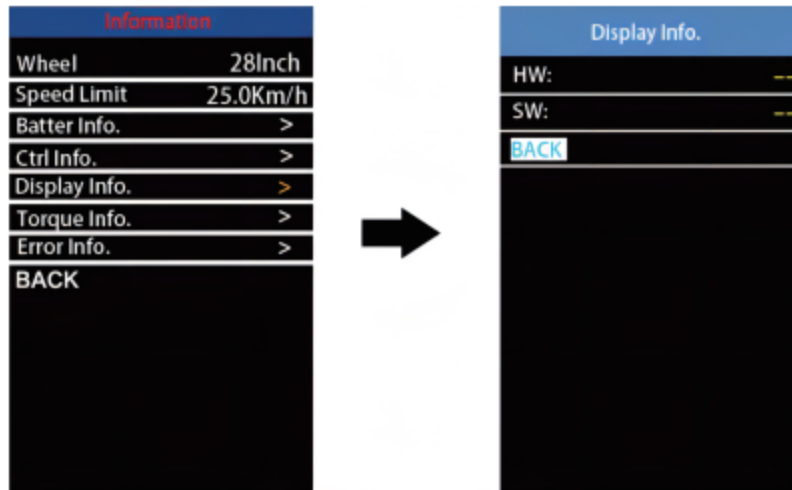

Display Info Page

◆Torque Info

In the info page, choose "**Torque Info**" and press the **i** button check the torque sensor software version and hardware version. Press the **i** button again to exit the torque info page.

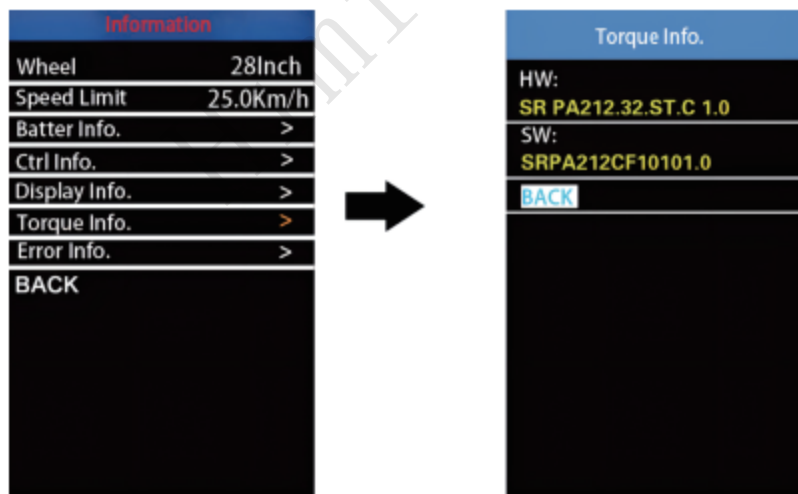

Torque Info Page

◆Error Code

In the info page, choose “**Error Code**” and press the **i** button to check the error code history. You can view up to 10 historical error codes. Press 3 buttons at the same time, “**+**”, “**WALK**”, and “**On/Off**”, to clear the error codes. Press the **i** button to exit the error code history page. Please see the code and definition in **Attached list 1**.



Warning Code Info Page

■ If there is not any operation within 20s, the display will exit the settings state.

Quality Assurance and Warranty Scope

I Warranty

- 1) The warranty will be valid only for products used in normal usage and conditions.
- 2) The warranty is valid for 24 months after the shipment or delivery to the customer.

II Others

The following items do not belong to our warranty scope.

- 1) The display is demolished.
- 2) The damage to the display is caused by incorrect installation or operation.
- 3) The shell of the display was broken when the display was out of the factory.
- 4) The wire of the display is broken.
- 5) The fault or damage of the display is caused by a force majeure (e.g., fire, earthquake, etc.).
- 6) Beyond the warranty period.

◆Connection Layout

Connector wire sequence



Display-side connector

Mating connector from controller side

Wire sequence table

Wire No.	Color	Function
1	Black	-
2	Orange	KEY BUTTON SIGNAL
3	Green	CAN-H
4	White	CAN-LOW
5	Brown	+

■ Some wires use a water-proof connector, users cannot see the inside color.

Operation Cautions

- Be cautious. Do not attempt to disconnect the connector when the battery is on.
- Try to avoid hitting the eBike.
- Do not modify system parameters to avoid parameter disorder.
- Make sure the display is repaired when an error code appears.

Attached list 1: Error code definition

Error code	Definition
04	Fault with the throttle
05	The throttle did not return
07	Over voltage fault
08	Fault with motor hall sensor inside
09	Fault with the motor phase wire
10	Motor temperature is too high
11	Fault with temperature sensor inside motor
12	Fault with current sensor inside controller
13	Fault with battery temperature inside
14	Controller temperature is too high
15	Fault with temperature sensor inside controller
21	Fault with speed detecting sensor
23	Fault with the headlight
25	Fault with torque signal of the torque sensor
26	Fault with speed signal of the torque sensor
27	Over current fault
30	Communication fault
31	Low voltage protection
32	High voltage protection
33	Fault with brake detecting sensor
35	Fault with 15V power detecting sensor
36	Fault with key detecting sensor
37	Fault with watchdog
61	Shifter is stuck
62	Shifter not reset
81	Fault with Bluetooth
41	Total voltage is too high
42	Total voltage is too low
43	Total current is over limit
44	Monomer voltage is too high
45	Battery temperature is too high
46	Battery temperature is too low
47	SOC is too high
48	SOC is too low
71	Fault with the electronic lock