

SKU #	Motor/Blade Finish
VS523P3-L12-SM2-1-FM	Brushed Nickel Antique Walnut Solid Wood Blades



LABELLE

3-Blade | 52" | Flushmount
DC MOTOR 120V
INTEGRATED LED LIGHT KIT



DC Motor

- 10-Speed | Reversible
- Motor | 148 X 15mm
- RPM: High 215 Low 65
- 4770 CFM | 26 W | Efficiency = 140

Blade

- 3-Blade | 52" Sweep
- Material: Solid Wood
- 14° Pitch

Light Kit

- LED Light Board
- 22W 2000 Lumens
- Dimmable From 10%-100% | 10 Levels Dimming
- Color Temperature :
2700K Warm Light | 3500K Neutral Light | 4000K Cool Light
- Lens: Glass

Control

- Remote Control (Standard)

Certification

- ETL Listed

Warranty

- Fan Motor: Three-Year Limited Warranty
- LED Light Kit: Five-Year Limited Warranty
- Fan Blade: One-Year Limited Warranty
- Other: Three-Year Limited Warranty

Measurements

- Dimensions(in.): 11 H (to lowest point) x 7 W(housing)
x 7.6 H (top of blade)
- Product Weight (lbs.): 12.4 N.W. | 15.4 G.W.
- Box (in.): 25.6 W X 12.4 D X 9.6 H

Shipping

- Container Loading:
20GP 571 pcs | 40GP 1171 pcs | 40HQ 1372 pcs

Dimensions

11"	7"	7.6"
Height (lowest point)	Width (housing)	Height (top of blade)

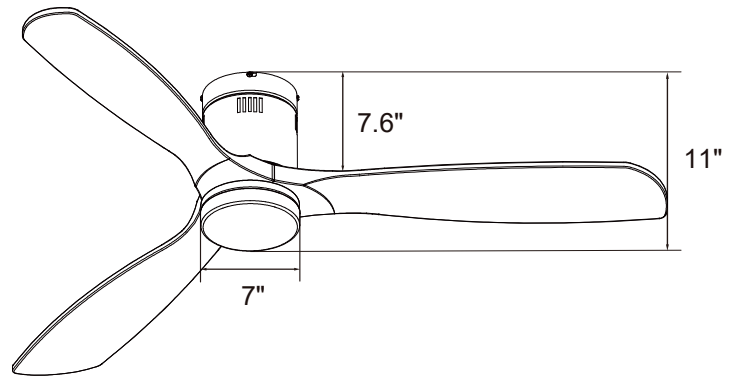

Fan Control Options

Simple and intuitive design with standard layout.

Multifunctional: fan speed control, fan forward/reverse direction, fan on/off, light brightness adjustment, warm/cool light switch, light on/off.

RF pairing, and Wi-Fi pairing.

Remote



- Remote (Standard)

Remote



- Remote (Optional)