

SKU #	Motor/Blade Finish
CFP523N4-N10-W1-1-FM	White   White ABS Blades



## HAVEN

3-Blade | 52" | Flushmount | Pull Chain  
DC MOTOR 120V  
NO LIGHT



Intertek

Fan Motor

Light Kit

Fan Blade

Other

### DC Motor

- 5-Speed | Reversible
- Motor | 148 X 15mm
- RPM: High 170 Low 50
- 4000 CFM | 17 W | Efficiency = 192

### Blade

- 3-Blade | 52" Sweep
- Material: ABS
- 11° Pitch

### Light Kit

- No Light
- Metal Plate

### Control

- Pull Chain (Standard)
- Wall Control (Optional)
- Remote (Optional)

### Certification

- ETL Listed

### Warranty

- Fan Motor: Three-Year Limited Warranty
- LED Light Kit: Five-Year Limited Warranty
- Fan Blade: One-Year Limited Warranty
- Other: Three-Year Limited Warranty

### Measurements

- Dimensions(in.): 11.4 H (to lowest point) x 6.8 W (housing) x 8.5 H (top of blade)
- Product Weight (lbs.): 9.6 N.W. | 12.4 G.W.
- Box (in.): 25.4 W X 10.9 D X 7.9 H

### Shipping

- Container Loading:  
20GP 820 pcs | 40GP 1680 pcs | 40HQ 1960 pcs

### Dimensions

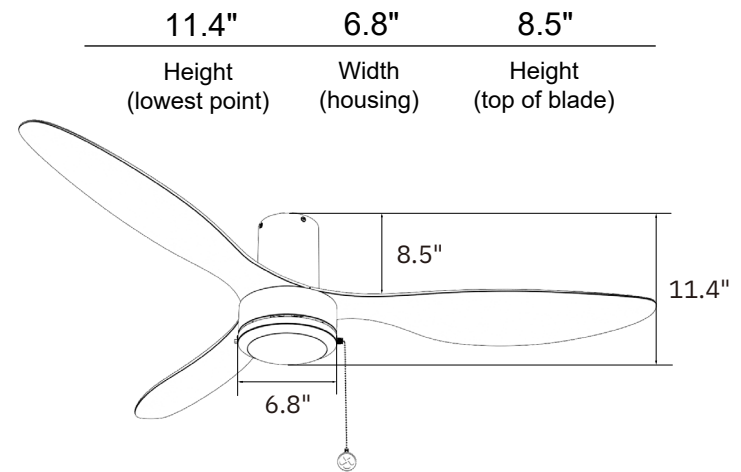

### Fan Control Options

Simple and intuitive design with standard layout.  
Multifunctional: fan speed control, fan forward/reverse direction, fan on/off, light brightness adjustment, warm/cool light switch, light on/off.

Push Button

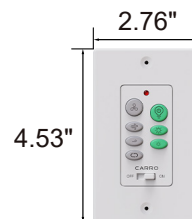

Knob



Remote



- Pull Chain (Standard)
- Hardwired Wall Control(Optional):  
Push Button or Knob  
(Single Live Wire, No Neutral Needed)
- Remote (Optional)