



SPSX

SPSX SERIES SINGLE POINT STAINLESS STEEL LOAD CELLS



Stainless steel load cells for off center loads, suitable for example to build CE-M approved scales with a single load cell with maximum dimensions of 600x800 mm.

---

CAPACITIES (kg): 100, 300, 500.

---

OIML R60. C3 precision class.

---

17-4 PH stainless steel. IP67 protection.

---

The best solution  
for advanced industrial  
applications

## MAIN FEATURES

- C3 PRECISION CLASS
- OFF CENTER LOAD COMPENSATED
- MADE IN 17-4 PH STAINLESS STEEL
- IP67 PROTECTION
- MAX. CAPACITIES FROM 100 TO 500 kg
- FOR PLATFORMS WITH DIMENSIONS UP TO 600 X 800 mm
- SHIELDED CONNECTION CABLE
- TEST CERTIFICATE AVAILABLE UPON REQUEST

## TECHNICAL FEATURES

- Minimum load cell verification interval:  $V_{min} = E_{Max} / 15.000$
- Maximum number of verification intervals:  $n_{LC} = 3000$
- Full Scale Output:  $2mV/V \pm 10\%$
- Temperature effect on zero:  $0,01\% FS/10K$
- Temperature effect on full scale output:  $0,001\% FS/10K$
- Compensated Temperature Range:  $-10^{\circ}C/+40^{\circ}C$
- Operating Temperature Range:  $-10^{\circ}C/+50^{\circ}C$
- Creep at nominal load in 30 minutes:  $\pm 0,01\% F.S.$
- Maximum tolerated excitation voltage: 15 VDC
- Input Resistance:  $390 \pm 15 \text{ Ohm}$
- Output Resistance:  $359 \pm 5 \text{ Ohm}$
- Insulation Resistance (100V)  $>1000 \text{ MOhm}$
- Safe Overload: 300% F.S.
- Ultimate Overload: 300% F.S.
- Nominal displacement:  $< 0.5 \text{ mm}$
- 6-wire shielded cable, 3m long, 5mm diameter

## ATEX Version

- The CCATEX certificate makes the load cell suitable for use in hazardous areas with protection methods according to:  
ATEX II 1G Ex ia IIC T6 (Ta  $-20 \div +40^{\circ}C$ ) TX (Ta  $-20 \div +65^{\circ}C$ ) Ga  
ATEX II 1D Ex ta IIIC TX $^{\circ}C$  (Ta  $-20 \div +40^{\circ}C$ ) TX $^{\circ}C$  (Ta  $-20 \div +65^{\circ}C$ ) Da IP65.  
The certificate includes the manual and the ATEX CE conformity declaration (available in EN, DE, FR, and IT).
- **IMPORTANT:** the certificate refers to the single load cell. For systems with more load cells, it is necessary to order one certificate for each load cell.

## DETAIL 1

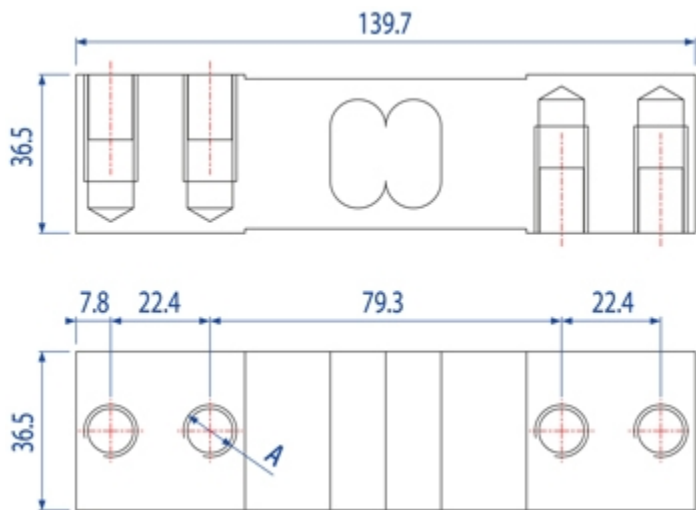



Code	Dimensions in mm
	A
SPSX300	M10
SPSX500	M12

Wiring Code	
<i>Colour</i>	<i>Function</i>
WHITE	OUTPUT +
GREEN	SENSE +
BLUE	INPUT +
RED	OUTPUT -
BLACK	INPUT -
GREY	SENSE -

## VERSIONS

### Versioni disponibili

Codice	Piatto Max (mm)	Max (kg)
SPSX100 	600 x 800	100
SPSX300 	600 x 800	300
SPSX500 	600 x 800	500



GRAVITATION LTD.

UNIT 2B SECTION 5 DUNSHAUGHLIN - - CO. MEATH - IRELAND

Tel. 00353469078900

Fax. 00353469078911

E-mail [info@gravitation.ie](mailto:info@gravitation.ie)

Web [www.gravitation.ie](http://www.gravitation.ie)

*All the specifications and images can be subject to variations and upgrades without prior notice.*