



RCA

"RCA" SERIES COLUMN LOAD CELLS



Analogue version of compression load cells, 4000 divisions, ideal for CE-M approved weighbridges, tanks, silos, etc. Manufactured in STAINLESS STEEL, with IP68 protection, fitted with "anti rat" armoured cable.

CAPACITIES (kg): 30000.

OIML R60. C4 precision class.

Stainless steel. IP68 protection.

The best solution
for advanced industrial
applications

MAIN FEATURES

- C4 PRECISION CLASS.
- MANUFACTURED IN STAINLESS STEEL.
- IP68 PROTECTION.
- 30.000 kg CAPACITY.
- "ANTI RAT" 20 m ARMOURED CABLE.
- TEST CERTIFICATE AVAILABLE UPON REQUEST.

TECHNICAL FEATURES

- Full Scale Output: 2mV/V +/- 0,1%
- Combined error of Full Scale Output: $\pm 0,017\%$
- Operating temperature range: -20°C/+60°C
- Input resistance: 815 \pm 20 Ohm
- Output resistance: 700 \pm 5 Ohm
- Safe overload: 150% F.S.
- 4-pole armoured cable.

ATEX Version

- The CCATEX certificate makes the load cell suitable for use in hazardous areas with protection methods according to:
ATEX II 1G Ex ia IIC T6 (Ta -20÷+40°C) TX (Ta -20÷+65°C) Ga
ATEX II 1D Ex ta IIIC TX°C (Ta -20÷+40°C) TX°C (Ta -20÷+65°C) Da IP65.
The certificate includes the manual and the ATEX CE conformity declaration (available in EN, DE, FR, and IT).
- IMPORTANT: the certificate refers to the single load cell. For systems with more load cells, it is necessary to order one certificate for each load cell.

<u>Wiring Code</u>	
<u>Colour</u>	<u>Function</u>
WHITE	OUTPUT +
RED	INPUT +
YELLOW	OUTPUT -
BLUE	INPUT -

DETAIL 1

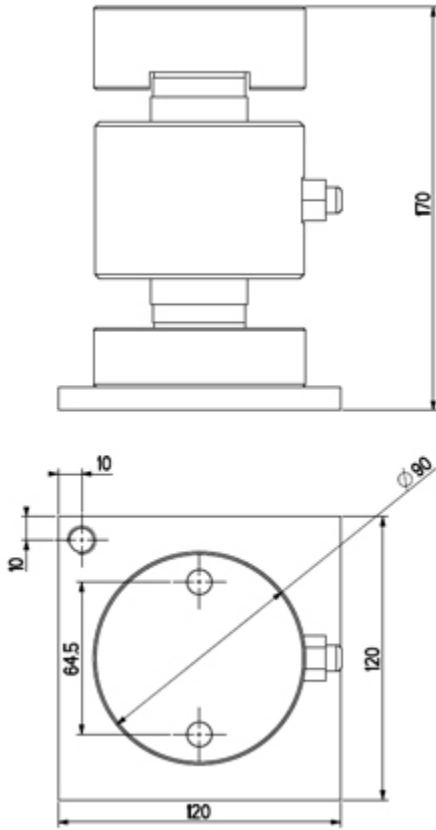

Technical drawing in mm, with KRCA kit.

VERSIONS

Versioni disponibili

Codice	Max (kg)
RCA30C4	30000



GRAVITATION LTD.

UNIT 2B SECTION 5 DUNSHAUGHLIN - - CO. MEATH - IRELAND

Tel. 00353469078900

Fax. 00353469078911

E-mail info@gravitation.ie

Web www.gravitation.ie

All the specifications and images can be subject to variations and upgrades without prior notice.