

## The E-Series Weighbridge

• Quality • Durability • Accuracy • Value



- Made in Ireland by the Weighbridge Experts
- Economically Priced for a Competitive Market
- Easy to Transport & Install
- Rugged Concrete Construction for Durability
- All Stainless Steel High Accuracy Load Cells
- Lightning Protection Built in as Standard
- Low-Profile 3 Module design makes relocation easy
- Available in 3m x 15m or 3m x 18m Sizes
- Custom Sizes Available on request
- Suitable for Pit or Over-ground Installation



**NSAI**

Legal Metrology Service

**AUTHORISED VERIFIER**

Gravitation Ltd. is an ISO 9001:2008 registered Company

Gravitation Ltd. Is an Authorised Verifier on Behalf  
of the Legal Metrology Service



## Easily Transported – No Cranes Necessary



3 Weighbridge Modules are easily transported on a Short Rigid Truck.

Modules can be off-loaded using Hi-Ab on Truck. No need for costly crane-hire!



## Flexible, Quick & Easy Installation

The E-Series can be set up on:

- An Existing Roadway
- A Newly Prepared Concrete Base
- 4 reinforced concrete pads
- 4 raised Concrete Plinths

Gravitation's Service Engineers can deliver the E-Series and have it ready for concrete in half a day!

This flexibility offers more options to the customer and big savings on time and money.



## Only One Concrete Pour Required

The Design of the E-Series with its rolled steel base means that it can be set up for concrete at its finished height, rather than casting on the ground.

Therefore, the deck concrete and ramps or pit surround can be poured at the same time.



## Suitable for Pit or Over-ground



The E-Series is available in Versions for both Pit and Over-Ground Installations



## Maintenance / Safety / Cleaning



Load Cell access for Inspection and Maintenance is facilitated by Cover Plates in the Weighbridge Deck. Side access is not required if Space is at a Premium (on Over-Ground Installations), and Man-holes are Not required for Pit Weighbridges.

Safer Access to the Weighbridge for Drivers can be ensured by Guide Pillars Built into the Ramps



The Common Problem of Dirt Building up at the ends of Weighbridge has been overcome with the design of the E-Series, lifting the Full-Width End-Plates makes Cleaning Easy.



## Additional Benefits

- The Low Profile Design of the E-Series (As Low as 300mm from ground level) minimises the length of ramps required and makes it a neater and less Obtrusive Weighbridge than Most on the Market
- Each of the 3 Weighbridge Modules Weighs ~ 8.5 Tonnes When full of Concrete, and therefore can be Lifted by a Hi-Ab on a Truck if the Weighbridge is to be Re-located at a later date.
  - A Unique Quality in a Concrete Weighbridge Design
  - At a Significantly Lower Price than a Steel Weighbridge.
- Cabling is routed through Steel Piping within the Deck Structure to Protect from Environmental / Rodent Damage.
- The Stainless Steel Rocker-Column Load Cells with Gas Discharge Tubes will Offer Many Years Trouble-Free Weighing.
  - Longitudinal and Lateral Stops are Built in to the Weighbridge Ramps
    - No need for Cumbersome Restraining Rods to be fitted.
- All Electronics on the E-Series are fully OIML Approved for Trade across Europe.

## Load Cells

### Stainless Steel Load Cell

#### Features:

- Up to C6 Accuracy
- Fully Welded Stainless Steel Body
- Ultimate IP69K Environmental Protection
- 35000 kg Capacity
- Built-in Lightning Protection
- Fitted with Articulated Top & Bottom Mounts with superior anti-rotation protection
- Supplied with 15m shielded signal cable as standard – custom sizes available
- Available with Rodent-Proof Cabling

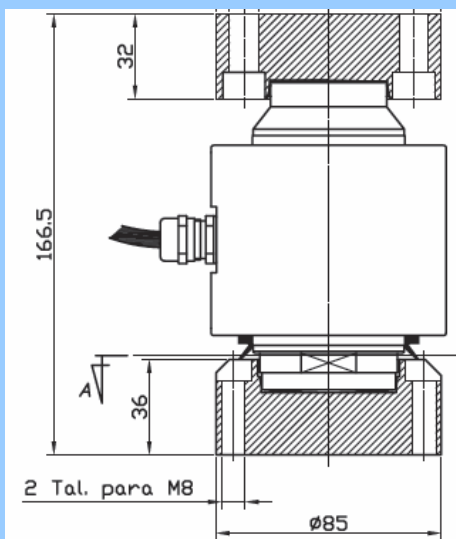

## Digital Weight Indicators



#### “ET” Series Touch Screen Indicator

- Advanced weight indicator
- Accurate & Reliable
- User friendly Interface
- Customisable Screen Layout
- Easily integrated with PC Software

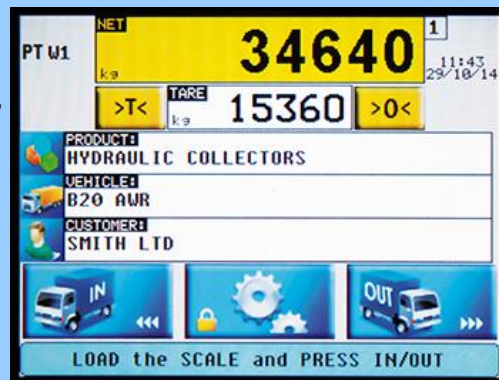

## Further Weighbridge Options

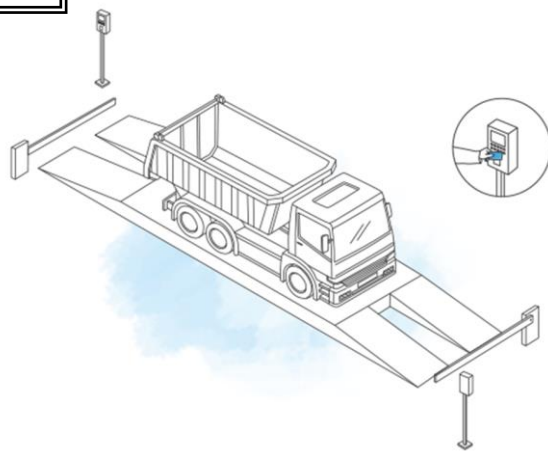

Gravitation Ltd. can tailor to your every weighing need.

- Computer Systems including Touch Screen Interfaces, Complete Un-Manned Systems including Driver Terminals, Traffic Lights, Barriers, Swipe Cards, CCTV and Remote Monitoring Software are just some of the options available.
- Contact us for Advice and Quotation

Gravitation Ltd.  
 Ph: +353 (0)46 907 8900 Fax: +353 (0)46 907 8911  
 E-mail: [info@gravitation.ie](mailto:info@gravitation.ie)  
 Website: [www.gravitation.ie](http://www.gravitation.ie)