



SWP820S



***Auto Darkening  
Welding Helmet***



## Professional Quality Welding Helmet

### SAFETY WARNINGS - READ BEFORE USING



#### WARNING

Read & Understand All Instructions Before Using



Auto-Darkening welding helmets are designed to protect the eye and face from sparks, spatter and harmful radiation under normal welding conditions. Auto-Darkening filter automatically changes from a light state to a dark state when an arc is struck, and it returns to the light state when welding stops.

**The Auto-Darkening welding helmet comes assembled. But before it can be used, it must be adjusted to fit the user properly. Check battery surfaces and contacts and clean it if necessary. Verify if the battery is in good condition and installed properly. Set up for delay time, sensitivity and shade number for your application.**

**The helmet should be stored in dry, cool and dark area and remove the battery, when not using it for a long time.**



#### WARNING



- This Auto-Darkening welding helmet is not suitable for laser welding and oxyacetylene welding / cutting processes.
- Never place this helmet and Auto-Darkening filter on a hot surface.
- Never open or tamper with the Auto-Darkening filter.
- This Auto-Darkening welding helmet will not protect against severe impact hazards.
- This helmet will not protect against explosive devices or corrosive liquids.
- Don't make any modifications to either the filter or helmet, unless specified in this manual.
- Don't use replacement parts any other than those specified in this manual. Unauthorized modifications and replacement parts will void the warranty and expose the operator to the risk of personal injury.
- Should this helmet not darken upon striking an arc, stop welding immediately and contact your supervisor or your dealer.
- Don't immerse the filter in water.
- Don't use any solvents on the filter screen or helmet components.
- Use only at temperatures:  $-10\text{ }^{\circ}\text{C} \sim +55\text{ }^{\circ}\text{C}$  ( $14\text{ }^{\circ}\text{F} \sim 131\text{ }^{\circ}\text{F}$ )
- Storing temperature:  $-20\text{ }^{\circ}\text{C} \sim +70\text{ }^{\circ}\text{C}$  ( $-4\text{ }^{\circ}\text{F} \sim 158\text{ }^{\circ}\text{F}$ ). The helmet should be stored in dry, cool and dark area and remove the battery, when not using it for a long time.
- Protect filter from contacting with liquid and dirt.
- Clean the filter surface regularly; don't use strong cleaning solutions. Always keep the sensors and solar cells clean using a clean lint-free tissue.
- Regularly replace the cracked / scratched / pitted front cover lens.
- Do not use this product without the correct protective clear lenses installed properly on both sides of the Auto-Darkening Filter cartridge.
- The materials which may come into contact with the wearers skin, can cause allergic reactions in some circumstances.



#### WARNING

Severe personal injury could occur if the user fails to follow the above mentioned warnings and/or fails to follow the operating instructions.



## COMMON PROBLEMS AND REMEDIES

### • Irregular Darkening Dimming

Headband has been set unevenly and there is an uneven distance from the eyes to the filter lens (Reset the headband to reduce the difference to the filter).

### • Auto-Darkening filter does not darken or flickers

- ① Front cover lens is soiled or damaged (Change the cover lens).
- ② Sensors are soiled (Clean the sensors surface).
- ③ Welding current is too low (Adjust the sensitivity level to higher).
- ④ Check battery and verify they are in good condition and installed properly. Also, check battery surfaces and contacts and clean if necessary. Please referring to the “POWER” on page 4.

### • Slow response

Operating temperature is too low (Do not use at temperatures below -10 °C or 14 °F).

### • Poor vision

- ① Front / inside cover lens and / or the filter is soiled (Change lens).
- ② There is insufficient ambient light.
- ③ Shade number is incorrectly set (Reset the shade number).
- ④ Check if removing the film on the front cover lens.

### • Welding helmet slips

Headband is not properly adjusted (Readjust the headband).



#### WARNING



The user must stop using the auto-darkening welding helmet immediately if the above-mentioned problems cannot be corrected. Contact the dealer.

## INSTRUCTIONS FOR USE

WARNING! Before using the helmet for welding, ensure that you have read and understood the safety instructions.

### • ADJUSTING THE FIT OF THE HELMET

The overall circumference of the headband can be made larger or smaller by rotating the knob on the back of the headband (See adjustment “Y” in fig.1). This can be done while wearing the helmet and allows just the right tension to be set to keep the helmet firmly on the head without it being too tight.

• If the headband is riding too high or too low on your head, adjust the strap which passes over the top of your head. To do this, release the end of the band by pushing the locking pin out of the hole in the band. Slide the two portions of the band to a greater or lesser width as required and push the locking pin through the nearest hole (See adjustment “W” in fig.1).

• Test the fit of the headband by lifting up and closing down the helmet a few times while wearing it. If the headband moves while tilting, re-adjust it until it is stable.

### • ADJUSTING THE DISTANCE BETWEEN THE HELMET AND THE FACE

Step 1: Undo the block nut (See “T” in fig.1) to adjust the distance between the helmet and your face in the down position.

Step 2: Re-tighten the block nut when adjustment is complete.

## • ADJUSTING VIEW ANGLE POSITION

Please see fig.2

## • SELECTING SHADE LEVEL

Select the shade level you require according to the welding process you will use by referring to the "Shade Guide Table" below for settings. The shade can be adjusted from shade 5 to 8 and 9 to 13 based upon welding process or application. Shade is adjusted by setting the shade range switch to the proper range (See fig.4), then turn the shade control knob on the lens of the helmet to the shade number required (See fig.5).

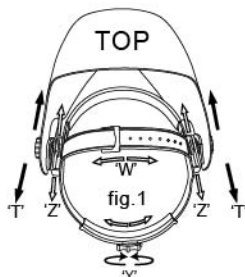

## • TEST

Press and hold "TEST" to preview shade selection before welding (See fig.3). When released then viewing window will automatically return to the light state (3.5 Shade). Press "TEST", if viewing window does not turn to dark state, replace batteries and try again.).

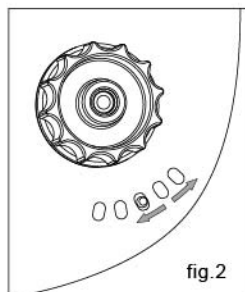

## • SENSITIVITY

The sensitivity can be set to "HIGH" or "LOW" by using the infinitely dial knob on the back of the shade cartridge. The "Mid-High" setting is the normal setting for everyday use. The maximum sensitivity level is appropriate for low welding current work, TIG or special applications. Where the operation of the helmet is disturbed by excess ambient light, or another welding machine close by, use the "LOW" setting (See fig.5). As a simple rule, for optimum performance, it is recommended to set sensitivity to the maximum at the beginning and then gradually reduce it, until the filter reacts only to the welding light flash and without annoying, spurious triggering due to ambient light conditions (direct sun, intensive artificial light, neighbouring welder's arcs, etc.)

## • SELECTING DELAY TIME

When welding ceases, the viewing window automatically changes from dark back to light but with a pre-set delay to compensate for any bright afterglow on the workpiece. The delay time/response can be set to "SHORT" (0.1 sec.) or "LONG" (1.0 sec.). As you require using the infinitely dial knob on the back of the shade cartridge (See fig.5). It is recommended to use a shorter delay with spot welding applications and a long delay with applications using higher currents. Longer delays can also be used for lower current TIG welding, and TIG / MIG / MAG pulse.

## • SELECTING THE GRIND OPTION

When the sensitivity knob is turned to the "Grind" position, the shade function is turned off



fig.3



fig.4

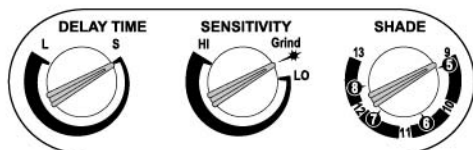
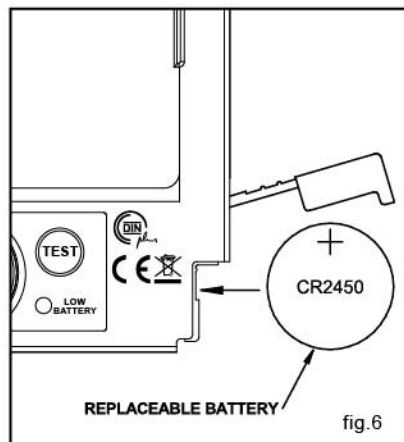

fig.5

allowing a clear view to grind a weld with the helmet providing face protection. Before restarting welding work, Ensure that the shade function is turned back on before welding again (See fig.5).

#### • POWER

When the low battery LED located on the lens starts to come to red, it is a warning for the battery to be replaced (See fig.6). The battery is located at the bottom corner of the ADF cartridge. Open the battery cover, replace the battery when Low battery light turn red. Be sure Positive (+) side of battery faces up(See fig.6).



## MAINTENANCE

- **REPLACING FRONT COVER LENS.** Replacing the front cover lens if it is damaged (cracked, scratched, soiled or pitted) (See fig.7).
- **REPLACING THE INSIDE COVER LENS.** If it is damaged (cracked,scratched, soiled or pitted).
- **CHANGING THE SHADE CARTRIDGE** (See fig.8).
- **FITTING NEW CARTRIDGE** (See fig.9).
- **CLEANING.** Clean helmet by wiping with a soft cloth. Clean cartridge surfaces regularly. Do not use strong cleaning solutions. Clean sensors and solar cells with methylated spirit and a clean cloth and wipe dry with a lint-free cloth.

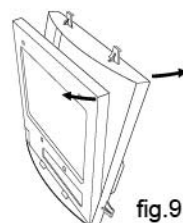
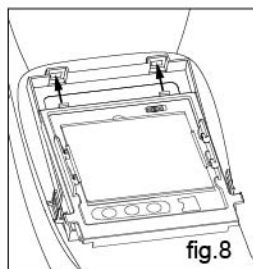
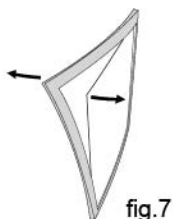

## TECHNICAL SPECIFICATIONS

Optical Class:	1 / 1 / 1 / 2
Viewing Area:	95x85mm (3.74"x3.35")
Cartridge Size:	133x114x9mm (5.25"x4.50"x0.35")
Arc Sensor:	4
Light State:	DIN 3.5
Shade:	Adjustable DIN 5 ~ 8 / 9 ~ 13
Shade Control:	Internal, Variable Shade
Power On/Off:	Fully Automatic
Sensitivity Control:	Low — High, by infinitely dial knob
UV/IR Protection:	Up to Shade DIN16 at all times
Power Supply:	Solar cell. Battery replaceable 1 X CR2450 lithium battery
Reaction Time:	1/25,000 s. from Light to Dark
Delay (Dark to Light):	0.1 ~ 1.0s by infinitely dial knob
Low Amperage TIG Rated:	≥ 2 amps (DC); ≥ 2 amps (AC)
Grinding:	Yes
Operating Temp.:	-10°C ~ +55°C (14°F ~ 131°F)
Storing Temp.:	-20°C ~ +70°C (-4°F ~ 158°F)
Helmet Material:	High Impact Resistance Nylon
Total Weight:	490g
Application Range:	Stick Welding (SMAW); TIG DC&AC; TIG Pulse DC; TIG Pulse AC; MIG/MAG/CO2; MIG/MAG Pulse; Plasma Arc Cutting (PAC); Plasma Arc Welding (PAW); Air Carbon Arc Cutting (CAC-A); Oxyfuel Gas Welding(OFW); Oxygen Cutting(OC); Grinding
Approved:	DIN <i>plus</i> , CE, ANSI Z87.1, CSA Z94.3, AS/NZS 1338.1

## PARTS LIST & ASSEMBLY

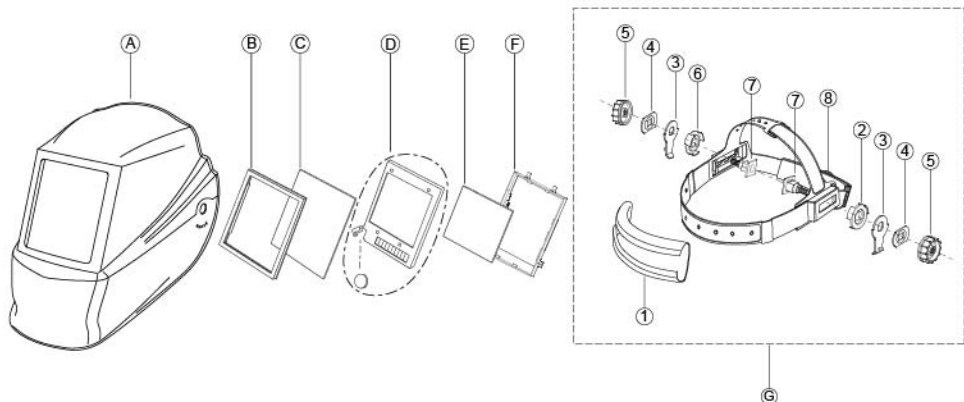

### Part List

ITEM	DESCRIPTION	QTY
A	Shell (Welding mask)	1
B	Rubber Holder	1
C	Front Cover Lens	1
D	Auto-Darkening Filter	1
E	Inside Cover Lens	1
F	Lens Holder	1
G*	Headgear Assembly (Including Sweatband)	1

### Part List of G\*

ITEM	DESCRIPTION	QTY
1	Sweatband	1
2	Left Limitation Washer	1
3	Angle Adjustable Washer	2
4	Washer	2
5	Block Nut	2
6	Right Limitation Washer	1
7	Screw	2
8	Adjustable Headband	1

## SHADE GUIDE TABLE

### GUIDE FOR SHADE NUMBERS

OPERATION	ELECTRODE SIZE 1/32 in. (mm)	ARC CURRENT (A)	MINIMUM PROTECTIVE SHADE	SUGGESTED <sup>(1)</sup> SHADE NO. (COMFORT)
Shielded metal arc welding	Less than 3 (2.5)	Less than 60	7	—
	3-5 (2.5-4)	60-160	8	10
	5-8 (4-6.4)	160-250	10	12
	More than 8 (6.4)	250-550	11	14
Gas metal arc welding and flux cored arc welding		Less than 60	7	—
		60-160	10	11
		160-250	10	12
		250-500	10	14
Gas tungsten arc welding		Less than 50	8	10
		50-150	8	12
		150-500	10	14
Air carbon Arc cutting	(Light)	Less than 500	10	12
	(Heavy)	500-1000	11	14
Plasma arc welding		Less than 20	6	6 to 8
		20-100	8	10
		100-400	10	12
		400-800	11	14
Plasma arc cutting	(Light) <sup>(2)</sup>	Less than 300	8	8
	(Medium) <sup>(2)</sup>	300-400	9	12
	(Heavy) <sup>(2)</sup>	400-800	10	14
Torch brazing		—	—	3 to 4
Torch soldering		—	—	2
Carbon arc welding		—	—	14

### PLATE THICKNESS

	in.	mm		
Gas welding				
	Light	Under 1/8	Under 3.2	4 or 5
	Medium	1/8 to 1/2	3.2 to 12.7	5 or 6
Heavy	Over 1/2	Over 12.7		6 or 8
Oxygen cutting				
	Light	Under 1	Under 25	3 or 4
	Medium	1 to 6	25 to 150	4 or 5
Heavy	Over 6	Over 150		5 or 6

<sup>(1)</sup> As a rule of thumb, start with a shade that is too dark, then go to a lighter shade which gives sufficient view of the weld zone without going below the minimum. In oxyfuel gas welding or cutting where the torch produces a high yellow light, it is desirable to use a filter lens that absorbs the yellow or sodium line the visible light of the (spectrum) operation

<sup>(2)</sup> These values apply where the actual arc is clearly seen. Experience has shown that lighter filters may be used when the arc is hidden by the workpiece.