

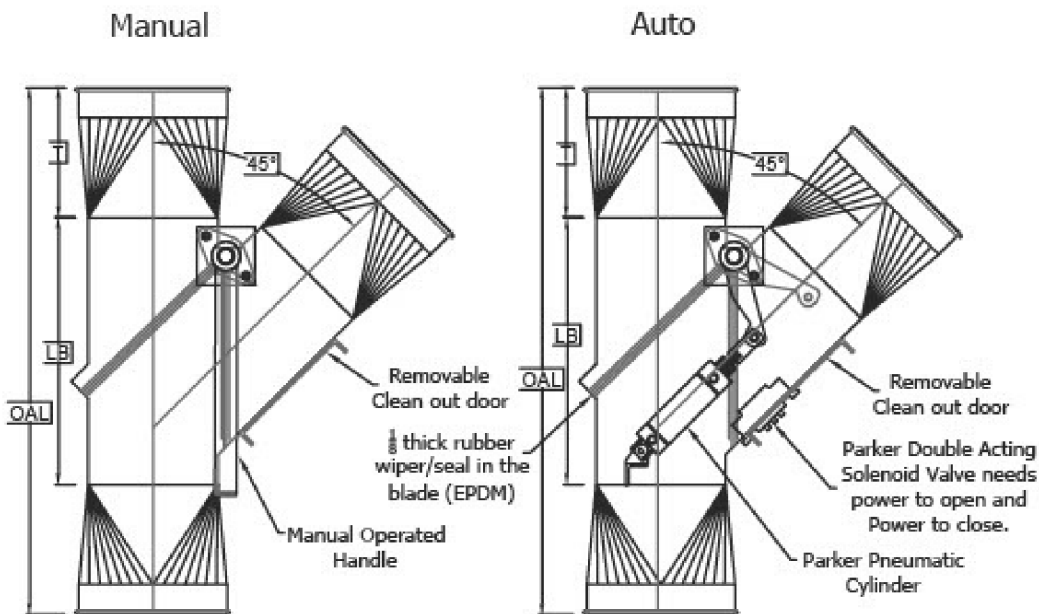

Automatic and Manual Diverter Valves

Redirect or divert the airflow in different directions or to different areas within your ductwork system with our durable automatic and manual diverter valves.

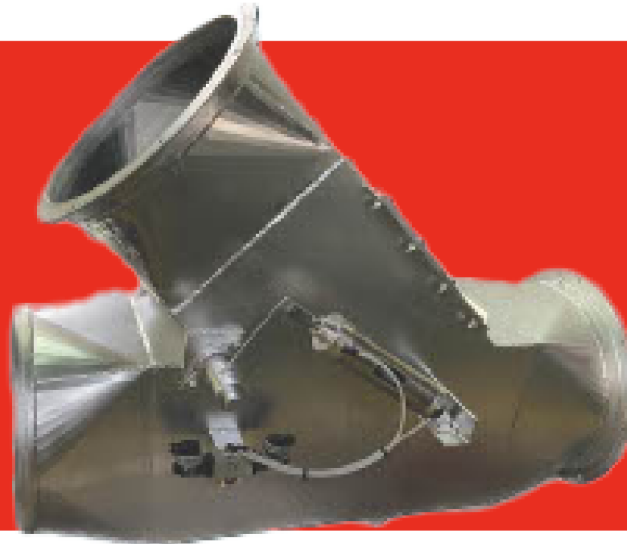

Size ϕ	Trz.	L-Body	OAL
4	7	10.5	24.5
5	7	12	26
6	7	13	27
7	7	14.5	28.5
8	7	15.5	29.5
9	7	17	31
10	9	18	36
11	9	19.5	37.5
12	9	23	41
13	9	24	42
14	9	25.5	43.5
15	9	26.5	44.5
16	9	28	46
17	9	29	47
18	9	30	48
19	12	31.5	55.5
20	12	32.5	56.5
22	12	35	59
24	12	37.75	61.75

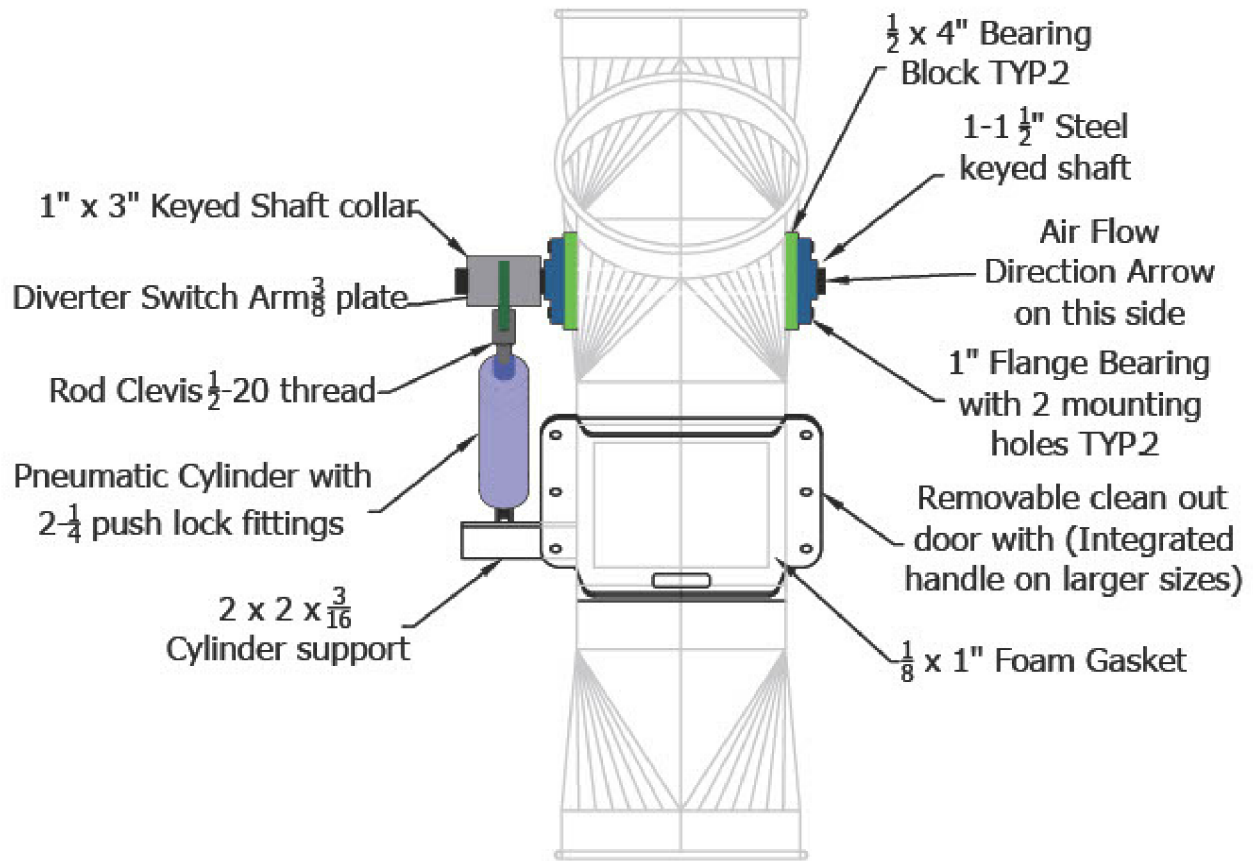

Diverter Size	Cylinder Dim.	Cylinder Stroke
4-6"	1 $\frac{1}{2}$ "	3"
7-10"	2 $\frac{1}{2}$ "	3"
11-24"	2 $\frac{1}{2}$ "	6"

Size Ø	Trz.	L-Body	OAL
26	18	42	78
28	18	44.5	80.5
30	18	46.5	82.5
32	18	49.5	85.5
34	20	52	92
36	20	55	95
38	20	57	97
40	20	59.5	99.5

Manual Arm

