



WESCO®



For All Your Material Handling Needs

www.wescomfg.com | 1-800-445-5681



**OUR
PROMISE
TO YOU**

**FULFILLING YOUR
DAILY NEEDS RELIABLY,
COMPLETELY
AND CONVENIENTLY.**



Convenience You Can Count On.

- A click or call away to fulfill your needs and keep your business moving.



Dependable Products.

- 70+ years of manufacturing professional-grade products.



Extensive Range of Solutions.

- A comprehensive catalog of the right products for the job.
- Capability to design and manufacture custom solutions for the most unique applications.

IWS is your trusted partner in material handling solutions. We offer the best selection of high-quality brands and products, empowering workplaces to be **safer**, more **efficient** and more **effective**.



DRUM HANDLING EQUIPMENT

Drum Trucks - Steel, Aluminum, <u>Stainless</u> , 4-Wheel Drum Cart, KD Drum Truck, <u>Stainless 626-D</u>	5-8
Drum Dollies - Steel, Aluminum, <u>Stainless Steel</u> & Polypropylene, Pail Truck & Pail Tipper	9-10
Drum Trucks, Carriers, Dispensers	11
Drum Racks, Cradles.....	12
Drum Lifters, Steel & <u>Stainless Steel</u> , Drum Sling	13
Ergonomic Drum Lifters, Steel & <u>Stainless Steel</u> , Manual, Scale, Powered, High Reach.....	14
Ergonomic Drum Tilters, Steel, Manual, Powered, High Reach	15
Drum Dispensers, Triple Truck Drum Attachment	16
Gator Grip Drum Grab	17
Fork Drum Grabs, Fork Truck Drum Dispensers, Poly Drum Lifters	18
FM Approved Drum Faucets, Plastic Drum Faucets.....	19
FM Approved Drum Vent, Wires, Gauges, Funnel, Pop-Up Gauges.....	20
Drum Deheaders & Wrenches.....	21
Drum Pumps & Drip Pans, <u>Stainless Steel</u> Rotary Pump	22

HAND TRUCKS

Industrial Duty Steel Hand Trucks, <u>Stainless Steel</u> Hand Truck.....	23-24
Touch-N-Tilt, Drum Hand Trucks, <u>Stainless Steel</u> Drum Truck, 4-Wheel Drum Cart	25
Heavy Duty Steel Hand Trucks	26
Heavy Duty Warehouse and Convertible Hand Trucks	27
Standard Duty Steel Hand Trucks	28
Economy, Convertible Hand Trucks, Curb Ramp	29
Cylinder Carts and Trucks, Power Drive Large Liquid Cylinder Cart.....	30-31
Aluminum Cobra-Lite Hand Trucks, Options, Components, Handles	32-35
Aluminum Cobra Convertible, Spartan Economy Convertible, Spartan III	36-37
Powered CobraPro	38
Power LiftKar, StairKing Stairclimbing Trucks, Options.....	39-43
Vending & Appliance Trucks, Steel & Aluminum, Standard & Heavy Duty	43-45

PALLET TRUCKS

Deluxe Pallet Trucks	46-47
Advantage™ Pallet Trucks	48-49
CP Pallet Trucks	50-51
Advantage™ Power Pallet Trucks	52-53
Specialty Pallet Trucks	54-56
Manual, Electric High Lifts, Steel, <u>Stainless</u>	57
Pallet Jack Stop, Pallet Truck Chock, 3 in 1 Adapter, Backrest Guards	58

LIFT EQUIPMENT

Steel Pedalifts: Winch & Hydraulic Lifters, <u>Stainless</u> Pedalifts	59-60
Special Application Hydraulic & Winch Lifts.....	61
Triple Truck, Aluminum Pedalifts	62
Hand Winch Lifts, Premium Light Weight Duty Winch Lift	63
Platform Stackers, 1,000 lb Winch Stackers.....	64
Manual & Power Drum Rotators.....	65
Fork Stackers, 1,000 lb	66
Value Office Lifts and Stackers, Options	67
2,200 lb Power Drive & Counter-Balance Stackers	68
1,000, 1,500, 2,000 lb Powered Stackers-Platform, Fork, Adjustable, Telescoping, Dual Platform Stacker.....	69-71
Wesco®, Lexco® Hydraulic Lift Tables, Lexco Die Handlers, Roller & Ball Transfer Tops	72-78
Precision Lift Tables.....	78
Scissors Lift Tables, Double Scissors Table, Long Deck Tables.....	79-80
Powered Lift Scissors Tables.....	81
Pallet Levelers, Spring & Pneumatic	82
Rais-N-Rol™ Machinery Movers, Furniture Movers & Trolleys	83-84

PLATFORM TRUCKS, CARTS & DOLLIES

Platform Trucks - Aluminum, Steel Grid, Steel, Panel Cart, Power Drive, Wood Dollies.....	85-88
Wire Cage & Panel Carts.....	89
U-Boats; Aluminum, Steel, Wood, Shelf Option	90
Folding-Handle Platform Trucks; Steel, Aluminum, <u>Stainless</u>	91-92
Steel, <u>Stainless Steel</u> Carts	93
Plastic Platform Trucks	94
Wire Basket & Table Top Office Carts.....	95
Lightweight Folding Trucks	96
Tilt Carts	97
Polyethylene Tub Carts.....	98

DOCK AND SHIPPING EQUIPMENT, WIRE SHELVING AND WHEELS

Dock Seals	99
Strapping Truck & Tools, UL Approved Dock Lights	100
Trailer Stabilizing Jacks	101
Fork Extensions, Maintenance Platform, Battery Transfer Cart, Trolleys	102
Wheels.....	103

IWS PARTNER COMPANIES

Bluff Manufacturing.....	104-105
Nordock Inc.	106-107

DRUM TRUCK FEATURES:

Heavy duty, double welded joints, 1" structural steel frame, and kickstands to store upright.



USA 5BT & 5BTW Economy Series

- Kickstand.
- With wheels resting on floor, 22" to center of lowered chime hook.
- **Steel drums only.**
- Handles 55 & 85 gallon steel drums.

OVERALL DIMENSIONS

w: 24.5"
h: 62"
d: 17"

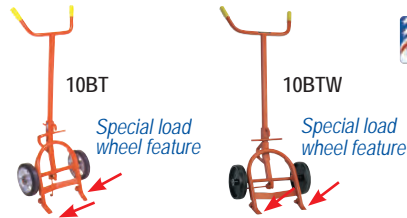

USA 10BT & 10BTW Standard Series

- Machined steel load wheels behind nose prongs help ease the lifting of the drum.
- With wheels resting on floor, 22" to center of lowered chime hook.
- **Steel drums only.**
- Handles 55 & 85

OVERALL DIMENSIONS

w: 24.5"
h: 61"
d: 14.5"



USA 15BT & 15BTW Deluxe Series

- Four wheel design enables user to quickly and easily load and unload drums from pallet.
- With two wheels resting on floor, 20.5" to center of lowered chime hook.
- Replaceable hard faced double-beveled nose prongs, Part # 240060.
- **Steel drums only.**
- Handles 30, 55 & 85 gallon steel drums.

OVERALL DIMENSIONS

w: 24"
h: 58"
d: 21"



USA 15BTC Ergonomic Drum Truck

- Ergonomic swivel caster design reduces operator muscle strain and fatigue.
- With two wheels resting on floor, 20.5" to center of lowered chime hook.
- Replaceable hard faced double-beveled nose prongs, Part # 240060.
- **Steel drums only.**
- Handles 30, 55 & 85 gallon steel drums.

OVERALL DIMENSIONS

w: 24"
h: 58"
d: 21"



USA 20BT & 20BTW- Deluxe Series

- Floating axle reduces effort required to break over and balance load.
- Chime hook can be stored at the top of the frame for easy use.
- Replaceable hard faced double-beveled nose prongs, Part # 240060.
- **Steel drums only.**
- Handles 30, 55 & 85 gallon steel drums.

OVERALL DIMENSIONS

w: 23.5"
h: 60"
d: 17"



Part # Model #	240009 5BT	240010 5BTW	240013 10BT	240014 10BTW	240001 15BT	240002 15BTW	240121 15BTC	240003 20BT	240004 20BTW
Capacity	1,000 lbs	1,000 lbs	1,000 lbs	1,000 lbs	1,000 lbs	1,000 lbs	1,000 lbs	1,000 lbs	1,000 lbs
10" Wheel	Moldon Rubber	Polyolefin	Moldon Rubber	Polyolefin	Moldon Rubber	Polyolefin	Moldon Rubber	Moldon Rubber	Polyolefin
6" Wheel	N/A	N/A	N/A	N/A	Moldon Rubber	Polyolefin	Moldon Rubber	N/A	N/A
Weight	68 lbs	53 lbs	64 lbs	50 lbs	79 lbs	61 lbs	79 lbs	74 lbs	59 lbs



DRUM TRUCK FEATURES:

Heavy duty, double welded joints, 1" structural steel frame, and self standing or kickstands to store upright.



30BT & 30BTW - Standard Series

- Multi-functional drum truck allows you to move drums on four wheels and acts as a drum cradle for storage or dispensing.
- 16.5" drain height.
- With two wheels resting on floor, 28" to bottom of lowered chime hook.
- **Steel drums only.**
- Handles 30, 55 & 85 gallon steel drums.

OVERALL DIMENSIONS

w: 24"
h: 56"
d: 20.5"

6" x 1 1/2" wheel



40BT & 40BTW Series

- Handles all poly and fiber drums except overpacks (use 45BT for overpacks).
- Replaceable feet - Part# 240115 and replaceable belt - Part# 150303.
- Floating axle reduces effort required to break over and balance load.
- With wheels resting on floor, 28" to bottom of belt.
- Handles 30, 55 & 85 gal. drums.
- **Steel, poly & fiber drums.**

OVERALL DIMENSIONS

w: 23.75"
h: 59.75"
d: 24"



45BT & 45BTW Series

- Recommended primarily for handling of overpacks.
- Wide "feet" eliminate the risk of drums being punctured by nose prongs.
- Replaceable feet - Part # 240115 and replaceable belt - Part # 150304.
- Floating axle reduces effort required to break over and balance load.
- With wheels resting on floor, 28" to center of belt.
- Handles 30, 55 & 85 gal. drums.
- **Steel, poly & fiber drums.**

OVERALL DIMENSIONS

w: 24"
h: 59.75"
d: 24"



50BT & 50BTW Series

- Acts as a Poly Drum Truck or Drain Stand.
- Wide "feet" and belt eliminate the risk of drums being punctured by nose prongs and chime hooks.
- With two wheels resting on floor, 32" to center of belt.
- Handles all poly drums (except overpacks).
- Handles 30, 55 & 85 gal. drums.
- **Steel, poly & fiber drums.**

OVERALL DIMENSIONS

w: 24"
h: 57.5"
d: 25"

Rear wheels on 50BT - Aluminum Ctr.
Moldon Rubber Rear wheels on 50BTW - Polyolefin

Part # Model #	240005 30BT	240006 30BTW	240081 40BT	240076 40BTW	240082 45BT	240077 45BTW	240083 50BT	240078 50BTW
Capacity	1,000 lbs	1,000 lbs	1,000 lbs	1,000 lbs	1,000 lbs	1,000 lbs	1,000 lbs	1,000 lbs
10" Wheel	Moldon Rubber	Polyolefin	Moldon Rubber	Polyolefin	Moldon Rubber	Polyolefin	Moldon Rubber	Polyolefin
6" Wheel	Moldon Rubber	Polyolefin	N/A	N/A	N/A	N/A	Moldon Rubber	Polyolefin
Weight	82 lbs	66 lbs	82 lbs	67 lbs	82 lbs	67 lbs	86 lbs	65 lbs



BT BTW
10" x 2.5" 10" x 2.25"
Cast Iron Center Polyolefin
Moldon Rubber
150596150691



240120

Manual Aluminum Drum Trucks



- Spring loaded chime hook automatically engages drum.
- Two wheel choices: 10" Moldon Rubber on Aluminum Hub or 12" Pneumatic Steel Hub.
- Disc wheel brake activated by hand lever: B: with brake. NB: no brake.
- Steel, poly and fiber drums.

- 30 and 55 gallon drums.
- Two chime hooks available:
SCH: standard hook for closed head steel, fiber and poly drums (SC). (Not for use on drums with locking ring or 85 gallon size.)
LCH: special order hook for steel, fiber and poly drums with locking rings. Can be used on 85 gallon drums (LC).

OVERALL DIMENSIONS

w: 25.875" | h: 60" | d: 18.5"

LCH - Hook for Steel, Fiber, Poly Drums & 85 Gallon Drums

Part # Model #	240124 ABT-10-SC-B	240132 ABT-10-SC-NB	240120 ABT-12-SC-B	240134 ABT-12-SC-NB	240133 ABT-10-LC-NB	240119 ABT-12-LC-B
Capacity	1,000 lbs	1,000 lbs	1,000 lbs	700 lbs	1,000 lbs	1,000 lbs
Brake	Yes	No	Yes	No	No	Yes
Wheels	10" Moldon Rubber Rear 6" Moldon	10" Moldon Rubber Rear 6" Moldon	12" Pneumatic Rear 6" Moldon	12" Pneumatic Rear 6" Moldon	10" Moldon Rubber Rear 6" Moldon	12" Pneumatic Rear 6" Moldon
Weight	60 lbs	60 lbs	60 lbs	60 lbs	60 lbs	60 lbs



#240016

US PATENT NO. 9,302,688



#240019 WITH (#240211), OPTIONAL 3RD WHEEL, 304 STAINLESS STEEL



#240017



#240017 WITH (#240210) OPTIONAL 3RD WHEEL

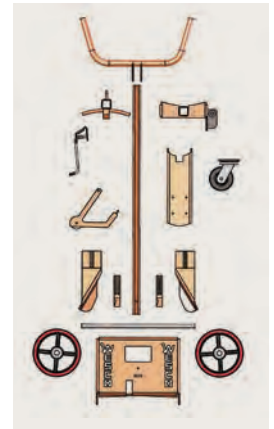

Knock Down (KD) Drum Trucks



- UPSable - KD and boxed.
- Six models: (4) Steel and (2) 304 Stainless Construction.
- Handles 30, 55 and 85 gallon drums.
- Models to handle steel and poly drums.
- Requires minimal assembly.
- All parts removable and interchangeable.
- Each of the six models include handle, frame, base, kickstand, axle, toe or feet, wheels, chime hook or belt and hardware.
- Foot operated break-over assist bar provides extra leverage to tilt and balance load and allows truck to rest in tilt-back position.
- Stainless models okay for wash down.

Optional 3rd Wheel:

- Ergonomic design, better maneuverability.
- Better load support.
- Helps reduce breakover effort.
- 5" x 2" swivel caster.
- Two Models: #240210 for steel trucks, 13 lbs.
#240211 for 304 stainless trucks, 14 lbs.

Part # Model #	240016 KD-STL-STL-PU	240017 KD-STL-POLY-PU	240052 KD-STL-STL-PO	240053 KD-STL-POLY-PO	240019 KD-SS-STL-PO	240020 KD-SS-POLY-PO
Capacity	1,000 lbs	1,000 lbs	1,000 lbs	1,000 lbs	1,000 lbs	1,000 lbs
Wheel	10" x 2.5" Polyurethane	10" x 2.5" Polyurethane	10" Polyolefin	10" Polyolefin	10" Polyolefin	10" Polyolefin
Drum Type Handled	Steel	Poly	Steel	Poly	Steel	Poly
Toe/Foot (replaceable)	Milled Toe #240060	Formed Foot #240115	Milled Toe #240060	Formed Foot #240115	Stainless Milled Toe #051904	Stainless Foot #050362
Construction	Steel	Steel	Steel	Steel	304 Stainless	304 Stainless
Chime Hook	#240214 - steel	N/A	#240214 - steel	N/A	#050197 - stainless	N/A
Belt	N/A	#240212 - steel ratchet assembly	N/A	#240212 - steel ratchet assembly	N/A	#240213 - stainless buckle
Weight	70 lbs	78 lbs	63 lbs	71 lbs	66 lbs	75 lbs





4-Wheel Drum Cart 

- Two position, 4-wheel transport design to handle drums and standard loads.
- Position I:** Easily handles and maneuvers standard loads as a 4-wheel transport.
- Position II:** With the chime hook engaged and a press of the foot pedal, the frame tilts a 30 or 55 gallon steel drum to a balanced position to maintain 4-wheel contact even with half empty bottom heavy drums.
- Two 3.5" x 1.5" polyolefin swivel casters for easy maneuverability in narrow spaces.
- Chime hook to engage 30 & 55 gallon steel drums.
- 7.8" D x 14" W beveled edge noseplate.
- Curved frame holds 5-gallon pails and kegs.

OVERALL DIMENSIONS

w: 19.25" | 19.25"
h: 48" | 48.5"
d: 26.25" | 25"



156DH-Z



156DH-PP8-SS
304 STAINLESS STEEL



156DH Drum/Hand Truck 

- Utility of a hand truck and drum truck.
- Chime hook works with 55 and 30-gallon steel drums.
- Curved frame holds 5-gallon pails and kegs.
- With noseplate resting flat on floor, 15.5" to center of lowered chime hook.
- Noseplate 7.8" D x 14" W.
- 304 stainless steel model #210352.
- Stainless model has 8" polyurethane, non-marking wheels with stainless precision ball bearings.

OVERALL DIMENSIONS

w: 20.5" | 20.5" | 20.5" | 20.5"
h: 48" | 48" | 48" | 48"
d: 18.5" | 17.5" | 18.5" | 18.5"



Series 626D-SS

- Stainless steel model 7.5" deep x 13.75" wide 7 gauge beveled nose plate with radiused corners for safety.
- Continuous frame loop.

304 STAINLESS STEEL

OVERALL DIMENSIONS

w: 17.25"
h: 52"
d: 18"

Part # Model #						Stainless	Stainless
	210353 4WDC-ZC	210354 4WDC-HBC	210340 156DH-Z	210349 156DH-HB	210266 156DH-P	210352 156DH-PP8-SS	210362 626D-SS
Capacity	800 lbs	900 lbs	700 lbs	800 lbs	700 lbs	600 lbs	500 lbs
Wheels	10"/ Z	8"/ HB	Z	HB	P	8" Polyurethane	SR -10" Solid Rubber
Weight	66 lbs	66 lbs	39 lbs	42.5 lbs	39 lbs	33.5 lbs	24 lbs





SS5-PPSS

All stainless rigs with 3" polypropylene wheels

Stainless Steel Drum Dollies

- **Wesco's Stability Advantage.** By design, Wesco casters are mounted past the dolly and drum rim. Our casters are mounted further apart than standard designs with casters completely underneath the drum and closer together.
- The further the casters are apart the greater the stability. Welded 304 stainless steel dolly construction with reinforced outriggers.
- 304 stainless steel dollies are ideal for clean room, pharmaceutical, food and wash down applications.

- Models available for 30, 55, and 85 gallon drums.
- Three caster set options:
HRZ: zinc plated swivel rig with 3" hard rubber wheel & zinc plated hardware
***HRSS:** 304 stainless steel swivel rig with 3" hard rubber wheel & stainless hardware
***PPSS:** 304 stainless steel swivel rig with 3" white polypropylene wheel & stainless hardware.

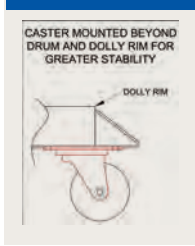

ASSEMBLED OVERALL DIMENSIONS SS3			ASSEMBLED OVERALL DIMENSIONS SS5			ASSEMBLED OVERALL DIMENSIONS SS8		
w:	24"		w:	28.5"		w:	31.5"	
h:	6"		h:	6"		h:	6"	
d:	24"		d:	28.5"		d:	31.5"	

Part # Model #	240192 SS3-HRZ	240193 SS3-HRSS	240194 SS3-PPSS	240195 SS5-HRZ	240196 SS5-HRSS	240197 SS5-PPSS	240198 SS8-HRZ	240199 SS8-HRSS	240200 SS8-PPSS
Capacity	900 lbs	900 lbs	1,000 lbs	900 lbs	900 lbs	1,000 lbs	900 lbs	900 lbs	1,000 lbs
I.D.	19"	19"	19"	24"	24"	24"	27"	27"	27"
Drum Size	30 gal	30 gal	30 gal	55 gal	55 gal	55 gal	85 gal	85 gal	85 gal
Caster Rig	Zinc plate 4 swivel	Stainless 4 swivel	Stainless 4 swivel	Zinc plate 4 swivel	Stainless 4 swivel	Stainless 4 swivel	Zinc plate 4 swivel	Stainless 4 swivel	Stainless 4 swivel
3" Caster Wheel	Hard Rubber	Hard Rubber	White Polypropylene	Hard Rubber	Hard Rubber	White Polypropylene	Hard Rubber	Hard Rubber	White Polypropylene
Dolly Material	304 Stainless	304 Stainless	304 Stainless	304 Stainless	304 Stainless	304 Stainless	304 Stainless	304 Stainless	304 Stainless
Weight	20 lbs	20 lbs	18 lbs	22 lbs	22 lbs	21 lbs	24 lbs	24 lbs	23 lbs

Steel Drum Dollies



D5-SI



4 swivel casters.

- **Wesco's Stability Advantage.** By design, Wesco casters are mounted past the dolly and drum rim. Our casters are centered under the dolly rim and further apart than standard designs which are inside the rim and closer together. The further the casters are apart, the greater the stability.
- All welded steel frame construction with reinforced outriggers.
- Four bolt on 3" swivel casters.
- I.D. varies among models.
- Models available for 30, 55, and 85 gallon drums.

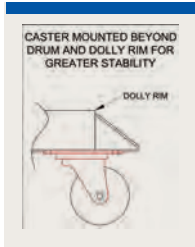

ASSEMBLED OVERALL DIMENSIONS - D3		ASSEMBLED OVERALL DIMENSIONS - D5		ASSEMBLED OVERALL DIMENSIONS - D8	
w:	24"	w:	28.5"	w:	31.5"
h:	6"	h:	6"	h:	6"
d:	24"	d:	28.5"	d:	31.5"

Part # Model #	240028 D3-SI	240029 D3-HR	240030 D5-SI	240031 D5-HR	240088 D8-SI	240089 D8-HR
Capacity	1,000 lbs	900 lbs	1,000 lbs	900 lbs	1,000 lbs	900 lbs
I.D.	19"	19"	24"	24"	27"	27"
Drum Size	30 gal	30 gal	55 gal	55 gal	85 gal	85 gal
Caster Rig	Zinc plate 4 swivel	Zinc plate 4 swivel	Zinc plate 4 swivel	Zinc plate 4 swivel	Zinc plate 4 swivel	Zinc plate 4 swivel
3" Caster Wheel	Sintered Iron	Hard Rubber	Sintered Iron	Hard Rubber	Sintered Iron	Hard Rubber
Dolly Material	Steel	Steel	Steel	Steel	Steel	Steel
Weight	18 lbs	18 lbs	24.5 lbs	22 lbs	26 lbs	26 lbs



Polypropylene Dolly

- 5 swivel casters, 3" polyolefin wheels.
- Handles 30 or 55 gallon drums.
- Rigid latticed understructure for strength.

OVERALL DIMENSIONS

w: 24.25"
h: 7.125"
d: 24.25"



2 rigid and 2 swivel casters.

RSD



*Model SSD with drain plug and handle.

SSD



RAOD



RASD



Specialty Dollies

- 3" hard rubber caster.
- Steel or aluminum designs.

OVERALL DIMENSIONS

w: 24.5"	25.75"	24.5"	24.5"
h: 6"	6"	6"	6"
d: 24.5"	24.5"	24.5"	24.5"



PT

PT Pail Truck

- Handles up to four standard steel or plastic 5-gallon pails.
- Ergonomic design eliminates the need to stack pails on a noseplate.
- 10" Semi-Pneumatic - #150589.

OVERALL DIMENSIONS

w: 26"
h: 55"
d: 21"

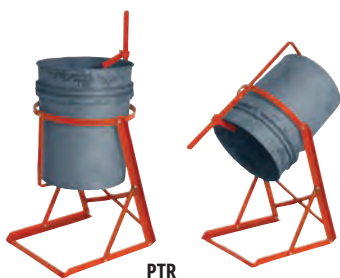

PTR

Pail Tipper

- Adjustable chime hook.
- Ships KD easy assembly.
- Boxed dimensions 16.5"W x 22"D x 3"H.
- For dispensing 5 gal. steel or plastic pails.

OVERALL DIMENSIONS

w: 14.5"
h: 30"
d: 14.5"

Part # Model #	240201 P55-30-P	240033 RSD	240040 SSD*	240043 RASD	240044 RAOD
Capacity	900 lbs	900 lbs	900 lbs	900 lbs	900 lbs
I.D.	23.25"	24"	23.625" sq.	24"	24"
Drum Size	30 or 55 gal	55 gal	30 or 55 gal	30 or 55 gal	30 or 55 gal
Caster Rig	Zinc Plate 5 Swivel	Zinc plate 2 Rgd./2 Sw.	Zinc plate 4 swivel	Zinc plate 4 swivel	Zinc plate 4 swivel
3" Caster Wheel	Polyolefin	Hard Rubber	Hard Rubber	Hard Rubber	Hard Rubber
Dolly Material	Polypropylene	Steel	Steel	Aluminum	Aluminum
Weight	17 lbs	22 lbs	47 lbs	20 lbs	14 lbs

Part # Model #	240042 PT	273108 PTR
Capacity	500 lbs	70 lbs
Brake	N/A	N/A
Wheels	Semi-Pneumatic	N/A
Weight	40 lbs	10 lbs



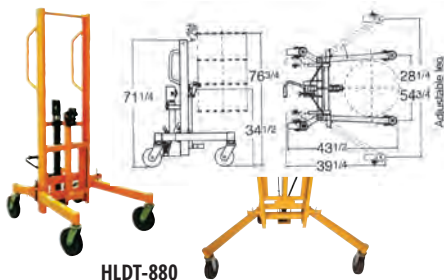

High-Lift Hydraulic Drum Truck

- Handles 55, and 85 gallon drums.
- Easy width adjustment to accommodate a variety of pallets.
- Four 7" moldon polyurethane swivel casters.
- Locking rear casters.
- Works with most rimmed steel and poly drums.
- Not for use with open head drums or drums with lid rings.

OVERALL DIMENSIONS

w: 54.75"
h: 71.25"
d: 43.5"

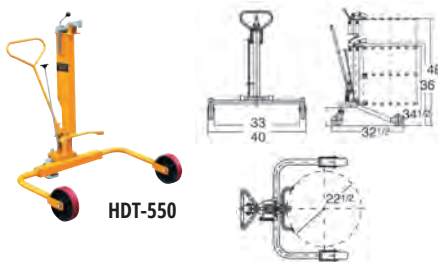

Economy Hydraulic Drum Truck

- Handles steel drums up to 22½" in diameter.
- 2 rigid and 1 swivel locking caster for easy maneuverability.
- Pallet truck-type pump handle.
- Works with most rimmed steel drums.

OVERALL DIMENSIONS

w: 40"
h: 46"
d: 32.5"



Pallet Truck Drum Lifter

- Hydraulic pallet truck design to lift and move 55 gallon steel drums.
- Lowered height: 10"
- Raised height: 14.5"
- 8" x 2" nylon steering wheels.
- 1" x 3" nylon load wheels.

OVERALL DIMENSIONS

w: 28.5"
h: 47.5"
d: 42"

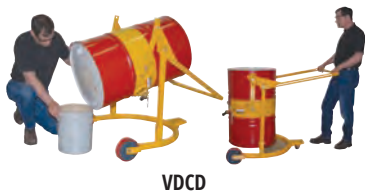

Value Drum Carrier and Dispenser

- Economically priced.
- Three height adjustments: 9.25", 10.625" and 12".
- Vertical and horizontal locking positions.
- Polyurethane wheels and casters.
- 8" x 2" wheels and 4" x 1.25" caster.
- Ships KD.

OVERALL DIMENSIONS

w: 35"
h: 65.5"
d: 37"



Spill-Less Open Drum Truck

- Transport drums in a vertical position.
- Handles 55 gallon drums.
- 8" x 2" moldon rubber wheels with roller bearings.
- 5" x 2" polyolefin swivel casters.
- All welded construction.

OVERALL DIMENSIONS

w: 32"
h: 32.25"
d: 25.25"

Part # Model #	272967 HLDT-880	272945 HDT-550	273250 PTDL	272404 VDCD	240015 500
Capacity	880 lbs	550 lbs	660 lbs	Full Drum - 800 lbs Half Drum - 500 lbs	1,000 lbs
Wheels	(4) 7.5" Polyurethane Swivel	(2) 8" Polyurethane Wheels (1) 5" Polyurethane Caster	(2) 8" x 2" Nylon Steering Wheels (2) 1" x 3" Nylon Load Wheels	(2) 8" x 2" Polyurethane Wheels (1) 4" x 1.25" Polyurethane Caster	(2) 8" x 2" Moldon Rubber w/ Roller Bearings (1) 5" x 2" Polyolefin Swivel Caster
Lift Height	76.75" to top of drum 42.5" to bottom of 34.5" steel drum	48" to top of drum 13.5" to bottom of 34.5" steel drum	N/A	N/A	N/A
Lift	0.45" per stroke	0.87" per stroke	N/A	N/A	N/A
Leg Span Adjustment	28.25" - 54.75"	N/A	N/A	N/A	N/A
Lift Range	42.5"	13.5"	N/A	N/A	N/A
Weight	220 lbs	99 lbs	115 lbs	105 lbs	70 lbs



Drum Racks

- Two and three 55 gal. steel drum models.
- Four-side fork truck entry.
- Can be stacked 4 high.
- Standard models ship knocked down and boxed via UPS.
- Quick and easy to assemble.
- Welded and bolted construction.

OVERALL DIMENSIONS

w: 45.5" 71.5"
h: 12.5" 12.5"
d: 30" 30"



Deluxe Drum Cradle

- Tips, drains, stores, rotates and moves 30 or 55 gallon steel drums.
- Dual telescoping wood handles allow easy two handed control.
- Large 4" x 1.25" polyolefin wheels for easy movement over uneven floors.
- Shipped knocked down and boxed via UPS.
- **Backed by 2 year warranty against weld failure.**
- Drip tray option available.

OVERALL DIMENSIONS

w: 19"
d: 43" - 67.375"
h: 25.5"
20" drain height

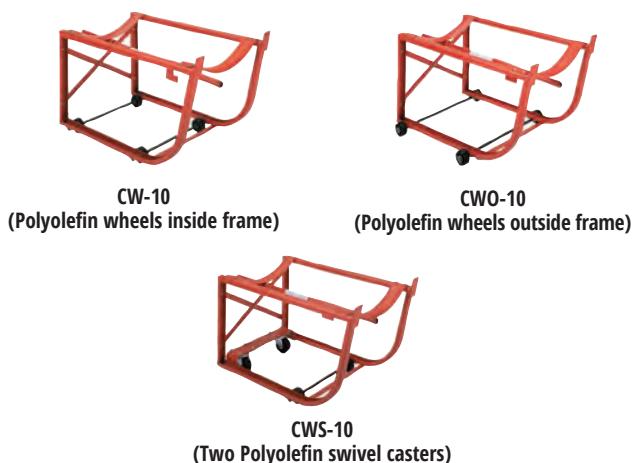

Standard Steel Drum Cradles

- Economical and convenient way to tip, drain and store 55 gallon steel drums.
- Easy for one person to use.
- All models ship knocked down and boxed via UPS.
- Models available with 2.5" polyolefin wheels, self-storing load tipping lever, and swivel casters.
- Drip tray option available for all models.

OVERALL DIMENSIONS

w: 19.5"
d: 32.5"
h: 15" on wheeled models
13.5" on non-wheeled models

Part # Model #	240026 DR-2	240027 DR-3	240025 CW-20	240022 CW-10	240023 CWO-10	240024 CWS-10
Capacity	1,600 lbs (2 drums)	2,400 lbs (3 drums)	1,000 lbs	600 lbs	600 lbs	600 lbs
Wheels	N/A	N/A	(4) 4" x 1.25" Polyolefin Wheels	(4) 2.5" Polyolefin Wheels	(4) 2.5" Polyolefin Wheels	2.5" Polyolefin: (2) Wheels (2) Casters
Weight	49 lbs	64.5 lbs	50 lbs	30 lbs	32 lbs	34 lbs



Drip Tray

- Steel slide-out tray 9.75" x 9.75" with 1.75" lip.
- Fits all Wesco drum cradles.
- Polyethylene pan.
- Cellulose absorbent holds 3 quarts of liquid.

CW-10 With Optional Drip Tray

Part #
Model #

270413
DT

270414
DP

Weight

7.5 lbs

1 lb



EDL-5

Economy Drum Lifter



- Lightweight and easy to use.
- Lock pin design holds drum firmly in place.
- Ships boxed via UPS.
- For use with closed head 55 gallon steel drums.

OVERALL DIMENSIONS

w: 23.5"
h: 12.5"
d: 25.5"



Open head steel

Closed head steel

Open head poly

Salvage Drum Lifters



- Convenient for fast and gentle loading of steel drums into overpacks.
- Ships boxed via UPS.
- For use with closed head steel drums.

OVERALL DIMENSIONS

w: 29.5"
h: 5.5"
d: 29.5



UDL
NOW AVAILABLE IN
304 STAINLESS STEEL



Universal Drum Lifter



- Two models - UDL: carbon steel | UDL-SS: 304 stainless steel.
- Design allows for theloading of drums into overpacks.
- Works on open and closed head drums.
- For use with standard steel or poly drums with at least a 3/16" chime.
- Lifting arms are adjustable to work with most 55 or 30 gallon drums.
- Three-point contact of the lifting arms prevents or minimizes deformation of the drum and provides more secure lifting.

OVERALL DIMENSIONS

w: 29.5" 29.5"
h: 5.5" 5.5"
d: 29.5 29.5



SDL-55



SDL-85

Open Head Drum Lifters



- For use with standard steel or poly drums with at least a 3/16" chime.
- Lifting arms are adjustable to work with most 55 or 30 gallon drums.
- Three-point contact of the lifting arms prevents or minimizes deformation of the drum and provides more secure lifting.
- Also works on closed head drums.

OVERALL DIMENSIONS

w: 9.875" 9.875"
h: 7.375" 7.375"
d: 19.63" 19.63"



DRL-3

Hoist Mount Drum Lifter

- Heavy duty annealed ductile iron.
- Curved foot on stabilizing arm prevents damage to drum.

OVERALL DIMENSIONS

w: 24.5"
h: 17.5"
d: 2.25"



DLS Drum Sling
440009 (steel)

Drum Sling

- Horizontally lift all "closed or open-head" drums.
- D-shaped lifting ring fits most overhead systems.
- Inverted ring fits web-lifting slings.

OVERALL DIMENSIONS

w: 2.25"
h: 18.75"
d: 2"

Stainless

Part # Model #	240057 EDL-5	240038 OHDL-3	240062 UDL	240063 UDL-SS	240100 SDL-55	240102 SDL-85	440001 DRL-3	440009 DLS-1000
Capacity	700 lbs	1,000 lbs	1,000 lbs	1,000 lbs	1,000 lbs	1,000 lbs	3,000 lbs	1,000 lbs (Steel)
Weight	17 lbs	18 lbs	20 lbs	21 lbs	20 lbs	18 lbs	37 lbs	5 lbs



FIVE MODELS ALL WITH U.S. PATENTED GATOR GRIP®

U.S. PATENT NO. 6,619,905



Standard Model



Power Lift



High Reach Model



Scale Model - Accuracy ±0.50% of applied load or 1 lb., whichever is greater.

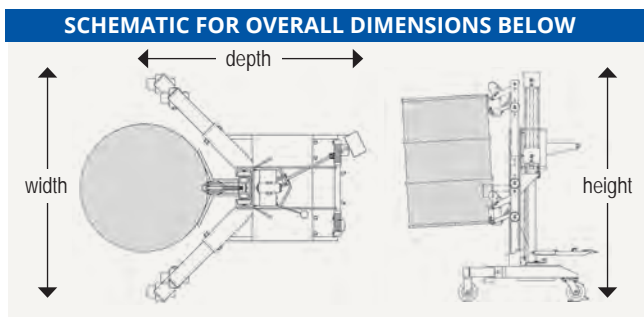

Wesco® Ergonomic Drum Handlers



- 1 Year Warranty, parts only.
- WESCO MADE hydraulic pump - all models.
- Handles most 30, 55 or 85 gallon drums - Steel, Fiber and Poly.
- Works with most drums with locking rings.
- Up/Down remote on power units.
- Power drive travel speed 120'/min.
- Lifts, transports, weighs and places drums on spill or standard pallets.
- (6) models: (5) steel and (1) 304 Stainless Steel.
- The (5) steel models are standard with the Gator Grip® Drum Clamp:
 - Spring-loaded jaws hold any 3/16" or higher drum rim.
 - Operator does not need to touch drums to operate.
 - Exclusive auto grip lock will not drop a drum if operated properly.
 - (2) wheels and (2) swivel casters, 5" x 2" phenolic, and floor lock.



Power Lift & Drive



304 Stainless Steel Drum Handler

- The 304 Stainless Steel SSDH model features:
 - Wesco manufactured 304 Stainless Steel construction hydraulic jack.
 - 304 Stainless Steel automatic Grab that grips drum rim and can be manually locked down for lift and travel.
 - (2) 5" x 2" black phenolic wheels with 304 Stainless Steel roller bearings.
 - (2) 304 Stainless Steel NSF certified washdown swivel casters with 5" x 2" black phenolic wheels, 304 Stainless Steel bearings.
 - Works with most drums with locking rings.
 - Lift range: 26" - 73" at lifting clamp.
 - Single position outriggers - non-telescoping.
 - 304 Stainless Steel construction includes hydraulic pump, floor lock, clamp, casters and bearings.
 - Handles most 30, 55 and 85 gallon steel, poly and fiber drums.

OVERALL DIMENSIONS

w:	41"	42"	41"	41"
h:	54"	54"	73"	73"
d:	39"	43"	53"	53"

Part # Model #	240150 DM-1100	240155 DM-1100-S	240156 DM-1100-PL	240157 DM-1100-PLD
Description	Standard	Scale	Power Lift	Power Lift & Drive
Rise/Stroke	1"	1"	8.5" / sec. without load	8.5" / sec. without load
Legs Retracted Capacity	650 lbs	650 lbs	650 lbs	650 lbs
Legs Extended Capacity	1100 lbs	1100 lbs	1100 lbs	1100 lbs
Drum Clamp Type	Gator Grip®	Gator Grip®	Gator Grip®	Gator Grip®
Weight	355.5 lbs	356 lbs	531 lbs	691 lbs



DM-800-MDT-Standard
Part# 240189



Manual Drum Tilter w/
Removable Tilt Handle



DM-800-MDT-High Reach
Part# 240128



DM-800-MDT-Power Models
Part# 240129 (Power Lift)
Part# 240130 (Power Lift & Drive shown)



Gear Drum Tilter w/
Crank Handle



DM-800-MDT-High Reach
Part# 240228



DM-800-MDT-Power Models
Part# 240229 (Power Lift)
Part# 240230 (Power Lift & Drive shown)

Manual Drum Tilter w/Handle



- Combines the heavy duty quality and reliability of the DM-1100 Ergonomic Drum Lifter and adds a new option to allow the drum handler to easily lift 55 gallon steel drums and dispense the contents.
- Locks in either a horizontal or vertical position for convenient dispensing or transport.
- 41" wheel clearance (spans standard skids)
- 17"-39" Lifting Range (center of drum)
- 1' lift per stroke (foot hydraulic models)
- Removable tilt handle.
- Floor Lock standard on manual models only

OVERALL DIMENSIONS

w: 48"	48"	53"	53"
h: 61"	61"	73"	73"
d: 46.5"	46.5"	53"	53"

Gear Drum Tilter w/Crank



- This new option allows the Wesco DM-1100 to easily lift 55 gallon steel drums and dispense the contents using a crank handle.
- Crank handle lifts drums to dispensing height with 360° control.
- Handles fully-loaded drums up to 800 lbs.; half-full drums up to 500 lbs.
- 41" wheel clearance (spans standard skids)
- 17"-39" Lifting Range (center of drum)
- 1' lift per stroke (foot hydraulic models)
- 30:1 gear ratio
- 8 cranks per 90° rotation
- Floor Lock standard on manual models only

OVERALL DIMENSIONS

w: 48"	48"	48"	48"
h: 62"	77.75"	77.75"	77.75"
d: 52"	52"	52"	67"

Part # Model #	240189 DM-800-MDT	240128 DM-800-MDT-HR	240129 DM-800-MDT-PL	240130 DM-800-MDT-PLD	240227 DM-800-GDT	240228 DM-800-GDT-HR	240229 DM-800-GDT-PL	240230 DM-800-GDT-PLD
Capacity								
Full Drum	800 lbs	800 lbs	800 lbs	800 lbs	800 lbs	800 lbs	800 lbs	800 lbs
Half Drum	500 lbs	500 lbs	500 lbs	500 lbs	500 lbs	500 lbs	500 lbs	500 lbs
Rise/ Stroke	1"	1"	8.5" / sec. without load	8.5" / sec. without load	1"	1"	8.5" / sec. without load	8.5" / sec. without load
Weight	415 lbs	436 lbs	590 lbs	750 lbs	465 lbs	486 lbs	640 lbs	800 lbs



Value Drum Lifter/Dispenser

- Easily lift drum and dispense contents.
- Economical, lower capacity VALUE product.
- Ships assembled and boxed.
- Locks in horizontal or vertical position.
- Handles 55 gallon steel drums.

OVERALL DIMENSIONS

w: 8.5"
h: 36"
d: 29"



*Tipping handle
available only
on DL-55*

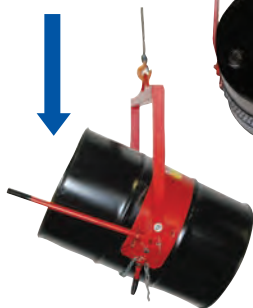

DL-55



Standard Drum Lifter/Dispenser

- Higher capacity quality product.
- Ships assembled and boxed.
- Easily lift drum and dispense contents.
- Locks in horizontal or vertical position.
- Handles 55 gallon steel drums.
- Over 25 years of proven reliable quality.

OVERALL DIMENSIONS

w: 8.5"
h: 36"
d: 29"



**Triple Truck/
Drum Attachment**

- Purchase as two parts.
- FOR COMPLETE DETAILS, SEE PAGE 62.*
- Adjustable outriggers from 11.5" I.D. to 59" I.D.

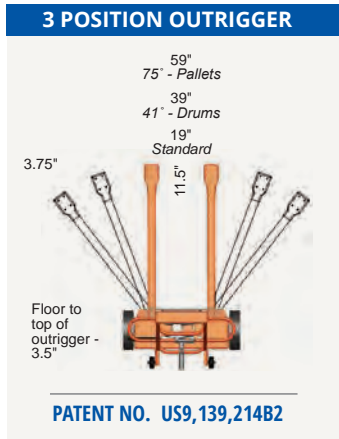

Part # Model #	278750 VDL-55	240032 DL-55	261160 & 261161 TTF+TTF-GG
Capacity Full Drum Half Drum	700 lbs 440 lbs	800 lbs 500 lbs	750 lbs. Per Grip
Weight	54 lbs	45 lbs	#261160 / 357 lbs #261161 / 32 lbs



Gator Grip®

Traditional devices require drum weight to maintain a positive lock. If a drum bounces during fork truck transportation, the drum may momentarily become weightless, which can cause the grip to snap open dropping the drum. The patented Auto Grip Lock automatically locks the jaws closed, even over rough terrain.



The Wesco Gator Grip Fork Truck Mounted Drum Grab is designed for lifting and transporting 16, 30, 55 and 85 gallon steel, fiber and poly drums.



EGG-1



Fork Truck Carriage Mount - GG-C



Single Drum Fork Mount - GG-F1



Power Stacker Mount - GGPS

- Single grip / drum attachment.
- Mounts only to Wesco fork stacker carriage.



EGG-2

- Fork truck fork attachment.
- Picks up drums automatically, driver never leaves seat while lifting or releasing drums.
- Handles steel, fiber and poly drums.
- Single and dual grips available.
- Gator Grips® made by Wesco.
- Economically priced.
- Patented Gator Grip®.



Dual Drum Fork Mount - GG-F2

- Heavy-duty carriage design.
- Single and dual grips available.
- Fork truck attachment.
- Patented Gator Grip®.



Gator Belt Option - GGBK

- Optional Gator Belt protects drum from wear.
- *Not available on egg models.*

OVERALL DIMENSIONS

w: 28"	33.25"	15.625"	32"	32"	18"	30"
h: 34"	34"	33.25"	37"	37"	33.25"	3"
d: 34"	34"	18"	28"	28"	17"	25"

Part # Model #	240091 EGG-1	240092 EGG-2	240093 GG-C	240096 GG-F1	240097 GG-F2	240103 GGPS	240107 GGBK
Capacity Per Grip	1,000 lbs	1,000 lbs	1,600 lbs	1,600 lbs	1,600 lbs	1,600 lbs	N/A
Fork Pocket ID	5.5" x 2"	7" x 2.25"	N/A	7" x 2.25"	7" x 2.25"	N/A	N/A
Weight	125.5 lbs	208 lbs	96 lbs	244 lbs	340 lbs	92 lbs	4 lbs

Note: OSHA requires contacting the manufacturer of your fork truck for written approval for the use of any fork truck attachments.



Drum Grabs for 55 Gallon Steel Drums



- All welded steel construction for durability.
- Cost effective way to move 55 gallon steel drums.

OVERALL DIMENSIONS

w:	28"	28"	46"
h:	4.75"	4.75"	7.25"
d:	42.75"	42.75"	43.25"



Adjustable Drum Grabs for 55 or 30 Gallon Steel Drums



- ADJ models feature all welded steel construction for durability.
- Handles 55 or 30 gallon steel drums.

OVERALL DIMENSIONS

w:	28"	28"
h:	5.5"	5.5"
d:	41.75"	41.75"



Value Drum Grabs

- Economically priced lower capacity grabs.
- VG models: jaws not adjustable. Handles 55 gal. steel drums.
- AVG models: adjustable jaws. Handles 30 or 55 gal. steel drums.

OVERALL DIMENSIONS

w:	28"
h:	5.5"
d:	41.75"

Part # Model #	240048 DJ-55	270051 DJL-55	240049 DJ-255	240047 ADJ-53	270084 ADJL-53	272408 SAVG-53
Capacity	1,500 lbs/drum	1,500 lbs/drum	1,500 lbs/drum	1,500 lbs/drum	1,500 lbs/drum	1,000 lbs/drum
Handles	one 55-gallon	one 55-gallon	two 55-gallon	one 55 or one 30 gallon	one 55 or one 30 gallon	one 55 or one 30 gallon
ID Fork Pocket	5.5" x 2"	7" x 2.25"	7" x 2.25"	5.5" x 2"	7" x 2.25"	5.5" x 2"
Weight	145 lbs	150 lbs	205 lbs	135 lbs	140 lbs	128 lbs



Fork Truck Drum Lifter & Tilter DGF-55



- Fork truck driver does not have to leave truck to dispense.
- Geared design allows controlled dumping and dispensing.
- Does not require any modifications to the fork truck.
- Ships assembled and boxed.
- Has 800 lbs capacity for a full drum, 500 lbs for a half full drum.
- Not for use with poly drums.
- Fork pocket dimensions (ID) 6.625"W x 2.625"H.
- Fork pocket dimensions center to center 31".
- Length of Chain 144".

OVERALL DIMENSIONS

w:	38"
h:	20.5"
d:	32.5"



Wesco Polyjaws



- Fork truck adjustable attachment for handling most 55 and 30 gallon poly drums.
- Fork truck driver does not have to leave cab to engage or disengage drum.
- Works on poly drums that have at least a 3/16" top lip (chime).
- Substantially lower priced than any other poly drum lifter on the market.
- Ships knocked down/ boxed via UPS.
- Fork pocket dimensions (ID) 5.375"W x 1.5"H.

OVERALL DIMENSIONS

w:	25.5" -29.375"
h:	6.28"
d:	21.38"



Value Fork Truck Drum Lifter & Tilter

- Economically priced lower capacity model.
- Two models, 700 & 1,400 lb capacities.
- Operator does not have to leave seat to tilt drum.
- Fork pocket dimensions (ID) 7" W x 2.5"H.
- Fork pocket dimensions center to center 31.5".
- Length of Chain 120".

OVERALL DIMENSIONS

w:	39"	39"
h:	19"	19"
d:	26.75"	31.5"

Part # Model #	240039 DGF-55 55 GAL. DRUM JNIT	270240 DGF-30A 30 GAL. DRUM ADAPTER	270402 FBA FIBER DRUM ADAPTER	240148 PJ	272403 VFDLT-1400
Capacity	Half Drum - 500 lbs Full Drum - 800 lbs	Half Drum - 500 lbs Full Drum - 800 lbs	Half Drum - 500 lbs Full Drum - 800 lbs	1,000 lbs	Half Drum - 750 lbs Full Drum - 1,400 lbs
Weight	159 lbs	24 lbs	3 lbs	44 lbs	214 lbs

Note: OSHA requires contacting the manufacturer of your fork truck for written approval for the use of any fork truck attachments.



Part# 272083 | .53 lbs. With flame arrestor. **FM APPROVED** for non-viscous liquids.



Part# 272080 | .53 lbs. No flame arrestor. **FM APPROVED** for viscous liquids only.

Zinc Die Cast Faucets

- Zinc die cast alloy.
- Easy-to-use self-closing design.
- Can be padlocked in closed position.
- .75" NPT connection.
- Viton gasket.



Heavy Duty 2" Brass Gate Valve

- Fast, self-closing PTFE blade.
- 2" NPSM connection designed to work in both a straight or tapered thread.
- 6.80 lbs.

Part# 272034 | **FM APPROVED** for use with viscous non-corrosive fluids heavier than 30 SAE.



Heavy Duty 304 Stainless Steel Faucet

- Adjustable shank designed to easily adjust to proper drain position after installing in drum.
- .75" NPT connection.
- PTFE gasket.
- 1.50 lbs.

Part# 272038 | Internal flame arrestor. **FM APPROVED** for use with oils (under 30 SAE) and non flammables, compatible with stainless steel.

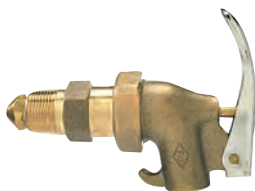

Part# 272037 | 1.40 lbs. Adjustable shank designed to easily adjust to proper drain position after installing in drum. Internal flame arrestor. **FM APPROVED** for use with oils (under 30 SAE) and non-corrosive flammables.

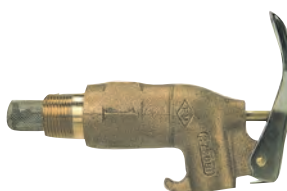

Part# 272081 | 1.43 lbs. Rigid shank design. External flame arrestor. **FM APPROVED** for use with oils (under 30 SAE) and non-corrosive flammables.

Heavy Duty Brass Faucets

- Easy-to-use self-closing design.
- .75" NPT connection.
- PTFE gasket.

Plastic Faucets



Part# 272176 - 2"

- 2" NPT polyethylene drum faucet produced from FDA approved material. Includes 3 EPDM sealing gaskets: thin, medium, thick. Good for viscous non-corrosive fluids.
- .83 lbs.



Part# 272179 with level gauge

- Deluxe 2" NPT polyethylene drum faucet. Produced from FDA approved material. Deluxe features:
 - Level gauge port
 - Pail hook
 - Lockable handle
 - 3 EPDM gaskets: thin, medium, thick.
- 1 lb.



Part# 272179 - 2"



Part# 272177 - .75"

- .75" Polyethylene Faucet for use with non-flammable, non-corrosive thin liquids not suitable for heavy oils.
- .10 lbs.

Wesco recommends that if a question arises, the user contact the supplier of chemicals to determine if these faucets are compatible with those chemicals. Wesco is unable to offer specific recommendations for chemical usage.



Part# 272030
For drums in horizontal (pouring) position. Manual vacuum relief by lifting and rotating valve stem.
FM APPROVED.

Drum Vent

- Automatically relieves pressure at 5 PSI.
- Maximum flow of 220 CFM at 20 PSI.
- Flame arrestor prevents sparks and flame from igniting drum contents.
- Fits 2" bung hole in steel and plastic drums.
- 1 lb.



Part# 272005 - 2.16 lbs.
Basic gauge with fitting.

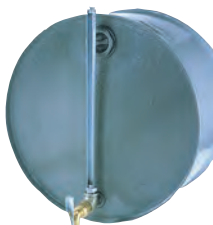

Part# 272006 - 4 lbs.
Basic gauge with fitting and 272080 faucet.

Part# 272041 - 5 lbs.
Basic gauge with fitting and 272083 faucet.

Part# 272115 -
Replacement glass for gauge.

Gauges

- Economical way to gauge drum contents.
- Heavy gauge glass and plated steel construction.
- Accepts standard .75" NPT faucet.
- Buna-N seals; .75" NPT connection, 22" height (with supplied fitting).



Part #272140
Model #DF

Drum Funnel with Lockable Cover

- Red polyethylene 4-quart funnel with 2" NPS fitting to screw into bung opening.
- 9.625" opening.
- Equipped with black polyethylene lockable cover and removable strainer screen.
- 1.1 lbs.



Vertical Polyethylene Pop-up Gauge

- Pops up to indicate drum is almost full.
- Fits standard 3/4" - 14 NPS bung holes.
- Part #272216, Model # PUG-5 - 5" long.
- Part #272217, Model # PUG-11 - 11" long.
- Closure cap.

Ground and Bond Wires

•A wide variety of designs for grounding and bonding applications.

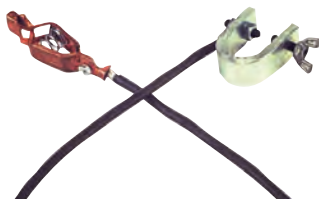

Part# 272032 - .64 lbs
Deluxe Ground Wire: For connection between drum and true ground. Three-foot-long heavy duty insulated wire rope with "C" clamp on one end and alligator clip on the other.



Part# 272031 - .53 lbs
All Purpose Bond Wire: For bonding drums to each other, to containers being filled, and to racks. Three-foot-long heavy duty wire rope with "C" clamp on one end and alligator clip on the other.



Part# 272033 - .37 lbs
Standard Bond Wire: For bonding drums to each other, to containers being filled, and to racks. Three-foot-long heavy duty wire rope with alligator clips on both ends.

OSHA requires that all drums and containers storing and receiving fluids with a FLASH POINT BELOW 140°F be grounded and bonded. Single drums must be grounded, with containers being dispensed into bonded to the drum. Multiple drums must be bonded to each other with one drum or the rack grounded. Wesco Ground and Bond wires allow meeting these important safety requirements.



Part# 272303
Vertical slide deheader. (6.2 lbs.)
Part# 272304 Replacement blade. (1 lb.)



Part# 272018
Most popular deheader. (7 lbs.)

Part# 272012
Replacement blade. (.73 lbs.)



Part# 440013 Model DDH-1.
Heavy duty deheader. (9 lbs.)

Part# 440014 Model DDH-P202
Replacement blade. (.60 lbs.)

Deheaders

- Open any size and gauge steel drum quickly and easily, allowing drum recycling without the risk of fire from cutting with a torch.
- Sharp-edged hardened steel replaceable blade.
- Comfortable plastic hand grip.



Part# 272017
(4 lbs.)
Handles bung patterns 1, 2, 3, & 4.

Universal Drum Plug Wrench

- Heavy duty cast iron construction.
- Opens most plugs and bung nuts, male & female, steel & plastic.
- Iron alloy will not chip or bend in normal use.
- Protects knuckles.

Bung Patterns

1	
2	
3	
4	
5	

Non-Sparking Drum Plug Wrenches

- Bronze alloy.
- Stronger than aluminum.
- Offset handle design reduces user stress and minimizes knuckle injury.



Part# 272016
(2 lbs.)
Our most popular wrench.
Handles bung patterns 1, 2, 3, & 5.



Part# 272178
(.53 lbs.)
Aluminum Non-Sparking Drum Wrench.
Handles bung patterns 1 & 3.



Part# 272086
(3 lbs.)
Deluxe model. Built-in 1.25" wrench for tightening faucets into drums. Handles bung patterns 1, 2, 3, & 5.

Part #	Description	Weight - lbs	Overall Width	Overall Height	Overall Length
272303	Vertical slide deheader	6.20	5.75"	5.875"	17.75"
272304	Replacement blade for Part# 272303	1.00	2.75"	2.75"	.1875" (THK)
272018	Manual drum deheader	7.00	6"	4.25"	20.68"
272012	Replacement blade for Part# 272018 deheader	.73	2.75"	2.50"	.1875" (THK)
440013	Zinc plated heavy duty deheader	9.00	6.375"	4.625"	23.625"
440014	Replacement blade for Part# 440013 deheader	.60	3.1875"	2.875"	.1875" (THK)
272017	Universal cast iron drum wrench	4.00	3.625"	3.50"	13.125"
272016	Standard non-sparking drum wrench	2.00	2.50"	3.25"	12"
272178	Non-sparking aluminum wrench	.53	2.25"	1.75"	10.25"
272086	Deluxe non-sparking drum wrench	3.00	3.625"	3.125"	11.50"



Part# 272212
Deluxe Combo (consists of #270021 Rotary Pump and #272211 Drip Pan) (18 lbs.)

Part# 270021
Cast Iron Rotary Drum Pump ONLY (12.5 lbs.)

Rotary Pump

- 47" 3 piece plated suction tube (assembled).
- Durable phenolic veins. Self-priming.
- Supplied with 48" PVC discharge tube.
- UPS shippable.
- Rugged cast iron construction.
- **ALWAYS USE A GROUND WIRE.**



Aluminum Pump only.

Part# 440017
Aluminum, non-sparking for medium viscosity petroleum-based products. Does not include drip pan. (17 lbs.)

Non-Sparking Rotary Pump

- Rugged aluminum construction.
- 47" 3 piece steel-plated suction tube (assembled).
- Durable phenolic veins.
- Self-priming.
- Supplied with 48" PVC discharge tube.
- UPS shippable.
- *Always use a ground wire.*



Part# 272210
(18 lbs.)



Part# 272211
Drip pan. (6 lbs.)

**Lever Pump/
Drip Pan**

- For installation on pumps with metal suction tube.
- Cast iron and steel construction.
- Hinged cover and bung/suction adapter.
- UPS shippable.
- **ALWAYS USE A GROUND WIRE.**



Part# 272397
(13 lbs.)

304 Stainless Steel Rotary Pump

- Made from corrosion resistant materials of construction.
- 304 stainless steel pump body.
- 304 stainless steel dispensing spout.
- 304 stainless steel 3 piece suction tube.
- PTFE vanes.
- UPS shippable.
- Compatible fluids: solvents, oils, mild corrosives.
- Min./ Max. temperature rating: 40° Fahrenheit / 140° Fahrenheit.
- 2" NPT Bung Adapter fits 15, 30 and 55 gallon drums.
- **ALWAYS USE A GROUND WIRE.**

Part #	Description	Weight - lbs	Overall Width	Overall Height	Overall Length
270021	Cast iron pump	12.50	9.4375"	56.25"	8.75"
272212	Deluxe combo with drip pan	18.00	9.4375"	56.25"	14"
440017	Non-sparking rotary pump	17.00	9.4375"	56.25"	9.50"
272210	Lever pump with drip pan	18.00	15.875"	60.343"	14"
272211	Drip pan	6.00	6.3125"	6.00"	14"
272397	304 stainless steel rotary pump	13.00	9.125"	53.125"	8.75"

Application Information (For Rotary and Lever Pumps): WESCO iron drum pumps have wetted parts fabricated from cast iron, steel, phenolic (270021 & 272212 only), and neoprene (272210 only) materials. These pumps were designed primarily for the transfer of fuel oil products. It should be noted that these pumps can only be used for chemicals which are compatible with cast iron, steel, neoprene and phenolic.

We recommend that if a question arises, the user contact the supplier of chemicals to determine if these pumps are compatible with those chemicals. WESCO is unable to offer specific recommendations for chemical usage.

Wesco Exclusive: Ribbed Cross Straps for Additional Strength



- Industrial strength heavy duty 3/4" structural steel frame construction.
- Ribbed cross braces for extra strength.
- All joints double welded.
- 8" deep by 14" wide nose is 7 gauge thick plate with machined beveled edge and radiused corners for safety.
- Zinc plated Auto-Loc® axles assure smooth wheel rotation.
- All frames handle 8" or 10" wheels.
- Order by part # or model #: Part # 210009 or Model # 126-R



126D-Z8

Series 126D

- Single "D" shaped handle allows multiple hand positions for one hand control.
- Ideal for boxes, kegs, and packages.
- Three horizontal cross straps and full height vertical center strap provide support for small packages.

OVERALL DIMENSIONS

w: 22.5"
h: 46"
d: 16.5" w/8" wheel | 18.5" w/10" wheel



126-Z

Series 126

- Single pin handle curved back design allows one hand control.
- Ideal for boxes, kegs, and packages.
- Three horizontal cross straps and full height vertical center strap offer support for small packages.

OVERALL DIMENSIONS

w: 22.5"
h: 46"
d: 16.5" w/8" wheel | 18.5" w/10" wheel



136-Z

Series 136

- Two handle tapered body design.
- Three heavy duty horizontal cross straps for added strength.
- Full height center strap provides support for small packages.

OVERALL DIMENSIONS

w: 22.5"
h: 46"
d: 16.5" w/8" wheel | 18.5" w/10" wheel

Part # Model #	210009 126-R	210010 126-Z8	210011 126-Z	210380 126-Z2	210012 126-P	210370 126-PE	210016 126D-R	210017 126D-Z8	210018 126D-Z	210381 126D-Z2	210019 126D-P	210371 126D-PE	210024 136-R	210025 136-Z8	210026 136-Z	210382 136-Z2	210027 136-P	210372 136-PE
Capacity	800 lbs	600 lbs	700 lbs	800 lbs	700 lbs	700 lbs	800 lbs	600 lbs	700 lbs	800 lbs	700 lbs	700 lbs	800 lbs	600 lbs	700 lbs	800 lbs	700 lbs	700 lbs
Wheel Type	R	Z8	Z	Z2	P	PE	R	Z8	Z	Z2	P	PE	R	Z8	Z	Z2	P	PE
Weight	32 lbs	38 lbs	40 lbs	40 lbs	37 lbs	34 lbs	33 lbs	39 lbs	41 lbs	41 lbs	38 lbs	35 lbs	33 lbs	39 lbs	41 lbs	40 lbs	39 lbs	34 lbs

100 Series Industrial Hand Truck Options

Nose Extension

- 24" long, 10.5" wide.
- Steel construction.



Stairclimber

- Continuous belt.
- Replaceable parts.
- Only available on 10" wheeled models.
- Factory installed only.



Part # Model #	210099 FN-24K	054201 FN-24F	270412 CBSCF
Description	24" Nose Extension - Field Installation	24" Nose Extension - Factory Installed	Continuous belt stairclimber Must be Factory Installed
Weight	4 lbs	4 lbs	7 lbs

FACTORY INSTALLED add part # or model # to end of industrial hand truck part or model #.

EXAMPLE: 156R with 24" nose extension Part # 210044,054201 or Model #156-R-FN-24F.

Additional choices not listed above.

R	Z8	Z	Z2	P	PE	BC-8	BC-10	CF (Flat Free)
Aluminum 8" x 1.625" Moldon Rubber	Poly Offset 8" x 2" Solid Rubber	Steel Offset 10" x 2.75" Semi-Pneumatic	Poly Offset 10" x 2.75" Solid Rubber	Steel Offset 10" x 3.5" Pneumatic	Steel Offset 10" x 3.5" Pneumatic	Poly Hub 8" x 2.165" Balloon Cushion	Poly Hub 10" x 2.165" Balloon Cushion	Steel Offset 10" x 3" Microcellular
108545	150697	150589	150698	050602	151551	150229	150228	053446



Wesco Exclusive: Ribbed Cross Straps for Additional Strength



146-R

Series 146

- Two handle extra high back curved design.
- Ideal for high loads.
- Four horizontal cross straps and vertical center strap provide support for small packages.

OVERALL DIMENSIONS

w: 22.5"
h: 51"
d: 16.5" w/8" wheel 18.5" w/10" wheel

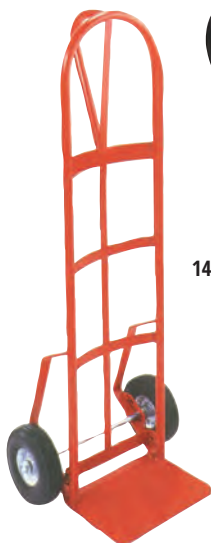

146D-Z8

Series 146D

- Single "D" shaped handle combined with high back curved design.
- Easier one hand control of stacked goods.
- Four horizontal cross straps and vertical center strap provide support for small packages.

OVERALL DIMENSIONS

w: 22.5"
h: 51"
d: 16.5" w/8" wheel 18.5" w/10" wheel



304 Stainless Steel

Series 626D-SS

- Stainless steel model 7.5" deep x 13.75" wide, 7 gauge beveled nose plate with radiused corners for safety.
- For complete details, see Page 8.

Part #	210362
Model #	626D-SS
Capacity	500 lbs
Weight	24 lbs



156-Z Steel

Series 156

- Swept back continuous handle with curved back design.
- Versatile frame that allows one or two hand control.
- Four horizontal cross straps and vertical center strap provide support for small packages.
- Stainless model has 8" x 2" polyurethane tread on polypropylene hub, non-marking wheels with 440 stainless sealed 3/4" precision ball bearing.

OVERALL DIMENSIONS

w: 22.5"
h: 48"
d: 16.5" w/8" wheel 18.5" w/10" wheel



156-PP8-SS 304 Stainless Steel

Part # Model #	210032 146-R	210033 146-Z8	210034 146-Z	210383 146-Z2	210035 146-P	210373 146-PE	210038 146D-R	270056 146D-Z8	210039 146D-Z	210384 146D-Z2	210040 146D-P	210374 146D-PE	210044 156-R	210045 156-Z8	210046 156-Z	210385 156-Z2	210047 156-P	210375 156-PE	210351 156-PP8-SS	
Capacity	800 lbs	600 lbs	700 lbs	800 lbs	700 lbs	700 lbs	800 lbs	600 lbs	700 lbs	800 lbs	700 lbs	700 lbs	800 lbs	600 lbs	700 lbs	800 lbs	700 lbs	700 lbs	700 lbs	600 lbs
Wheel Type	R	Z8	Z	Z2	P	PE	R	Z8	Z	Z2	P	PE	R	Z8	Z	Z2	P	PE	PE	PP8
Weight	34 lbs	40 lbs	42 lbs	42 lbs	39 lbs	36 lbs	35 lbs	41 lbs	43 lbs	42 lbs	41 lbs	36 lbs	34 lbs	37 lbs	39 lbs	40 lbs	36 lbs	34 lbs	34 lbs	33 lbs

Additional choices not listed above.

PP8	R	Z8	Z	Z2	P	PE	BC-8	BC-10	CF (Flat Free)
8" x 2" Polyurethane Tread Polypropylene Hub 3/4" Ball Bearing	Aluminum 8" x 1.625" Moldon Rubber	Poly Offset 8" x 2" Solid Rubber	Steel Offset 10" x 2.75" Semi-Pneumatic	Poly Offset 10" x 2.75" Solid Rubber	Steel Offset 10" x 3.5" Pneumatic	Steel Offset 10" x 3.5" Pneumatic	Poly Hub 8" x 2.165" Balloon Cushion	Poly Hub 10" x 2.165" Balloon Cushion	Steel Offset 10" x 3" Microcellular
053733	108545	150697	150589	150698	050602	151551	150229	150228	053446

ERGONOMIC TOUCH-N-TILT® & DRUM HAND TRUCKS



Structural steel frame construction. | Ribbed x-braces for extra strength. | All joints double welded.



TNT56-Z

Push a pedal and your load feels lighter – 66% lighter

The Touch-N-Tilt® Ergonomic Hand Truck

Press the pedal and the effort to break over the load is reduced by as much as 66%. Minimizes physical demands of the workplace.



Touch-N-Tilt®

- Simple and affordable.
- Up to 700 lbs. capacity.
- Available with 8" or 10" wheels.
- Same strong frames used on Wesco 100 series industrial truck.
- Noseplate 7 GA. 8" D x 14" W.

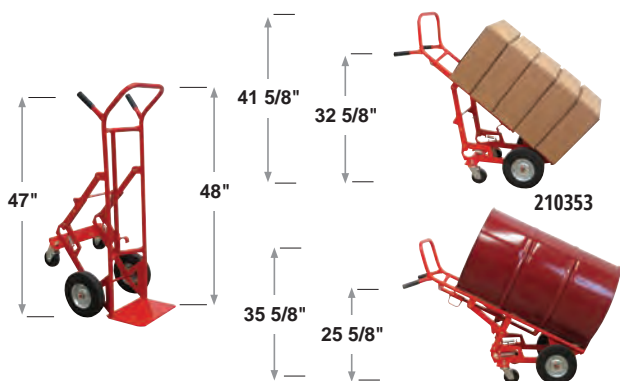

4-Wheel Drum Cart

- Two position, 4-wheel transport design to handle drums and standard loads.
- Position I:** Easily handles and maneuvers standard loads as a 4-wheel transport.
- Position II:** With the chime hook engaged and a press of the foot pedal, the frame tilts a 30 or 55 gallon steel drum to a balanced position to maintain 4-wheel contact even with half empty bottom heavy drums.
- Two 3.5" x 1.5" polyolefin swivel casters for easy maneuverability in narrow spaces.
- Chime hook to engage 30 & 55 gallon steel drums.
- 7.8" D x 14" W beveled edge noseplate.
- Curved frame holds 5-gallon pails and kegs.



156DH-Z

156DH-PP8-SS
304 STAINLESS STEEL



156DH Drum/Hand Truck

- Utility of a hand truck & drum truck.
- Chime hook works with 55 and 30 gallon steel drums.
- Curved frame holds 5-gallon pails and kegs.
- With noseplate resting flat on floor, 18" to center of lowered chime hook.
- Noseplate 7.8" D x 14" W.
- Stainless model has 8" x 2" polyurethane tread on polypropylene hub, non-marking wheels with 440 stainless sealed 3/4" precision ball bearing.

	OVERALL DIMENSIONS			OVERALL DIMENSIONS			OVERALL DIMENSIONS		
	w: 20"	22"	22"	w: 20.5"	20.5"	20.5"	w: 19.25"	19.25"	19.25"
	h: 50"	50"	50"	h: 48"	48"	48"	h: 26.25"	48.5"	48.5"
	d: 19.75"	19.75"	19.75"	d: 18.5"	17.5"	18.5"	d: 48"	25"	25"
							304 Stainless		
Part #	210546	210549	210547	210340	210349	210266	210352	210353	210354
Model #	TNT56-Z	TNT56-Z2	TNT56-P	156DH-Z	156DH-HB	156DH-P	156DH-PP8-SS	4WDC-ZC	4WDC-HBC
Capacity	600 lbs	700 lbs	600 lbs	700 lbs	800 lbs	700 lbs	600 lbs	800 lbs	900 lbs
Wheel Type	Z	Z2	P	Z	HB	P	8" Polyurethane	10" / Z	8" / HB
Weight	41.5 lbs	42 lbs	38.5 lbs	39 lbs	42.5 lbs	39 lbs	33.5 lbs	66 lbs	66 lbs





Oversized 12" pneumatic tire for easy mobility on rough terrain.

ST2-P12



Heavy Duty Shovel Nose Trucks

- Five year weld guarantee.
- 13" deep x 17.5" x .25" thick tapered nose plate.
- 1" heavy duty structural steel frame.
- Easy grip continuous handle frame design.
- 3/4" axle.
- Wheel guards.
- 2 wheel types - 8" & 12".



Steel Reinforced on underside of nose plate.

146RN-HB



186-ZC

Swivel caster



Heavy Duty 186 Series

- Rear caster design allows small diameter turns in tight areas.
- Combination two handle and utility bar handle design.
- Distribution of load over 4 wheels improves load control.
- All wheels have ball bearings.
- Wheel guards.



Heavy Duty Hand Truck

- 8" x 2" cast iron center moldon rubber wheels.
- 7.25" x 14" steel reinforced nose plate.
- .75 inch axle.
- Five handle choices.

OVERALL DIMENSIONS

w: 19.625"
h: 51"
d: 17.5"

	OVERALL DIMENSIONS		OVERALL DIMENSIONS		NOSE PLATE				
	w:	h:	w:	h:	126 HANDLE	126D HANDLE	136 HANDLE	146 HANDLE	156 HANDLE
	20.5"	53"	20.5"	48"					
	22"	25.5"	25"	25"	d: 8"				
Part #	210064	210066	210125	210263	210264	210134	210135	210265	
Model #	ST2-HB	ST2-P12	186-ZC	126RN-HB	126DRN-HB	136RN-HB	146RN-HB	156RN-HB	
Capacity	900 lbs	800 lbs	800 lbs	800 lbs	800 lbs	800 lbs	800 lbs	800 lbs	800 lbs
Wheel:									
Front	HB	P-12"	Z	HB	HB	HB	HB	HB	HB
Rear	N/A	N/A	4" x 1.25" Poly Swivel Caster	N/A	N/A	N/A	N/A	N/A	N/A
Weight	69 lbs	69 lbs	53 lbs	39 lbs	40 lbs	41.5 lbs	42 lbs	38 lbs	

- 5 year weld guarantee.
- All joints double welded.
- Structural steel frame construction.
- Ribbed x-braces for added strength.



HEAVY DUTY WAREHOUSE AND CONVERTIBLE HAND TRUCKS



TM-BT



TM4W-HB



Heavy Duty Warehouse Trucks

- Five year weld guarantee.
- Large 10" deep x 16.5" wide x .25" thick tapered nose plate.
- 1" heavy duty structural steel frame.
- Wheel guards standard.
- Dual handle design.
- Kick out four wheel model – TM4W or standard two wheel model.
- 3.5" moldon rubber swivel casters on four wheel kick out trucks.
- New longer 14 ft. belt length on TM4W models.



156-S23-Z2



2-in-1 Deluxe Industrial Steel Hand Trucks*

- Five year weld guarantee.
- Converts easily between 2 and 4 wheel truck.
- Handle locks in horizontal and vertical positions.
- Two lengthwise straps and two cross braces prevent package fall-through.
- Caster: 3.5" TPR gray, non-marking, round tread, thermoplastic rubber wheel resists almost every type of floor debris including metal shavings chips, sand and gravel.
- Heavy duty 3/4" Dia. structural steel frame. All joints double welded, both sides.
- Bed size: 14" x 44.5".
- Noseplate 14"W x 8"D.
- Less energy required to start moving load and keep it moving.
- Smooth, quiet ride of a soft-tread wheel, durable as a hard-tread wheel.

OVERALL DIMENSIONS

w: 21"	21"	21"
h: 50.5"	50.5"	50.5"
d: 22.5"	23.5"	24"

OVERALL DIMENSIONS

w: 20.5"	20.5"	20.5"
h: 37.25"	4-Wheel / 50.25"	2 Wheel
d: 22.5"	22"	22"

OVERALL DIMENSIONS

w: 20.5"
h: 53"
d: 19"

Part # Model #	210055 TM-HB	210056 TM-PB	210239 TM-BT	210060 TM4W-HB	210061 TM4W-PB	210062 TM4W-BT	210138 156-S23-Z	210140 156-S23-Z2	210139 156-S23-P
Capacity	900 lbs	700 lbs	1,000 lbs	900 lbs	700 lbs	1,000 lbs bs	2 wheel - 700 lbs 4 wheel - 1,000 lbs	2 wheel - 800 lbs 4 wheel - 1,000 lbs	2 wheel - 700 lbs 4 wheel - 1,000 lbs
Wheel Type	HB	PB	BT	HB	PB	BT	Z	Z2	P
Caster	N/A	N/A	N/A	3.5"	3.5"	3.5"	3.5"	3.5"	3.5"
Weight	54 lbs	49 lbs	75 lbs	78 lbs	75 lbs	98 lbs	61 lbs	58 lbs	55 lbs

HB	PB	BT	PE	SR	Z	Z2	P
Cast Iron 8" x 2" Moldon Rubber	Steel Offset 10" x 3.5" Pneumatic	Cast Iron 10" x 2.5" Moldon Rubber	Steel Offset 10" x 3.5" Pneumatic	Poly Offset 10" x 2.5" Solid Rubber	Steel Offset 10" x 2.75" Semi-Pneumatic	Poly Offset 10" x 2.75" Solid Rubber	Steel Offset 10" x 3.5" Pneumatic
150120	108478	150596	151551	108479	150589	150698	050602

• Economically priced.

- Zinc plated Auto-Loc® axles assure smooth wheel rotation.
- All frames can accommodate an 8" or 10" wheel.
- 7" deep x 14" wide 7 gauge beveled nose plate with radiused corners for safety.
- 1" OD x 14 gauge wall tubular frame.

• Order by part # or model #.

Example:
Part #210461 **OR** Model # 626-Q

Series 626

- Pin handle with curved back design.
- Welded frame construction.
- 1" O.D. tube.



626-Z8

OVERALL DIMENSIONS

w: 21.75"
h: 45.5"
d: 17"

Series 626D

- Single loop handle with curved back design.
- Welded frame construction.
- 1" O.D. tube.



626D-R

OVERALL DIMENSIONS

w: 21.75"
h: 50.5"
d: 17"

Series 636

- Dual handle curved back design.
- Welded frame construction.
- 1" O.D. tube.



636-Z8

OVERALL DIMENSIONS

w: 21.75"
h: 48.5"
d: 17"

Part # Model #	210466 626-R	210330 626-Z8	210361 626-Z2	210456 626-P	210356 626-PE	210467 626D-R	210331 626D-Z8	210362 626D-Z2	210457 626D-P	210357 626D-PE	210468 636-R	210332 636-Z8	210363 636-Z2	210458 636-P	210358 636-PE
Capacity	600 lbs	500 lbs	600 lbs	600 lbs	600 lbs	600 lbs	500 lbs	600 lbs	600 lbs	600 lbs	600 lbs	500 lbs	600 lbs	600 lbs	600 lbs
Wheel Type	R	Z8	Z2	P	PE	R	Z8	Z2	P	PE	R	Z8	Z2	P	PE
Weight	25.5 lbs	25.5 lbs	31 lbs	27.5 lbs	26 lbs	27 lbs	27 lbs	36 lbs	29 lbs	27.5 lbs	26 lbs	26 lbs	31.5 lbs	28 lbs	26.5 lbs

Series 646

- Dual pin handle with curved back design.
- Welded frame construction.
- 1" O.D. tube.



646

OVERALL DIMENSIONS

w: 21.75"
h: 50.5"
d: 20"

Series 656

- Continuous handle with curved back design.
- Welded frame construction.
- 1" O.D. tube.



656

OVERALL DIMENSIONS

w: 21.75"
h: 49"
d: 19"

Folding Nose Extension Option

- To order field installation simply note part # or model # on P.O.
- To order factory installed option (626D-R with 24" nose extension) add option part # or model to the end of the truck part # or model.



Example:

Part # 210467,054218 or
Model + Option 626D-R-FNG-24F

Part # Model #	210469 646-R	210333 646-Z8	210364 646-Z2	210459 646-P	210359 646-PE	210470 656-R	210334 656-Z8	210365 656-Z2	210460 656-P	210360 656-PE	210249 FNG-24K	054218 FNG-24F
Capacity	600 lbs	500 lbs	600 lbs	600 lbs	600 lbs	600 lbs	500 lbs	600 lbs	600 lbs	600 lbs	Capacity rating same as truck.	
Wheel Type	R	Z8	Z2	P	PE	R	Z8	Z2	P	PE	Field Installation	Factory Installed
Weight	27 lbs	27 lbs	32.5 lbs	29 lbs	27.5 lbs	27.5 lbs	27.5 lbs	33 lbs	29.5 lbs	28 lbs	4 lbs	4 lbs

Additional choices not listed above.

R	Z8	Z2	P	PE	BC-8	BC-10	CF (Flat Free)	Z
Aluminium 8" x 1.625" Moldon Rubber	Poly Offset 8" x 2" Solid Rubber	Poly Offset 10" x 2.75" Solid Rubber	Steel Offset 10" x 3.5" Pneumatic	Steel Offset 10" x 3.5" Pneumatic	Poly Hub 8" x 2.165" Balloon Cushion	Poly Hub 10" x 2.165" Balloon Cushion	Steel Offset 10" x 3" Microcellular	Steel Offset 10" x 2.75" Semi-Pneumatic
108545	150697	150698	050602	151551	150229	150228	053446	150589



Curb Ramp

Lightweight, portable ramp allows for easy movement up and down curbs. **600 lb capacity.**

OVERALL DIMENSIONS

w: 21.5"
h: 6"
d: 23.5"

Part #	150800
Description	Yellow generic
Weight	7 lbs



210127



210215

SR Economy Hand Truck

- 7.5" x 14" nose plate.
- 16 gauge frame.
- Two Wheel Choices:
10" Pneumatic and
10" Solid Rubber Wheels.

OVERALL DIMENSIONS

w: 21.5"	21.5"
h: 51"	51"
d: 19"	19"



656-21-Z



Greenline Economical 2-in-1

- Converts easily between 2 and 4 wheel truck.
- Double welded tubular construction.
- Lengthwise strap and cross braces prevent package fall-through.
- Solid rubber swivel casters.
- Bed size 13" x 36".
- 14" W x 7" D noseplate.

OVERALL DIMENSIONS

w: 20"	20"	20"	20"
h: 48"	48"	48"	48"
d: 15"	16"	16"	16"



E-CON

Greenline E-Con 2-in-1 Truck

- Heavy duty tubular steel construction.
- 18"w. x 8.5"d. noseplate.
- Lever activated position conversion.
- Wheel guards.
- Bed size - 13.75" x 48".
- Wheel: 10" x 2.75" solid rubber.
- Swivel caster: 5" x 1.375" moldon polyurethane.

OVERALL DIMENSIONS

w: 19.5"
h: 58"
d: 18"

Part # Model #	210127 SR Economy-PE	210215 SR Economy - SR	210321 656-21-Z8	210324 656-21-Z	210326 656-21-Z2	210325 656-21PE	210639 E-CON
Capacity 2 wheel 4 wheel	500 lbs	500 lbs	500 lbs 600 lbs	500 lbs 600 lbs	500 lbs 600 lbs	500 lbs 600 lbs	700 lbs 800 lbs
Caster	N/A	N/A	5"	5"	5"	5"	5"
Wheel Type	10" Pneumatic	10" Solid Rubber	Z8	Z	Z2	PE	10" x 2.75" Solid Rubber
Weight	26 lbs	28 lbs	7 lbs	46 lbs	44 lbs	38 lbs	74 lbs

Z8	Z	Z2	PE	P
Poly Offset 8" x 2" Solid Rubber	Steel Offset 10" x 2.75" Semi-Pneumatic	Poly Offset 10" x 2.75" Solid Rubber	Steel Offset 10" x 3.5" Pneumatic	Steel Offset 10" x 3.5" Pneumatic
150697	150589	150698	151551	050602



***For Aluminum Convertible Trucks,
see pages 34-36.**



Hydraulic Cylinder Lift

- 1-year warranty, parts only.
- WESCO manufactured hydraulic Pedalift Jack, over 35 years of proven quality.
- Easily lifts and transports gas cylinders.
- Swivel casters make maneuvering in tight places easier.
- **Two models:**
 - Foot operated hydraulic pump.
 - Manual winch with auto-brake feature.
- Maximum cylinder diameter 9.5".
- Platform size: 12" x 20".



Professional Series Cylinder Trucks

- Safety chain helps secure load.
- Easy conversion between all 3 modes using spring-loaded position lock mechanism.
- 8" moldon rubber wheels, 3" swivel casters.
- Holds cylinders up to 9 1/4" in. diameter.
- Noseplate 9" W x 7 1/4" D - single cylinder.
- Noseplate 16 7/8" W x 7 1/4" D - double cylinder.



Hydraulic Large Liquid Gas Cylinder Cart

- 1-year warranty, parts only.
- WESCO made hydraulic pump - over 35 years of proven quality.
- Easy transport of large liquid 20" gas cylinders.
- Foot operated hydraulic pump.
- 10" x 2.5" polyurethane wheels.
- 8" polyurethane non-marking swivel caster with swivel locks.
- Ratchet tightening belt to secure cylinder.
- Lifting hook engages cylinder without hand contact - permits hands-free lifting.
- #240250 - without brake.
- #240251 - with brake.

OVERALL DIMENSIONS	
w:	20"
h:	54"
d:	29.25"

4-WHEEL OVERALL DIMENSION	
w:	19" 29"
h:	36.5" 37"
d:	32" 32"

2-WHEEL OVERALL DIMENSION	
w:	19" 29"
h:	41.75" 42.25"
d:	17.5" 18.5"

STORAGE OVERALL DIMENSION	
w:	19" 29"
h:	41.75" 42.25"
d:	26" 26"

OVERALL DIMENSIONS	
w:	29.75"
h:	66.25"
d:	44.75"

Part #	260161	260163	210123	210124	240250	240251
Model #	LLHPB	LLWPB	CC-1	CC-2	HLCC	HLCC-B
Capacity	300 lbs	300 lbs	250 lbs	500 lbs	1,000 lbs	1,000 lbs
Wheel Type	5"	5"	8" Moldon Rubber	8" Moldon Rubber	10" x 2.5" Polyurethane	With Brake 10" x 2.5" Polyurethane
Caster	5" swivel	5" swivel	3"	3"	8" x 2" Swivel	8" x 2" Swivel
Lift Height	40" / Hydraulic	40" / Winch	N/A	N/A	71"	71"
Lowered Height	25"	.25"	N/A	N/A	54"	54"
Weight	165 lbs	152 lbs	40 lbs	50 lbs	130 lbs	140 lbs

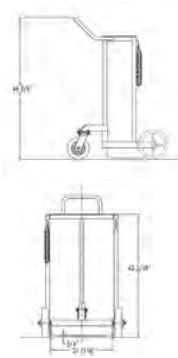

Large Liquid Gas Cylinder Cart

- Easy transport of large liquid 20" gas cylinders.
- Low profile design eases cylinder loading.
- Upright design takes up less floor space than traditional lay-back design and provides greater maneuverability in confined space.
- 8" polyurethane-tread, non-marking crowned swivel caster with rolling and swivel lock.
- 10" polyurethane-tread main wheels.
- Heavy duty structural pipe and steel pipe frame.
- Quick-connecting chain helps secure load.

Variable Speed Power Drive Provides Unmatched Mobility and Maneuverability in a Compact Design



Large Liquid Gas Cylinder Cart with Power Drive

- 180 degree hinged design allows precision steering in confined spaces.
- Maximum speed with full charge 1.7 mph (2.5 fps) (No Load).
- Speed control is adjustable from 0 to 1.7 mph.
- Automatic Dead Man Brake engages if handle is released.
- Automatic emergency safety switch instantly reverses direction if control comes in contact with the operator or an obstacle.
- Low profile design for ease of cylinder loading.
- High Strength Structural Tube Frame for Durability.
- Large 10" x 2.5" Polyurethane Front Wheels for smooth operation.
- Quick-connect Ratchet Strap to secure cylinder.

OVERALL DIMENSIONS

w: 30"
h: 48.625"
d: 31"

OVERALL DIMENSIONS

w: 30"
h: 49"
d: 40"

Part # Model #	210131 LCC	210131-PD LCC-PD
Capacity	1,000 lbs	1,000 lbs
Wheel Type	10" x 2.5" Polyurethane	10" x 2.5" Polyurethane
Caster	8" x 2" Swivel	8" x 2" Swivel
Lift Height	N/A	N/A
Lowered Height	N/A	N/A
Weight	90 lbs	196 lbs

10" x 2.5"
Polyurethane
Tread Poly-
propylene Hub



053730



*Hydraulic Cylinder Lift Truck—
see page 61.*



COBRA - LITE FEATURES

- All aluminum construction.
- Heavy duty cast 7.5" by 14" or 7.5" by 18" wide nose plate options.
- Quality light weight truck at an economical price.
- Ships KD and boxed or as components (see page 34/35).
- All 2" wide cross braces for additional strength. Great for advertising label.
- Assembly option available. Add "-A" to Part # below. | Example: 220566-A.



410-T14-R3

410 Series.

- Continuous handle.
- 49" overall height.
- Most popular model.
- Available with vinyl dipped handle.



450-T14-R3

450 Series.

- Twin handle style with vinyl grip.
- 49" overall height.

OVERALL DIMENSIONS

w: 18"
h: 49"
d: 20"

T14" Nose Part # Model #	220562 410-T14-BC10	220332 410-T14-R3	220321 410-T14-Z	220370 410-T14-Z2	220322 410-T14-P	220375 410-T14-PE	220564 420-T14-BC10	220333 420-T14-R3	220324 420-T14-Z	220371 420-T14-Z2	220325 420-T14-P	220376 420-T14-PE
Capacity	560 lbs	600 lbs	600 lbs	600 lbs	600 lbs	600 lbs	560 lbs	600 lbs	600 lbs	600 lbs	600 lbs	600 lbs
Wheel Type	BC-10	R3	Z	Z2	P	PE	BC-10	R3	Z	Z2	P	PE
Weight	23 lbs	23 lbs	27.5 lbs	31 lbs	22.5 lbs	21 lbs	23 lbs	19.5 lbs	27.5 lbs	26 lbs	22.5 lbs	21 lbs
T18" Nose Part # Model #	220563 410-T18-BC10	220392 410-T18-R3	220381 410-T18-Z	220396 410-T18-Z2	220382 410-T18-P	220365 410-T18-PE	220565 420-T18-BC10	220393 420-T18-R3	220384 420-T18-Z	220397 420-T18-Z2	220385 420-T18-P	220366 420-T18-PE
Capacity	560 lbs	600 lbs	600 lbs	600 lbs	600 lbs	600 lbs	560 lbs	600 lbs	600 lbs	600 lbs	600 lbs	600 lbs
Wheel Type	BC-10	R3	Z	Z2	P	PE	BC-10	R3	Z	Z2	P	PE
Weight	23 lbs	20.5 lbs	28.5 lbs	27 lbs	23.5 lbs	22 lbs	23 lbs	20.5 lbs	28.5 lbs	27 lbs	23.5 lbs	22 lbs



420-T18-P

420 Series.

- High back pin handle.
- Comfortable.



470-T14-BC10

470 Series.

- High back loop handle.
- 52" overall height.

OVERALL DIMENSIONS

w: 18"
h: 58"
d: 21"

T14" Nose Part # Model #	220566 450-T14-BC10	220334 450-T14-R3	220327 450-T14-Z	220372 450-T14-Z2	220328 450-T14-P	220377 450-T14-PE	220568 470-T14-BC10	220335 470-T14-R3	220330 470-T14-Z	220373 470-T14-Z2	220331 470-T14-P	220378 470-T14-PE
Capacity	560 lbs	600 lbs	600 lbs	600 lbs	600 lbs	600 lbs	560 lbs	600 lbs	600 lbs	600 lbs	600 lbs	600 lbs
Wheel Type	BC-10	R3	Z	Z2	P	PE	BC-10	R3	Z	Z2	P	PE
Weight	23 lbs	20 lbs	28 lbs	26.5 lbs	23 lbs	21.5 lbs	23 lbs	20 lbs	28 lbs	27 lbs	23 lbs	21.5 lbs
T18" Nose Part # Model #	220567 450-T18-BC10	220394 450-T18-R3	220387 450-T18-Z	220398 450-T18-Z2	220388 450-T18-P	220367 450-T18-PE	220569 470-T18-BC10	220395 470-T18-R3	220390 470-T18-Z	220399 470-T18-Z2	220391 470-T18-P	220368 470-T18-PE
Capacity	560 lbs	600 lbs	600 lbs	600 lbs	600 lbs	600 lbs	560 lbs	600 lbs	600 lbs	600 lbs	600 lbs	600 lbs
Wheel Type	BC-10	R3	Z	Z2	P	PE	BC-10	R3	Z	Z2	P	PE
Weight	23 lbs	21 lbs	29 lbs	27.5 lbs	24 lbs	22.5 lbs	23 lbs	21 lbs	29 lbs	27.5 lbs	24 lbs	22.5 lbs



BC
10" x 2.165"
Poly Offset Hub
Balloon Cushion
150228



BC
10" x 2.165"
Poly Offset Hub
Balloon Cushion
150228



BC
10" x 2.165"
Poly Offset Hub
Balloon Cushion
150228



BC
10" x 2.165"
Poly Offset Hub
Balloon Cushion
150228



BC
10" x 2.165"
Poly Offset Hub
Balloon Cushion
150228

- When ordering by part # add option part # to truck part #.
Example: 220332,220351
- When ordering by model #, add option model # to truck model #.
Example: 410-T14-R3-S3K.



Cobra-Lite Folding Nose for Cast and Extruded Noseplates



Cobra-Lite Stairglide Options



Cobra-Lite Stairclimber Options



Steel w/Wearstrip



* With continuous rolling belt (8" wheel only)

Part # Model #	Deluxe Cast Aluminum Stairglides								Stairclimbing Attachments			
	Factory Installed		Kit for Field Installation		Factory Installed		Kit for Field Installation		Factory Installed		Kit for Field Installation	
	20" long	30" long	20" long	30" long	Pair without wearstrips	Pair with wearstrips	Pair without wearstrips	Pair with wearstrips	Steel pair with wearstrips	Cast aluminum pair*	Steel pair with wearstrips	Cast aluminum pair*
CAST NOSE PRODUCTS												
054223 F2F	054225 F3F	220346 F2K	220343 F3K	054211 S2F	054213 S3F	220349 S2K	220351 S3K	054236 S4F	054237 S5F	220340 S4K	220339 S5K	
EXTRUDED NOSE PRODUCTS												
054202 F2EF	054203 F3EF	220082 F2E	220083 E3E	054211 S2F	054213 S3F	220349 S2K	220351 S3K	054236 S4F	054237 S5F	220340 S4K	220339 S5K	



Top Extensions for 410 & 450 Models

Installed Height of Extension	Factory Installed				Kit for Field Installation			
	44" high	52" high	60" high	68" high	44" high	52" high	60" high	68" high
Part # Model #	050144 44UF	054206 52UF	054207 60UF	054209 68UF	220347 44UK	220080 52UK	220081 60UK	220094 68UK

HERE'S HOW TO DESIGN YOUR TRUCK:

- Choose from these Components: Frame, Handle, Noseplate and Wheel.
- Then, choose your Options.
- When ordering by model #, add Option Model # to truck model #.
- **Example:** 41+0+T18+R3+F3+S4K=410-T18-R3-F3-S4K



1

CHOOSE YOUR FRAME.



2

CHOOSE A HANDLE.



41 - Continuous Handle
151512
Fits straight and curved frames.
Overall truck height will be 49"

42 - Pin Handle
151511
Fits straight and curved frames.
Overall truck height will be 52"



45 - Twin Handle w/brace
220119
Fits straight and curved frames.
Overall truck height will be 49"

46 - Flat Top Super D Handle
052512
Cannot be used with curved frame (5).
Overall truck height will be 60.5"



47 - Loop Handle
151510
Cannot be used with curved frame(5).
Overall truck height will be 52"



52 - Round Top Deep D Handle
154547
Cannot be used with curved frame (5).
Overall truck height will be 60"

3 CHOOSE A NOSEPLATE.



**ALUMINUM
T18 (cast)**
18" W x 7.5" D
151533



**ALUMINUM
E918 (extruded)**
18" W x 9" D
220461



**ALUMINUM
E14 (extruded)**
14" W x 7.625" D
220287



**ALUMINUM
E16 (extruded)**
16" W x 12" D
220286



**ALUMINUM
E18 (extruded)**
18" W x 7.625" D
220285

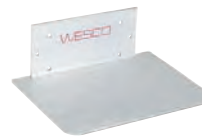

**ALUMINUM
EC16 (extruded)**
Recessed Heel 16" W x 12" D
220506
For Curved Frame Only

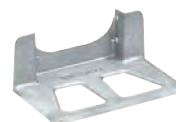

**ALUMINUM
T14 (cast)**
14" W x 7.5" D
151521

4 CHOOSE A WHEEL.



**BC-10
Poly Hub**
10" x 2.165"
Balloon Cushion
270274



**CF (Flat Free)
Steel Offset Hub**
10" x 3"
Microcellular Polyurethane. Will not go flat
220348



**P
Steel Offset Hub**
10" x 3.5"
Pneumatic Tire
054045



**PE
Steel Offset Hub**
10" x 3.5"
Pneumatic Tire
054231



**PWT
Steel Offset Hub**
10" x 3.625"
Pneumatic
Wide Tread Tire
220319



**Z
Steel Offset Hub**
10" x 2.75"
Semi-Pneumatic
Tire
054047



**Z2
Poly Offset Hub**
10" x 2.75"
Solid Rubber Tire
054230



**BC-8
Poly Hub**
8" x 2.165"
Balloon Cushion
270275



**R2
Poly Hub**
8" x 1.625"
Moldon Rubber
Tire 054046



**R3
Aluminum Offset
Hub**
8" x 1.625"
Moldon Rubber Tire
054048



**Z8
Poly Offset Hub**
8" x 2"
Solid Rubber
Tire
220352

5 CHOOSE AN OPTION.

Extension Options



Top extension for 40R, 40B, 41 and 45 handles
44UK - 44" top extension / 220347
52UK - 52" top extension / 220080
60UK - 60" top extension / 220081
68UK - 68" top extension / 220094
(Vinyl coated top extensions available - see price list)



Folding nose extension
20" long
F2 - For Cast Noses / 220346
F2E - For Extruded Noses 220082
30" long
F3 - For Cast Noses / 220343
F3E - For Extruded Noses / 220083

Stair Glide & Climber Options



S2K:
*Deluxe cast aluminum stair glides without wearstrip
220349

S3K: # 220351 with wearstrip



S4K
Steel stair glides with wearstrips
220340
Field Install Kit

S4F #054236
Factory Install



S5K
Continuous belt stair climbers
220339
(For 8" wheel only)
Field Install Kit
S5F #054237
Factory Install

Strap



CS
Center strap option
054062



Higher Capacity Convertible Trucks - 1,200 lbs. 2 Year Frame Warranty

COBRA JR. AND SR. FEATURES:

- 18" wide noseplate for large loads.
- Smooth and easy transition from the 2 to 4 wheeled position.
- Non-marking 5" x 1.25" swivel casters.
- Add B to end of part number for blue coated handle option.
- 8 rivets per cross brace. Welded release pedal.
- Custom advertising side strips available - contact dealer for details.
- 2" wide cross braces for added strength and advertising labels.

Cobra Jr.

- 2 Year Frame Warranty.
- Dual hand grips for improved control.
- 3 frame cross braces.
- 12 inch x 38 inch frame bed.



220291

OVERALL DIMENSIONS

w: 22" and 46.5"
h: 51.75" and 40"
d: 19"

Cobra Sr.

- 2 Year Frame Warranty.
- Continuous handle allows multiple ways to control load.
- 4 frame cross braces.
- 12 inch x 50.75 inch frame bed.



220290

OVERALL DIMENSIONS

w: 22" and 55.625"
h: 61.75" and 45.5"
d: 19"

	T18 Nose Part # Model #	18"W x 7.5"D 220293 CBR-JR-T18-PWT	18"W x 7.5"D 220291 CBR-JR-T18-PE	18"W x 7.5"D 220295 CBR-JR-T18-Z	18"W x 7.5"D 220297 CBR-JR-T18-Z2	18"W x 7.5"D 220622 CBR-JR-T18-CF	18"W x 7.5"D 220292 CBR-SR-T18-PWT	18"W x 7.5"D 220290 CBR-SR-T18-PE	18"W x 7.5"D 220294 CBR-SR-T18-Z	18"W x 7.5"D 220296 CBR-SR-T18-Z2	18"W x 7.5"D 220618 CBR-SR-T18-CF
	E18 Nose Part # Model #	18"W x 7.625"D 220482 CBR-JR-E18-PWT	18"W x 7.625"D 220494 CBR-JR-E18-PE	18"W x 7.625"D 220486 CBR-JR-E18-Z	18"W x 7.625"D 220490 CBR-JR-E18-Z2	18"W x 7.625"D 220515 CBR-JR-E18-CF	18"W x 7.625"D 220484 CBR-SR-E18-PWT	18"W x 7.625"D 220496 CBR-SR-E18-PE	18"W x 7.625"D 220488 CBR-SR-E18-Z	18"W x 7.625"D 220492 CBR-SR-E18-Z2	18"W x 7.625"D 220516 CBR-SR-E18-CF
	E16 Nose Part # Model #	16"W x 12"D 220483 CBR-JR-E16-PWT	16"W x 12"D 220495 CBR-JR-E16-PE	16"W x 12"D 220487 CBR-JR-E16-Z	16"W x 12"D 220491 CBR-JR-E16-Z2	16"W x 12"D 220666 CBR-JR-E16-CF	16"W x 12"D 220485 CBR-SR-E16-PWT	16"W x 12"D 220497 CBR-SR-E16-PE	16"W x 12"D 220489 CBR-SR-E16-Z	16"W x 12"D 220493 CBR-SR-E16-Z2	16"W x 12"D 220667 CBR-SR-E16-CF
	Capacity	600 lbs	600 lbs	600 lbs	600 lbs	560lbs	600 lbs	600 lbs	600 lbs	600 lbs	560lbs
	2 Wheel	1,200 lbs	1,200 lbs	1,200 lbs	1,200 lbs	1,160 lbs	1,200 lbs	1,200 lbs	1,200 lbs	1,200 lbs	1,160 lbs
	4 Wheel										
	Frame Bed	12" x 38"	12" x 38"	12" x 38"	12" x 38"	12" x 38"	12" x 50.75"	12" x 50.75"	12" x 50.75"	12" x 50.75"	12" x 50.75"
	Wheel	PWT	PE	Z	Z2	CF	PWT	PE	Z	Z2	CF
	Weight	39 lbs	37.5 lbs	43.5 lbs	42.5 lbs	41 lbs	42.5 lbs	41 lbs	47 lbs	46 lbs	41 lbs

Cobra Platform Deck Option

- Platform Deck: Slip resistant diamond pattern surface for both cast and extruded noseplate.



Part # Model #	220289 JRD	220288 SRD	220514 JRDE	220318 SRDE
For Use With	Jr/Cast Noseplate	Sr/Cast Noseplate	Jr/Extruded Noseplate	Sr/Extruded Noseplate
Length	42"	55"	42"	55"
Weight	8 lbs	10 lbs	7 lbs	9 lbs

Cobra Folding Nose Option

- Coated handle



	Kit for Field Installation			
	20" for T-18 Noseplates	20" for E-18 & E-16 Noseplates	30" for T-18 Noseplates	30" for E-18 & E-16 Noseplates
Part # Model #	220346 F2	220082 F2E	220343 F3	220083 F3E
	Factory Installed			
Part # Model #	054223 F2F	054202 F2EF	054225 F3F	054203 F3EF

PWT (Wide Tread) Steel Offset 10" x 3.5" Pneumatic	PE Steel Offset 10" x 3.5" Pneumatic	Z Steel Offset 10" x 2.75" Semi-Pneumatic	Z2 Poly Offset 10" x 2.75" Solid Rubber	CF (Flat Free) Steel Offset 10" x 3" Microcellular	BC-10 Poly Hub 10" x 2.165" Balloon Cushion
151507	151551	150589	150698	053446	150228

Spartan Economy Aluminum 2 in 1 Trucks

- Value-priced truck.
- Two sizes - Jr. and Sr.
- Sturdy, lightweight aluminum frame.
- 18" wide x 7.5" deep noseplate for large loads.
- Wheels: PE 10" pneumatic or SR 10" solid rubber.
- Non-marking 5" x 1.25" swivel casters.
- Pedal release allows easy conversion from 2-wheel to 4-wheel position.
- **Extra strength noseplate cast from special aluminum alloy.**
- Ships KD and boxed.
- **Assembly option available.** Add "-A" to Part # below. Example: 220000-A.

219998 - Spartan Jr.

OVERALL DIMENSIONS

w: 22"
h: 52" and 40"
d: 19"



220001 - Spartan Sr.

OVERALL DIMENSIONS

w: 22"
h: 61.5" and 45.5"
d: 19"



Spartan III

- Value priced truck.
- Aluminum construction.
- Quickly converts into 3 positions:
 1. Vertical 2-Wheel
 2. 45° 4-Wheel
 3. Platform Wheel.
- 18" x 7.5" cast aluminum noseplate.
- 7.5" W x 27" L recessed folding nose extension.
- Handle height 48".
- 10" full pneumatic wheel.
- 5" x 1.25" swivel casters.
- Ships KD/boxed.



270391

OVERALL DIMENSIONS

w: 21.5"
h: 52" and 42.25"
d: 19"

Part # Model #	220000 SPTN-JR-T18-PE	219998 SPTN-JR-T18-SR	220145 SPTN-JR-T18-CF	220001 SPTN-SR-T18-PE	219999 SPTN-SR-T18-SR	220144 SPTN-SR-T18-CF	270391 SPTN-III
Capacity							45' 4 Wheel - 500 lbs
4 Wheel	2 Wheel 1,000 lbs	500 lbs 1,000 lbs	500 lbs 1,000 lbs	500 lbs 1,000 lbs	500 lbs 1,000 lbs	500 lbs 1,000 lbs	2 Wheel - 500 lbs 4 Wheel - 750 lbs
Description	12" x 38" Bed	12" x 38" Bed	12" x 38" Bed	12" x 51" Bed	12" x 51" Bed	12" x 51" Bed	12" X 51" Bed
Wheel	PE	SR	CF	PE	SR	CF	PE
Caster	5" x 1.25"	5" x 1.25"	5" x 1.25"	5" x 1.25"	5" x 1.25"	5" x 1.25"	5" x 1.25"
Weight	44 lbs	54 lbs	44 lbs	46.3 lbs	58 lbs	48 lbs	45 lbs

PE Steel Offset 10" x 3.5" Pneumatic  151551	SR Poly Offset 10" x 2.5" Solid Rubber  108479	CF (Flat Free) Steel Offset 10" x 3" Microcellular  053446	PWT Steel Offset 10" x 3.625" Pneumatic  151507	Hub Steel Offset 8" x 2.25" Pneumatic  150146
--	--	--	---	---



BATTERY POWERED
COBRAPRO

Cobra PRO Jr. and Sr. have 950 Lb. capacity in 4-wheel mode and 600 Lb. capacity in 2-wheel mode on standard 17.5° ramp.

Spare Battery Module

- Part #220655
- Plugs directly into drive unit.
- No need to attach cables.
- Spare battery module includes 2 batteries and case.
- 25 lbs.

Cobra PRO Jr.



- 2 Year Frame Warranty.
- Dual hand grips for improved control.
- Variable speed fingertip control. Forward and reverse.
- 3 frame cross braces.
- Battery and charger included.

OVERALL DIMENSIONS

w: 22" or 46.5"
h: 51.75" or 40"
d: 19" or 19"



220653



220656 Shown with optional 30" folding nose #220343



Part #	220653	220656
Model #	PCBR-JR-T18-PWT	PCBR-SR-T18-PWT
Capacity		
2 Wheel	600 lbs	600 lbs
4 Wheel	1,200 lbs	1,200 lbs
Description	12" x 38"	12" x 50.75"
Wheel	10" PWT Pneumatic	10" PWT Pneumatic
Caster	5" x 1.25"	5" x 1.25"
Weight	109 lbs	112.5 lbs

CobraPRO Sr.



- 2 Year Frame Warranty.
- Continuous handle allows multiple ways to control load.
- Variable speed fingertip control. Forward and reverse.
- 4 frame cross braces.
- Battery and charger included.

OVERALL DIMENSIONS

w: 22" or 55.625"
h: 61.75" or 45.5"
d: 19" or 19"

PWT Steel Offset 10" x 3.625" Pneumatic



151507

Spartan and CobraPRO Options



	Spartan Jr. Models	CobraPRO Jr. Models	Spartan Sr. and CobraPRO Sr. Models	30" Folding Nose	
				Field Install	Factory Install
Part # Model #	220800 JRSD	220289 JRD	220288 SRD	220343 F3	054225 F3F
Length	42"	42"	55"	30"	30"
Weight	8 lbs	8 lbs	10 lbs	5 lbs	2 lbs

Platform Deck

30" Folding Nose



HD-UNI
Part #274100 with optional fold-out wheel carriage - #274102 and #274103 snap-on toe plate



HD-UNI
Part #274100 with optional snap-on toe plate - #274103.

OVERALL DIMENSIONS

w: 22"
h: 63"
d: 19"



HD-FOLD
Part #274101

OVERALL DIMENSIONS

w: 22"
h: 47" folded / 63" unfolded
d: 19"

Optional 274103 snap-on toe plate with 4 dual swivel casters



OVERALL DIMENSIONS

w: 22"
h: 53.5" folded / 70" unfolded
d: 21.3"

HD-EXTENDED FOLD

Part #274238
Extended Height HD
Complete with fold-out carriage.

Power LiftKar HD: 725 lb. high capacity models

- Three Models
- **Uni** – straight frame – accepts #274102 fold-out wheel carriage for 4-wheel support.
- **Fold** – upper handle angle can be adjusted. Best for copiers, safes, heavy motors or any short and heavy load which would require the user to pull the load back to a very low position for proper balance. The adjustable angle position on the Fold model allows the user to stand upright when using the truck at a very low angle.
- **Extended Fold** – Same advantages as **Fold** but with an extra 7" in height and fold-out wheel carriage.
- Innovative edge-of-step braking system – automatically applies brake when wheels are at edge of step. Helps prevent loss of load control caused by accidental rolling down steps.
- Brake can be shut off for use on level ground – prevents unwanted braking when moving over ground with an uneven surface.
- Two operating modes: single step (ascend or descend button must be pressed after each step – ideal for maximum control), or continuous climb.
- 24v quick-change battery pack – sealed maintenance-free battery.
- Battery, charger and 137" x 2" cargo belt included.
- 21" W x 7.25" D noseplate. Additional sizes available, contact Wesco Customer Service.
- Two climbing speeds: 6 steps/min. or 10 steps/min.
- Average number of steps with fully charged battery:
 - 440 lbs. of cargo - 220 steps
 - 550 lbs. of cargo - 190 steps
 - 725 lbs. of cargo - 120 steps.
- Maximum stair height 8.25".
- 1 year warranty on parts against defects in materials and workmanship.
- 6 month warranty on battery.

Power LiftKar Options

- **Part # 274103 - Snap-on toe plate** equipped with 4 dual casters. Provides additional cargo space and the ability to move loads without tilting truck. Especially useful in confined areas. 21" W x 14" D.
- **Part # 274102 - Fold-out rear wheel carriage** for Universal model only - slides easily into position to provide 4-wheel support.
- **Part # 274116 - Extra quick-change battery pack.**
- **Part # 274181 - In-transit 12 Volt DC auto charger.**
- **Part # 274185 - Standard 110 Volt battery charger.**



Part # Model	274100 Universal	274101 Fold	274238 Extended Height Fold
Battery	Single	Single	Single
Capacity	725 lbs	725 lbs	725 lbs
Height	63" straight frame	47" folded	70" straight frame
Belt	2 piece with clasp - 137" x 2"	2 piece with clasp - 137" x 2"	2 piece with clasp - 137" x 2"
Weight	96 lbs	97 lbs	105 lbs

4 EASY STEPS TO CONFIGURE YOUR LIFTKAR:

LIFTKAR[®] SAL

- Dual speed control on all models to fit your application.
- Quick-change battery and charger included.
- Pivoting and fixed handle configurations available to handle a wide variety of cargo.
- Choose from the long list of options to maximize the utility of your Liftkar.
- 240, 300 and 375 lb. capacity models.
- Climbs up to 48 steps per minute.
- All models include charger and battery.
- 1 year warranty on parts against defects in materials and workmanship.
- 6 month warranty on battery.

See the LIFTKAR video on our website! www.wescomfg.com

1 CHOOSE YOUR FRAME.

SAL-Ergo

- The ergo handle is the most popular all-purpose model with 3-handle gripping points providing proper balance for a variety of loads.
- (Recommended maximum cargo height - 58".)
(Shown with "G" Toe Plate.)



2 CHOOSE YOUR CAPACITY AND TIRE TYPE.

- Base Model - 240 lb capacity
- Base Model - 300 lb capacity
- Base Model - 375 lb capacity
See page 379 for 725 lb capacity HD models.
- Maximum number of steps with fully charged battery - all models:
200 - 300 steps - ascending
400 - 600 steps - descending

	Pneumatic Tire Part Number	Microcellular Tire Part Number	Capacity	Max. Steps per min	W x H	
240 lb Capacity Models - includes battery and charger						
Ergo	274140	274152	240 lbs	48	18.5" x 63"	42.7 lbs
Fold	274141	274153	240 lbs	48	18" x 61" unfolded/ 39.5 folded	42.2 lbs
Uni	274142	274154	240 lbs	48	17.5" x 59"	41.8 lbs
Fold-L	274143	274155	240 lbs	48	19" x 64.5" unfolded/ 51 folded	44.9 lbs
300 lb Capacity Models - includes battery and charger						
Ergo	274144	274156	300 lbs	35	18.5" x 63"	42.7 lbs
Fold	274145	274157	300 lbs	35	18" x 61" unfolded/ 39.5 folded	42.2 lbs
Uni	274146	274158	300 lbs	35	17.5" x 59"	41.8 lbs
Fold-L	274147	274159	300 lbs	35	19" x 64.5" unfolded/ 51 folded	44.9 lbs
375 lb Capacity Models - includes battery and charger						
Ergo	274148	274160	375 lbs	29	18.5" x 63"	42.7 lbs
Fold	274149	274161	375 lbs	29	18" x 61" unfolded/ 39.5 folded	42.2 lbs
Uni	274150	274162	375 lbs	29	17.5" x 59"	41.8 lbs
Fold-L	274151	274163	375 lbs	29	19" x 64.5" unfolded/ 51 folded	44.9 lbs

3 CHOOSE YOUR TOE PLATE.

- Add toe plate part number to base model number.

	Toe Plate Part Number	Grooved or Smooth*	W x D	Weight
G	274164	Grooved	16.5" x 13.4"	4.6 lbs
GS	274165	Grooved	18.8" x 9.4"	4.1 lbs
LH	274166	Smooth	18.45" x 10.9"	3.7 lbs
GS-NG	274167	Smooth	18.74" x 9.4"	4.1 lbs
DS-NG	274168	Smooth	17.7" x 7.5"	4.1 lbs
WL	274169	Grooved	14" x 7"	2.2 lbs
XWL	274170	Grooved	23.25" x 7"	3.9 lbs



Sal-Uni

- Ideal for tall, easily balanced loads.
 - 2-handle gripping points.
- (Shown with "G" Toe Plate.)*



Sal-Fold

- This model allows user to place handle in optimum position. Ideal for short, heavy loads that require truck to be tilted to an extreme angle for proper balance.
- (Shown with "G" Toe Plate.)*



Sal-Fold L

- Similar to fold but has a longer frame and shorter folding handle. This makes it ideal for loads that require less tilt for proper balance than the Fold provides.
- (Shown with "G" Toe Plate.)*



4 CHOOSE ACCESSORIES.



Part #274174
Keg Hook



Part #274199
2" Strap



Part #274177 or #274178
1" Strap



Part #274180
Extension Wings

	Part Number	Weight
Keg Hook	274174	1.2 lbs
Center Strap w/ extra crossbar - Uni and Ergo only	274175	1.1 lbs
Center Bar provides flat surface - Uni and Ergo only	274176	1.8 lbs
55" x 1" Cargo Strap w/buckle	274177	1.1 lbs
107" x 1" Cargo Strap w/buckle	274178	1.1 lbs
137" x 2" Cargo Strap w/buckle	274199	1.5 lbs
Panel / Window / Door Holder	274179	35.6 lbs
Extension Wings (Uni, Ergo, Fold-L)	274180	3.3 lbs
Cigarette Lighter Charger	274181	0.9 lbs
Battery Retainer	274104	1.0 lbs
Lifting System (Uni, Ergo, Fold-L)	274237	51 lbs
Extra Battery	274116	9.5 lbs

For detailed information on accessories, contact Wesco®.



Part #274237 Lift System in use
Not for use with toe plates WL or XWL.
Capacity: 265 lbs. Lift height: 35.5"



Part #274175
Center Strap



Part #274179
In use Door/Window Holder



Part #274176
Center Bar



Part# 230051
DC-66



Part# 230052
DC-72



StairKing Battery Powered Stair Climbing Appliance Truck

- U.S. Pat. No. 7,137,464
- Welded aluminum construction.
- 1/2 Horsepower, 50 amp, high torque motor runs cooler under load.
- Industrial grade gear box transmits steady power and is preferable to other drive designs.
- Large 2" diameter, polyurethane lifting feet provide more secure stair gripping.
- Auto rewind ratchet works first to take the slack out of the cargo belt, and then provides a ratchet crank to securely tighten the load.
- Noseplate measures 24" by 4" deep. Welded lightweight frame and noseplate.
- 30" from noseplate to center of belt.
- Sealed maintenance-free battery. AC charger and circuit breaker included.
- 6" moldon rubber wheels.
- Average number of steps with fully charged battery:

LOAD	STEPS
225 lbs	160
450 lbs	135
850 lbs	70

OVERALL DIMENSIONS

w: 24"
h: 66" or 72"
d: 12"

STAIRKING OPTIONS:



OVERALL DIMENSIONS

w: 11.5"
h: 4.5"
d: 20.5"

MSWK

- Superwheel attachment installs in seconds.
- Equipped with 10" x 4" full pneumatic tires. Provides 4 wheel support and eases transport over rough surfaces.

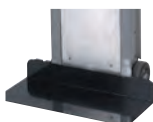

OVERALL DIMENSIONS

w: 28"
h: 4"
d: 12"



NE-28

- Toe plate extension. Easily clips on to standard toe plate and provides 12" deep x 28" wide cargo surface.

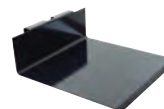

OVERALL DIMENSIONS

w: 20"
h: 7"
d: 20"



SP-20 Platform Option slips onto WLF forks

- Platform attachment. Slides in place over winch lift forks to provide a 20" x 20" lifting platform.

Part # Model	230051 DC-66	230052 DC-72
Capacity	850 lbs	850 lbs
Ratchet	Auto rewind	Auto rewind
Belt	2 piece w/clasp	2 piece w/clasp
Height	66" tall frame	72" tall frame
Weight	101 lbs	102 lbs

Part # Model #	270076 MSWK	230055 NE-28	260160 SP-20
Capacity	N/A	850 lbs	800 lbs
Description	Superwheel Option	Steel Nose Extension	Steel Slip on Platform
Weight	19 lbs	18 lbs	20 lbs

StairKing Battery Powered Stair Climbing Appliance Truck

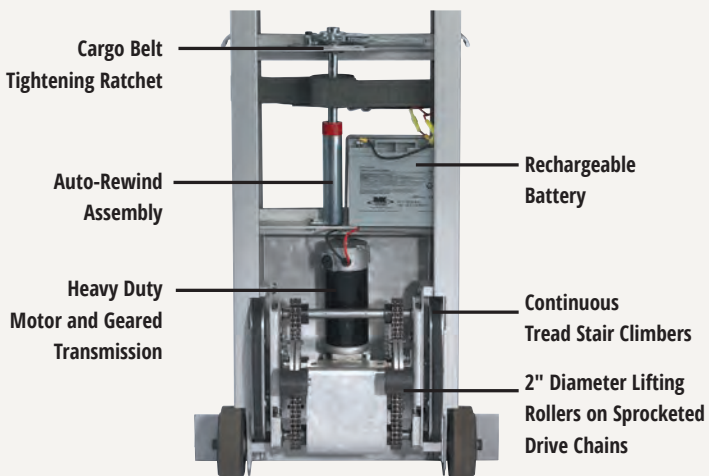

STAIRKING OPTIONS:



DC-66
with WLF Option

Part# 230053
WLF Winch Lift Option



Accessory Winch Lift for StairKing

- Optional aluminum winch lift attachment has 800 lb capacity.
- 3-1/2" swivel casters for 4 wheel support and mobility.
- Winch equipped with autobraking system.
- 18" forks, adjustable width 8.5" to 19" outside dimension.
- 57.25" lift height.
- Factory or field installation.

OVERALL DIMENSIONS

w: 25"
h: 70"
d: 30"



Part# 230060
Battery Charger Cord



Battery Charger Cord

- Charge battery while driving between stops.
- Plugs into cigarette lighter.
- Cable length 20'.
- Standard A.C. charger is included with truck purchase.



KOW Kick-out Wheel

- Kick-Out 3.5" casters for four wheel stability.

Part # Model #	230053 WLF	230059 KOW	230060 BC
Capacity	800 lbs	850 lbs	N/A
Description	Aluminum Winch Lift Attachment	Kick-out Wheel	Cigarette Lighter Charger
Weight	67 lbs	14 lbs	2 lbs

Economical Aluminum Appliance and Vending Trucks

- Exclusive Wesco ratchet design.
- Lightweight aluminum frame with auto rewind ratchet.
- Model AAP-612 has double ratchet design for greater cargo security.
- Model AVT-61 has four wheel swing-out design to support heavy loads and help reduce the strain of balancing the cargo over long distances.
- 6" x 2" molder rubber wheel, poly hub.
- Noseplate: 24" W x 5" D.



Part# 272412
AVT-61

OVERALL DIMENSIONS

w: 24"
h: 61"
d: 12"

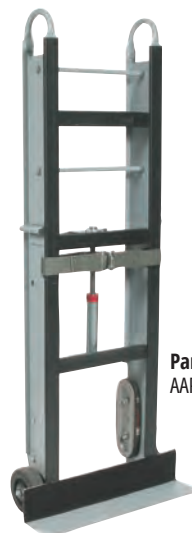

Part# 272410
AAP-61



Part# 272411
AAP-612

Part # Model #	272410 AAP-61	272411 AAP-612	272412 AVT-61
Capacity	550 lbs	550 lbs	550 lbs
Ratchet	Auto rewind	Auto rewind	Auto rewind
Belt	2 piece w/clasp	double 2 piece w/clasp	2 piece w/clasp
Wheel	6" x 2"	6" x 2"	6" x 2" (4" x 1" caster)
Weight	40 lbs	43 lbs	50 lbs

STEEL VENDING & APPLIANCE TRUCK FEATURES:

Welded frame and handles, non-marking grey vinyl, and 2" wide heavy duty web belt.



WRV-66



Wesco Steel Vending Machine Trucks

- Retractable moldon rubber casters (3.5" diameter)
- Heavy duty 8" cast iron center moldon rubber wheels with roller bearings
- Available with "Auto-Rewind" or "Manual" belt tightening systems
- 28.5" from noseplate to center of belt.
- 60" and 66" frame - 3/4"-14 Ga. steel tube.
- 72" frame - 1"-14 Ga. steel tube
- Noseplate 24" wide x 5" deep.



OVERALL DIMENSIONS
 w: 24"
 h: 60" & 66" & 72"
 d: 14.5"

Improved kick-out design allows operator to kick-out wheels with both hands on the truck.



WRC

Wesco Steel Appliance Truck

- All joints double welded for maximum durability.
- Rugged tubular steel construction.
- Available with "Auto-Rewind" or "Manual" belt tightening systems.
- Available with 6" x 2" wheels with 5/8" precision ball bearings.
- 26.5" from noseplate to center of belt.
- Noseplate 24" wide x 5" deep.

OVERALL DIMENSIONS
 w: 24"
 h: 59"
 d: 10"

Super Wheel

- 10" pneumatic rear wheels .
- Quick and easy turnbuckle mounting system.
- Converts a 2 wheel truck into a 4 wheel truck.
- **Note: Cannot be used on 72" WRV-72 Models.**



Part #270075
 Model #SSWK

Part # Model #	230035 WRV-60-EC	230017 WRV-60	230036 WRV-66-EC	230018 WRV-66	230037 WRV-72-EC	230019 WRV-72	230010 WRC	230028 WRC-EC
Capacity	1,200 lbs	1,200 lbs	1,200 lbs	1,200 lbs	1,200 lbs	1,200 lbs	750 lbs	750 lbs
Ratchet	Manual	Auto rewind	Manual	Auto rewind	Manual	Auto rewind	Auto rewind	Manual
Belt	1 piece	2 piece clasp	1 piece	2 piece clasp	1 piece	2 piece clasp	2 piece clasp	1 piece
Wheel	HB	HB	HB	HB	HB	HB	A	A
Height	60"	60"	66"	66"	72"	72"	59"	59"
Weight	80 lbs	80 lbs	86 lbs	86 lbs	95 lbs	95 lbs	52 lbs	52 lbs



230074



Heavy Duty Vending Trucks

- Front wheels have wheel locks to allow truck to be placed in upright position without the danger of the truck rolling away from operator. Wheel lock is activated by a conveniently located lever at top of truck.
- In transport position load rests on (2) 10" poly hub moldon rubber wheels and (2) 5" poly hub moldon rubber front wheels.
- Rear main wheel design allows truck to be tilted back to clear doorways. Especially useful with tall vending machines or other tall cargo.
- Available in 72" and 78" heights.
- 2 webbed cargo belts with ratchet tighteners for maximum load security.
- Constructed of heavy duty 1" diameter steel tubing.
- Noseplate - 5" D x 24" W x .25" thick.
- Tilts back at 49° angle.

OVERALL DIMENSIONS

w: 27"
h: 72" & 78"
d: 17"

OVERALL DIMENSIONS

w: 27"
h: 72" & 78"
d: 16"



230076

A Wesco Unique Design - Swivel casters may be deployed for easy steering and 4-wheel support



Heavy Duty Auto-Rewind Appliance Truck with Swivel Casters

- Truck can be used in 2-wheel or 4-wheel mode.
- Dynamic lever activated fulcrum system – fulcrum point changes as truck is tilted to decrease break-over effort.
- Swivel caster carriage kickout for four wheel support, lever release.
- 10" poly hub main wheels, 6" rear swivel casters.
- Available in 72" and 78" heights.
- 2 webbed cargo belts with ratchet tighteners for maximum load security.
- Constructed of heavy duty 1" diameter steel tubing.
- Noseplate - 5" D x 24" W x .25" thick.





Wesco Steel Vending Truck

- Dual handle control.
- 12" pneumatic wheels for rough terrain - #108484.
- Welded steel frame.
- One piece belt.
- 47" from noseplate to center of belt.
- 55" height.
- Noseplate - 4.94" D x 25" W x .25" thick.



230020

P12 Steel Offset 12" x 4" Pneumatic	10" x 2.5" Polyurethane Tread Polypropylene Hub
	
108484	053730

OVERALL DIMENSIONS

w: 28.5"
h: 55"
d: 20"

Part # Model #	230074 HDSV-72	230075 HDSV-78	230076 WRV-MAX-72	230077 WRV-MAX-78	230020 L-1
Capacity	1,800 lbs	1,800 lbs	1,800 lbs	1,800 lbs	700 lbs
Ratchet	Auto Rewind	Auto Rewind	Auto rewind	Auto rewind	N/A
Belt	2 piece w/clasp	2 piece w/clasp	2 piece w/clasp	2 piece w/clasp	1 piece clasp
Wheel	10" x 2.5" Poly	10" x 2.5" Poly	10" x 2.5" Poly	10" x 2.5" Poly	P-12
Noseplate	24"W x5"D	24"W x5"D	24"W x5"D	24"W x5"D	25"W x 5.2"D
Weight	126 lbs	129 lbs	120 lbs	130 lbs	62 lbs

REFERENCE SCHEMATIC FOR PAGES 46 & 47

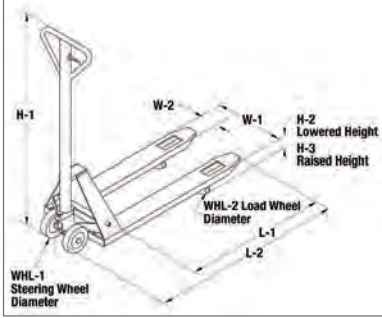

Deluxe Lowboy Models

- 5 year pump warranty.
- 2.125" lowered height.
- 6" non-marking moldon polyurethane steering wheel.
- 2" steel load wheels.
- 6.25" raised height.
- 6" wide gauge forks.
- 200° steering radius.



FOOT PUMP

Foot pedal gives you the option of using the foot pedal to raise the forks when space constraints make it difficult to use the standard handle to raise the load. **NO EXTRA COST**



Deluxe Foot Pump Model

- 5 year pump warranty.
- 7" non-marking moldon polyurethane steering wheel.
- 3" non-marking moldon polyurethane load wheel.
- All the same features and dimensions as Standard Deluxe Model 272748
- 6" wide gauge forks.
- 200° steering radius.



Deluxe Quick Lift Model

- 5 year pump warranty. US Patent No. 9, 102, 346.
- Fastest/quickest lift on the market.
- Just step on the pedal. **No pumping.** Lifts to 4.5"
- 7" non-marking moldon polyurethane steering wheel.
- 3" non-marking moldon polyurethane load wheels.
- All the same features and dimensions as Standard Deluxe models.
- Normal pump operation when load exceeds 300 lbs.
- 200° steering radius.

Part #	272760	272761	272762	272765	272766	272861
Capacity	5,500 lbs	5,500 lbs	5,500 lbs	5,500 lb	5,500 lbs	5,500 lbs /300 lb Q.L
W-1 x L-1	21" x 36"	21" x 42"	21" x 48"	27" x 48"	27" x 48"	27" x 48"
W-2	6"	6"	6"	6"	6"	6"
L-2	51"	57"	63"	63"	63"	63"
WHL-1 / WHL-2	6" / 2"	6" / 2"	6" / 2"	6" / 2"	8" / 3"	7" / 3"
H-1 / H-2 / H-3	46.5" / 2.125" / 6.25"	46.5" / 2.125" / 6.25"	46.5" / 2.125" / 6.25"	46.5" / 2.125" / 6.25"	48" / 3" / 8"	48" / 3" / 8"
Weight	134 lbs	143 lbs	148 lbs	157 lbs	170 lbs	166 lbs

DELUXE PALLET TRUCK FEATURES:

5 Year Pump Warranty, 5,500 lbs Capacity, Pump Overload Bypass, Rubber coated handle, Adjustable fork tie rods, Exit rollers, 200° steering, Tapered fork tips, 8 gauge 6" wide reinforced forks, Non-marking.

Pallet Truck Chock: High Visibility Yellow



FOR MORE PALLET TRUCK OPTIONS (Chocks and Guards) see page 58.



272748

Deluxe Standard Models

- 5 year pump warranty.
- 8" non-marking moldon polyurethane steering wheel
- 3" non-marking moldon polyurethane load wheels.
- 8" raised height.
- 3" lowered height.
- 6" wide forks.
- 200° steering radius.



27" Fork Width Setting

272744



21" Fork Width Setting



ADJUSTABLE FORK WIDTHS:

Two sizes of width, 16"-20" and 21"-27". Just loosen and reset front and rear adjusting bolts.

A Wesco exclusive. One truck to do the work of two!

Deluxe Adjustable Fork Model

- 5 year pump warranty.
- US Patent No. 6, 808, 357.
- Available in 16" or 21" widths.
- 7" non-marking moldon polyurethane steering wheel.
- 3" non-marking moldon polyurethane load wheels.
- 7.75" raised height: 3" lowered height.
- 6" wide gauge forks.
- 200° steering radius.

Part #	272136	272142	272148	272736	272742	272748	272744	272747	272746
Capacity	5,500 lbs	5,500 lbs	5,500 lbs	5,500 lbs	5,500 lbs	5,500 lbs	5,500 lbs	5,500 lbs	5,500 lbs.
W-1 x L-1	21" x 36"	21" x 42"	21" x 48"	27" x 36"	27" x 42"	27" x 48"	21" - 27" x 48"	16" - 20" x 36"	16" - 20" x 48"
W-2	6"	6"	6"	6"	6"	6"	6"	6"	6"
L-2	51"	57"	63"	51"	57"	63"	61"	49"	61"
WHL-1 / WHL-2	8" / 3"	8" / 3"	8" / 3"	8" / 3"	8" / 3"	8" / 3"	7" / 3"	7" / 3"	7" / 3"
H-1 / H-2 / H-3	48" / 3" / 8"	48" / 3" / 8"	48" / 3" / 8"	48" / 3" / 8"	48" / 3" / 8"	48" / 3" / 8"	47" / 3" / 7.75"	47" / 3" / 7.75"	47" / 3" / 7.75"
Weight	143 lbs	152 lbs	157 lbs	151 lbs	161 lbs	166 lbs	180 lbs	147.5 lbs	157 lbs

**WESCO®
ADVANTAGE™**

REFERENCE SCHEMATIC FOR PAGES 48 & 49

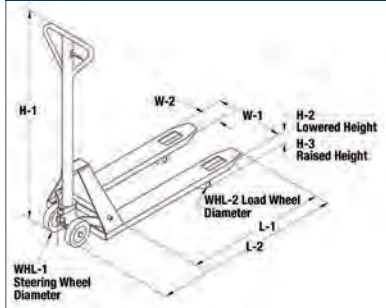

Advantage™ Pallet Trucks

- 3 year pump warranty.
- Leak proof hydraulics
- Quick Lift pump only 12 strokes to full lift
- 190 degree turning for maneuverability.
- 3 position hand control - Raise, Lower, Neutral
- Durable epoxy powder coat finish
- Fully welded joints and reinforced fork tips
- Exceptionally strong and light weight at 120 lbs

**WESCO®
ADVANTAGE™
PRO**

**Pallet Truck Chock:
High Visibility Yellow**

FOR MORE PALLET TRUCK OPTIONS
(Chocks and Guards) see page 58.



Advantage™ PRO Pallet Trucks

- 3 year pump warranty.
- Advanced leak proof pump design
- Full capacity 5500 and 6500 pound models available
- 12 grease fittings and an adjustable packing nut for extended life
- Reinforced A-Frame design
- 210 degree steering provides improved maneuverability in tight spots
- Premium rubber coated handles for secure and comfortable grip
- High quality 3-position hand control combined with a standard foot pedal release for load control
- Precise valving provides variable lowering speed
- Standard entry and exit rollers for smooth effortless operation
- 12 lubrication grease nipples on all movable parts for easy maintenance

Part #	274705	274706	272149	274708	274709	274710	274711	274730	274731	274732	274733
Capacity	1,100 lbs	4,400 lbs	4,400 lbs	5,500 lbs	5,500 lbs	6,600 lbs	6,600 lbs				
W-1 x L-1	15" x 31.5"	21" x 48"	27" x 48"	21" x 48"	27" x 48"	21" x 48"	27" x 48"	21" x 36"	21" x 42"	27" x 36"	27" x 42"
W-2	6.3"	6"	6"	6"	6"	6"	6"				
L-2	44.5"	60"	63"	63"	63"	63"	63"				
WHL-1 / WHL-2	5" / 2.25"	6" / 3"	6" / 3"	8" / 3"	8" / 3"	8" / 3"	8" / 3"				
H-1 / H-2 / H-3	44.5" / 2.5" / 6"	46.5" / 2.9" / 7.5"	46.5" / 2.9" / 7.5"	48" / 3.3" / 8"	48" / 3.3" / 8"	48" / 3.3" / 8"	48" / 3.3" / 8"				
Weight	78 lbs	117 lbs	136 lbs	133 lbs	142 lbs	157 lbs	166 lbs				

ADVANTAGE PALLET TRUCK FEATURES:

Introducing Wesco's Advantage™ Line of Pallet Trucks

Entire Advantage™ line is backed by a 3 year warranty. The Advantage offers the best choice for the "value" user, offering full pallet truck features at an economical price. The AdvantagePro is our high quality, heavy duty design for the professional user. AdvantagePro-Max trucks are the ultimate tool when faced with overcapacity load situations or when you need that extra heavy duty construction to last a lifetime.

WESCO ADVANTAGE™ PRO-MAX



Advantage™ PRO-MAX Pallet Trucks

- 3 year pump warranty.
- Two stage pump doubles the lifting speed for loads under 1200 pounds. Shifts automatically to handle heavier loads.
- Impact free lifting ensures safety of cargo loading.
- Integral overload protection included in the pump hydraulic circuit
- Structural extreme service design guarantees safety and durability
- Frame constructed using high strength steel plate for light weight and strength.

Advantage™ PRO-MAX All-Terrain Pallet Truck

- 3 year pump warranty.
- Large, easy-rolling pneumatic wheels allows for easy movement over rugged terrain - indoor our outdoor
- Easy-to-operate 3-position pump handle features up, down and neutral positions
- Pneumatic wheels have sealed bearings for dust protection and outdoor durability

Advantage™ PRO-MAX Scale Pallet Truck

- 3 year pump warranty.
- Large and bright LED display
- Keypad with automatic tare function
- Power supply with rechargeable battery or with 86-264V AC input

Part #	274714	274715	274718	274720
Capacity	7,700 lbs	11,000 lbs	3,300 lbs	4,400 lbs
W-1 x L-1	27" x 48"	27" x 48"	63.25" OR 9"-29" X 32"	27" X 45"
W-2	6"	6"	4"	6"
L-2	63"	64"	51"	62"
WHL-1 / WHL-2	7" / 3"	7" / 3"	10" / 15"	6" / 3"
H-1/H-2/H-3	48" / 2.9" / 7.5"	49" / 3" / 7.5"	51" / 2.75" / 9.5"	47 / 3.3 / 7
Weight	221 lbs	243 lbs	424 lbs	314 lbs

SEE PAGE 48 FOR SCHEMATIC DRAWING.

REFERENCE SCHEMATIC FOR PAGES 50 & 51

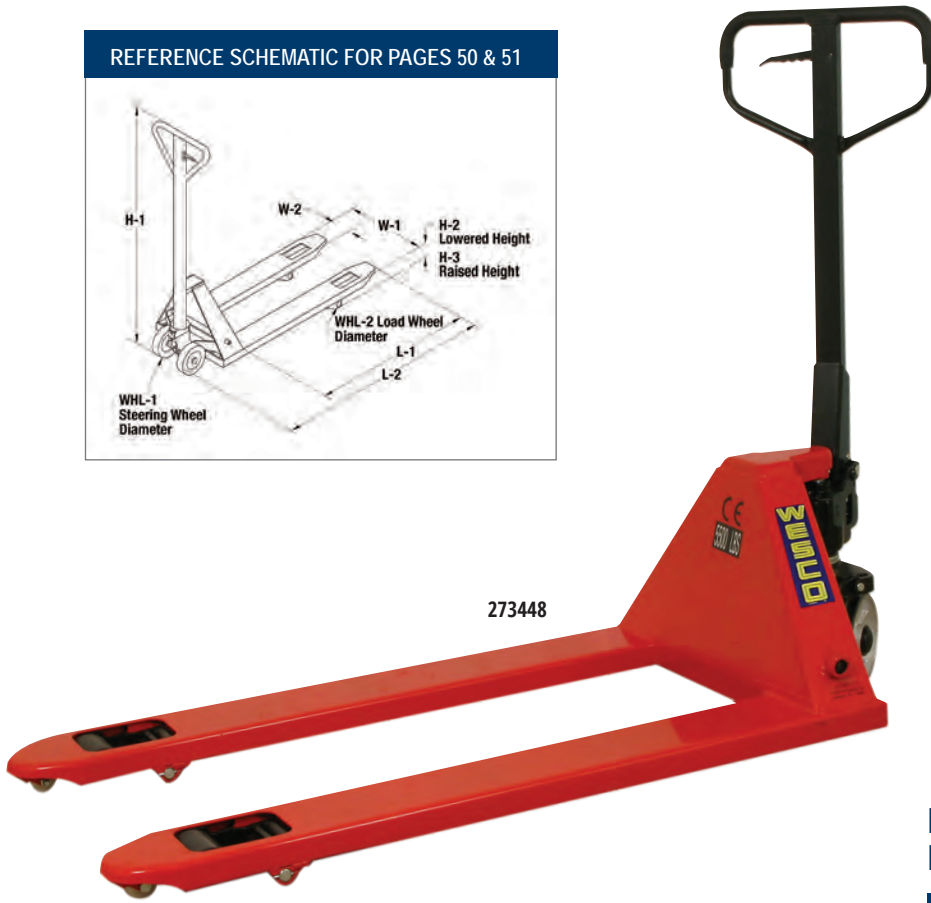
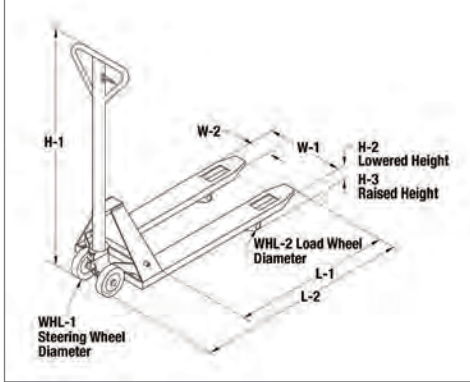

CP3 Pallet Truck

- 2 year pump warranty.
- 3 mm thick forks.
- Adjustable fork connecting rods.
- Overload bypass.
- Rubber coated handle.
- 7" moldon polyurethane steering wheels.
- 3" moldon polyurethane load wheels.
- Entry and Exit Rollers.
- 210° steering radius.

**Pallet Truck Chock:
High Visibility Yellow**

FOR MORE PALLET TRUCK OPTIONS
(Chocks and Guards) see page 58.



Part #	272854	272656	272657	272658	272659	272660	273453	273454	273448
Capacity	5,500 lbs	5,500 lbs	5,500 lbs	5,500 lbs	5,500 lbs	5,500 lbs	5,500 lbs	5,500 lbs	5,500 lbs
W-1 x L-1	18"W x 48"L	21"W x 42"L	21"W x 48"L	27"W x 36"L	27"W x 42"L	27"W x 48"L	21" x 36"	21" x 48"	27" x 48"
W-2	6.25"	6.25"	6.25"	6.25"	6.25"	6.25"	6.25"	6.25"	6.25"
L-2	63"	57"	63"	51"	57"	63"	51"	63"	63"
WHL-1 / WHL-2	7" / 3"	7" / 3"	7" / 3"	7" / 3"	7" / 3"	7" / 3"	7" / 3"	7" / 3"	7" / 3"
H-1/H-2/H-3	48.25" / 29" / 7.25"	48.25" / 29" / 7.25"	48.25" / 29" / 7.25"	48.25" / 29" / 7.25"	48.25" / 29" / 7.25"	48.25" / 29" / 7.25"	48.25" / 29" / 7.25"	48.25" / 29" / 7.25"	48.25" / 29" / 7.25"
Weight	171 lbs	161.5 lbs	169.5 lbs	162 lbs	171 lbs	180 lbs	139 lbs	152.5 lbs	164.5 lbs

CP PALLET TRUCK FEATURES:

2 Year Pump Warranty, 5,500 / 6,600 / 4,400 LB Capacities, Rubber coated handle, Adjustable fork tie rods, Entry/exit rollers.



CPII Pallet Truck

- 2 year pump warranty.
- 2 Models - polyurethane or nylon wheels.
- Adjustable fork connecting rods.
- Entry/exit rollers.
- Overload bypass.
- Reinforced forks - 11 Gauge.
- Rubber coated handle.
- Raised height: 8". Lowered height: 3".
- 7" wide forks.
- 8" moldon polyurethane or 8" nylon steering wheels.
- 3" moldon polyurethane or nylon load wheels.
- 180° steering radius.



CPIIHD Pallet Truck

- 2 year pump warranty.
- High capacity rating.
- Adjustable fork connecting rods.
- Entry/exit rollers.
- Overload bypass.
- Reinforced forks - 4mm thick.
- Rubber coated handle.
- 7" wide forks.
- 8" moldon polyurethane steering wheels.
- 3" moldon polyurethane load wheels.
- 180° steering radius.

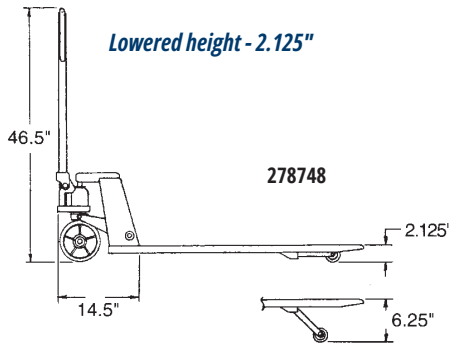

CPII Lowboy Pallet Truck

- 2 year pump warranty.
- Many features are the same as CPII.
- Lowered height of 2.125".
- 7" wide 4mm thick forks.
- 7" moldon polyurethane steering wheels.
- 2" steel load wheels.
- 180° steering radius.

	Polyurethane Wheels		Nylon Wheels						
Part #	272777	272778	272775	272776	272670	278136	278142	278148	278748
Capacity	5,500 lbs	5,500 lbs	5,500 lbs	5,500 lbs	6,600 lbs	4,400 lbs	4,400 lbs	4,400 lbs	4,400 lbs
W-1 x L-1	21" x 48"	27" x 48"	21" x 48"	27" x 48"	27" x 48"	21" x 36"	21" x 42"	21" x 48"	27" x 48"
W-2	7"	7"	7"	7"	7"	7"	7"	7"	7"
L-2	63"	63"	63"	63"	63"	51"	57"	63"	63"
WHL-1 / WHL-2	8" / 3"	8" / 3"	8" / 3"	8" / 3"	8" / 3"	7" / 2"	7" / 2"	7" / 2"	7" / 2"
H-1/H-2/H-3	48" / 3" / 8"	48" / 3" / 8"	48" / 3" / 8"	48" / 3" / 8"	48" / 3" / 8"	46.5" / 2.125" / 6.25"	46.5" / 2.125" / 6.25"	46.5" / 2.125" / 6.25"	46.5" / 2.125" / 6.25"
Weight	170 lbs	176 lbs	159.5 lbs	169 lbs	220 lbs	226 lbs	235 lbs	240 lbs	249 lbs

LOOK

SEE PAGE 50 FOR SCHEMATIC DRAWING.

**WESCO®
ADVANTAGE™
POWER**



Advantage™ Power Semi-Electric Pallet Trucks

- 3 year pump warranty.
- 24 Volt lithium battery, 20AH capacity
- Tight turning radius for maneuverability
- Permanent magnet brushless motor
- Stepless controls for accurate speed control
- **Separate charger: Part# 274700 & 274701**
Built-in charger: Part# 274702
- **Part# 274702** provides extra power for high volume use, heavy duty drive, constant speed loaded or unloaded and rotating balance wheels for improved stability

**WESCO®
ADVANTAGE™
PRO-POWER**



Advantage™ PRO-Power Fully Electric Pallet Trucks

- 3 year pump warranty.
- Speed: 2.6 / 2.8 mph loaded/unloaded
- Tight turning radius for maneuverability
- **Part# 274703:** 24 Volt lithium battery 30AH capacity
- **Part# 273922 & 273923:** 48 Volt lithium battery 20AH capacity
- 3 hour recharge quick change battery
- Protected battery compartment
- Permanent magnet high efficiency brushless motor
- Stepless controls for accurate speed control control
- Battery meter with charge indicator light on handle

Part#	274702	274703	273922	273923
Capacity	3,300 lbs	3,300 lbs	2,640 lbs	3,300 lbs
W-1 x L-1	27" x 48"	27" x 48"	27" x 48"	27" x 48"
W-2	6"	6"	6"	6"
L-2	67.5"	65"	67"	67"
WHL-1 / WHL-2	8" / 3"	8" / 3"	10" / 3"	10" / 3"
H-1/H-2/H-3	49.5"/33"/7.5"	47.25"/3"/7.5"	47.25"/3"/7.5"	47.25"/3"/7.5"
Weight	441 lbs	252 lbs	309 lbs	320 lbs

ADVANTAGE PALLET TRUCK FEATURES:

Introducing Wesco's Advantage™ Line of Pallet Trucks

Entire Advantage™ line is backed by a 3 year warranty. The Advantage Power semi-electric heavy-duty pallet trucks feature a compact design. Advantage Pro-Power trucks with quick charge batteries provide unmatched flexibility and highest productivity in the toughest and most demanding job sites. The Advantage Pro-Max Power for the ultimate in heavy duty loads and severe service that won't let you down.

WESCO ADVANTAGE™ PRO-MAX POWER

REFERENCE SCHEMATIC FOR PAGES 52 & 53

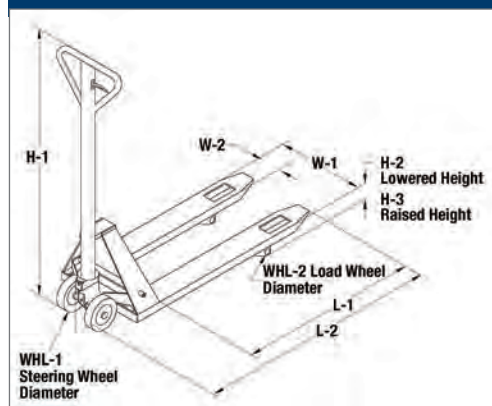

Advantage™ PRO-MAX Heavy Duty Power Pallet Truck

- 3 year pump warranty.
- 4,000 or 4,400 lb capacity
- 24 Volt battery with 105AH capacity
- High travel speed: 3.3 / 3.6 mph loaded/unloaded
- Compact design with 53" turning radius
- Controls operate with handle raised for tight spaces
- DC permanent magnet brushless motor
- Stepless controls for accurate speed control
- Battery meter with charge indicator light on handle



274724



274723

Part #	274723	274724
Capacity	4,400 lbs	4,000 lbs
W-1 x L-1	27" x 48"	27" x 45"
W-2	6"	6"
L-2	63"	65"
WHL-1 / WHL-2	8" / 3"	10" / 3"
H-1 / H-2 / H-3	51.5" / 3.3" / 7.5"	48.5" / 3.3" / 8"
Weight	552 lbs	1,180 lbs

Pallet Truck Chock: High Visibility Yellow



FOR MORE PALLET TRUCK OPTIONS
(Chocks and Guards) see page 58.



273400

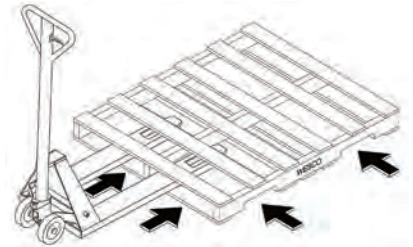

4-Way Pallet Truck

- 3 year pump warranty.
- Overload bypass.
- Reinforced forks - 4mm thick.
- Rubber coated handle.
- 180° steering radius.
- Can enter pallet from all 4 sides.
- Adjustable fork connecting rods.
- Steel 1.70" load wheels.
- 6" polyurethane steering wheels.

Not For Legal Trade



272936

Scale Truck

- NOT FOR LEGAL TRADE.
- 2 year pump warranty.
- Weighing accuracy ±4.4 lbs., or 2.0 Kg.
- LED display scale.
- Mettler-Toledo Hawk scale/sensor.
- UL approved scale operates on rechargeable battery. May be plugged into AC and used while recharging.
- Replacement Battery Pack #272849.
- Self-contained battery charger.
- Three position hand control.
- 205° steering radius.
- 7" wide forks.
- 7" moldon polyurethane steering wheels.
- 3" moldon polyurethane load wheels.



Look - Brake



272667

**Pallet Truck With
Hand Brake**

- 2 year pump warranty.
- All the same features as the CPI model.
- 6" wide forks.
- 7" moldon rubber steering wheels.
- 3" moldon polyurethane load wheels.
- Disc brake.
- Tandem load wheels.
- Nylon entry rollers.
- 210° steering radius.

Part # Model #	272936 SPT27	272938 SPT22	272667	273400
Capacity	5,000 lbs	5,000 lbs	5,500 lbs	4,000 lbs
W-1 x L-1	27.5" x 47.5"	22.5" x 47.5"	27" x 48"	33" x 48"
W-2	7"	7"	6"	7"
L-2	62.5"	62.5"	63"	63.5"
WHL-1 / WHL-2	7" / 3"	7" / 3"	7" / 3"	6" / 1.70"
H-1 / H-2 / H-3	48.25" / 2.9" / 8"	48.25" / 2.9" / 8"	48.25" / 2.9" / 7.25"	47" / 1.75" / 6"
Weight	336 lbs	314 lbs	206 lbs	241 lbs

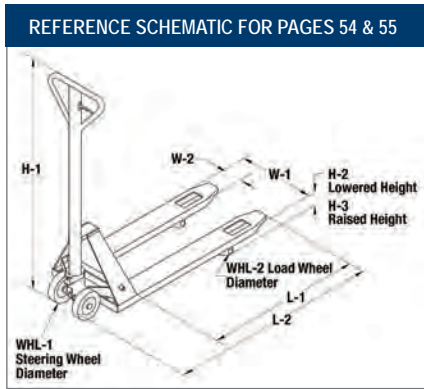

New Transroller Pallet Truck
273500

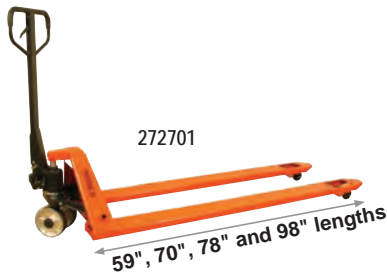

Long Fork Pallet Truck

- 2 year pump warranty.
- Pump, load wheels and steering wheels same as CPI model.
- Overload bypass.
- Rubber coated handle.
- 7" moldon polyurethane steering wheels.
- 3" moldon polyurethane load wheels.
- 78" and 98" forks handle 2 standard size pallets.
- Nylon entry rollers.
- 210° steering radius.

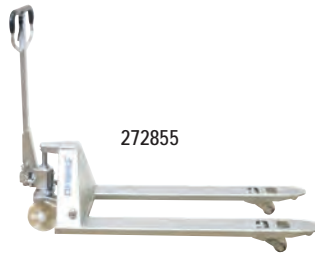

Galvanized Truck

- 1 year pump warranty.
- 7" nylon steering wheels.
- 3" nylon load wheels.
- Galvanized frame and handle.
- Nylon entry rollers.
- 210° steering radius.
- Comfort-grip coated handle.



Stainless Steel Pallet Truck

- 1 year pump warranty.
- For use in food industry and areas where corrosive solutions are needed.
- 6 1/4" wide forks.
- 7" nylon steering wheels.
- 3" nylon load wheels.
- Nylon entry rollers.
- 210° steering radius.
- Comfort-grip coated handle.

Part # Model #	273500	273585 PT59	272701 PT70	273519 PT78	273586 PT98	272855 GPT	272152 SSPT
Capacity	Standard - 5,000 lbs/ Lateral 2,200 lbs	4,400 lbs	4,400 lbs	4,400 lbs	3,300 lbs	5,500 lbs	5,500 lbs
W-1 x L-1	27" x 48"	27" x 59"	27" x 70"	27" x 78"	27" x 98"	27" x 48"	27" x 48"
W-2	7"	6"	6"	6"	6"	6.25"	6.25"
L-2	63"	75"	86"	93"	114"	62.5"	62.5"
WHL-1 / WHL-2	8" / 3"	7" / 3"	7" / 3"	7" / 3"	7" / 3"	7" / 3"	7" / 3"
H-1 / H-2 / H-3	Std. mode - 48" / 3.4" / 7" Lateral mode - 48" / 3.4" / 8.5"	48" / 3" / 7"	49" / 3" / 8"	49" / 3" / 8"	48" / 3" / 7"	47.5" / 3" / 7.25"	47.5" / 3" / 7.25"
Weight	210 lbs	220 lbs	244 lbs	256 lbs	347 lbs	155 lbs	164 lbs

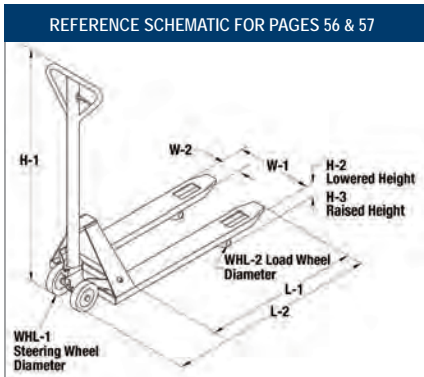

272950



Ergonomic Pallet Tilter

- 1 year pump warranty.
- 5" polyurethane swivel casters and 3" polyurethane load wheels.
- Handle height: 44 1/4".
- Load center: min 7 1/2", max. 15 1/2".
- Lifting range with forks in horizontal position: 3 1/4" to 11".
- Forks tilt up to 90° for accurate load positioning.
- Lifting range with back rest in horizontal position: 29" to 37".
- 6 1/2" wide forks.



273250

Drum Pallet Truck

- 1 year pump warranty.
- For 55-gallon steel drums.
- Lifts drum 4" off ground.
- 8" x 2" nylon steering wheels.
- 3" x 1" nylon load wheels.
- Drum ring raised height - 14.5"
- Drum ring lowered height - 10.25"



272153

Pallet Lifter

- 1 year pump warranty.
- Heavy duty steel construction.
- Pallets with bottom boards must be placed on top of forks.
- 6 1/2" wide forks.
- 6" polyurethane swivel casters.
- 2" polyurethane load wheels.

Part # Model #	272950 ERPT	273250 PTDL	272153 PLFTR
Capacity	2,200 lbs	660 lbs	1,100 lbs
W-1 x L-1	21.5" x 31"	28.5" x 26"	27" x 44"
W-2	6.5"	2.5"	6.5"
L-2	51.67"	41"	61.5"
WHL-1 / WHL-2	5" / 3"	8" / 3"	6" / 2"
H-1 / H-2 / H-3	44.25" / 3.25" / 11"	47.75" / 3" / 8"	40" / 3.5" / 35"
Weight	392 lbs	115 lbs	258 lbs



272754
Telescoping

272463
Non-Telescoping

Manual High Lifts

- 1 year pump warranty.
- Two models: Telescoping and Non-Telescoping.
- Moldon polyurethane wheels.
- Loop handles with inside hand control.
- Closed pallets must be placed on top of forks.
- 180° steering radius.
- Comfort coated handles.
- Two stage pump with Quick Lift.

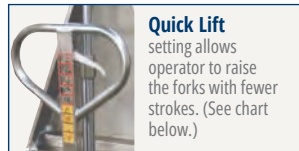

Quick Lift
setting allows operator to raise the forks with fewer strokes. (See chart below.)

Stainless Steel Manual High Lift #272859

- 1 year pump warranty.
- 3" nylon load (WHL-2) and 8" nylon steering (WHL-1) wheels.
- 180° steering radius.
- 304 stainless steel construction, except for 316 stainless forks.

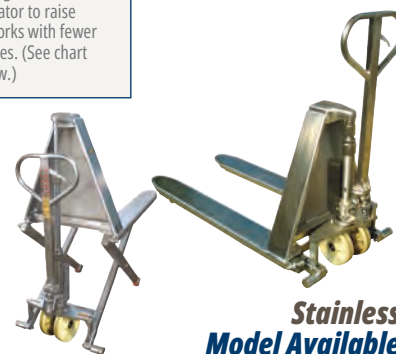

Stainless Model Available
272859 Stainless Steel Manual High Lift

		304 Stainless Steel					
Part # Model #	272859 SSTHL27M	272755 TSHL21	272754 TSHL27	272462 NTSHL21	272463 NTSHL27	272975 TSHL20-33	272976 TSHL27-33
Capacity	2,200 lbs	2,200 lbs	2,200 lbs	2,200 lbs	2,200 lbs	3,300 lbs	3,300 lbs
W-1 x L-1	27" x 46"	21" x 44.5"	27" x 44.5"	21" x 44.5"	27" x 44.5"	20" x 43"	27" x 43"
W-2	6.5"	6.5"	6.5"	6.5"	6.5"	6.5"	6.5"
L-2	61"	63"	63"	56"	56"	63"	63"
WHL-1 / WHL-2	8" / 3"	6" / 3"	6" / 3"	6" / 3"	6" / 3"	6" / 3"	6" / 3"
H-1 / H-2 / H-3	48" / 3.3" / 31.5"	48.5" / 3.6" / 31.5"	48.5" / 3.3" / 31.5"	48.5" / 3.3" / 31.5"	48.5" / 3.6" / 31.5"	48.5" / 3.6" / 31.5"	48.5" / 3.6" / 31.5"
Telescoping	Yes	Yes	Yes	No	No	Yes	Yes
Weight	278 lbs	219 lbs	228 lbs	275 lbs	300 lbs	260 lbs	276 lbs
# OF PUMP STROKES TO REACH FULL HEIGHT							
Quick Lift	28	28	28	28	28	21	21
Standard	69	67	67	35	35	63	63



272461
Non-Telescoping Models - charger built in.

272937
Telescoping Models - charger separate.

Electric High Lifts

- 1 year pump warranty.
- Two models: Telescoping and Non-Telescoping.
- 12 volt battery charger included.
- 10-12 second lift time unloaded.
- Overload bypass.
- Polyurethane wheels.
- 180° steering radius.
- Comfort coated handles.
- 6 1/2" wide forks.
- 6" moldon polyurethane steering wheels.
- 3" moldon polyurethane load wheels.

Stainless Steel Electric High Lift #272860

- 1 year pump warranty.
- 3" nylon load (WHL-2) and 8" nylon steering (WHL-1) wheels.
- 180° steering radius.
- 304 stainless steel construction, except for 316 stainless forks.

Stainless Model Available

272860
Stainless Steel Electric High Lift



		304 Stainless Steel			
Part # Model #	272860 SSTHL27E	272939 TEHL21	272937 TEHL27	272460 NTEHL21	272461 NTEHL27
Capacity	2,200 lbs	3,000 lbs	3,000 lbs	2,200 lbs	2,200 lbs
W-1 x L-1	27" x 46"	21" x 45"	27" x 45"	21" x 45"	27" x 45"
W-2	6.5"	6.5"	6.5"	6.5"	6.5"
L-2	61"	60"	60"	60"	63"
WHL-1 / WHL-2	8" / 3"	6" / 3"	6" / 3"	6" / 3"	6" / 3"
H-1 / H-2 / H-3	48" / 3.3" / 31.5"	48.5" / 3.3" / 31"	48.5" / 3.3" / 31"	48.5" / 3.3" / 31"	48.5" / 3.3" / 31"
Telescoping	Yes	Yes	Yes	No	No
Weight	329 lbs	344 lbs	347 lbs	367 lbs	372 lbs

EASY AS 1-2-3-GO!



Two Models to Secure Your Pallet Jack

- Both models function well on any surface and will resist slipping.
- To secure pallet jack, simply roll steering wheels up the pallet jack stop or chock incline and into holding area.



Pallet Jack Stop

- Material: black hard rubber.
- Part # 272949
- Weight 3.5 lbs

OVERALL DIMENSIONS

w: 11.75"
h: 2"
d: 14"



Pallet Truck Chock - High Visibility Yellow

- Material: yellow hard rubber.
- Part # 272175
- Weight 3.4 lbs

OVERALL DIMENSIONS

w: 11.75"
h: 2"
d: 14"



Milk Crate Guard



Box Guard

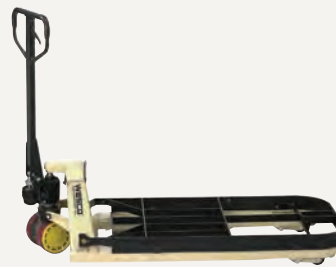

Skid Adapter

3 in 1 Guard Adapter

- Fits only specific Wesco 27" W pallet trucks: long fork, with brake, CPI and CP3 models.
- Easily attaches to Wesco CPI pallet truck.
- Factory or field installed.
- #272660 CPI Pallet Truck with Mounted Guard - Part #272654 - 245 lbs.
- Guard only kit, field install. Part #272004 - 54 lbs.

3 in 1 Guard featured as an option is three products in one compact design. You no longer need to purchase separate milk crate guards, box guards or skid adapters. Wesco's 3 in 1 guard does it all.

Cargo Backrest

- Fits only specific Wesco 27" W pallet trucks: long fork, with brake, CPI and CP3 models.
- Easy attachment, no drilling, can be field retrofitted.
- Field or factory installed.
- Backrest Only Kit - Part #271999 - 42 lbs.
- Part #272296 - 213 lbs. Assembled CP3 Pallet Truck #272660 with Mounted Backrest #271999.

Backrest
271999

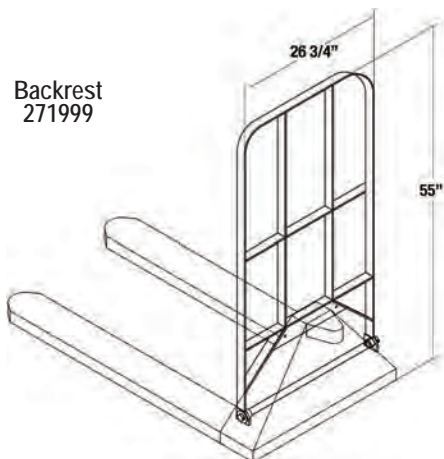

3 in 1 Guard
272004

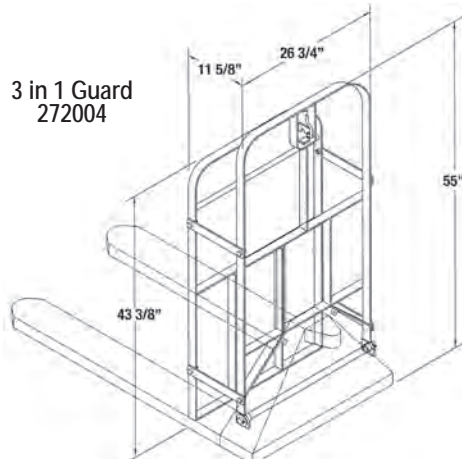

3 in 1 Guard and Cargo Backrest designed for use only on specific Wesco Pallet Trucks. Use on trucks other than Wesco void any and all warranties.

Steel Frame Pedalift Features:

750 lb lift capacity, Wheel locks are standard on all models, Frame and lift heights vary among models.



WPL-54-2222



WPL-54-F



Two Wheeled Winch Models

- 1-year warranty.
- Manual winch with auto-brake.
- Low maintenance design.
- Front of platform touches the ground on two wheeled model.
- Wheel lock standard.
- All 54" lifts are 60.5" O.A.H. All 40" lifts are 48.5" O.A.H.
- 8" x 2" wheels with .75" precision ball bearings.
- Adjustable forks.

OVERALL DIMENSIONS

w:	22.5"	22.5"	30"	22.5"	22.5"
h:	48.5"	60.5"	60.5"	48.5"	60.5"
d:	32"	32"	32"	32"	32"



WDPL-54-2222



WDPL-54-F



Four Wheeled Winch Models

- 1-year warranty.
- Manual winch with auto-brake.
- Low maintenance design.
- Platform on four wheeled model sits 5.75" above the floor.
- Wheel lock standard.
- All 54" lifts are 60.5" O.A.H. All 40" lifts are 48.5" O.A.H.
- 8" x 2" wheels with .75" precision ball bearings.
- 3.5" diameter polyurethane ball bearing front swivel casters.
- Adjustable forks.

OVERALL DIMENSIONS

w:	22.5"	22.5"	30"	22.5"	22.5"
h:	48.5"	60.5"	60.5"	48.5"	60.5"
d:	32"	32"	32"	32"	32"

Part # Model #	260015 WPL-40-1620	260016 WPL-54-2222	260017 WPL-54-2230	260018 WPL-40-F	260019 WPL-54-F	260020 WDPL-40-1620	260021 WDPL-54-2222	260022 WDPL-54-2230	260023 WDPL-40-F	260024 WDPL-54-F
Capacity	750 lbs	750 lbs	750 lbs	750 lbs	750 lbs	750 lbs	750 lbs	750 lbs	750 lbs	750 lbs
Platform or Fork W x L	Platform 20" X 16"	Platform 22" x 22"	Platform 30" x 22"	Fork 3" x 18"	Fork 3" x 18"	Platform 20" x 16"	Platform 22" x 22"	Platform 30" x 22"	Fork 3" x 18"	Fork 3" x 18"
Lift Height	40"	54"	54"	40"	54"	40"	54"	54"	40"	54"
Load Center	10"	10"	10"	10"	10"	10"	10"	10"	10"	10"
Weight	106 lbs	147 lbs	157 lbs	125 lbs	157 lbs	113 lbs	153 lbs	163 lbs	132 lbs	163 lbs



Two Wheeled Hydraulic Models

- 1-year warranty.
- WESCO manufactured hydraulic Pedalift Jack, over 40 years of proven quality.
- Front tip of nose plate touches floor.
- Foot operated hydraulic pump raises platform, foot release lowers platform.
- Wheel lock standard.
- All 54" lifts are 60.5" O.A.H.
All 40" lifts are 48.5" O.A.H.
- 8" x 2" wheels with .75" precision ball bearings.
- Adjustable forks.



Four Wheeled Hydraulic Models

- 1-year warranty.
- WESCO manufactured hydraulic Pedalift Jack, over 40 years of proven quality.
- Available 304 stainless steel construction:
 - Stainless model has 8" x 2" polyurethane tread on polypropylene hub, non-marking wheels with 440 stainless sealed 3/4" precision ball bearing.
 - 304 stainless hydraulic jack.
 - 304 stainless swivel casters with plain bore 3.5" hard rubber wheels.
- Foot operated hydraulic pump raises platform, foot release lowers platform.
- Platform sits 5.75" above the floor.
- Wheel lock standard.
- All 54" lifts are 60.5" O.A.H. All 40" lifts are 48.5" O.A.H.
- 8" x 2" wheels with .75" precision ball bearings on steel models.
- 3.5" diameter polyurethane ball bearing front swivel caster on steel models.
- Adjustable forks.

OVERALL DIMENSIONS

w:	22.5"	22.5"	30"	22.5"	22.5"
h:	48.5"	60.5"	60.5"	48.5"	60.5"
d:	32"	32"	32"	32"	32"

OVERALL DIMENSIONS

w:	22.5"	22.5"	30"	22.5"	22.5"
h:	48.5"	60.5"	60.5"	48.5"	60.5"
d:	32"	32"	32"	32"	32"

304 Stainless Steel

22.5"	22.5"
60.5"	60.5"
32"	32"

Part # Model #	260001 PL-40-1620	260002 PL-54-2222	260003 PL-54-2230	260006 PL-40-F	260007 PL-54-F	260008 DPL-40-1620	260009 DPL-54-2222	260010 DPL-54-2230	260011 DPL-40-F	260012 DPL-54-F	260186 SSDPL-54-2222	260197 SSDPL-54-F
Capacity	750 lbs	750 lbs	750 lbs	750 lbs	750 lbs	750 lbs	750 lbs	750 lbs	750 lbs	750 lbs	750 lbs	750 lbs
Platform or Fork W x L	Platform 20" x 16"	Platform 22" x 22"	Platform 30" x 22"	Fork 3" x 18"	Fork 3" x 18"	Platform 20" X 16"	Platform 22" x 22"	Platform 30" x 22"	Fork 3" x 18"	Fork 3" x 18"	Platform 22" x 22"	Fork 3" x 18"
Lift Height	40"	54"	54"	40"	54"	40"	54"	54"	40"	54"	54"	54"
Load Center	10"	10"	10"	10"	10"	10"	10"	10"	10"	10"	10"	10"
Weight	112 lbs	156 lbs	166 lbs	131 lbs	166 lbs	119 lbs	166 lbs	172 lbs	138 lbs	172 lbs	175 lbs	181 lbs

CYLINDER TRUCK?

See page 30.



LLHPB

LLWPB



Hydraulic Cylinder Lift

- 1-year warranty.
- WESCO manufactured hydraulic Pedalift Jack, over 40 years of proven quality.
- Easily lifts and transports gas cylinders.
- Swivel casters make maneuvering in tight places easier.
- Two models:
 - Foot operated hydraulic pump.
 - Manual winch with auto-brake.
- Maximum cylinder diameter 9.5".
- Casters with wheel locks.

OVERALL DIMENSIONS

w: 20"	20"
h: 54"	58"
d: 29.25"	29.25"



Universal Lift

- 1-year warranty.
- Two straps with buckles to help secure load, 9' wrap around and 5' front to back.
- Manual winch with auto brake.
- Two 8" wheels and two 3 1/2" polyurethane casters.
- Lowered platform sits 6" above ground.
- Ideal for placing rental equipment on to pickup truck or into van.

OVERALL DIMENSIONS

w: 29.25"
h: 61"
d: 46.4"



LLHP



LLHF



Hydraulic Lite-Lift

- 1-year warranty.
- WESCO manufactured hydraulic Pedalift Jack, over 40 years of proven quality.
- Foot operated hydraulic pump.
- Release foot pedal for controlled lowering.
- Casters with wheel locks.
- Adjustable forks.

OVERALL DIMENSIONS

w: 20"	20"
h: 70.5"	70.5"
d: 30"	30"

Platform Option

- Provides the utility of two units.
- Easy installation - no tools required.

Part # - 260157
Model # - POK

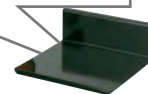

To order option, add Part # or Model # to Lite-Lift Part # or Model #.



LLWP



Winch Lite-Lift

- 1-year warranty.
- Manual winch with auto-brake.
- No catches to release.
- Low maintenance.
- Casters with wheel locks.

OVERALL DIMENSIONS

w: 20"	20"
h: 70.5"	70.5"
d: 30"	30"

Part # Model #	260161 LLHPB	260163 LLWPB	260130 ULP2630	260150 LLHP	260151 LLHF	260152 LLWP	260153 LLWF
Capacity	300 lbs	300 lbs	750 lbs	500 lbs	500 lbs	500 lbs	500 lbs
Platform or Fork W x L	Platform 12" x 20"	Platform 12" x 20"	Platform 26" x 30"	Platform 20" x 20"	Fork 3" x 19" x .75"	Platform 20" x 20"	Fork 3" x 19" x .75"
Lift Height	40" / Hydraulic	40" / Winch	54"	54"	54"	54"	54"
Lowered Height	1/4"	1/4"	6"	5.75"	4.25"	5.75"	4.25"
Caster / Wheel Size	5"	5"	3.5" / 8"	5"	5"	5"	5"
Front Leg Span	N/A	N/A	N/A 19.75" OD	15.25" ID x 20" OD	15.25" ID 20" OD	15.25" ID 20" OD	15.25" ID 20" OD
Load Center	10"	10"	6"	10"	10"	10"	10"
Weight	165 lbs	152 lbs	224 lbs	139 lbs	157 lbs	103 lbs	124 lb



261160 Frame w/
261161 Drum Lifter



261160 Frame w/
261162 Adjustable Forks



261160 Frame w/
261163 Platform



Aluminum Frame Pedalifts Features:

- Aluminum construction for lightweight ruggedness.
- 20" deep x 22" wide platform size.
- Wheel locks are standard on all models.
- Front of platform touches the floor.
- Frame and lift heights vary among models.

Triple Truck

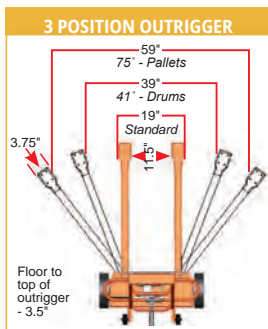

- 1-year warranty, Patent NO. US9,139,214B2.
- Handles most standard rim 30, 55 and 85 gal. steel, poly and fiber drums.
- Manual winch with auto brake.
- Carriage lock, lock carriage in place at any position.
- Easy load rollers assist loading onto a truck bed.
- Low-profile 3" debris deflecting neoprene swivel casters.
- Floor to top of leg height - 3.75".
- 10" x 2.75" poly hub solid rubber wheels - Part # 150698.
- Wheel lock - pedal activated.
- Lever operated outrigger adjustment - 3 positions.
- Outrigger angle can be changed even under full load.

3 Models of Lifting Attachments - No tools required:

- #261161 - Gator Grip® Drum Lifter Attachment
- #261162 - Adjustable Width Forks -6" to 19½" O.D.
- #261163 - Platform - 21¼" W x 28½" D.
(Optional slip-on over forks.) Requires adjustable fork option.

HOW TO ORDER:

- Frame and attachments ordered separately.
1. Purchase basic frame - Part #261160.
 2. Select lifting attachment.
 - a. Gator Grip® Drum Lifter - Part #261161.
 - b. Adjustable Forks - Part #261162.
 - c. Slip-on Platform* - Part #261163. *(Requires adjustable fork option.)*



WMPL-54-2022
Winch/Platform



MPL-54-2022
Hydraulic/Platform

Two Wheeled Winch Models



- 1-year warranty.
- Manual winch with auto-brake.
- Light weight minimizes the effort required for moving and lifting.
- Wheel lock standard.
- 8"x2" wheels with .75" ball bearings.

Two Wheeled Hydraulic Models



- 1-year warranty.
- Foot operated hydraulic pump raises platform, foot release lowers platform.
- WESCO manufactured hydraulic Pedalift Jack, over 40 years of proven quality.
- Wheel lock standard.
- 8"x2" wheels with .75" ball bearings.

OVERALL DIMENSIONS

w: 30"	16"
h: 70.75"	33"
d: 52.25"	12"

OVERALL DIMENSIONS

w: 22.5"	w: 22.5"
h: 48.5"	h: 60.5"
d: 32"	d: 32"

OVERALL DIMENSIONS

w: 22.5"	w: 22.5"
h: 48.5"	h: 60.5"
d: 32"	d: 32"

Part # Model #	261160 TTF	261161 TTF-GG	261162 TTF-AF	261163 TTF-P	260025 WMPL-40-2022	260026 WMPL-54-2022	260004 MPL-40-2022	260005 MPL-54-2022
Capacity	750 lbs	750 lbs	750 lbs	750 lbs	400 lbs	400 lbs	400 lbs	400 lbs
Platform or Fork W x L	FRAME ONLY	GATOR GRIP	ADJ. FORKS 3" x 26.75"	PLATFORM* 21.25" x 28.125"	Platform 22" x 20"	Platform 22" x 20"	Platform 22" x 20"	Platform 22" x 20"
Front Leg Span	SEE CHART ABOVE				N/A	N/A	N/A	N/A
Lift Height	N/A	69"	62"	62.125"	40"	54"	40"	54"
Caster / Wheel Size	3" / 10"	N/A	N/A	N/A	8" x 2"	8" x 2"	8" x 2"	8" x 2"
Load Center	N/A	16"	16"	16"	10"	10"	10"	10"
Weight	224 lbs	32 lbs	30 lbs	6 lbs	61 lbs	68 lbs	71 lbs	77 lbs



273510
Fixed Base
(Forks Down)



273510
Fixed Base
(Forks Up)

Optional Removable Steel Platform

- Fits over forks.
- Size: 20.5"W x 24.25"L.
- Weight: 26 lbs.
- Part #273518

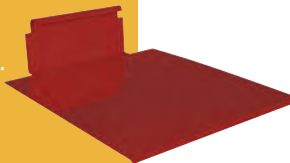

273516
Counter-balance Straddle
(Forks Down)



273513
Adjustable Straddle
(Forks Down)



With optional support backrest and foldable platform.



Premium Light Duty Winch Lift

- 1 Year Warranty on parts only.
- Zinc-plated finish.
- Suitable for clean environments.
- Swivel caster, 3/4" polyurethane dual wheel .
- Easy maneuvering in tight or narrow spaces.
- 2" lifting strap.
- Manual winch with auto brake.
- Optional zinc-plated cargo support backrest. Part #274531.
- Optional 304 stainless steel foldable platform- 15.125" x 23.25" - Part #274530.

Hand Winch Lifters

- Capacities: 350, 400 and 500 lbs.
- Aluminum and steel construction.
- 8" rear wheels and 2" front swivel casters are non-marking.
- Forks can be inverted for two different lift heights. Fork size: 4"W x 22.5"L x 1.75"H.
- Winch crank handle locks to secure carriage.
- Three models:
Fixed Base used in narrow work spaces. Base legs: 13" inside width x 21.5" overall width.
Adjustable Straddle with adjustable legs 21.5" to 36" inside width and 29" to 44" outside width.
Counter-balance Straddle. Short legs get you close to load when there is no room for standard legs. 5" polyurethane rear swivel casters with brakes and 4" front wheels.
- Top of frame rollers facilitates laying truck horizontal for transport.

OVERALL DIMENSIONS

w:	24"	24"	29"	29"	29"	29"	29"	29"	29"
h:	68"	68"	79"	68"	68"	68"	68"	68"	68"
d:	35"	35"	43"	43"	43"	47"	47"	47"	47"

OVERALL DIMENSIONS

w:	23.25"
h:	54.125"
d:	29.25"

Part # Model #	273510 HWLFX-4	273511 HWLFX-5	273512 HWLSD-3.5	273513 HWLSD-4	273514 HWLSD-5	273515 HWLCB-3.5	273516 HWLCB-4	273517 HWLCB-5	274520 DWL-43
Capacity	400 lbs	500 lbs	350 lbs	400 lbs	500 lbs	350 lbs	400 lbs	500 lbs	265 lbs
Base	Fixed	Fixed	Adjustable Straddle	Adjustable Straddle	Adjustable Straddle	Counter-balance Straddle	Counter-balance Straddle	Counter-balance Straddle	<i>Fork Dimension 1.375" Dia. x 15"</i>
Max. Lift Range*	98" / 120"	47" / 70"	120" / 142"	98" / 120"	47" / 70"	120" / 142"	98" / 120"	47" / 70"	43"
Lowered Height Range*	3.5" / 25"	3.5" / 27.5"	1.25" / 21.5"	1.25" / 21.5"	1.25" / 21.5"	1.25" / 21.5"	2" / 25"	2" / 25"	3.25"
Load Center	11.25"	11.25"	11.25"	11.25"	11.25"	11.25"	11.25"	11.25"	15.25"
Weight	154 lbs	143 lbs	176 lbs	165 lbs	154 lbs	405 lbs	394 lbs	383 lbs	55 lbs

Aluminum Frame Pedalifts Feature:

- Floor locks, safety screen and foot guard are standard on all models.
- Forks touch the floor on all fork models.
- Front phenolic wheels are 5" diameter.
- Rear phenolic swivel casters are 4" diameter.
- **Hydraulic jack manufactured by WESCO.**
- "S"tandard line features one piece platform guide rail.
- "E"conomy line offers an economical price value.
- Foot pedal - pump and release.



SPL-60-2424



ESPL-60-2424

Wesco Platform Models



- 1-year warranty.
- WESCO manufactured hydraulic Stacker Jack, over 40 years of proven quality.
- 24" x 24" heavy gauge platform with 5.75" lowered height.
- 15" load center.
- Base leg span - 15" inside, 21" outside.
- **NEW** Low Profile Outrigger Option available.

Wesco Large Platform Models



- 1-year warranty.
- WESCO manufactured hydraulic Stacker Jack, over 40 years of proven quality.
- 30" deep x 32" wide heavy gauge platform with 5.25" lowered height.
- 18" load center.
- Base leg span - 25.5" inside, 32" outside.
- **NEW** Low Profile Outrigger Option available. See below.



SPL-80-3032



ESPL-60-3032

OVERALL DIMENSIONS

w: 25.5"	25.5"	25.5"	25.5"	25.5"	25.5"
h: 75"	72"	83"	80"	94"	92"
d: 40"	40"	38"	40"	40"	40"

Standard Economy Standard Economy Standard Economy

OVERALL DIMENSIONS

w: 32"	32"	32"	32"	32"	32"
h: 75"	72"	83"	80"	94"	92"
d: 44.5"	44.5"	44.5"	44.5"	44.5"	44.5"

Standard Economy Standard Economy Standard Economy

Part #	260032	260044	260033	260045	260034	260046	260038	260050	260039	260051	260040	260052
Model #	SPL-60-2424	ESPL-60-2424	SPL-68-2424	ESPL-68-2424	SPL-80-2424	ESPL-80-2424	SPL-60-3032	ESPL-60-3032	SPL-68-3032	ESPL-68-3032	SPL-80-3032	ESPL-80-3032
Capacity	1,000 lbs	1,000 lbs	1,000 lbs	1,000 lbs	1,000 lbs	1,000 lbs	1,000 lbs	1,000 lbs	1,000 lbs	1,000 lbs	1,000 lbs	1,000 lbs
Platform/Fork W x L	24" x 24"	24" x 24"	24" x 24"	24" x 24"	24" x 24"	24" x 24"	32" x 30"	32" x 30"	32" x 30"	32" x 30"	32" x 30"	32" x 30"
Lift Height	60"	60"	68"	68"	80"	80"	60"	60"	68"	68"	80"	80"
Load Center	15"	15"	15"	15"	15"	15"	18"	18"	18"	18"	18"	18"
Weight	233 lbs	226 lbs	248 lbs	234 lbs	274 lbs	263 lbs	272 lbs	265 lbs	295 lbs	273 lbs	317 lbs	298 lbs
Low Profile Option	Yes	Yes	Yes	Yes	Yes	Yes	Yes	Yes	Yes	Yes	Yes	Yes

1,000 lb Capacity Winch Stacker

- 1-year warranty.
- Heavy duty 1,000 lb capacity.
- Heavy duty winch with auto brake.
- Floor lock and safety screen are standard.
- Swivel casters - 4" x 2" phenolic. Load wheels - 5" x 2" phenolic.
- Lowered height - 5.25".
- **NEW** Low Profile Outrigger Option available.



SWPL-68-2424

OVERALL DIMENSIONS

w: 24"
h: 83.25"
d: 41"

Part #	270214
Model #	SWPL-68-2424
Capacity	1,000 lbs
Lift Height	70"
Load Center	15"
Weight	238 lbs
Low Profile Option	Yes

Low Profile Outrigger Option

- Available only on fixed base, platform, fork, hydraulic or winch 1,000 lb. capacity stackers.
- Standard stacker outrigger height - 5 1/2".
- Optional low profile height - 2 1/2".
- To order add "LP" to stacker Part #. Example: 260032-LP.

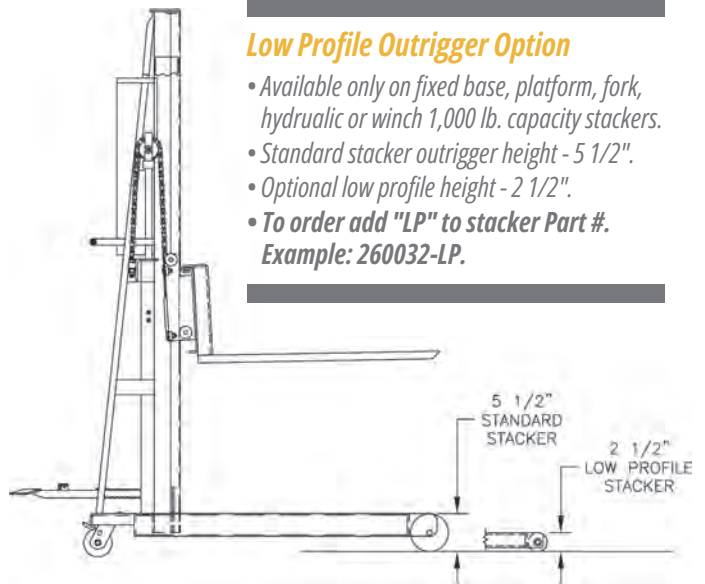

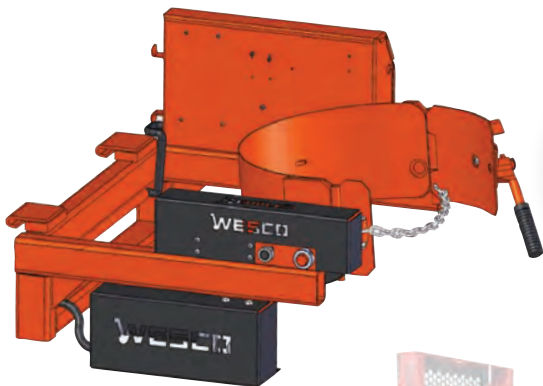

Power Drum Rotator
Part #240145

STACKER NOT INCLUDED



Manual Drum Rotator
Part #240144

STACKER NOT INCLUDED

Wesco Power Drum Rotator

- Fully self-contained
- No stacker modifications required
- Wireless remote control for safe operation
- Heavy duty battery for extended operation
- On-board charger
- Industrial gear motor drive
- Handles 55 gallon, 30 gallon and fiber drums (w/attachments)
- Ships assembled and boxed
- Capacity: 800 lbs./full drum
500 lbs./half drum
- For use with Wesco Counterbalance Stackers and Fork Model Stackers (with 25" or greater ID outrigger span)

OVERALL DIMENSIONS

w: 35"
h: 20.75"
d: 30.5"

Wesco Manual Drum Rotator

- Manual geared tilting configuration that allows for full drum rotational control using a traditional chain (144" length) and wheel design.
- Geared design allows controlled dumping and dispensing
- 30:1 gear ratio
- Removable tilt handle
- For use with Wesco Counterbalance Stackers and Fork Model Stackers (with 25" or greater ID outrigger span)

OVERALL DIMENSIONS

w: 35"
h: 15"
d: 30.5"

Part #	240145	240144
Model #	PDRA-55-1K	DRA-55-1K
Capacity	800 lb/full drum - 500 lb/half drum	800 lb/full drum - 500 lb/half drum
Weight	150 lbs	118 lbs

Options



DMG-30A - 30 Gallon Insert
Part# 270040



FBA - Fiber Drum Adapter
Part# 270402

Wesco Fork Model 

- 1-year warranty.
- 1" thick x 3" wide x 25" long forks.
- Adjustable fork range:
minimum - 6.125" O.D.
maximum - 25" O.D.
- 15" load center.
- 25.5" overall width; 40" depth.
- Base leg span - 15" inside, 21" outside.
- Forks lower to ground.
- **WESCO manufactured hydraulic Stacker Jack, over 40 years of proven quality.**
- **NEW** Low Profile Outrigger Option available. (See page 64.)



OVERALL DIMENSIONS

w:	25.5"	25.5"	25.5"	25.5"	25.5"	25.5"
h:	75"	72"	83"	80"	94"	92"
d:	44.5"	44"	44.5"	44"	44.5"	44"

	Standard	Economy	Standard	Economy	Standard	Economy
Part #	260035	260047	260036	260048	260037	260049
Model #	SFL-56-25	ESFL-56-25	SFL-64-25	ESFL-64-25	SFL-76-25	ESFL-76-25
Capacity	1,000 lbs	1,000 lbs	1,000 lbs	1,000 lbs	1,000 lbs	1,000 lbs
Platform/Fork W x L	3" x 25"	3" x 25"	3" x 25"	3" x 25"	3" x 25"	3" x 25"
Lift Height	56"	56"	64"	64"	76"	76"
Load Center	15"	15"	15"	15"	15"	15"
Weight	265 lbs	258 lbs	273 lbs	266 lbs	306 lbs	295 lbs
Low Profile Option	Yes	Yes	Yes	Yes	Yes	Yes

Straddle Fork Model 

- 1-year warranty.
- 1" thick x 3" wide x 30" long forks.
- Adjustable fork range:
minimum - 6.125" O.D.
maximum - 25" O.D.
- 18" load center.
- 32" overall width; 44" depth.
- Base leg span - 25.5" inside, 32" outside.
- Forks lower to ground.
- **WESCO manufactured hydraulic Stacker Jack, over 40 years of proven quality.**
- **NEW** Low Profile Outrigger Option available. (See page 64.)

SFL-64-30S



Wide Straddle Fork Model 

- 1-year warranty.
- 1" thick x 3" wide x 30" long forks.
- Base leg span - 42" inside, 48.75" outside.
- Adjustable fork range:
minimum - 6.125" O.D.
maximum - 25" O.D.
- Overall width 48.75", depth 48.25".
- Forks lower to the ground.
- NOT AVAILABLE - Low profile option.
- **WESCO manufactured hydraulic Stacker Jack, over 40 years of proven quality.**

ESFL-56-30-42S



OVERALL DIMENSIONS

w:	32.5"	32.5"	32.5"	32.5"	32.5"	32.5"	48.5"
h:	75"	72"	83"	80"	94"	92"	72.5"
d:	48"	48"	48"	48"	48"	48"	49"

	Standard	Economy	Standard	Economy	Standard	Economy	Wide
Part #	260041	260053	260042	260054	260043	260055	260075
Model #	SFL-56-30S	ESFL-56-30S	SFL-64-30S	ESFL-64-30S	SFL-76-30S	ESFL-76-30S	ESFL-56-30-42S
Capacity	1,000 lbs	1,000 lbs	1,000 lbs	1,000 lbs	1,000 lbs	1,000 lbs	1,000 lbs
Fork W x L	3" x 30"	3" x 30"	3" x 30"	3" x 30"	3" x 30"	3" x 30"	3" x 30"
Lift Height	56"	56"	64"	64"	76"	76"	56"
Load Center	18"	18"	18"	18"	18"	18"	18"
Weight	288 lbs	281 lbs	298 lbs	289 lbs	333 lbs	322 lbs	352 lbs
Low Profile Option	Yes	Yes	Yes	Yes	Yes	Yes	No

Adjustable Fork Model 272940

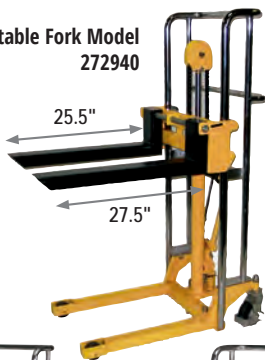

Chrome plated platform is an option.

With optional platform #272942

Value Lift

- Adjustable 4" wide x 25.5" long forks.
- Optional, removable chrome plated 22" wide x 26" long platform.
- Foot operated hydraulic pump.
- Two 5" polyurethane swivel casters with brake and two 3" polyurethane rigid wheels.
- Two lift heights: 47" and 59".
- Chrome plated rails and handle.
- Ships KD.
- **#272942 Optional Platform fits both Manual and Electric Value Lift Stackers.**

OVERALL DIMENSIONS

w: 22.5"	22.5"	22"
h: 55"	70"	1"
d: 36"	37"	26"



Control Panel



VLP-59

Electric Value Lift Stackers

- Adjustable 4" wide x 25.5" long forks.
- Optional, removable 22" wide x 26" long platform.
- Two 5" polyurethane swivel casters with brake and two 3" polyurethane rigid wheels.
- Two lift heights: 47" and 59".
- Chrome plated rails and handles.
- UL approved charger.
- Sealed maintenance-free battery.
- Keyed on/off switch.
- Raise/lower controls.
- **#272942 Optional Platform fits both Manual and Electric Value Lift Stackers.**

OVERALL DIMENSIONS

w: 22.5"	22.5"
h: 55"	68"
d: 44"	44"



MOL



EOL

Manual and Electric Office Lifts

- Ideal for narrow aisles.
- Great for offices.
- Two models, manual and electric.
- Lightweight, but sturdy.
- Sealed battery and automatic charger built in.
- Remote up and down pendant for electric model.
- 9/16" thick plastic platform.

OVERALL DIMENSIONS

w: 23.5"	23.5"
h: 71.5"	78"
d: 32"	34"

OPTIONS FOR OFFICE LIFTS



Single Spindle Model EP05-01
Part #274654
Double Spindle Model EP06-01
Part #274655
Roll raw material picking



Bin Clamp Model EP08-01
Part #274657
Plastic bin picking



Roller Platform Model EP02-01
Part #274651
Stainless steel rollers make transport smooth, easy clean up

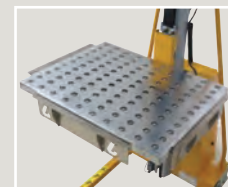

Stainless Ball Transfer Model EP01-01
Part #274650
Smoothly operating from 3 directions on/off the platform



V Block Model EP03-01
Part #274652
V block shape specially for roll material transport

Part # Model #	Value Lift			Electric Value Lift Stackers		Manual and Electric Office Lifts	
	Value Lift	Value Lift	Optional Platform	Manual	Electric	Manual	Electric
272940 VL47	272941 VL59	272942 VLRP	273203 VLP-47	273204 VLP-59	272467 MOL	272468 EOL	
Capacity	880 lbs	880 lbs	N/A	880 lbs	880 lbs	220 lbs	220 lbs
Platform or Fork W x L	Fork 4" x 25.5"	Fork 4" x 25.5"	Platform 22" x 26"	Fork 4" x 25.5"	Fork 4" x 25.5"	Platform 18" x 23"	Platform 18" x 23"
Lift Height	3.5" - 47"	3.5" - 59"	N/A	3.5" - 47"	3.5" - 59"	58.5"	66"
Lowered Height	3.5"	3.5"	N/A	3.5"	3.5"	5"	5"
Adj. Fork Width	8.5" - 19.5"	8.5" - 19.5"	N/A	8.25" - 21.5"	8.25" - 21.5"	N/A	N/A
Swivel Casters	5" Locking Polyurethane	5" Locking Polyurethane	N/A	5" Locking Polyurethane	5" Locking Polyurethane	5" x 1.25" Hard Rubber	5" x 1.25" Hard Rubber
Load Wheels	3" Rigid Polyurethane	3" Rigid Polyurethane	N/A	3" Rigid Polyurethane	3" Rigid Polyurethane	2.75" x 1.25" Hard Rubber	2.75" x 1.25" Hard Rubber
Battery	N/A	N/A	N/A	12V 80AH	12V 80AH	N/A	12V
Load Center	12.75"	12.75"	N/A	12.75"	12.75"	9.25"	9.25"
Weight	178 lbs	187 lbs	10 lbs	269 lbs	280 lbs	104 lbs	146 lbs

Power And Manual Drum Rotator Attachments
Page 65



Manual Drum Rotator
Part #240144



2,200 lb Capacity Power Drive Stacker

- 6 Month Warranty on parts only.
- Can not be used with pallets - only skids without bottom slates.
- Lift height of 98¼". Dual chain lift.
- Includes two, 12 volt, 187 AH, sealed batteries and a separate UL approved charger.
- Power propulsion system takes the effort out of moving heavy loads. Also provides easy steering.
- Fingertip control provides variable forward and reverse speeds.
- Automatic safety stop on top of control post. Unit shuts down when safety stop comes into contact with an obstacle.
- Load wheels, steering wheel and drive wheel are all moldon polyurethane.
- Adjustable forks.

OVERALL DIMENSIONS

w: 35"
h: 70" - 117.5"
d: 64"

Part # Model	272943 EKS-10
Capacity	2,200 lbs
Lowered Mast Height	70"
Raised Mast Height	117.5"
Leg ID/OD	19" / 27"
Fork Size W x L	5" x 35.25"
Outside Fork Spread	12" - 29" - Adjustable
Lowered Fork Height	2.6"
Raised Fork Height	98.25"
Load Center	17.5"
Weight	826 lbs

Features of Counter-Balance Powered Line of Stackers

- Meets ANSI B56.10 specifications.
- Maximum lift capacity - 1,000 lbs.
- Remote control, floor lock, and safety screen are standard on all models.
- With a minimally charged battery, unit can be used while recharging.
- Easy to read illuminated battery status voltmeter - no extra cost!



Standard features include:
remote control
voltmeter
on/off switch.

Counter-Balance Powered Stacker

- 1-year warranty.
- Proven quality: WESCO manufactured Hydraulic Cylinder.
- Battery and charger included.
- Applications include:
 - Loading and unloading trucks.
 - Positioning dies.
 - Feeding material to presses.
- 25" long forks standard.
- 30" long fork models available, 850 lb. max. capacity.
- Order enough weight kits for your planned load. (See chart below.)
- AC models not available.



261039

Note: Counter-Balance Stackers require appropriate counter-weights. See chart below.

OVERALL DIMENSIONS

w: 26.5" 26.5" 26.5"
h: 75" 83" 94"
d: 59.5" 59.5" 59.5"

Part # Model #	261037 PCBFL-56-25	261038 PCBFL-64-25	261039 PCBFL-76-25
Capacity	1,000 lbs	1,000 lbs	1,000 lbs
Fork W x L	3" x 25"	3" x 25"	3" x 25"
Outside Fork Spread	6" - 25" - Adjustable	6" - 25" - Adjustable	6" - 25" - Adjustable
Lift Height	56"	64"	76"
Wheel: Front	5"	5"	5"
Wheel: Rear	5"	5"	5"
Load Center	13"	13"	13"
Weight*	560 lbs	574 lbs	611 lbs

*Weight of stacker without counterweights.

COUNTER-BALANCE WEIGHTS

Part #	261041	261042	261043
Counterweight	200 lbs	400 lbs	600 lbs
Stacker Load Capacity	334 lbs	668 lbs	1,000 lbs



Platform Model

- 1-year warranty.
- Proven quality: WESCO manufactured Hydraulic Cylinder.
- Battery and charger included.
- Lowered height 5.75"
- Phenolic wheels on front and phenolic casters on rear.
- Power Drive Option available: see page 71 for details. Add "-PD" to end of Part #.
- **110V AC models available (Special Order). Add AC to end of Part #.**
- **NEW** Low Profile Outrigger Option available.

261024



Fork Model

- 1-year warranty.
- Proven quality: WESCO manufactured Hydraulic Cylinder.
- Battery and charger included.
- Forks lower to floor on all models.
- 5" phenolic wheels on front, 4" swivel on rear.
- Power Drive Option available: see page 71 for details. Add "-PD" to end of Part #.
- **110V AC models available (Special Order). Add AC to end of Part #.**
- Adjustable fork range: minimum - 6" O.D. maximum - 25" O.D.
- **NEW** Low Profile Outrigger Option available.

261033



Adjustable Span Straddle Model

- 1-year warranty.
- Proven quality: WESCO manufactured Hydraulic Cylinder.
- Battery and charger included.
- Forks lower to floor on all models.
- Extra deep (40") straddle legs and forks for lifting pallets.
- Versatile adjustable span straddle legs can be set from 34" to 50" inside dimension to handle most standard pallets.
- Power Drive Option available: see page 71 for details.
- **110V AC models available (Special Order). Add AC to end of Part #.**
- Adjustable fork range: minimum - 6" O.D., maximum - 25" O.D.
- Low Profile Option not available.

261035



OVERALL DIMENSIONS

w: 25.5"	25.5"	25.5"
h: 72"	80"	92"
d: 36"	36"	36"

OVERALL DIMENSIONS

w: 25.5"	25.5"	25.5"
h: 72"	80"	92"
d: 44.5"	44.5"	44.5"

OVERALL DIMENSIONS

w: 54" Max	54" Max	54" Max
h: 72"	80"	92"
d: 58.75"	58.75"	58.75"

24" x 24" Platform Models

Fork Models

Adjustable Straddle Fork Models

Part # Model #	261022 PESPL-60-2424	261023 PESPL-68-2424	261024 PESPL-80-2424	261028 PESFL-56-25	261029 PESFL-64-25	261030 PESFL-76-25	261034 PASFL-56-40S	261035 PASFL-64-40S	261036 PASFL-76-40S
Capacity	1,000 lbs	1,000 lbs	1,000 lbs	1,000 lbs	1,000 lbs	1,000 lbs	1,000 lbs	1,000 lbs	1,000 lbs
Platform or Fork W x L	Platform 24" x 24"	Platform 24" x 24"	Platform 24" x 24"	Fork 3" x 25"	Fork 3" x 25"	Fork 3" x 25"	Fork 3" x 40"	Fork 3" x 40"	Fork 3" x 40"
Lift Height	60"	68"	80"	56"	64"	76"	56"	64"	76"
Leg ID/OD	15"/21"	15"/21"	15"/21"	15"/21"	15"/21"	15"/21"	34" to 50" ID Adj.	34" to 50" ID Adj.	34" to 50" ID Adj.
Wheel: Front Rear	5" phenolic 4" phenolic swivel	5" phenolic 4" phenolic swivel	5" phenolic 4" phenolic swivel	5" phenolic 4" phenolic swivel	5" phenolic 4" phenolic swivel	5" phenolic 4" phenolic swivel	5" phenolic 4" phenolic swivel	5" phenolic 4" phenolic swivel	5" phenolic 4" phenolic swivel
Load Center	15"	15"	15"	15"	15"	15"	20"	20"	20"
Weight	418 lbs	428 lbs	457 lbs	452 lbs	460 lbs	489 lbs	510 lbs	518 lbs	554 lbs
Low Profile Option	Yes	Yes	Yes	Yes	Yes	Yes	No	No	No

30" x 32" Platform Models

Straddle Fork Models

Part # Model #	261025 PESPL-60-3032	261026 PESPL-68-3032	261027 PESPL-80-3032	261031 PESFL-56-30S	261032 PESFL-64-30S	261033 PESFL-76-30S
Capacity	1,000 lbs	1,000 lbs	1,000 lbs	1,000 lbs	1,000 lbs	1,000 lbs
Platform or Fork W x L	Platform 32" x 30"	Platform 32" x 30"	Platform 32" x 30"	Fork 3" x 30"	Fork 3" x 30"	Fork 3" x 30"
Lift Height	60"	68"	80"	56"	64"	76"
Leg ID/OD	25.5" / 32"	25.5" / 32"	25.5" / 32"	25.5"/32"	25.5"/32"	25.5"/32"
Wheel: Front Rear	5" rigid 4" swivel	5" rigid 4" swivel	5" rigid 4" swivel	5" phenolic 4" swivel	5" phenolic 4" swivel	5" phenolic 4" swivel
Load Center	18"	18"	18"	18"	18"	18"
Weight	404 lbs	427 lbs	452 lbs	442 lbs	456 lbs	465 lbs
Low Profile Option	Yes	Yes	Yes	No	No	No

Low Profile Outrigger Option

• Available only on fixed base, platform, fork, hydraulic or winch, 1,000 lb. capacity stackers.

- Standard stacker outrigger height - 5 1/2".
- Optional low profile height - 2 1/2".
- To order add "LP" to stacker Part #. (Example: 260032-LP).

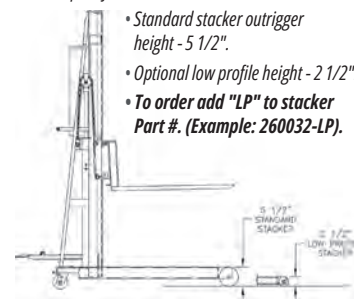



261053

1,500 & 2,000 lb Capacity Powered Stackers - Fork Models

- 1-year warranty.
- Proven quality: WESCO manufactured Hydraulic Cylinder.
- Meets ANSI B56.10 specifications.
- Battery and charger included.
- Adjustable forks:
 - Lower to floor on all models.
 - 3" wide x 25", 30" and 42" long.
 - OD adjustment from 6" to 24.5" or 29" maximum width.
- Adjustable base legs available on fork models.
- Reinforced frame and base.
- Double chain, lift support.
- Heavy-duty pump.
- Ergonomic "D" handles.
- 5th wheel option see page below.
- Power Drive Option available: see page 71 for details. Add "-PD" to end of Part #.



30 Fixed and 6 Adjustable Base Leg Fork Models

Part #	Model #	Lift Height	Overall Height	Weight lbs	Capacity lbs	Load Center	Fork Width/Length	Base Leg ID/OD	Adj. Fork Min./Max. OD
261079	PSFL-56-25-15S-1.5K	56"	72"	512	1,500	15"	3"/25"	15"/21"	6" / 24.5"
261080	PSFL-64-25-15S-1.5K	64"	83"	532	1,500	15"	3"/25"	15"/21"	6" / 24.5"
261081	PSFL-76-25-15S-1.5K	76"	94"	596	1,500	15"	3"/25"	15"/21"	6" / 24.5"
261082	PSFL-86-25-15S-1.5K	86"	104"	642	1,500	15"	3"/25"	15"/21"	6" / 24.5"
261083	PSFL-56-25-20S-1.5K	56"	72"	523	1,500	15"	3"/25"	20"/26"	6" / 24.5"
261084	PSFL-64-25-20S-1.5K	64"	83"	543	1,500	15"	3"/25"	20"/26"	6" / 24.5"
261085	PSFL-76-25-20S-1.5K	76"	94"	607	1,500	15"	3"/25"	20"/26"	6" / 24.5"
261086	PSFL-86-25-20S-1.5K	86"	104"	654	1,500	15"	3"/25"	20"/26"	6" / 24.5"
261092	PSFL-56-25-20S-2K	56"	72"	523	2,000	15"	3"/25"	20"/26"	6" / 24.5"
261093	PSFL-64-25-20S-2K	64"	83"	558	2,000	15"	3"/25"	20"/26"	6" / 24.5"
261094	PSFL-76-25-20S-2K	76"	94"	611	2,000	15"	3"/25"	20"/26"	6" / 24.5"
261095	PSFL-86-25-20S-2K	86"	104"	659	2,000	15"	3"/25"	20"/26"	6" / 24.5"
261059	PSFL-64-30-30S-1.5K	64"	83"	566	1,500	18"	3"/30"	30"/36"	6" / 29"
261060	PSFL-76-30-30S-1.5K	76"	94"	630	1,500	18"	3"/30"	30"/36"	6" / 29"
261061	PSFL-86-30-30S-1.5K	86"	104"	677	1,500	18"	3"/30"	30"/36"	6" / 29"
261044	PSFL-64-30-30S-2K	64"	83"	571	2,000	18"	3"/30"	30"/36"	6" / 29"
261045	PSFL-76-30-30S-2K	76"	94"	635	2,000	18"	3"/30"	30"/36"	6" / 29"
261046	PSFL-86-30-30S-2K	86"	104"	682	2,000	18"	3"/30"	30"/36"	6" / 29"
261062	PSFL-64-42-42S-1.5K	64"	83"	571	1,500	24"	3"/42"	42"/48"	6" / 29"
261063	PSFL-76-42-42S-1.5K	76"	94"	637	1,500	24"	3"/42"	42"/48"	6" / 29"
261064	PSFL-86-42-42S-1.5K	86"	104"	688	1,500	24"	3"/42"	42"/48"	6" / 29"
261047	PSFL-64-42-42S-2K	64"	83"	577	2,000	24"	3"/42"	42"/48"	6" / 29"
261048	PSFL-76-42-42S-2K	76"	94"	642	2,000	24"	3"/42"	42"/48"	6" / 29"
261049	PSFL-86-42-42S-2K	86"	104"	693	2,000	24"	3"/42"	42"/48"	6" / 29"
261065	PSFL-64-42-50S-1.5K	64"	83"	577	1,500	24"	3"/42"	50"/56"	6" / 29"
261066	PSFL-76-42-50S-1.5K	76"	94"	642	1,500	24"	3"/42"	50"/56"	6" / 29"
261067	PSFL-86-42-50S-1.5K	86"	104"	693	1,500	24"	3"/42"	50"/56"	6" / 29"
261050	PSFL-64-42-50S-2K	64"	83"	582	2,000	24"	3"/42"	50"/56"	6" / 29"
261051	PSFL-76-42-50S-2K	76"	94"	647	2,000	24"	3"/42"	50"/56"	6" / 29"
261052	PSFL-86-42-50S-2K	86"	104"	698	2,000	24"	3"/42"	50"/56"	6" / 29"
261068	PASFL-64-42-3550S-1.5K	64"	83"	587	1,500	24"	3"/42"	35"-50" ID ADJ.	6" / 29"
261069	PASFL-76-42-3550S-1.5K	76"	94"	652	1,500	24"	3"/42"	35"-50" ID ADJ.	6" / 29"
261070	PASFL-86-42-3550S-1.5K	86"	104"	703	1,500	24"	3"/42"	35"-50" ID ADJ.	6" / 29"
261053	PASFL-64-42-3550S-2K	64"	83"	592	2,000	24"	3"/42"	35"-50" ID ADJ.	6" / 29"
261054	PASFL-76-42-3550S-2K	76"	94"	657	2,000	24"	3"/42"	35"-50" ID ADJ.	6" / 29"
261055	PASFL-86-42-3550S-2K	86"	104"	708	2,000	24"	3"/42"	35"-50" ID ADJ.	6" / 29"

5th Wheel Steering Option



5th Wheel Steering Option for easier mobility and precision steering in confined areas. Available only on 1,500 and 2,000 lb models. 8" locking polyurethane wheels. Spring loaded handle. Turning radius: 73.5". Can be field installed. **Order as separate option under Part # 261099.**

Adjustable Width Legs 6 Models





1,500 & 2,000 lb Capacity Powered Stackers - Platform Models

- 1-year warranty.
 - Proven quality: WESCO manufactured Hydraulic Cylinder.
 - Meets ANSI B56.10 specifications.
 - Battery and charger included.
 - Platform models lowered height 6".
 - Adjustable base legs available on fork models only.
 - Fixed platforms 24" x 24", 24" x 27", 30" x 32".
 - Reinforced frame and base.
 - Double chain, lift support.
 - Dual platform stacker #262056, call for details.
 - Heavy-duty pump.
 - Ergonomic "D" handles.
 - 5th wheel option see page 70.
 - Power Drive Option available: see below for details.
- Add "-PD" to end of Part #.

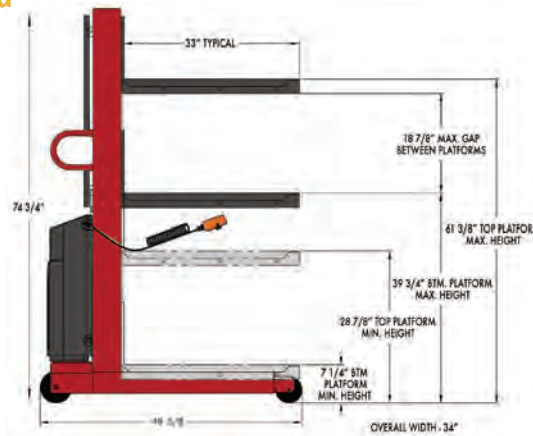

**TWO PLATFORMS!
DOUBLE PRODUCTION**

Fixed Base Leg Platform Models

Part #	Model #	Lift Height	Overall Height	Weight lbs	Capacity lbs	Load Center	Platform Width/Length	Base Leg ID/OD
261074	PSPL-60-2424-15S-1.5K	60"	72"	468	1,500	15"	24" x 24"	15"/21"
261075	PSPL-68-2424-15S-1.5K	68"	83"	482	1,500	15"	24" x 24"	15"/21"
261076	PSPL-80-2424-15S-1.5K	80"	94"	523	1,500	15"	24" x 24"	15"/21"
261077	PSPL-90-2424-15S-1.5K	90"	104"	563	1,500	15"	24" x 24"	15"/21"
261088	PSPL-60-2427-20S-2K	60"	72"	476	2,000	15"	27" x 24"	20"/26"
261089	PSPL-68-2427-20S-2K	68"	83"	487	2,000	15"	27" x 24"	20"/26"
261090	PSPL-80-2427-20S-2K	80"	94"	530	2,000	15"	27" x 24"	20"/26"
261091	PSPL-90-2427-20S-2K	90"	104"	569	2,000	15"	27" x 24"	20"/26"
261071	PSPL-60-3032-30S-1.5K	60"	72"	479	1,500	18"	32" x 30"	30"/36"
261072	PSPL-68-3032-30S-1.5K	68"	83"	492	1,500	18"	32" x 30"	30"/36"
261073	PSPL-80-3032-30S-1.5K	80"	94"	534	1,500	18"	32" x 30"	30"/36"
261078	PSPL-90-3032-30S-1.5K	90"	104"	573	1,500	18"	32" x 30"	30"/36"
261056	PSPL-60-3032-30S-2K	60"	72"	484	2,000	18"	32" x 30"	30"/36"
261057	PSPL-68-3032-30S-2K	68"	83"	497	2,000	18"	32" x 30"	30"/36"
261058	PSPL-80-3032-30S-2K	80"	94"	539	2,000	18"	32" x 30"	30"/36"
261087	PSPL-90-3032-30S-2K	90"	104"	578	2,000	18"	32" x 30"	30"/36"
262056	PDPL-61-3033-30S-2K	61.375"	74.75"	674	2,000	18.25"	33" x 30"	30"/36"

LIFT EQUIPMENT



Easy fingertip controls.



High torque motor drive.

Optional Power Drive System for Fork and Platform Stackers

- Variable speed, steerable power drive system allows a single user to easily control forward and reverse movement of stacker.
- Simple to use finger-tip controls are built into steering handle.
- 180° hinged design allows precision steering in confined spaces.
- Spring-loaded mechanism automatically compensates for uneven floors ensuring drive wheels maintain constant contact with floor.
- Two maintenance-free sealed batteries provide plenty of power for propulsion and lift.
- 1,000 - 2,000 lb. capacities.
- Automatic emergency safety switch instantly reverses direction if control post comes in contact with obstacle.

Battery Powered System provides both propulsion and lift!

Eliminates the stress and strain of lifting and transporting heavy loads. All Wesco power lift stackers can be ordered as power drive models (except for telescoping models). All other operating specifications are the same as equivalent power lift-only models.

To order, simply add "-PD" to the end of the Model #.



Model # PSFL-86-25-20S-2K-PD
2,000 lb. capacity and 86" lift height



Model # PESPL-80-2424-PD
1,000 lb. capacity platform model with 80" lift height



Model # PCBFL-64-25-PD
1,000 lb. capacity counter-balance model

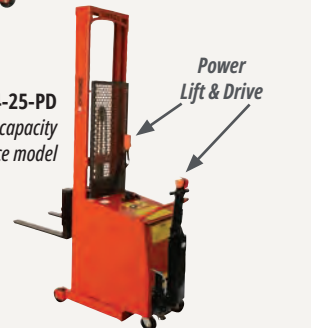



LT-02-1616



LT-10-1836

Features:

- Capacity ranges from 200 to 6,000 lbs.
- Solid steel top and base construction.
- Casters provide easy mobility.
- Floor locks are standard on all 500 lb.+ capacity tables.



Wesco Standard Duty Tables (200 - 1,000 lb Capacities)

- 1-year warranty.
- LT-02-1616 has four 3" hard rubber swivel casters.
- LT-02-1616 ships via UPS knocked down.
- LT-05 and LT-10 models feature 2 rigid and 2 swivel 4" phenolic resin roller bearing wheel casters.
- 7 Gauge steel top and base.
- 3/8" lift per stroke.



Wesco Medium & Heavy Duty Tables (2,000-6,000 lb Capacities)

- 1-year warranty.
- LT models feature 2 rigid and 2 swivel 6" phenolic resin roller bearing wheel casters.
- Four support posts and push handle.
- Foot operated floor lock.
- LTL models feature 2 rigid and 2 swivel 4" phenolic resin roller bearing wheel casters.
- Wesco made hydraulic pump with 3/8" lift per stroke.



LT-60-2436

OVERALL DIMENSIONS

w:	16"	18"	18"
h:	28.5"	30.5"	30.5"
d:	16"	21.25"	39.25"

OVERALL DIMENSIONS

w:	24"	32"	24"	32"	24"	32"	24"	32"	24"	32"
h:	30.5"	30.5"	37"	37"	37"	37"	37"	37"	37"	37"
d:	39.25"	51.25"	39.25"	51.25"	39.25"	51.25"	39.25"	51.25"	39.25"	51.25"

Part # Model #	260059 LT-02-1616	260060 LT-05-1818	260061 LT-10-1836	260062 LTL-20-2436	260063 LTL-20-3248	260064 LT-20-2436	260065 LT-20-3248	260066 LT-40-2436	260067 LT-40-3248	260068 LT-60-2436	260069 LT-60-3248
Capacity	200 lbs	500 lbs	1,000 lbs	2,000 lbs	2,000 lbs	2,000 lbs	2,000 lbs	4,000 lbs	4,000 lbs	6,000 lbs	6,000 lbs
Table Size W x L	16" x 16"	18" x 18"	18" x 36"	24" x 36"	32" x 48"	24" x 36"	32" x 48"	24" x 36"	32" x 48"	24" x 36"	32" x 48"
Lowered Height	28.5"	30.5"	30.5"	30.5"	30.5"	37"	37"	37"	37"	37"	37"
Raised Height	46"	47.5"	47.5"	47.5"	47.5"	59"	59"	59"	59"	59"	59"
Caster Size	3"	4"	4"	4"	4"	6"	6"	6"	6"	6"	6"
Support Posts	None	2	2	4	4	4	4	4	4	4	4
Weight	54 lbs	122 lbs	168 lbs	308 lbs	350 lbs	339 lbs	465 lbs	349 lbs	475 lbs	359 lbs	485 lbs



260297

Cantilever Lift Table

- Adjustable workbench or positioning table.
- Solid steel top and base construction.
- Single floor lock on the operator (handle) end.
- Two 6" swivel phenolic roller bearing casters located on operator (handle) end for easy maneuverability.
- Two 6" fixed phenolic roller bearing casters at the far end of the table.
- Four support posts.
- No Assembly Required

Part # Model #	260297 LT-40-3260
Lowered Height	37 in
Wheel Diameter	6 in
Weight	475 lbs
Platform Width	32 in
Raised Height	59 in
Weight Capacity	4000 lbs
Platform Length	60 in
Lift Type	Hydraulic
Control	Foot Operated
Lift Time	29 Strokes
Operation	Manual

5 Table-Top Options



- Factory installed only.
- Call for price.
- Not available on 16" or 18" wide tables.
- For both manual and powered Wesco-made tables only.
- Table capacity determines option capacity.
- Roller: diameter 1.9" with 7/16" hex axle.
- 1 3/8" diameter ball transfer.
- Push-Pull and Roller Top options have two directions of travel: length or width.
- **To order:**
- select table Part No. (manual or powered).
- select Option and add as suffix to table Part No.
- Example: 260062-PPL
24" x 36", 2,000 lb. capacity, manual table with a Push-Pull option that travels the length of the table.

PPL (Push-Pull)

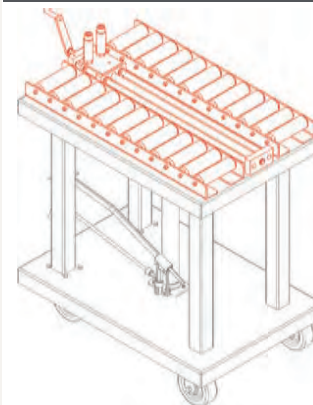

Travel: Length of table
Suffix Code: PPL
Table top to top of roller: 3"

Remote control for raising/lowering. Magnets on back of remote allow for storage anywhere on table.



261102



Powered Lift Tables

- 1-year warranty.
- Up to 6,000 lbs capacity.
- High volume output pump raises 1.5" per second without load.
- Standard floor lock holds table steady for loading and unloading.
- Easy to read illuminated battery status voltmeter.
- With a minimally charged battery, unit can be used while recharging.

Push-pull, roller and ball tops available on Wesco 24" x 36" and 32" x 48" manual and power tables.

Available with Power Drive

- Combines power lift and power drive capabilities.
- Power drive option weighs 160 lbs.
- To order Power Drive, add -PD to the end of Model #.

Example:

Lift Table Power Drive
#PLT-10-1836 #PLT-10-1836-PD



Shown With Power Drive Option - 261105-PD

OVERALL DIMENSIONS

w: 18"	24"	32"	24"	32"	24"	32"	24"	32"
h: 30.5"	30.5"	30.5"	37"	37"	37"	37"	37"	37"
d: 39.25"	39.25"	51.25"	39.25"	51.25"	39.25"	51.25"	39.25"	51.25"

Part # Model #	261108 PLT-10-1836	261100 PLTL-20-2436	261101 PLTL-20-3248	261102 PLT-20-2436	261103 PLT-20-3248	261104 PLT-40-2436	261105 PLT-40-3248	261106 PLT-60-2436	261107 PLT-60-3248
Capacity	1,000 lbs	2,000 lbs	2,000 lbs	2,000 lbs	2,000 lbs	4,000 lbs	4,000 lbs	6,000 lbs	6,000 lbs
Table Top W x L	18" x 36"	24" x 36"	32" x 48"	24" x 36"	32" x 48"	24" x 36"	32" x 48"	24" x 36"	32" x 48"
Raised Ht	47.5"	47.5"	47.5"	59"	59"	59"	59"	59"	59"
Lowered Ht	30.5"	30.5"	30.5"	37"	37"	37"	37"	37"	37"
Caster Size	4"	4"	4"	6"	6"	6"	6"	6"	6"
Weight	415 lbs	472 lbs	597 lbs	567 lbs	607 lbs	597 lbs	607 lbs	597 lbs	607 lbs

PPW (Push-Pull)

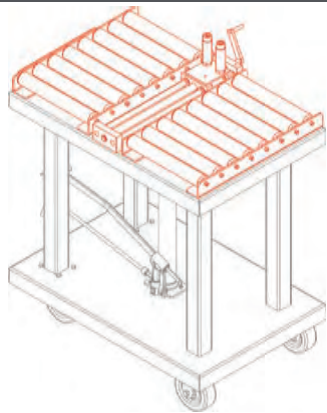

Travel: Width of table
Suffix Code: PPW
Table top to top of roller: 3"

RTL (Roller-Top)

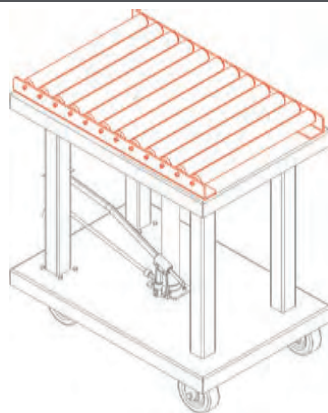

Travel: Length of table
Suffix Code: RTL
Table top to top of roller: 3"

RTW (Roller-Top)

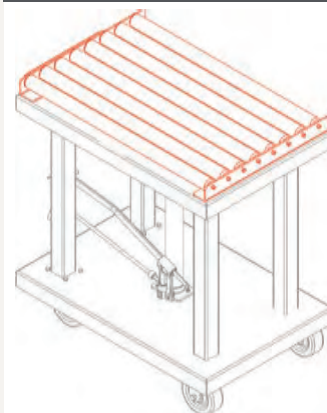

Travel: Width of table
Suffix Code: RTW
Table top to top of roller: 3"

BT (Ball Transfer)

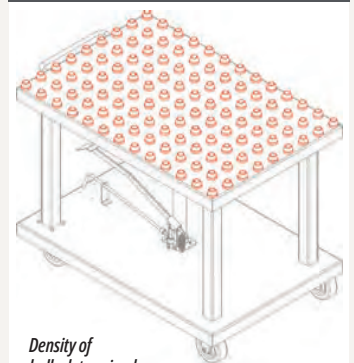

Density of balls determined by table top size and capacity.

1" diameter balls
Suffix Code: BT
Table top to top of ball: 1 3/8"



HT-200-FR



200 lb. Capacity Foot Operated Hydraulic Lift Table

- 1-year warranty.
- Top and base 1/4" steel.
- Top rotates 360°.
- 4 swivel 2" diameter rubber casters.



300 lb. Capacity Foot Operated Hydraulic Lift Table

- 1-year warranty.
- Top and base 3/8" steel.
- 2 rigid and 2 swivel 3 1/2" diameter rubber casters.
- Optional phenolic resin and polyurethane caster wheels.
- Floor lock.
- Two posts.



ALSO SEE WESCO LIFT TABLES ON PAGE 72.

LT-02-1616

LT-05-1818

Part # Model #	492220 HT-200-FR	492221 HT-203-FR	492222 HT-201-FR	492223 HT-209-FR	492224 HT-300-FR	492225 HT-318-FR	492226 HT-316-FR	492227 HT-314-FR	492228 HT-312-FR
Capacity	200 lbs	200 lbs	200 lbs	200 lbs	300 lbs	300 lbs	300 lbs	300 lbs	300 lb
Table Size	16" x 16"	16" x 16"	16" x 16"	16" x 16"	18" x 18"	18" x 18"	18" x 18"	18" x 18"	18" x 18"
Lowered Height	26"	24"	22"	20"	30"	28"	26"	24"	22"
Raised Height	44"	40"	36"	32"	48"	46"	42"	38"	34"
Caster Size	2"	2"	2"	2"	3.5"	3.5"	3.5"	3.5"	3.5"
Lift	18"	16"	14"	12"	18"	18"	16"	14"	12"
Weight	53 lbs	52 lbs	51 lbs	50 lbs	135 lbs	131 lbs	128 lbs	124 lbs	121 lbs



400 lb. & 500 lb. Capacity Foot Operated Hydraulic Lift Table

- 1-year warranty.
- Top and base 12 gauge steel.
- 2 rigid and 2 swivel 5" diameter rubber casters.
- Floor lock.
- Optional phenolic resin, polyurethane and steel caster wheels.
- Precision telescoping guide tubes.



HT-500-FR



HT-2388-05-FR with Drop-Base

Part # Model #	492229 HT-400-FR	492230 HT-416-FR	492231 HT-414-FR	492232 HT-412-FR	496037 HT-500-FR	492234 HT-2388-05-FR	492235 HT-2368-05-FR	492236 HT-2346-05-FR	492237 HT-2324-05-FR	492238 HT-2302-05-FR
Capacity	400 lbs	400 lbs	400 lbs	400 lbs	500 lbs	500 lbs	500 lbs	500 lbs	500 lbs	500 lbs
Table Size W x L	18" x 24"	18" x 24"	18" x 24"	18" x 24"	20" x 30"	20" x 30"	20" x 30"	20" x 30"	20" x 30"	20" x 30"
Lowered Height	30"	28"	26"	24"	30"	28"	26"	24"	22"	20"
Raised Height	48"	44"	40"	36"	48"	46"	44"	40"	36"	32"
Caster Size	5"	5"	5"	5"	5"	5"	5"	5"	5"	5"
Lift	18"	16"	14"	12"	18"	18"	18"	16"	14"	12"
Weight	119 lbs	115 lbs	112 lbs	108 lbs	142 lbs	173 lbs	180 lbs	176 lbs	170 lbs	164 lbs
Base	Flat	Flat	Flat	Flat	Flat	Drop	Drop	Drop	Drop	Drop

2,000 LB. LIFT TABLES & OPTIONAL CONVEYOR TOP



492204

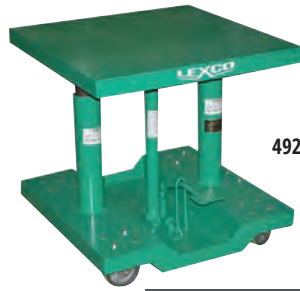

492199



499811
(20" x 30" #492205 Table with #499206 Optional Push-Pull attached.)



2,000 lb. Capacity Foot Operated Hydraulic Lift Table

- 1-year warranty.
- Precision telescoping guide tubes.
- ¼" reinforced steel top and base.
- 5" diameter steel caster wheels.
- 2 rigid/2 swivel/1 floor lock on 20" x 30" and 30" x 30" models.
- 4 swivel casters/2 floor locks on 30" x 48" models.
- AC & DC power custom tables available. *Call for details.*
- Compatible with optional Push Pull Conveyor Top.
- **Push Pull Die Conveyor Top may be ordered separately without table or attached to table top at factory.**

Part #	492204	492205	492206	492207	492208	492209
Model #	HT-2338-2F	HT-2388-2F	HT-2368-2F	HT-2346-2F	HT-2324-2F	HT-2302-2F
Capacity	2,000 lbs	2,000 lbs	2,000 lbs	2,000 lbs	2,000 lbs	2,000 lbs
Table Size	20" x 30"	20" x 30"	20" x 30"	20" x 30"	20" x 30"	20" x 30"
Lowered Height	30"	28"	26"	24"	22"	20"
Raised Height	48"	46"	44"	40"	36"	32"
5" Steel Caster	2 rigid/ 2 swivel	2 rigid/ 2 swivel	2 rigid/ 2 swivel	2 rigid/ 2 swivel	2 rigid/ 2 swivel	2 rigid/ 2 swivel
Lift	18"	18"	18"	16"	14"	12"
Weight	215 lbs	216 lbs	224 lbs	220 lbs	213 lbs	208 lbs

↓ TABLE WITH PUSH-PULL ATTACHED AT FACTORY ↓

Part #	499800	499811	499820	499821	499822	499823
Model #	HTP-2338-2F	HTP-2388-2F	HTP-2368-2F	HTP-2346-2F	HTP-2324-2F	HTP-2302-2F
Lowered Height	33"	31"	29"	27"	25"	23"
Raised Height	51"	49"	47"	43"	39"	35"

Part #	492193	492199	492200	492201	492202	492203	492210	492211	492212	492213	492214	492215
Model #	HT-3338-2F	HT-3388-2F	HT3368-2F	HT-3346-2F	HT-3324-2F	HT-3302-2F	HT-3438-2F	HT-3488-2F	HT-3468-2F	HT-3446-2F	HT-3424-2F	HT-3402-2F
Capacity	2,000 lbs	2,000 lbs	2,000 lbs	2,000 lbs	2,000 lbs	2,000 lbs	2,000 lbs	2,000 lbs	2,000 lbs	2,000 lbs	2,000 lbs	2,000 lbs
Table Size	30" x 30"	30" x 30"	30" x 30"	30" x 30"	30" x 30"	30" x 30"	30" x 48"	30" x 48"	30" x 48"	30" x 48"	30" x 48"	30" x 48"
Lowered Height	30"	28"	26"	24"	22"	20"	30"	28"	26"	24"	22"	20"
Raised Height	48"	46"	44"	40"	36"	32"	48"	46"	44"	40"	36"	32"
5" Steel Caster	2 rigid/ 2 swivel	2 rigid/ 2 swivel	2 rigid/ 2 swivel	2 rigid/ 2 swivel	2 rigid/ 2 swivel	2 rigid/ 2 swivel	2 rigid/ 2 swivel	2 rigid/ 2 swivel	2 rigid/ 2 swivel	2 rigid/ 2 swivel	2 rigid/ 2 swivel	2 rigid/ 2 swivel
Lift	18"	18"	18"	16"	14"	12"	18"	18"	18"	16"	14"	12"
Weight	276 lbs	274 lbs	284 lbs	280 lbs	274 lbs	268 lbs	460 lbs	472 lbs	482 lbs	478 lbs	472 lbs	466 lbs

↓ TABLE WITH PUSH-PULL ATTACHED AT FACTORY ↓

Part #	499824	499825	499826	499827	499828	499829	499830	499831	499832	499833	499834	499835
Model #	HTP-3338-2F	HTP-3388-2F	HTP-3368-2F	HTP-3346-2F	HTP-3324-2F	HTP-3302-2F	HTP-3438-2F	HTP-3488-2F	HTP-3468-2F	HTP-3446-2F	HTP-3424-2F	HTP-3402-2F
Lowered Height	33"	31"	29"	27"	25"	23"	33"	31"	29"	27"	25"	23"
Raised Height	51"	49"	47"	43"	39"	35"	51"	49"	47"	43"	39"	35"

Optional Manual Push-Pull Conveyor Tops (Top only/without table.)



- **Optional top only, mounted on ¼" steel plate. Table not included.**
- 1-year warranty.
- Easier method for pushing and pulling loads to and from the unit.
- 5-lb. effort required to crank the handle.

- Sold as stand alone unit or assembled onto table.
- **Fits only 2,000 lb Lexco Model HT Lift Tables.**
- Fits 3 sizes of table tops: 20" x 30", 30" x 30" and 30" x 48" only.
- Drilling and layout required if purchased without table.

Part #	499206	499235	499237
Model #	1098	1106	SP-5746
Capacity	2,000 lbs	2,000 lbs	2,000 lbs
Fits Table Top W x L	20" x 30"	30" x 30"	30" x 48"
Max. Die Size W x L	20" x 23"	30" x 23"	30" x 41"
Direction of Travel	30"	30"	48"
Weight	123 lbs	143 lbs	225 lb

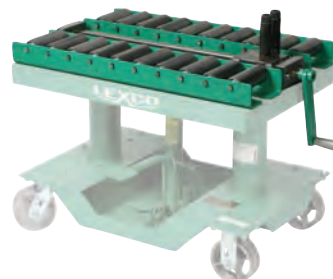

Photo illustrates Optional #499206 Push-Pull top. TABLE NOT INCLUDED.



3,000 - 6,000 lb. Foot Operated or Powered Portable Hydraulic Lift Tables

- 1-year warranty.
- AC and DC power options available.
- 1/4" steel top and base.
- 2 rigid and 2 swivel steel wheel casters.
- Standard designs available in 2 sizes: 30" x 30" and 48" x 30".
- Available in 4 capacities: 3,000 4,000 5,000 and 6,000.
- Precision telescoping guide tubes.
- Stabilizers included on 4,000, 5,000 and 6,000 models.



HT-3043-23

30" x 30" Tables

Part # Model #	496043 HT-3033-23	496044 HT-3033-22	496045 HT-3033-20	496046 HT-3033-18	496047 HT-3033-16	496048 HT-3034-23	496049 HT-3034-22	496050 HT-3034-20	496051 HT-3034-18	496038 HT-3034-16
Capacity	3,000 lbs	3,000 lbs	3,000 lbs	3,000 lbs	3,000 lbs	4,000 lbs	4,000 lbs	4,000 lbs	4,000 lbs	4,000 lbs
Table Size	30" x 30"	30" x 30"	30" x 30"	30" x 30"	30" x 30"	30" x 30"	30" x 30"	30" x 30"	30" x 30"	30" x 30"
Raised Height	54"	52"	48"	44"	40"	54"	52"	48"	44"	40"
Lowered Height	31"	30"	28"	26"	24"	31"	30"	28"	26"	24"
Casters	6"	6"	6"	6"	6"	6"	6"	6"	6"	6"
Weight - Foot Pedal	437 lbs	433 lbs	423 lbs	413 lbs	402 lbs	448 lbs	444 lbs	433 lbs	423 lbs	407 lbs
Weight - Electric	488 lbs	484 lbs	474 lbs	464 lbs	498 lbs	499 lbs	495 lbs	484 lbs	474 lbs	458 lbs

Part # Model #	496052 HT-3035-23	496053 HT-3035-22	496054 HT-3035-20	496055 HT-3035-18	496056 HT-3035-16	496057 HT-3036-23	496058 HT-3036-22	496059 HT-3036-20	496060 HT-3036-18	496061 HT-3036-16
Capacity	5,000 lbs	5,000 lbs	5,000 lbs	5,000 lbs	5,000 lbs	6,000 lbs	6,000 lbs	6,000 lbs	6,000 lbs	6,000 lbs
Table Size	30" x 30"	30" x 30"	30" x 30"	30" x 30"	30" x 30"	30" x 30"	30" x 30"	30" x 30"	30" x 30"	30" x 30"
Raised Height	54"	52"	48"	44"	40"	54"	52"	48"	44"	40"
Lowered Height	31"	30"	28"	26"	24"	31"	30"	28"	26"	24"
Casters	6"	6"	6"	6"	6"	6"	6"	6"	6"	6"
Weight - Foot Pedal	476 lbs	472 lbs	461 lbs	451 lbs	435 lbs	480 lbs	476 lbs	465 lbs	454 lbs	437 lbs
Weight - Electric	527 lbs	523 lbs	512 lbs	502 lbs	486 lbs	531 lbs	527 lbs	516 lbs	505 lbs	488 lbs

48" x 30" Tables

Part # Model #	496062 HT-3043-23	496063 HT-3043-22	496064 HT-3043-20	496065 HT-3043-18	496066 HT-3043-16	496067 HT-3044-23	496068 HT-3044-22	496069 HT-3044-20	496070 HT-3044-18	496071 HT-3044-16
Capacity	3,000 lbs	3,000 lbs	3,000 lbs	3,000 lbs	3,000 lbs	4,000 lbs	4,000 lbs	4,000 lbs	4,000 lbs	4,000 lbs
Table Size	48" x 30"	48" x 30"	48" x 30"	48" x 30"	48" x 30"	48" x 30"	48" x 30"	48" x 30"	48" x 30"	48" x 30"
Raised Height	54"	52"	48"	44"	40"	54"	52"	48"	44"	40"
Lowered Height	31"	30"	28"	26"	24"	31"	30"	28"	26"	24"
Casters	6"	6"	6"	6"	6"	6"	6"	6"	6"	6"
Weight - Foot Pedal	555 lbs	551 lbs	540 lbs	530 lbs	520 lbs	568 lbs	563 lbs	553 lbs	543 lbs	526 lbs
Weight - Electric	606 lbs	602 lbs	591 lbs	581 lbs	571 lbs	619 lbs	614 lbs	604 lbs	594 lbs	577 lbs

Part # Model #	496072 HT-3045-23	496073 HT-3045-22	496074 HT-3045-20	496075 HT-3045-18	496076 HT-3045-16	496077 HT-3046-23	496078 HT-3046-22	496079 HT-3046-20	496080 HT-3046-18	496081 HT-3046-16
Capacity	5,000 lbs	5,000 lbs	5,000 lbs	5,000 lbs	5,000 lbs	6,000 lbs	6,000 lbs	6,000 lbs	6,000 lbs	6,000 lbs
Table Size	48" x 30"	48" x 30"	48" x 30"	48" x 30"	48" x 30"	48" x 30"	48" x 30"	48" x 30"	48" x 30"	48" x 30"
Raised Height	54"	52"	48"	44"	40"	54"	52"	48"	44"	40"
Lowered Height	31"	30"	28"	26"	24"	31"	30"	28"	26"	24"
Casters	6"	6"	6"	6"	6"	6"	6"	6"	6"	6"
Weight - Foot Pedal	600 lbs	596 lbs	585 lbs	575 lbs	559 lbs	604 lbs	600 lbs	589 lbs	578 lbs	562 lbs
Weight - Electric	651 lbs	647 lbs	636 lbs	626 lbs	610 lbs	655 lbs	651 lbs	640 lbs	629 lbs	613 lbs

Other sizes also available. Call for details.

- 30" wide x 60", 72", 96" and 120" long.
- 36" wide x 60", 72", 96" and 120" long.
- 48" wide x 60", 72", 96" and 120" long.
- These sizes with 2 rigid and 2 swivel 8" diameter steel wheel casters and two floor locks.



2,000 lb. Capacity Long-Deck Hydraulic Foot-Operated Lift Tables



Call for information on powered models.

- 1-year warranty.
- AC and DC power options available.
- Standard lift height 30" - 48".
- Optional lift ranges available, call factory.
- 10 gauge steel top.
- Foot operated.
- Precision telescoping guide tubes.
- 4 swivel 5" diameter steel wheels or optional polyurethane wheels.
- 2 floor locks.

Part # Model #	492239 STN-2005-2F	492240 STN-2006-2F	492241 STN-2008-2F	492242 STN-2010-2F	492128 STN-3005-2F	492129 STN-3006-2F	492130 STN-3008-2F	492131 STN-3010-2F
Capacity	2,000 lbs	2,000 lbs	2,000 lbs	2,000 lbs	2,000 lbs	2,000 lbs	2,000 lbs	2,000 lbs
Table Size	5' x 20"	6' x 20"	8' x 20"	10' x 20"	5' x 30"	6' x 30"	8' x 30"	10' x 30"
Raised Height	48"	48"	48"	48"	48"	48"	48"	48"
Lowered Height	30"	30"	30"	30"	30"	30"	30"	30"
Casters	5"	5"	5"	5"	5"	5"	5"	5"
Weight	384 lbs	400 lbs	459 lbs	505 lbs	423 lbs	457 lbs	512 lbs	568 lbs



3,000 & 5,000 lb. Capacity Long-Deck Hydraulic Foot-Operated Lift Tables



Call for information on powered models.

- 1-year warranty.
- AC and DC power options available.
- Load stabilizer assembly on 5,000 lb models.
- 2 floor locks.
- Precision telescoping guide tubes.
- Table top 3,000 lb. models: .25" thick steel.
- Table top 5,000 lb. models: .25" thick steel.

**STN-3608-5F
With Load Stabilizer**

Part # Model #	492250 STN-3605-3F	492251 STN-3606-3F	492252 STN-3608-3F	492253 STN-3610-3F	492254 STN-3605-5F	492255 STN-3606-5F	492256 STN-3608-5F	492257 STN-3610-5F
Capacity	3,000 lbs	3,000 lbs	3,000 lbs	3,000 lbs	5,000 lbs	5,000 lbs	5,000 lbs	5,000 lbs
Table Size	5' x 36"	6' x 36"	8' x 36"	10' x 36"	5' x 36"	6' x 36"	8' x 36"	10' x 36"
Raised Height	56.375"	56.375"	56.375"	56.375"	53.125"	53.125"	53.125"	53.125"
Lowered Height	36.375"	36.375"	36.375"	36.375"	33.125"	33.125"	33.125"	33.125"
Casters	8" steel wheels 4 / swivel	8" steel wheels 4 / swivel	8" steel wheels 4 / swivel	8" steel wheels 4 / swivel	8" steel wheels 2 swivel & brake 2 rigid	8" steel wheels 2 swivel & brake 2 rigid	8" steel wheels 2 swivel & brake 2 rigid	8" steel wheels 2 swivel & brake 2 rigid
Weight	811 lbs	846 lbs	954 lbs	1,026 lbs	1,010 lbs	1,074 lbs	1,397 lbs	1,486 lbs



The DH series hydraulic die handler is a cost effective mobile die cart that allows you to transport, separate, and present your dies for service and maintenance.

2,000, 3,000 & 4,000 lb. Capacity Die Handlers

- 1-year warranty.
- Heavy-duty steel adjustable clamps for gripping the upper die set for separation.
- Floor lock.
- Precision telescoping guide tubes.
- Rigid die hangers with 360° indexing plate.
- Optional gantry heights available upon request.

Call for
information
on powered
models.

Model DH-3005-43



Part # Model #	499243 DH-3339-22	499244 DH-3438-24	499245 DH-3043-22	499246 DH-3005-43
Capacity	2,000lbs	2,000lbs	3,000 lbs	4,000 lbs
Table Top W x L	30" x 30"	30" x 48"	30" x 48"	30" x 60"
Raised Height	48"	48"	52"	55"
Lowered Height	30"	30"	30"	32"
Minimum Clearance under Bar to Table Top	19.885"	19.885"	20.5"	20.5"
Caster Size/ Type	5" 2 swivel / 2 rigid	5" 4 swivel	6" 4 swivel	8" 2 swivel / 2 rigid
Max. Die Size	30" x 24"	42" x 30"	42" x 30"	54" x 30"
Weight	388 lbs	590 lbs	747 lbs	1,069 lbs

Precision Lift Tables

- 1/4" heavy duty welded steel construction
- Durable powder coat finish
- Long 13" crank handle for heavy loads.
- Handle positions at both table ends for optimum flexibility
- Two Lift Speeds:
 - 1/8" lift per rotation for heavy loads or precise load positioning
 - 1/4" lift per rotation for fast lift or light loads
- Heavy duty floor lock and locking swivel casters are standard
- Choice of cast iron or poly casters



Part #274680



OVERALL DIMENSIONS

w: 31.5"	31.5"	31.5"	31.5"
h: 25.6"	25.6"	25.6"	25.6"
d: 37.8"	37.8"	49.2"	49.2"

Part # Model #	274683 HCLT-2436-P	274680 HCLT-2436-CI	274684 HCLT-3048-P	274681 HCLT-3048-CI
Capacity	2,200 lbs.	2,200 lbs.	2,200 lbs.	2,200 lbs.
Table W x L	24" x 36"	24" x 36"	30" x 48"	30" x 48"
Raised Height	42"	42"	42"	42"
Lowered Height	24"	24"	24"	24"
Wheel	Poly	Cast Iron	Poly	Cast Iron
Caster Size/ Type	5" 2 rigid / 2 swivel w/brake	5" 2 rigid / 2 swivel w/brake	5" 2 rigid / 2 swivel w/brake	5" 2 rigid / 2 swivel w/brake
Weight	317 lbs.	321 lbs.	420 lbs.	421 lbs.



LT-330SL

Folding Handle Scissors Lift Table

- Folding handle lays flat on table top.
- Chrome plated handle and foot pedal.
- Lever release handle.
- Moldon polyurethane wheels and locking swivel casters.
- Foot operated pump.



LT-700SL



Fixed Handle Scissors Tables

- Fixed handle.
- Foot operated pump.
- Easy to use spring loaded release lever.
- 5" x 1.5" moldon polyurethane wheels and locking casters.



LT-770DSL



Double Scissors High Lift Tables

- Fixed handle.
- Chrome plated handle and foot pedal.
- Lever release handle.
- 5" x 1.5" moldon polyurethane wheels and locking swivel casters.
- Foot operated pump.



LT-2200SL



LT-1650SL

Heavy Duty Scissors Lift Tables

- Fixed handle.
- Chrome plated handle and foot pedal.
- 5" x 2" moldon polyurethane wheels and locking swivel casters.
- Foot operated pump.

OVERALL DIMENSIONS

w: 17.75"
h: 37"
d: 36"

20"
39"
37"

19.5"
39"
42"

20"
39"
37"

w: 19.5"
h: 37"
d: 42"

19.5"
37"
42"

w: 19.5"
h: 37"
d: 45.5"

24"
37"
58"

w: 20"
h: 39.5"
d: 49"

20"
39.5"
50"

Part # Model #	260201 LT-330SL	260207 SLT-660-11	272974 LT-660FHSL	260208 SLT-1100-11	260199 LT-700SL	260200 LT-1000SL	260204 LT-770DSL	272862 LT-1540DSL	272970 LT-1650SL	272973 LT-2200SL
Capacity	330 lbs	660 lbs	660 lbs	1,100 lbs	700 lbs	1,000 lbs	770 lbs	1,540 lbs	1,650 lbs	2,200 lbs
Table Size	17.75" x 27.5"	20" x 32"	19.5" x 32"	20" x 32"	19.5" x 32"	19.5" x 32"	19.5" x 35.5"	24" x 48"	20" x 39"	20" x 40"
Raised Height	28.5"	35"	35"	35"	35"	35"	51"	59"	35.5"	39"
Lowered Height	8.5"	11"	14"	11"	14"	14"	14"	17.75"	16.5"	15"
Caster Size	4" x 1"	5" x 1.5"	5" x 1.5"	5" x 1.5"	5" x 1.5"	5" x 1.5"	5" x 1.5"	5" x 1.5"	5" x 2"	5" x 2"
Locking Caster (LC)	LC	LC	LC	LC	LC	LC	LC	LC	LC	LC
Weight	98 lbs	165 lbs	170 lbs	187 lbs	170 lbs	185 lbs	227 lbs	430 lbs	276 lbs	269 lbs

TABLE TOP SIZES

- 32" Wide x 63" Long
- 30" wide x 80" Long



273261



Manually operated safety bars lock table in raised position.

Long Deck Scissors Table

- Oversized **63" long** x 32" wide and **80" long** x 30" wide table tops accommodate large cargo.
- Two wheels and two locking swivel casters.
- Handle height - 38" (32" x 63" table)
39" (30" x 80" table).
- Hydraulic foot pump.
- Safety bars.
- Table top thickness: .125" (3mm).

OVERALL DIMENSIONS

w: 32"
h: 38"
d: 74.25"

34.5"
53.5"
80.125"



273269



Scissors Table with Roller Top

- Roller top permits easy movement of cargo for loading and unloading.
- Two locking swivel casters - 5" x 1½" moldon polyurethane.
- Two 5" x 1½" moldon polyurethane casters.
- Handle height - 38¼".
- Two dual-position end stops help keep cargo in place.
- Eight 2" diameter rollers 18½" long.
- Hydraulic foot pump.
- Variable lowering speed valve.

w: 20.25"
h: 38.25"
d: 43"



273265

Hydraulic Die Lift Table

- Table top size - 24" x 36".
- Handle height - 36.75".
- Two swivel locking casters - 5" x 1½" moldon polyurethane.
- Hydraulic foot pump.
- Removable handle - may also be reversed for use in confined areas.
- Variable lowering speed.

w: 24"
h: 36.75"
d: 49.5"

Part # Model #	273261 LDT-3263	273230 LDT-3080	273269 DRT-2033	273265 DT-2436
Capacity	1,100 lbs	2,200 lbs	660 lbs	2,000 lbs
Table Size	32" x 63"	30" x 80"	19.5" x 32.5"	24" x 36"
Raised Height	36"	53.5"	38.25"	36"
Lowered Height	11.25"	14.2"	12.5"	24.25"
Caster Size/ Type	5" x 1.5" Moldon Polyurethane	Nylon 3" x 1.5" swivel 7" x 2" wheel	5" x 1.5"	5" x 1.5"
Weight	340 lbs	440 lbs	210 lbs	265 lbs



273710



273713



273711



273712



270662



Powered Lift Scissors Table

- 12 volt rechargeable, deep cycle batteries with onboard charger and battery gauge.
- Moldon polyurethane wheels and locking swivel casters.
- Chrome plated handle.
- Keyed on/off switch.

- Raised-height limit switch.
- Push-button pendent can be removed for hand held operation.
- Overload bypass valve.
- Emergency stop button.

Mini Electric Lift Table

- Heavy duty to handle tough loads.
- Small and light enough to move.
- Full perimeter safety bar stops table from lowering if it contacts an obstruction.
- 110V 60 Hz.
- Push button station.

OVERALL DIMENSIONS

w: 19.75"	20.5"	24.5"	19.625"
h: 36"	38"	36.25"	36"
d: 45.25"	52"	53.75"	47.75"

OVERALL DIMENSIONS

w: 24"
h: 30"
d: 35"

Part # Model #	273710 PSLT-660	273711 PSLT-1100	273712 PSLT-1650	273713 PSLT-770-DS	270662 MELT
Capacity	660 lbs	1,100 lbs	1,650 lbs	770 lbs	2,200 lbs (Double Scissors)
Table Size W x L	19.75" x 33.5" x 2"	20.5" x 39.75" x 2.25"	20" x 39.5" x 2.25"	19.625" x 35.875" x 2.25"	24" x 35"
Raised Height	34.25"	40.5"	39.5"	51.5"	30"
Lowered Height	11.25"	17.25"	17"	14.5"	7"
Caster Size	5" x 1.25"	6" x 1.5"	6" x 2"	5" x 1.25"	N/A
Qty. of batteries	4	2	4	4	N/A
Weight	256 lbs	346 lbs	353 lbs	300 lbs	283 lbs

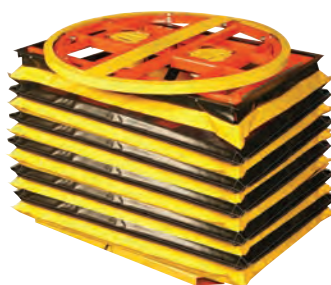

Protective Skirt Part # 275001

- Option must be ordered as a separate item.
- Only available as factory installed.
- Fits both spring and pneumatic pallet levelers.

Pallet Leveler

- The pallet leveler progressively lowers as pallet is loaded and raises as pallet is unloaded.
- 3 Heavy duty calibrated springs used in combination according to desired load range.
- Bearing supported carousel for easy turning.
- Built in fork pockets for ease of transport.
- Helps reduce fatigue and injury from bending and lifting.

OVERALL DIMENSIONS

w: 36"
h: 9.25" Compressed / 29" Raised
d: 45.5"



272696

Pneumatic Pallet Leveler

- The pneumatic pallet leveler progressively lowers as pallet is loaded and raises as pallet is unloaded.
- Pneumatic bellows actuates raising and lowering of loads.
- 80 PSI of initial air pressure required.
- Air tank and controls are self-contained and do not require constant air pressure.
- Removable tank and controls for remote operation; 48" of hose included.

OVERALL DIMENSIONS

w: 36"
h: 12.55" Compressed / 28.5" Raised
d: 45.5"

Part # Model #	272986 PL	272696 PPL
Capacity	400-4,500 lbs	4,500 lb maximum
Raised Height	29"	28.5" (without load)
Lowered Height	9.25"	12.5"
Carousel Diameter	40.75"	40.75"
Rotating Ring Diameter	43.5"	43.5"
Fork Pocket L x W	39" x 5.75"	39" x 5.75"
Load Size	72" x 50" x 50"	72" x 50" x 50"
Weight	352 lbs	322 lbs



Features:

- Heavy duty capacities up to 5 tons - the most economical way to lift and move large bulky loads.
- Swivel casters allow movement in any direction.
- Hand operated hydraulic jack for easy lifting and controlled lowering of loads.
- All models supplied with hooks for recommended optional LB-1 or LB-2 load binders.



RNR-2



**Rais-N-Rol™
2,000 lb
Capacity
Per Pair**

- 23" wide x 13.25" deep x 47.25" high (lowered height).
- I.D. fork span range 7.25" to 17.5".

OVERALL DIMENSIONS
w: 23"
h: 47.25"
d: 15.25"



RNR-4



**Rais-N-Rol™
4,000 lb
Capacity
Per Pair**

- 23" wide x 16.875" deep x 43.5" high (lowered height).
- I.D. fork span range 5" to 19.5".

OVERALL DIMENSIONS
w: 23"
h: 43.5"
d: 18.5"



RNR-6P



**Rais-N-Rol™ 6,000 lb
Capacity Per Pair**

- 23" wide x 16.875" deep.
- RNR-6(P): 43.5" H; RNR-64(P): 43.5" H.
- I.D. fork span range 6" to 19.5".

OVERALL DIMENSIONS
w: 23"
h: 43.5"
d: 18.375"



RNR-8



**Rais-N-Rol™
8,000 lb
Capacity
Per Pair**

- 24" wide x 18.625" deep x 47" high (lowered height).
- I.D. fork span range 6" to 19.5".

OVERALL DIMENSIONS
w: 23"
h: 43.5"
d: 18.375"



RNR-10



**Rais-N-Rol™
10,000 lb
Capacity
Per Pair**

- 24" wide x 18.625" deep x 47" high (lowered height).
- I.D. fork span range 6" to 19.5".

OVERALL DIMENSIONS
w: 24"
h: 47"
d: 21.75"

Part # Model #	260086 RNR-2	260091 RNR-2P	260087 RNR-4	260092 RNR-4P	260088 RNR-6	260093 RNR-6P	260138 RNR-64	260139 RNR-64P	260089 RNR-8	260094 RNR-8P	260090 RNR-10	260095 RNR-10P
Capacity	2,000 lbs	2,000 lbs	4,000 lbs	4,000 lbs	6,000 lbs	6,000 lbs	6,000 lbs	6,000 lbs	8,000 lbs	8,000 lbs	10,000 lbs	10,000 lbs
Lift	5"	5"	12"	12"	12"	12"	12"	12"	6"	6"	6"	6"
Casters	5" x 2" Phenolic	5" x 2" Polyurethane	6" x 2" Steel	6" x 2" Polyurethane	6" x 2.5" Steel	6" x 2.5" Polyurethane	6" x 2.5" Steel	6" x 2.5" Polyurethane	8" x 2.5" Steel	8" x 3" Polyurethane	8" x 2.5" Steel	8" x 3" Polyurethane
Weight	170 lbs/PR	176 lbs/PR	315 lbs/PR	313 lbs/PR	325 lbs/PR	306 lbs/PR	359 lbs/PR	359 lbs/PR	390 lbs/PR	402 lbs/PR	480 lbs/PR	475 lbs/PR

Option: Load Binder Accessory

- Two 12' long nylon belts with heavy duty ratchet tighteners.
- Highly recommended for stabilizing large loads.



LB-1

Part **Model #**
260096 LB-1 *Delta rings secure belt to Rais-N-Rol*
260147 LB-2 *"E" track hooks secure belt to Rais-N-Rol*

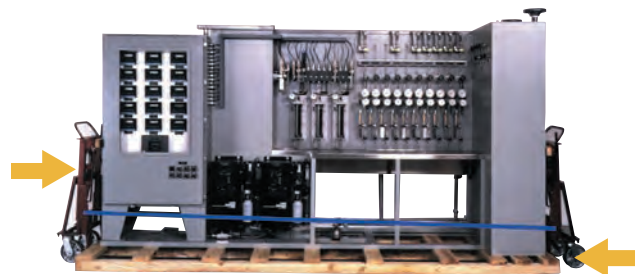

Panel becomes its own dolly.

Furniture Mover

- Sold in pairs only.
- Two models: Manual Lift / Hydraulic Lift
- Economically priced.
- Great for moving furniture or odd shaped loads.
- Straps to secure load standard.
- Hydraulic unit with ratcheting strap tightener.
- 6" swivel casters.



Hydraulic
272952



Manual
272951



OVERALL DIMENSIONS

w:	23"	26.5"
h:	32"	42"
d:	15"	16"

Part # Model #	272951 MFM	272952 HFM
Capacity	1,320 lbs per pair	3,950 lbs per pair
Lift Plate L x D	8.5" x 4.5"	23" X 2.25"
Lift Height	12"	10"
Casters	6" Moldon Polyurethane	6" Moldon Polyurethane
Weight	72 lbs	195 lbs

HeviMovers™ are made with precision ground and hardened steel rollers that form an endless chain which revolves around a central load-bearing plate in the frame. Weight of the load is transferred directly from load-bearing plate to rollers. This eliminates axle friction and requires less power to start and move the load. HeviMovers™ roll easily over cracks and pitted floor areas to reduce possible damage to goods.



480020



**Steel Deck
Machine
Dolly**

- .25" thick steel plate.
- 2" x .5" aircraft quality, heat treated steel wheels.



480002

**HeviMover™
Machine Rollers**

- Swivel-top for maximum maneuverability, full 360° rotation.
- Spring-loaded locking mechanism at 45° intervals.
- Only periodic cleaning and light re-oiling of roller chain needed.



480019

HeviMover™ Kit

- Includes 4 HMS-2 HeviMovers and 2 29" knocked down steering handles in a rugged steel tool box.

OVERALL DIMENSIONS

w:	8.5"
h:	2.5"
d:	11.75"

OVERALL DIMENSIONS

w:	3.125"	5.5"	5.75"	6.5"
h:	3.1875"	4.4375"	4.875"	4.875"
d:	8"	10"	10.5"	12.75"

OVERALL DIMENSIONS

w:	16"
h:	7"
d:	7"

Part # Model #	480020	480001 HMS-2	480002 HMS-8	480003 HMS-15	480004 HMS-30	480019 HMS-2K
Capacity	10,000 lbs	2,000 lbs	8,000 lbs	15,000 lbs	30,000 lbs	4 HMS - 2's @ 2,000 lbs ea.
Wheel Size	2" x .5"	N/A	N/A	N/A	N/A	N/A
Roller Width	NA	1.875"	3.25"	3.25"	4"	1.875"
Roller Diameter	NA	.6875"	.9375"	1.1875"	1.1875"	.6875"
Weight	11.5 lbs	10 lbs	31 lbs	39 lbs	52 lbs	55 lbs

HeviMover™ Options

- Steering handles.
- Turning bar.

Part # Model #	480005 HMH-36-1	480006 HMH-48-1
Description	36" steering handle for HMS-2	48" steering handle for HMS-2
Weight	6 lbs	7 lbs

Part # Model #	480007 HMH-36-2	480008 HMH-48-2
Description	36" steering handle for HMS-8, 15, 30	48" steering handle for HMS-8, 15, 30
Weight	6 lbs	7 lbs

Part # Model #	480009 HMH-TB-2
Description	36" turning bar for HMS-8, 15, 30
Weight	14.5 lbs

ALUMINUM PLATFORM TRUCK FEATURES:

- Aluminum is corrosion resistant and maintains clean appearance.
- Strong enough to handle up to 3,000 lbs (depending upon caster selection).
- Lightweight aluminum allows for easy maneuverability.
- Handle included.
- Corner sockets at both ends allow handles to be used on either or both ends of truck.
- For truck platform height, add 2.5" to caster height (see caster option chart).
- Bolt on casters. (Casters Sold Separately) – choose from caster option chart.

Extra Push Handle Option

- Truck Width 24" Part #052574
- 30" #052575
- 36" #052576

To order, add -PH2 to the end of Truck Model #.

Example: ASD-2436-PH2

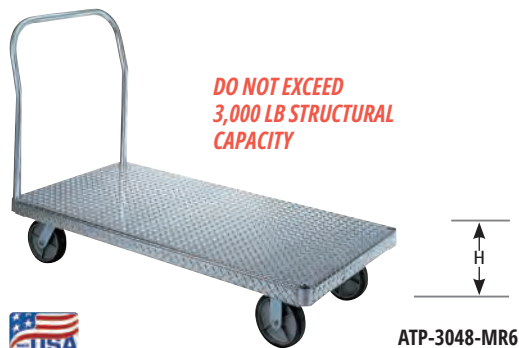

ATP Series - Aluminum Treadplate Mode

- Structural capacity of any size platform **NOT** to exceed 3,000 lbs.
- Slip-resistant diamond pattern surface.
- Solid one piece platform surface construction.



ASD Series - Aluminum Smooth Deck

- Structural capacity of any size platform **NOT** to exceed 3,000 lbs.
- Smooth surface that is easy to keep clean.
- Solid one piece platform surface construction.

OVERALL DIMENSIONS

w:	24"	24"	30"	30"	36"	36"
h:	2.5"	2.5"	2.5"	2.5"	2.5"	2.5"
d:	36"	48"	48"	60"	60"	72"

OVERALL DIMENSIONS

w:	24"	24"	30"	30"	36"	36"
h:	2.5"	2.5"	2.5"	2.5"	2.5"	2.5"
d:	36"	48"	48"	60"	60"	72"

Part # Model #	350036 ATP-2436	350037 ATP-2448	350039 ATP-3048	350040 ATP-3060	350042 ATP-3660	350043 ATP-3672	350027 ASD-2436	350028 ASD-2448	350030 ASD-3048	350031 ASD-3060	350033 ASD-3660	350034 ASD-3672
Structural Capacity	NOT TO EXCEED 3,000 LBS						NOT TO EXCEED 3,000 LBS					
Platform	24" x 36"	24" x 48"	30" x 48"	30" x 60"	36" x 60"	36" x 72"	24" x 36"	24" x 48"	30" x 48"	30" x 60"	36" x 60"	36" x 72"
Weight	32 lbs	40 lbs	45 lbs	54 lbs	61 lbs	71 lbs	27 lbs	33 lbs	37 lbs	44 lbs	49 lbs	59 lbs

Actual capacity of assembled platform is dependent upon caster capacity but should never exceed the platform's structural capacity, regardless of caster type.

Caster Options for ATP and ASD Series Platform Trucks Each Caster Set includes 2 rigid, 2 swivel casters.

Part # Model #	250046 SR-5A	250047 SR-5	250049 SR-6	250050 MR-6	250051 MP-6	250052 PR-6	250053 MR-8	250055 MP-8	250056 PR-8	250250 PN-8
Capacity	750 lbs	2,000 lbs	2,000 lbs	2,000 lbs	3,000 lbs	3,000 lbs	2,400 lbs	3,000 lbs	3,000 lbs	1,200 lbs
Wheel Size	5" x 1.5"	5" x 2"	6" x 2"	6" x 2"	6" x 2"	6" x 2"	8" x 2"	8" x 2"	8" x 2"	8" x 2.5"
Wheel Type	Polyolefin	Polyolefin	Polyolefin	Moldon Rubber	Moldon Polyurethane	Phenolic	Moldon Rubber	Moldon Polyurethane	Phenolic	Pneumatic
"H" Dimension Floor to Platform Top	9"	9.25"	10"	10"	10"	10"	12"	12"	12"	12.5"
Caster Height	6.50"	6.75"	7.5"	7.5"	7.5"	7.5"	9.5"	9.5"	9.5"	10"
Weight	14 lbs per set	20 lbs per set	26 lbs per set	26 lbs per set	24 lbs per set	26 lbs per set	28 lbs per set	27 lbs per set	30 lbs per set	29 lbs per set

Actual capacity of assembled platform is dependent upon caster capacity but should never exceed the platform's structural capacity, regardless of caster type.



Thrifty Plate Aluminum Tread Platform Trucks - Commercial Quality (Import)

- Structural capacity of any size platform **not** to exceed 2,400 lbs.
- Platforms and casters sold separately.
- Casters determine capacity - 2,400 lbs or less.
- Non-marking gray corner bumpers.
- Platform top to top of handle - 32".
- Replacement Corner Bumper Option - Part # 273611 (includes 4 bumpers + hardware).
- 24" Extra Push Handle - Part # 273609.
- 30" Extra Push Handle - Part # 273610.



Thrifty Plate Aluminum Tread Platform Trucks - Light Duty (Import)

- Structural capacity of any size platform not to exceed 1,200 lbs.
- Platforms and casters sold separately.
- Casters determine capacity - 1,200 lbs or less.
- Non-marking gray corner bumpers.
- Platform top to top of handle - 27.625".
- Replacement Corner Bumper Option - Part # 273616 (includes 4 bumpers + hardware).
- 24" Extra Push Handle - Part # 273614.
- 30" Extra Push Handle - Part # 273615.



Steel Grid Deck Platform Truck

- Sturdy open grate design provides high strength and prevents accumulation of water and small debris.
- Durable powder coat paint finish.
- (2) 8" x 2" rigid casters and (4) 6" x 1.5" swivel end casters.
- Tilt design allows truck to pivot on its own radius.
- Platform height 10.75", height to top of handle 35.5".

OVERALL DIMENSIONS

w:	25"	25"	31"	31"
h:	2.625"	2.625"	2.625"	2.625"
d:	37"	49"	49"	61"

OVERALL DIMENSIONS

w:	25"	25"	31"	31"
h:	1.625"	1.625"	1.625"	1.625"
d:	37"	49"	49"	61"

OVERALL DIMENSIONS

w:	30"
h:	35"
d:	63"

Part # Model #	273601 CQ2436	273602 CQ2448	273603 CQ3048	273604 CQ3060	273605 LD2436	273606 LD2448	273607 LD3048	273608 LD3060	273297
Structural Capacity	NOT TO EXCEED 2,400 LBS				NOT TO EXCEED 1200 LBS				1,750 lbs
Platform	24" x 36"	24" x 48"	30" x 48"	30" x 60"	24" x 36"	24" x 48"	30" x 48"	30" x 60"	30" x 50"
Weight	28 lbs	36 lbs	43 lbs	53 lbs	19 lbs	23 lbs	28 lbs	34 lbs	170 lbs

Actual capacity of assembled platform is dependent upon caster capacity but should never exceed the platform's structural capacity, regardless of caster type.

Caster Options for Thrifty Plate Platform Trucks *Each Caster Set includes 2 rigid and 2 swivel casters.*

Part #	273612	273613	172244	172245
Capacity	2,000 lbs	2,400 lbs	1,200 lbs	1,500 lbs
Wheel Size	6" x 2"	8" x 2"	8" x 2.5"	10" x 3.5"
Wheel Type	Moldon Rubber Aluminum Hub	Moldon Rubber Aluminum Hub	Full Pneumatic Zinc Steel Hub	Full Pneumatic Zinc Steel Hub
H-CQ Dimension - Floor to Platform Top	10.375"	12.125"	12.625"	14.625"
H-LD Dimension - Floor to Platform Top	9.375"	11.125"	11.625"	13.625"
Caster Height	7.75"	9.5"	10"	12"
Weight	26 lbs per set	28 lbs per set	26 lbs per set	34 lbs per set

Actual capacity of assembled platform is dependent upon caster capacity but should never exceed the platform's structural capacity, regardless of caster type.

STEEL PLATFORM TRUCK FEATURES:

- Heavy duty 12 gauge steel reinforced welded construction.
- Constructed for both standard corner or diamond caster mountin pattern.
- Removable two cross-brace handle can be inserted in either end.
- **Choose your caster: Platforms and casters sold separately, except #272265.**
- **All platforms include one handle. Additional handles available as an option. (except #272265).**
- All listed capacities are based on evenly distributed loads.

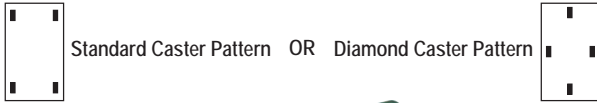

Steel Platform Trucks (Casters sold separately)

- 32" high handles from platform top.

**DO NOT EXCEED 4,000 LB
STRUCTURAL CAPACITY**

Economy Steel Platform Truck

- Ships complete. Platform, one handle, four 5" x 1.25" casters.
- Deck height - 5.75", handle height - 41".
- Maximum capacity 750 lbs.

	OVERALL DIMENSIONS							272265
	272266	272267	272268	272269	272270	272271	272272	
Overall Dimensions	w: 24"	24"	27"	30"	30"	36"	36"	Overall Dimensions
	h: 2"	2"	2"	2"	2"	2"	2"	w: 24"
	d: 39.5"	48"	57.5"	51.5"	63.5"	63.5"	75.5"	h: 41"
								d: 42"
Part #	272266	272267	272268	272269	272270	272271	272272	272265
Structural Capacity	NOT TO EXCEED 4,000 LBS							750 lbs
Platform W x L	24" x 36"	24" x 48"	27" x 54"	30" x 48"	30" x 60"	36" x 60"	36" x 72"	24" x 42"
Caster	chart selection	chart selection	chart selection	chart selection	chart selection	chart selection	chart selection	5" x 1.25" rubber
Weight	86 lbs	65 lbs	82 lbs	115 lbs	135 lbs	126 lbs	172 lbs	62 lbs

Actual capacity of assembled platform is dependent upon caster capacity but should never exceed the platform's structural capacity, regardless of caster type.

Caster Sets *Each Caster Set includes 2 rigid and 2 swivel casters.*

Extra Handles for Trucks with

Part #	Caster Sets								Extra Handles			
	272191	272192	272193	272194	272195	272201	272202	272203	272197	272198	272199	272200
Set Capacity	1,600 lbs	2,500 lbs	4,000 lbs	1,600 lbs	1,600 lbs	1,600 lbs	1,800 lbs	2,200 lbs	N/A	N/A	N/A	N/A
Description	6" x 1.375" Polyolefin	8" x 2" Polyolefin	8" x 2" Moldon Polyurethane on cast iron hub	8" x 2.5" Full Pneumatic	10" x 3.5" Full Pneumatic	5" x 2" Moldon Rubber on cast iron hub	6" x 2" Moldon Rubber on cast iron hub	8" x 2" Moldon Rubber on cast iron hub	N/A	N/A	N/A	N/A
"H" Dimension Floor to Platform Top	9"	11.5"	11.5"	12.25"	14.00"	8.5"	9.5"	12.5"	N/A	N/A	N/A	N/A
Caster Height	7"	9.5"	9.5"	10.25"	12"	6.5"	7.5"	10.25"	N/A	N/A	N/A	N/A
Weight	9 lbs	31 lbs	42 lbs	31 lbs	40 lbs	32 lbs	29 lbs	39 lbs	15 lbs	16 lbs	17 lbs	19 lbs

Actual capacity of assembled platform is dependent upon caster capacity but should never exceed the platform's structural capacity, regardless of caster type.

Power Drive Platform Truck

- 47¼" turning radius.
- Deck height from floor: 12.375".
- Finger tip variable speed controller with forward and reverse modes. Illuminated battery status indicator.
- Key lock and emergency stop.
- Motor: 370 watts.
- Maximum climbing incline: 8°.
- (2) 12v 40 A.H. batteries and charger included.
- Charge time: 7-8hr. / Continuous run time: 6 hr.
- Motor controller: Curtis 110 amp.
- Front wheels: 10" pneumatic.
- Rear swivel polyurethane casters: 5" x 2".
- Reverse direction safety beeper and reduced speed in reverse for added safety.
- Full perimeter bumper helps prevent wall damage.
- Rear panel grid helps keep cargo in place.
- Durable white powder coat finish with black rubber deck mat.
- 43" handle height.
- Steel thickness 2.5 mm.



Part #	OVERALL DIMENSIONS			
	w: 24" h: 43" d: 38.5"	24" 43" 50.5"	30" 43" 50.5"	30" 43" 62.5"
Capacity	880 lbs	880 lbs	880 lbs	880 lbs
Shelf Size	24" x 36"	24" x 48"	30" x 48"	30" x 60"
Wheel Type	10" Pneumatic	10" Pneumatic	10" Pneumatic	10" Pneumatic
Casters	5" x 2"	5" x 2"	5" x 2"	5" x 2"
Weight	243 lbs	254 lbs	276 lbs	300 lbs

Wood Dollies

- 4 swivel casters/3" hard rubber or 4" hard plastic.
- Seasoned hardwood with flush top bolted construction.
- Optional tow handle and eye hook.
- Ships KD and boxed via ground service.



**Optional Tow Handle and Eye Hook
Part #272073**



**Solid Platform
272055**



**Flush Open Deck
272058**



**Open Deck
Carpet Ends
272060**



**Open Deck
Rubber Ends
272062**

Description	Size	Part # 3" Casters	Part # 4" Casters
		(Weight / Capacity)	(Weight / Capacity)
Solid Platform	24" x 16"	272053 (18 lbs / 900 lbs)	272063 (20.5 lbs / 1,200 lbs)
	27" x 18"	272054 (20.5 lbs / 900 lbs)	272064 (23 lbs / 1,200 lbs)
	30" x 18"	272055 (23.5 lbs / 900 lbs)	272065 (26 lbs / 1,200 lbs)
	36" x 24"	272056 (32 lbs / 900 lbs)	272066 (34.5 lbs / 1,200 lbs)
Flush Open Deck	24" x 16"	272057 (14.5 lbs / 900 lbs)	272067 (17 lbs / 1,200 lbs)
	30" x 18"	272058 (16.5 lbs / 900 lbs)	272068 (19 lbs / 1,200 lbs)
	36" x 24"	272059 (21.5 lbs / 900 lbs)	272069 (24 lbs / 1,200 lbs)
Open Deck Carpet Ends	30" x 18"	272060 (16.5 lbs / 900 lbs)	272070 (19 lbs / 1,200 lbs)
	36" x 24"	272061 (18.5 lbs / 900 lbs)	272071 (21 lbs / 1,200 lbs)
Open Deck Rubber Ends	30" x 18"	272062 (18 lbs / 900 lbs)	272072 (20.5 lbs / 1,200 lbs)

Wire Caged Steel Platform Trucks

- Great for moving loose materials or small boxes.
- Two models, regular or heavy duty.
- Moldon non-marking TPR rubber wheels.
- Removable cages.
- Ships KD and boxed.
- Casters: two swivel, two rigid.



270456

OVERALL DIMENSIONS

w: 23"
h: 36"
d: 35"



270461

OVERALL DIMENSIONS

w: 30"
h: 40"
d: 48"

Commercial Quality Steel Panel Cart

- 8" Moldon non-marking TPR rubber wheels.
- Wraparound corner bumpers.
- Great for commercial applications.
- Casters: two swivel, two rigid.
- Removable side rails.



270388

OVERALL DIMENSIONS

w: 30"
h: 37"
d: 48"

Part #	270456	270461	270388
Capacity	660 lbs	1,100 lbs	1,100 lbs
Platform/ Deck Size	23" x 35"	30" x 48"	30" x 48"
Handle Height	36"	40"	37"
Deck Height	8.5"	11.5"	11.5"
Caster Size	5" x 2"	5" x 2"	8" x 2"
Weight	66 lbs	124 lbs	118 lbs

U-boats

- 8 models and a variety of sizes to suit your application.
- Painted steel, galvanized steel, aluminum, wood deck models available.
- Tilting and non-tilting models.
- Removable handles, except on folding handle model.
- 2 rigid center casters and 4 swivel end casters allow trucks to turn on their own radius. Provides easy maneuverability in narrow aisles and confined areas.
- **#273565 galvanized steel shelf option for #273291 U-boat only (16"W x 60"L).** 350 lb. maximum capacity with evenly distributed load.

*#273291 U-boat can handle two shelves.



273565
*Steel Shelf Option for 273291



273292
Zinc Plated



273296 - Aluminum
Folding Handles



273291
Zinc Plated



270339
Aluminum



273295
Zinc Plated

OVERALL DIMENSIONS

w:	16"	16"	16"	18"	24"
h:	61"	61"	60"	60"	60"
d:	64"	63"	63"	63"	63"

Part Number	273296	270339	273291	273292	273295
Capacity	1,750 lbs	1,322 lbs	1,750 lbs	1,750 lbs	1,750 lbs
Platform (W x L)	16" x 59.5"	16" x 63"	16" x 60"	18" x 60"	24" x 60"
Material	Aluminum	Aluminum	Zinc Plated	Zinc Plated	Zinc Plated
Deck Type	Open	Open	Tread plate	Tread plate	Tread plate
Tilting	Yes	Yes	No	No	Yes
2 Rigid Wheels (center)	6" x 2" Polyurethane	6" x 2" Polyurethane	8" x 2" Polyurethane	8" x 2" Polyurethane	8" x 2" Polyurethane
4 Swivel Casters (ends)	5" x 1.25" Polyurethane	5" x 1.25" Polyurethane	4" x 1.25" Polyurethane	4" x 1.25" Polyurethane	4" x 1.25" Polyurethane
Deck (h) (at center)	9.5"	9.5"	10.75"	10.75"	10.75"
Height - Handle top	62"	61"	60"	60"	53.25"
Weight (lbs.)	63.5 lbs	91 lbs	97 lbs	109 lbs	116.5 lbs

Steel Folding Handle Trucks

- Fold down handle for easy storage.
- Enameled finish with non-skid heavy vinyl deck surface.
- Protective vinyl perimeter bumpers.
- 4" & 5" caster wheels TPR non-marking rubber.
- Boxed and UPS shippable.

TWO MODELS:
Deluxe - Best quality truck on the market.
Economy - For the price-conscious buyer



Telescoping Handle Platform Trucks

- Same high quality as our Deluxe Series folding handle platform trucks.
- With the push of a lever, the handle telescopes up or down.
- 4 position handle height adjustment provides stops at 32", 37", 41" and 44".
- Comfortably accommodates a wide range of user heights. Also acts as a support for taller loads.
- Handle folds down for storage or easy transport in car trunk.
- Boxed and UPS shippable.



Stainless Steel Folding Handle Truck

- Fold down handle for easy storage.
- Caster: sealed bearing with stainless rig.
- TPR rubber non-marking caster wheels.
- Vinyl perimeter bumper.
- Boxed and UPS shippable.

ALL STAINLESS STEEL: Handle, Platform and Caster Rigs



	OVERALL DIMENSIONS			OVERALL DIMENSIONS			OVERALL DIMENSIONS		OVERALL DIMENSIONS	
	w: 19"	23"	23"	w: 19"	23"	23"	w: 19"	23"	w: 19"	22.5"
	h: 32.5"	37.5"	43.5"	h: 32.5"	32.5"	38.5"	h: 32"- 44"	32"- 44"	h: 34.5"	34"
	d: 29"	35"	35"	d: 29"	35"	35"	d: 29"	35"	d: 29"	34"
Part # Model #	272019 Deluxe	272035 Deluxe	272235 Deluxe	272238 Economy	272239 Economy	278762 Economy	272262 Deluxe	272263 Deluxe	270457 Deluxe	270458 Deluxe
Capacity	440 lbs	660 lbs	660 lbs	275 lbs	400 lbs	400 lbs	440 lbs	660 lbs	440 lbs	770 lbs
Platform Size	19" x 29"	23" x 35"	23" x 35"	19" x 29"	23" x 35"	23" x 35"	19" x 29"	23" x 35"	19" x 29"	22.5" x 34"
Caster Size	4"	5"	8" Pneumatic	4"	5"	8" Pneumatic	4"	5"	2 swivel/2 rigid	2 swivel/2 rigid
Handle Height	32.5"	37.5"	43.5"	32.5"	32.5"	38.5"	32"- 44"	32"- 44"	4" Stainless Rigs	5" Stainless Rigs
Weight	28 lbs	47 lbs	69.7 lbs	21 lbs	41 lbs	69 lbs	27 lbs	43 lbs	26 lbs	37 lbs

Aluminum Folding Ergo-Handle Truck

- Ergonomic European style handle.
- Corner bumpers.
- Boxed and UPS shippable.



OVERALL DIMENSIONS

w: 24"
h: 41"
d: 35.5"

Aluminum Folding Handle Truck

- TPR rubber non-marking caster wheels.
- Lightweight aluminum deck.
- Wrap around corner bumper.
- Boxed and UPS shippable.



OVERALL DIMENSIONS

w: 18.5" 24"
h: 34.5" 35.5"
d: 29" 35.5"

Aluminum Folding Handle Long Deck Truck

- TPR rubber non-marking caster wheels.
- Lightweight aluminum deck.
- Wrap around corner bumper.
- Six 5" casters, four swivel on ends, two rigid in center.
- Boxed and UPS shippable.



OVERALL DIMENSIONS

w: 18.5"
h: 35.5"
d: 58.5"

Aluminum Professional Series Telefolding Truck

- Deck extends from 21" to 29.5".
- Push button, quick conversion.
- Anti-impact, non-skid polypropylene and aluminum deck.
- Non-marking 4" moldon rubber wheels.
- Sponge rubber coated handle.
- Boxed and UPS shippable.

OVERALL DIMENSIONS

w: 17.5"
h: 36.5"
d: 21"-29.5"



Aluminum Economy Telefolding Truck

- Deck extends from 20" to 28".
- Full size platform truck that folds to briefcase size.
- Strong, lightweight aluminum frame.
- Protective vinyl corner bumpers.
- Boxed and UPS shippable.
- Rubber wheel with plastic hub.
- Swivel casters with brake.

OVERALL DIMENSIONS

w: 16"
h: 36.5"
d: 20"-28"



Part #	270382	272076	272112	270389	272048	272250
Capacity	660 lbs	350 lbs	550 lbs	660 lbs	330 lbs	300 lbs
Platform W x L	24" x 35.5"	18.5" x 29"	24" x 35.5"	18.5" x 58.5"	17.5" x 21" - 29.5"	16" x 20" - 28"
Handle Height	41"	34.5"	35.5"	35.5"	36.5"	37.75"
Caster Size	7" 2 swivel/2 rigid	4" 2 swivel/2 rigid	5" 2 swivel/2 rigid	5" 4 swivel/2 rigid	4" 2 swivel/2 rigid	4" 2 swivel w/brake/2 rigid
Weight	46 lbs	26 lbs	33 lbs	44 lbs	19 lbs	21 lbs



260290



260292



260291



260293



260294

Stainless Steel Carts

- 430 Stainless Steel shelf and frame construction.
- NSF Approved.
- 4 swivel, zinc plated casters with non-marking rubber tread polyurethane hub wheels.
- 3 shelves
 - .040" thick
 - top and center 1" lip, 3 sides
 - bottom flat, no lip.
- Sound deadening aluminum pad on underside of top shelf.
- Welded construction.
- Protection bumpers on legs and handle.
- Shelves have reinforced hemmed front.
- *Overall capacity based upon evenly distributed loads.**



OVERALL DIMENSIONS

w:	27.5"	30.75"	27.625"	31"	39.25"
h:	32.125"	33"	32"	32"	37.25"
d:	16.25"	18.375"	16.75"	19"	22.375"

Part # Model #	260290 SS3C11	260291 SS3C22	260292 SS4C11	260293 SS4C22	260294 SS4C44
Overall Capacity	300 lbs	300 lbs	500 lbs	500 lbs	500 lbs
Shelf	100 lbs Cap.*	100 lbs Cap.*	166 lbs Cap.*	166 lbs Cap.*	166 lbs Cap.*
Shelf Size (L x W)	24" x 15.5"	27.125" x 17.625"	24" x 15.75"	27.375" x 18"	35.125" x 21"
Shelf Lip Height	1"	1"	1"	1"	1"
Distance Between Shelves	12.75"	13.25"	12.5" top/14.625" bottom	13" top/14.5" bottom	14.375" top/14.5" bottom
Caster Wheel	3.5" dia. .75" w	3.5" dia. .75" w	4" dia. .75" w	4" dia. .75" w	5" dia. 1.25" w
Weight	30.5 lbs	40 lbs	36 lbs	42 lbs	67 lbs

Deluxe Plastic Service Cart

- 550 lb. capacity, evenly distributed load.
- Available in two sizes: 16" x 30" and 24" x 36".
- Optional 3rd shelf.
- Heavy duty construction resists chips, dents, and rust.
- Push handle has compartments to accommodate a variety of tools, labels, small parts, etc.
- Shipped KD, boxed, and includes 5" non-marking casters - 2 swivel, 2 rigid.
- Caster wheels; 5" TPR (thermoplastic rubber tread) molded onto polypropylene hub.
- Shelf depth 2.625".



270434



270434 cart with 270454 3rd tray

OVERALL DIMENSIONS

w:	16.5"	16.5"	25"	25"
h:	33.5"	4.125"	35.5"	4.125"
d:	37.5"	31"	43.5"	37.25"

Standard Plastic Service Cart

- 500 lb. maximum capacity, evenly distributed load.
- Available in two sizes: 16" x 30" and 24" x 36".
- Optional 3rd shelf.
- Shipped KD, boxed, and includes 5" non-marking casters - 2 swivel, 2 rigid.
- Caster wheels; 5" TPR (thermoplastic rubber tread) molded onto polypropylene hub.
- Very economical.
- Shelf depth 2.625".



270482



270483



270493
Flat Work Surface

OVERALL DIMENSIONS

w:	17.375"	17.375"	25.5"	25.5"	25.5"
h:	32.5"	4.125"	32.5"	4.125"	32.5"
d:	34.25"	34.25"	40.25"	40.25"	40.25"

Part # Model #	270433 DPC-1630	270453 DES-1630	270434 DPC-2436	270454 DES-2436	270482 SD-1630	270484 SDES-1630	270483 SD-2436	270485 SDES-2436	270493 SDF-2436
Capacity	550 lbs	N/A	550 lbs	N/A	500 lbs	N/A	500 lbs	N/A	500 lbs
No. of trays	2	Optional	2	Optional	2	Optional	2	Optional	2
Description	Service cart	3rd tray	Service cart	3rd tray	Cart	3rd tray	Cart	3rd tray	<i>Flat top cart</i>
Dimensions	16" x 30"	16" x 30"	24" x 36"	24" x 36"	16" x 30"	16" x 30"	24" x 36"	24" x 36"	25.5" x 34"
Weight	37 lbs	9 lbs	50 lbs	13 lbs	36 lbs	9 lbs	49 lbs	13 lbs	43 lbs

Economy Plastic Service Cart

- 330 lb. maximum capacity, evenly distributed load.
- Optional 3rd shelf.
- Shipped KD, boxed, and includes 5" non-marking casters - 2 swivel, 2 rigid.
- Value priced.
- Caster wheels; 5" TPR (thermoplastic rubber tread) molded onto polypropylene hub.
- Shelf depth 2".



OVERALL DIMENSIONS

w:	17.25"	17.25"
h:	30.635"	3.125"
d:	34"	34"

Part # Model #	270494 EPC-1630	270496 EES-1630
Capacity	330 lbs	N/A
No. of Trays	2	Optional
Description	Cart	3rd tray
Dimensions	16" x 30"	16" x 30"
Weight	36 lbs	9 lbs

Value Plastic Platform Trucks

- Economically priced.
- Fixed and folding handle designs.
- Plastic platform with steel handle.
- Steel reinforced platform.
- Platform height - 8".



272281



OVERALL DIMENSIONS

w:	19"	22"
h:	34.5"	34.5"
d:	27.5"	33.5"

Part #	272281	272282	272946
Capacity	265 lbs	265 lbs	400 lbs
Folded (H x W x D)	N/A	N/A	2.5" x 20" x 34"
Wheel Size	5" x 1" rubber caster	5" x 1" rubber caster	5" swivel caster
Platform W x D	19.25" x 22.25"	22" x 30.5"	20" x 31"
Handle Type	34.5" fixed	34.5" fixed	37.5" folding
Construction	Plastic	Plastic	Polyurethane
Weight	20 lbs	26.5 lbs	24 lbs

Bi-Mode Poly Folding Handle Truck

- *Push/Pull mode* - handle is tilted allowing truck to be pulled or pushed.
- *Dolly mode* - handle folds flush with surface of deck allowing truck to be used as a dolly without cargo coming in contact with handle. Cargo stays flat and secure on deck.
- Casters— two swivel, two rigid 5" non-marking rubber wheels.

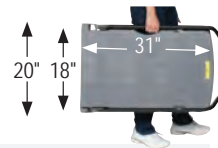

272946

Wire Office Carts

- Ideal for carrying hanging files (letter and legal) mail, packages and tools.
- Swivel casters.
- Removable baskets.
- 1" diameter, 18 gauge tubular construction.
- All metal surfaces plated for long life.
- Shipped KD and boxed via UPS.



272228
Standard Compact Office Cart

OVERALL DIMENSIONS

w: 20"
h: 37.5"
d: 33"



272230
Deluxe Compact Office Cart

OVERALL DIMENSIONS

w: 23.75"
h: 38.25"
d: 33.5"



272231
Deluxe Large Office Cart

OVERALL DIMENSIONS

w: 23.75"
h: 38.5"
d: 43"

Foldaway Table Top Cart

- Folds for easy storage.
- Ideal for transporting instruments and office equipment.
- Laminate surface with vinyl edge.
- Four 4" swivel ball bearing casters.
- Lower basket: 21" x 13".



272233

OVERALL DIMENSIONS

w: 19"
h: 28.75"
d: 28"

Office Caddy

- Multi-purpose service truck ideal for offices and service vehicles.
- Fits in most car trunks.
- Easily converts for use as a four wheel rolling table or two or four wheel hand truck. 7 possible positions.
- Oak color top with vinyl edge.
- 8" x 1.75" easy roll semi-pneumatic wheels and 2.5" hard rubber swivel casters.

OVERALL DIMENSIONS

w: 19"
h: 55"
d: 18"



Part #	272228	272230	272231	272233
Capacity	200 lbs	200 lbs	250 lbs	200 lbs
Basket/Table Size	25" x 17.25" x 11"	25 x 17.25" x 11"	36 x 17.25" X 11"	28" x 19"
Lower Basket	25" x 17.25" x 7.5"	25 x 17.25" x 7.5"	36 x 17.25" X 7.5"	N/A
Handle Height	N/A	N/A	N/A	N/A
Deck Height	N/A	N/A	N/A	28.75"
Collapsed Size	N/A	N/A	N/A	6"
Raised Height	N/A	N/A	N/A	N/A
Lowered Height	N/A	N/A	N/A	N/A
Caster Size	4" hard rubber	5" hard rubber	5" hard rubber	4"
Wheel Size	4" hard rubber	10" semi-pneumatic	10" semi-pneumatic	N/A
Weight	41 lbs	49 lbs	62 lbs	32 lbs

Mega Mover, Maxi Mover, Superlite & Mini Mover Folding Trucks

- Space saving folding design. Fits into small storage spaces or car trunks.
- Elastic straps for securing load.
- Aluminum or steel construction.
- **Non-marking wheels.**
- Mini Mover fits into overhead airline compartments.

220646



WESCO® lightweight folding trucks



SIZE COMPARISON

**Mega Mover
220650**

**Maxi Mover
220649**

**SuperLite
220617**

**Mini Mover
220646**

OVERALL DIMENSIONS EXTENDED

w: 26.5"
h: 47"
d: 25.5"

19"
42"
19"

19"
42"
19"

15.5"
41"
17.5"

Part #	220650	220649	220617	220646
Capacity	550 lbs	275 lbs	175 lbs	110 lbs
Folded (H x W x D)	34" x 23.5" x 4.75"	29.5" x 19" x 2"	29.5" x 19" x 2"	24" x 15.25" x 2"
Wheel Size	8" x 2.5" pneumatic wheel	7" x 1.5" rubber tread / poly hub	7" x 1.5" rubber tread / poly hub	5" x 1.25" rubber tread / poly hub
Noseplate/Platform Dimensions (W x D)	23.5" x 18" Noseplate	19" x 12" Noseplate	19" x 12" Noseplate	15" x 12.5" Noseplate
Handle Type	34" - 47"	29.5" - 42"	29.5" - 42"	24" - 41"
Construction	Aluminum	Steel	Aluminum	Aluminum
Weight	33 lbs	14 lbs	11.5 lbs	9 lbs

Tilt Carts

- Heavy-duty, molded, FDA compliant material, polyethylene bin.
- Easy to move and dump.
- Wheels: 10" x 2.75" / 12" x 3" black rubber tread tire, molded to polyolefin hub.
- Swivel casters, polyurethane wheels.
- 1/2 and 1 cubic yard bins.

- All models include bin, frame, handle, wheels and casters.
- Optional black polyethylene hinged lids: #272586 - 1/2 cu. yd. and #272587 - 1 cu. yd. (304 stainless hinge).
- Four grades: utility, standard, heavy duty and forklift.
- **Blue recycle** 1/2 cubic yard bin available: #272577.



Fork Pocket



272575 Utility



272583 Standard



272577 Standard/Recycle

Overall Height

Part # Model #	272575 1/2 U450B	272576 1/2 S850B	272577 1/2 S850BLRC	272578 1/2 S850R	272579 1/2 HD1400B	272580 1/2 FL850B	272581 1U850B	272582 1S1250B	272583 1S1250R	272584 1HD2100B	272585 1FL1250B
Type	Utility	Standard	Standard/Recycle	Standard	Heavy Duty	Fork Lift	Utility	Standard	Standard	Heavy Duty	Fork Lift
Cubic Yard	1/2	1/2	1/2	1/2	1/2	1/2	1	1	1	1	1
Capacity	450 lbs	850 lbs	850 lbs	850 lbs	1,400 lbs	850 lbs	850 lbs	1,250 lbs	1,250 lbs	2,100 lbs	1,250 lbs
Color	Black	Black	Blue	Red	Black	Black	Black	Black	Red	Black	Black
Wheel	10" x 2.75"	10" x 2.75"	10" x 2.75"	10" x 2.75"	12" x 3"	12" x 3"	10" x 2.75"	12" x 3"	12" x 3"	12" x 3"	12" x 3"
Caster	(2) 4" x 1.5"	(2) 3" x 1.25"	(2) 3" x 1.25"	(2) 3" x 1.25"	(2) 4" x 2"	(1) 4" x 2"	(2) 4" x 1.25"	(2) 4" x 1.25"	(2) 4" x 1.25"	(2) 4" x 2"	(2) 4" x 2"
DIMENSIONS											
A,B	60.75", 57"	61.5", 57"	61.5", 57"	61.5", 57"	61.5", 57"	61.5", 57"	72.5", 69"	72.75", 69"	72.75", 69"	72.75", 69"	73.75", 69"
C,D	21.5", 26.5"	21.5", 26.5"	21.5", 26.5"	21.5", 26.5"	21.5", 26.5"	21.5", 27"	24.5", 29.25"	24.5", 29.25"	24.5", 29.25"	24.5", 29.25"	24.5", 29.25"
E,F	18.75", 16"	18.75", 16"	18.75", 16"	18.75", 16"	18.75", 16"	18.75", 16"	22", 19.25"	22", 19.25"	22", 19.25"	22", 19.25"	22.5", 19.25"
G,H	29", 31"	29", 31"	29", 31"	29", 31"	29", 31"	29", 31"	37", 37"	37", 37"	37", 37"	37", 37"	37", 37"
Overall Height	36.5"	36.5"	36.5"	36.5"	37.5"	37.25"	43"	43"	43"	43.25"	43.5"
Weight	51 lbs	65.5 lbs	65.5 lbs	65.5 lbs	83.5 lbs	88 lbs	74 lbs	94.5 lbs	94.5 lbs	107.5 lbs	119 lbs



1/2 and 1 Cubic Yard Lids

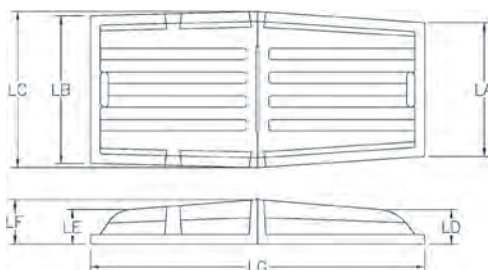

Lid Part #	272586	272587
Size	1/2 Cu. Yd.	1 Cu. Yd.
LA, LB, LC	24", 26.5", 28.375"	27.125", 29", 33.125"
LD, LE, LF, LG	6.5", 6.25", 7.5", 61"	6.625", 6.625", 8.25", 71.50
Weight	11 lbs.	16.5 lbs



Plastic Box Trucks

- Material: polyethylene.
- Five sizes and color choices.
- Two caster choices: 5" Polyurethane or 8" Pneumatic. Two swivel, two rigid mounted on 5-Ply Plywood base for extra rigidity (except 4 bushel models).
- Can ship KD and nested on quantity orders.
- Caster pattern Standard or Diamond.
- **White color, only, produced from FDA compliant polyethylene material.***

**Standard
Caster
Pattern**

OR

**Diamond
Caster
Pattern**

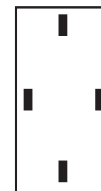
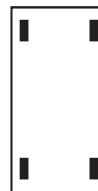

To order the diamond caster pattern, add DP to Part #. Example: 272513DP.



272527



272524



272548



**Look!
8" Pneumatic Casters**

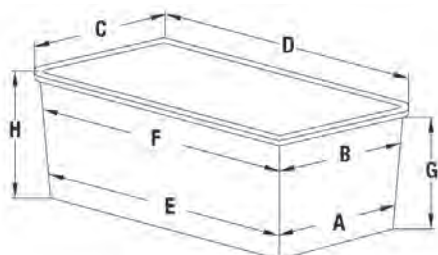

**5" caster adds 6.75" to height, except 4 bushel adds 6"
8" caster adds 10.75" to height, except 4 bushel adds 10"**

Volume	32 gal. 4 bushels	64 gal. 8 bushels	96 gal. 12 bushels	128 gal. 16 bushels	160 gal. 20 bushels
Capacity	350 lbs	450 lbs	550 lbs	600 lbs	600 lbs
Dimensions (inches): A-B-C-D E-F-G-H	17 - 17.75 - 20.75 - 32 27.75 - 29 - 13.75 - 15.25	19 - 21 - 24 - 35 30 - 31.75 - 21.5 - 23	22.75 - 25 - 28 - 38 33 - 35 - 27 - 28.25	24.25 - 27 - 30 - 42 36 - 38 - 28.25 - 29.75	28 - 30.75 - 34 - 46 39.75 - 43 - 31.25 - 33
Weight: Tub Only	10 lbs	16.5 lbs	25 lbs	33 lbs	42.5 lbs
Weight: Assembled Tub					
5" Caster	20 lbs	43 lbs	50 lbs	54 lbs	65 lbs
8" Caster	24 lbs	47 lbs	54 lbs	58 lbs	69 lbs
GREY Part #: 5" Caster	272503	272508	272513	272518	272523
8" Caster	272530	272531	272532	272533	272534
BLUE Part #: 5" Caster	272504	272509	272514	272519	272524
8" Caster	272535	272536	272537	272538	272539
* WHITE Part #: 5" Caster	272505	272510	272515	272520	272525
8" Caster	272540	272541	272542	272543	272544
RED Part #: 5" Caster	272506	272511	272516	272521	272526
8" Caster	272545	272546	272547	272548	272549
YELLOW Part #: 5" Caster	272507	272512	272517	272522	272527
8" Caster	272550	272551	272552	272553	272554



Dock Seals

- 40 oz high-tear-abrasion-resistant fabrics
- Double lock stitched seams
- Kiln dried superior grade backing lumber
- 99% Memory Foam core for extended life
- Fixed head pad provides maximum seal
- Condensation drainage system
- Full height yellow guide strips
- Galvanized mounting hardware included
- 10" and 20" projections - standard (Call for more options.)
- Models available with replaceable wear pleats
- Blue, green or brown color options available



Heavy Duty Standard 40 OZ
w/Optional Wear Pleats - 8' x 8', 10" Projection
Part #276056



Heavy Duty Standard 40 OZ
8' x 8', 10" Projection
Part #276050



Heavy Duty Standard 40 OZ
w/Top Curtain and Optional Wear Pleats
8' x 10', 10" Projection - Part #276060

CALL US WITH YOUR SPECIFICATIONS!

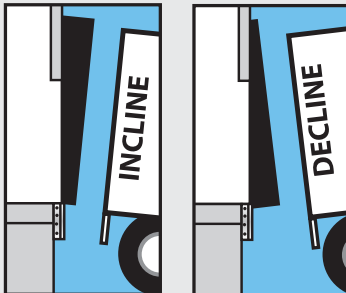

Tapered Units for Incline/Decline
Approach are Available

Let Wesco's team of professionals assist you with custom sizes and features. Blue, green or brown color options are available, as well.

Part # Model #	276050 DS-9696-10	276051 DS-9696-20	276052 DS-96108-10	276053 DS-96108-20	276054 DS-96120-10	276055 DS-96120-20
Description	Heavy Duty 40 oz.	Heavy Duty 40 oz.	Heavy Duty 40 oz.	Heavy Duty 40 oz.	Heavy Duty 40 oz.	Heavy Duty 40 oz.
Door Width	8'	8'	8'	8'	8'	8'
Door Height	8'	8'	9'	9'	10'	10'
Projection	10"	20"	10"	20"	10"	20"
Weight	280 lbs	300 lbs	280 lbs	300 lbs	280 lbs	300 lbs
Part # Model #	276056 DS-9696-10-P	276057 DS-9696-20-P	276058 DS-96108-10-P	276059 DS-96108-20-P	276060 DS-96120-10-P	276061 DS-96120-20-P
Description	w/Wear Pleats	w/Wear Pleats	w/Wear Pleats	w/Wear Pleats	w/Wear Pleats	w/Wear Pleats
Door Width	8'	8'	8'	8'	8'	8'
Door Height	8'	8'	9'	9'	10'	10'
Projection	10"	20"	10"	20"	10"	20"
Weight	280 lbs	300 lbs	280 lbs	300 lbs	280 lbs	300 lbs

UL Approved Dock Lights

- Spring-loaded pushup socket for easy bulb changing.
- 7 gauge wall mount standard.
- 18" two speed fan accessory.
- Use with incandescent lamps or LED only: PAR-38: up to 150W. R40: up to 300W.
- For indoor use.
- Ready for hardwiring or plug attachment.
- 272328 & 272329 arm and fan only (NO LIGHT). Fan has a 62" long cord with a 3 prong plug. Fan plugs directly into outlet. No hard wiring or plug attachment required. On & Off switch on fan.



Part #	272224	272240	272260	272290	272330	272328	272329	272340	272360
Description	24" Light	40" Light	60" Light	90" Light	Fan only	Fan with 40" arm	Fan with 60" arm	Light & fan w/40" arm	Light & fan w/60" arm
Weight	15.5 lbs	17.7 lbs	22 lbs	31 lbs	20 lbs	41 lbs	45 lbs	38 lbs	39 lbs

Universal Strapping Truck

- Automatic brake to reduce strap spillage.
- Tray for storing tools and seals.
- Handles steel and non-metallic strapping.
- Accepts 3", 6" and 8" face coils; 8" and 16" core sizes.
- 10" x 1.75" steel semi-pneumatic wheel.



272286

OVERALL DIMENSIONS

w: 27"
h: 39"
d: 25"

Poly Strapping System

- Tools for tightening and sealing poly and plastic strap.
- High quality tensioner tightens and cuts .5" to .625" plastic strap.



BOXED OVERALL DIMENSIONS

w: 4.25"	4.25"	4.25"
h: 3"	1.5"	1.5"
d: 10.75"	17"	17"

Steel Strapping System

- Tools for tightening and sealing steel banding.
- Cast steel tensioner for most sizes (.375" to .75").

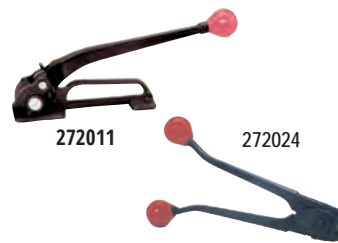

BOXED OVERALL DIMENSIONS

w: 4"	6.25"	6.25"	6.25"
h: 3.5"	1.75"	1.75"	1.75"
d: 15.5"	13.5"	13.5"	13.5"

Strap Cutters

- One hand operation.

OVERALL DIMENSIONS

w: 1.75"
h: 1.75"
d: 12"



Part #	272286	272008	272009	272010	272011	272023	272024	272025	272015
Description	Truck	Tensioner	Sealer	Sealer	Tensioner	Sealer	Sealer	Sealer	Deluxe
Size	N/A	.375" - .75"	.5" only	.625" only	.375" - .75"	.375" only	.5" only	.75" only	up to .75"
Weight	54 lbs	3 lbs	4 lbs	4 lbs	5 lbs	2 lbs	2 lbs	2 lbs	2 lbs

Trailer Stabilizing Jacks

- High strength steel construction.
- Adjustable height for leveling of trailers parked on uneven ground.
- Broad base prevents trailer dollies from sinking into soft surfaces.
- Prevents up-ending of semi-trailers when not connected to a truck during loading/unloading..
- **TSJE Economy**, manually turned ACME threaded screw raises and lowers jack. 14" dia. base, 5" x 5" top plate.
- **TSJS Standard**, ratchet with ACME threaded screw raises and lowers jack. 14" diameter x 1/2" thick base plate, 8" semi-pneumatic wheels. 8" diameter top plate.
- **TSJHD Heavy duty**, two way reversible hand ratchet, 6" x 24" long beam, 5" triangular base, 8" semi-pneumatic wheels, and 4" semi-steel wheels.
- Wesco recommends always using at least two jacks per trailer. Meets OSHA requirements.



272957

OVERALL DIMENSIONS

w: 13.75"
h: 44"-51"
d: 12.75"



272955

OVERALL DIMENSIONS

w: 13.75"
h: 39.5"-51"
d: 13.75"



272956

OVERALL DIMENSIONS

w: 14.5"
h: 39.5"-51"
d: 26.5"

Part # Model #	272957 TSJE	272955 TSJS	272956 TSJHD
Static Capacity	50,000 lbs	100,000 lbs	100,000 lbs
Lifting Capacity	5,000 lbs	40,000 lbs	50,000 lbs
Service Range	44" - 51"	39.5" - 51"	39.5" - 51"
Weight	45 lbs	125 lbs	160 lbs

Battery Transfer Cart

- For use with a standard pallet truck (sold separately).
- Pallet trucks easily locate in 6.75" W x 3.5" H fork pockets.
- One person can easily remove and replace forklift batteries.
- (12) 2.25" diameter steel rollers.
- Swing tabs help to hold battery in place while on rollers.
- Winch with 2" wide nylon belt and safety latch hook.
- Height to top of rollers 6.5".
- Platform roller base:
I.D. 26.75" W x 43.25" L.
O.D. 27.25" W x 43.625" L.
- Adjustable winch height:
Lowered - 29.625".
Raised - 35.50".

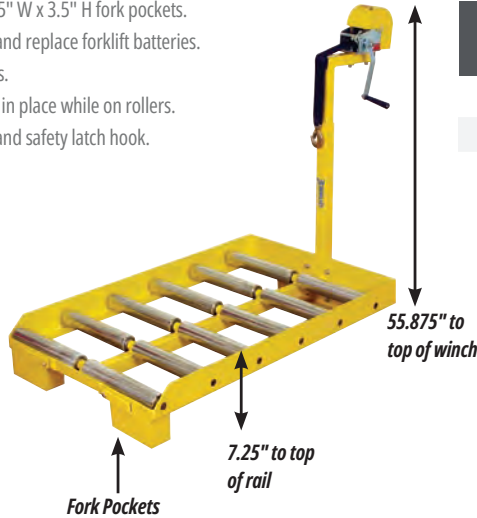

Part #	274260
Model #	BAT-TC
Capacity	4,000 lbs
W x L	26.75" W x 43.25" L (usable deck)
Weight	131 lbs

OVERALL DIMENSIONS

w: 27.25"
h: 41.50"
d: 55.875"

Fork Extensions

- Heavy duty welded steel construction.
- Steel restraining strap prevents extensions from sliding off fork.
- Sold in pairs.
- Maximum lift truck fork thickness 2".

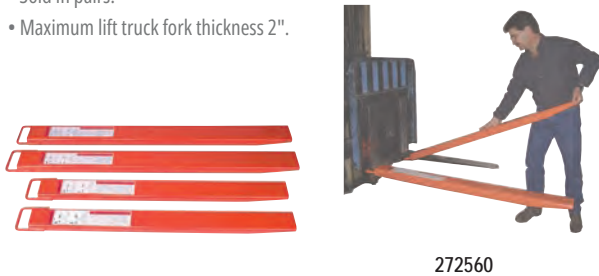

OVERALL DIMENSIONS					
w:	6.75"	6.75"	7.75"	7.75"	8.75"
h:	2.375"	2.375"	2.375"	2.375"	2.375"
d:	63.375"	75.375"	63.375"	75.375"	75.375"

Part #	272558	272559	272560	272561	272562
Capacity	N/A	N/A	N/A	N/A	N/A
Size	4" x 60"	4" x 72"	5" x 60"	5" x 72"	6" x 72"
Fits Fork Width	4"	4"	5"	5"	6"
Weight	95 lbs	114 lbs	108 lbs	121 lbs	139 lbs

NOTES:

1. OSHA requires contacting the manufacturer of your fork truck for written approval for the use of any fork truck attachment.
2. OSHA standards require that the length of fork extensions do not exceed the lift truck fork length by more than 50%. (e.g., Fork extension used on 48" long lift truck forks should not exceed 72".)
3. The use of extensions effect lift truck capacity. Contact lift truck manufacturer for load capacity reductions.

Foldable Maintenance Platform

- (4) swivel casters - 4" x 1.5" moldon polyurethane.
- Comes with (2) swivel casters and (2) swivel locking casters
- Fork Pockets: 7.75"W x 3.5"H. Centers: 26".
- Replacement **caster set #272572**, 13.2 lbs.



Part #	272571
Capacity	600 lbs
Size	Platform Deck - 37" x 37" I.D.
Fits Fork Width	N/A
Weight	220 lbs

OVERALL DIMENSIONS

w: 37.5"
h: 81" w/o casters; 87.25" w/casters
d: 42.25"

Part No.	Model	Diameter	Hub Type	Tread Width	Hub Length	Bore Id	Approx. Weight	Bearing Type	Capacity Lbs.
Cellular Foam Wheel (Microcellular Polyurethane will not go flat.)									
053446	CF	10"	Steel	3"	2.25"	.625"	5 LBS.	BALL	280
053490	CFB	10"	Steel	3"	2.25"	.75"	5 LBS.	BALL	280
Solid Rubber Wheels									
150698	Z2	10"	Poly	2.75"	2.25"	.625"	5 LBS. 12 OZ.	BALL	550
150697	Z8	8"	Poly	2.0"	2.25"	.625"	3.5 LBS.	BALL	300
108479	SR	10"	Poly	2.5"	2.25"	.625"	9 LBS.	BALL	250
109486	Z-12	12"	Poly	3"	3.25"	.625"	8 LBS.	BALL	750
Semi-Pneumatic Wheels									
052859	Z8B	8"	Poly	2.5"	2"	.75"	4.25 Lbs.	Ball	250
150589	Z	10"	Zinc/Steel	2.75"	2.25"	.625"	6.25 Lbs.	Ball	350
Pneumatic Wheels									
050602	P	10"	Zinc/Steel	3.50"	2.25"	.625"	4 LBS.	BALL	350
108478	PB	10"	Zinc/Steel	3.50"	2.25"	.75"	4 LBS.	BALL	350
108484	P-12	12"	Zinc/Steel	4"	3.25"	.75"	7 LBS.	BALL	460
151507	PWT	10"	Zinc/Steel	3.625"	2.25"	.625"	4 LBS.	BALL	350
151551	PE	10"	Zinc/Steel	3.50"	2.25"	.625"	3.5 LBS.	BALL	350
Aluminum Center Moldon Rubber Wheels									
050567	A	6"	Solid	2"	2.375"	.625"	2.5 LBS.	BALL	500
053706	AB	6"	Solid	2"	2.1875"	.625"	2.5 LBS.	ROLLER	500
053707	-	6"	Solid	2"	2.1875"	.75"	2.5 LBS.	ROLLER	500
052870	RB	8"	Solid	1.625"	2"	.75"	3 LBS.	BALL	500
108545	R	8"	Solid	1.625"	2"	.625"	3 LBS.	BALL	500
052868	H-1B	8"	Solid	2"	2.25"	.75"	3.75 LBS.	BALL	550
053708	H-1R	8"	Solid	2"	2.1875"	.625"	3.75 LBS.	ROLLER	600
150131	H-1RB	8"	Solid	2"	2.1875"	.75"	3.75 LBS.	ROLLER	600
108561	R3	8"	Spoke	1.625"	1.625"	.625"	2.5 LBS.	BALL	300
Balloon Cushion Wheels									
*150228	BC-10	10"	Poly	2.165"	2.25"	.625"	4 LBS. 12 OZ.	BALL	300
*150229	BC-8	8"	Poly	2.165"	2.25"	.625"	2 LBS. 12 OZ.	BALL	300
050566	RK-8	8"	Poly	2.25"	2.25"	.750"	3 LBS. 10 OZ.	BALL	450
Cast Iron Center Moldon Rubber Wheels									
053722	-	5"	Iron	2"	2.1875"	.75"	3.25 LBS.	ROLLER	500
108838	-	6"	Iron	1.5"	2"	.75"	3.50 LBS.	BALL	400
108839	-	6"	Iron	1.5"	2"	.625"	3.50 LBS.	BALL	400
053723	-	6"	Iron	2"	2.1875"	.625"	4.25 LBS.	ROLLER	500
053724	-	6"	Iron	2"	2.1875"	.75"	4.25 LBS.	ROLLER	500
050579	H	8"	Iron	2"	2.1875"	.625"	6.25 LBS.	ROLLER	600
150120	HB	8"	Iron	2"	2.1875"	.75"	6.25 LBS.	ROLLER	600
150596	BT	10"	Iron	2.5"	2.75"	1.00"	13.75 LBS.	ROLLER	800
Moldon Polyurethane on Polypropylene Hub									
053730	PP10	10"	Poly	2.5"	2.75"	1.00"	6 LBS.	ROLLER	1200
053733	PP8	8"	Poly	2"	2.1875"	.75"	2.5 LBS.	BALL	800
Polyolefin Center Moldon Rubber Wheel									
150692	R2	8"	Poly	1.625"	2.187"	.625"	1 LB.	PLAIN	375
Solid Polyolefin Wheels									
150103	CWP-1	2.5"	Poly	1.125"	1.25"	.5"	2.5 OZ.	PLAIN	200
150197	-	3"	Poly	1.25"	1.56"	.375"	3 OZ.	PLAIN	300
101355	-	4"	Poly	1.25"	1.56"	.5"	5 OZ.	PLAIN	350
108300	CT-3	5"	Poly	1.5"	1.62"	.5"	8 OZ.	PLAIN	400
150693	E-2	6"	Poly	1.5"	1.625"	.625"	13 OZ.	PLAIN	500
150204	-	8"	Poly	2"	2.25"	.75"	2 LBS.	PLAIN	600
150691	BTW	10"	Poly	2.25"	2.75"	1.00"	2.5 LBS.	PLAIN	750
Phenolic Resin Wheels**									
053902	-	5"	Phenolic	2"	2.1875"	.625"	1.75 LBS.	ROLLER	1000
053769	-	5"	Phenolic	2"	2.1875"	.75"	1.75 LBS.	ROLLER	1000
053903	-	6"	Phenolic	2"	2.1875"	.625"	2.5 LBS.	ROLLER	1200
053770	-	6"	Phenolic	2"	2.1875"	.75"	2.5 LBS.	ROLLER	1200*

* BC-8 is gray non-marking TPR rubber. BC-10 is charcoal-gray non-marking TPR rubber.

** Phenolic resin wheels are non-marking.



BLUFF® Yard Ramps

BLUFF steel yard ramps work for loading from ground to dock or ground to truck, and can be portable or stationary. Capacity options start at 16,000 lbs.



BLUFF® Portable Dock/Steel Platform

Can be used in conjunction with a yard ramp, or as a free standing feature to increase loading capabilities.



BLUFF® Steel Truck Dock Boards

Provide an easy transition between a dock and truck. Standard capacities from 15,000 to 40,000 lbs.

Model T Steel Dock Board



BLUFF® Edge Of Dock Levelers

Correct the height difference between dock and trailer bed with a BLUFF EOD, while providing an easy transition. Capacities from 20,000 to 30,000 lbs.

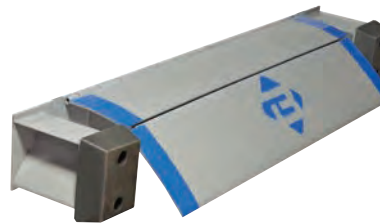

Speedy Board® Steel Dock Board



Model R Steel Rail Dock Board

Bridge the gap between a dock and railcar for safe loading and unloading of rail shipments. Capacities available from 15,000 to 90,000 lbs. Worksheet required.



BLUFF® Aluminum Dock Boards and Dock Plates

Aluminum Dock Boards

Ideal for low to medium dock loading applications, designed for use with forklifts or pallet jacks. Capacities from 10,000 to 15,000 lbs.

Aluminum Dock Plates

Lightweight plate used to transition between a truck and dock, for use with hand trucks, pallet jacks or dollies. Not forklift rated.



BLUFF® Conveyor Crossovers

Create a safe method for personnel to cross over busy conveyors. Worksheet required.



BLUFF® Wheel Risers

Eliminate unsafe below dock loading conditions with the use of wheel risers. Available in aluminum or steel. Worksheet required.

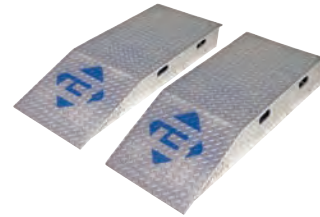

BLUFF® Mezzanine Structures

Value engineered mezzanine solutions create vertical space that can be used to create in-plant offices, observation or equipment platforms, work stations, storage areas or conveyor supports. Many add-on options available. Worksheet required.

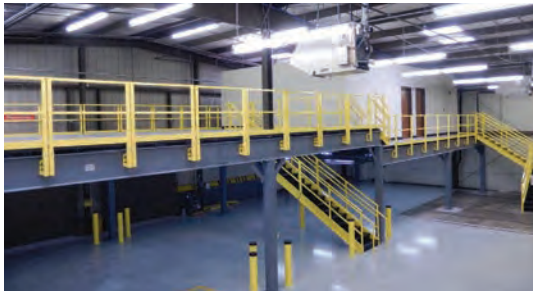

BLUFF® Safety Equipment

Protect valuable warehouse equipment and structures using Bluff's diverse offering of safety products. Powder coated safety yellow, with other standard color options available.

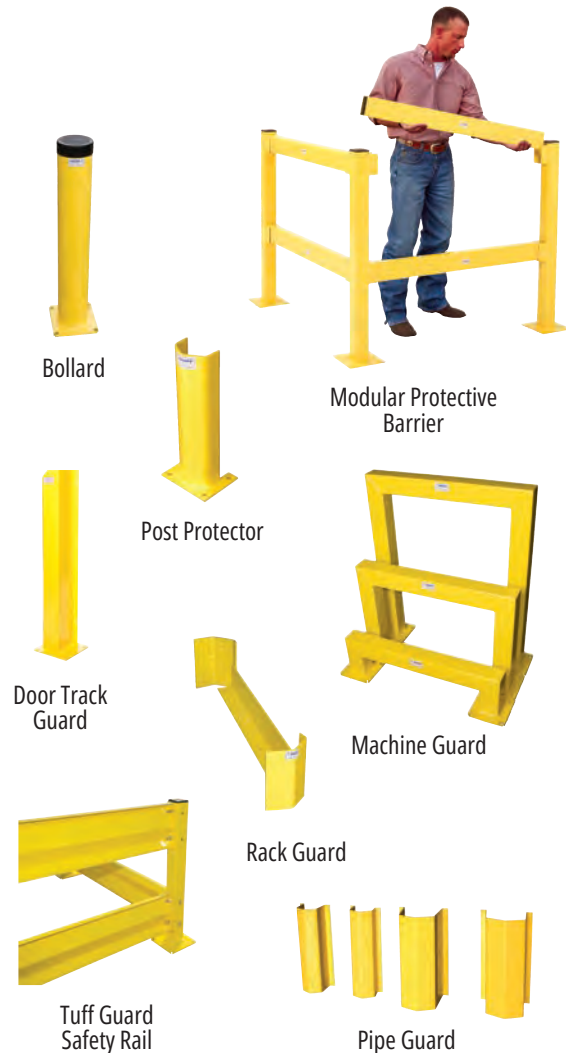

Bluff® Cantilever Rack

Maximize space both vertically and horizontally with a Bluff cantilever rack. Worksheet required. (Shown in photo with Guide Rail protection.)



NORDOCK® Dock Levelers

NORDOCK® offers a complete line of dock levelers that provide unequalled strength, reliability and ease-of-use with industry leading innovations. Pit levelers are available in Mechanical, Hydraulic, and Air-Powered activations. The exclusive smooth transfer FLEX-LIP® and the versatile TELESCOPING-LIP™ models provide unique solutions to complex loading problems. Additional products include manual and hydraulic Edge Mount, XTRA-WIDE™ and BOXCAR™ levelers. All dock levelers come in a wide range of standard sizes and capacities and can be customized for replacement or to meet customer requirements.



Vertical Storing Leveler

Rail Dock Levelers



Hydraulic Levelers

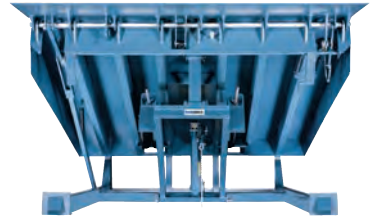

Mechanical Levelers

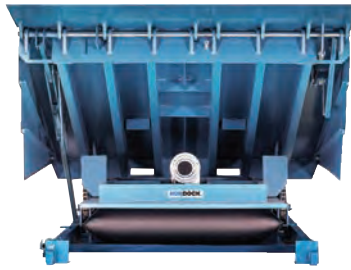

Air-Powered Levelers



Flex-Lip®



Specialty Levelers

Edge & Surface Mount Levelers

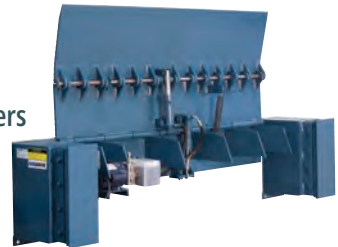

NORDOCK® TELESCOPING-LIP™ Levelers

Vertical storing dock levelers with hinged or telescoping lip and Model TLH horizontal storing dock levelers with telescoping lip are the solution for climate controlled facilities. NORDOCK® TELESCOPING-LIP™ Dock Levelers are an innovative and practical solution to common end loading issues in material handling.



Model TLH



Model NVTL



Model Tlhr Retrofit™

■ NORDOCK® Safety Products

NORDOCK® safety products include rear impact guard and wheel based vehicle restraints, run-off barrier lips, barrier gates, signal lights and LOGI-SMART® integrated control panels to control and interlock all products at the loading dock. PIT-HOOK™, TRUCK-LOCK®, POSI-CHOCK™, SHUR-LOK®, DOK-CHOCK™ and FALL-STOP™ products are all designed to increase safety by preventing premature departure and run off accidents at the loading dock. Vehicle restraints are available in manual or push button designs including the industry standard SMART-HOOK® with the least amount of moving parts that keeps working when power is lost.



Smart-Hook®



Dok-Com™



Dok-Chock™



Logi-Smart®



Truck-Lock®



Pit-Hook™



■ NORDOCK® Seals & Shelters

The WEARTOUGH® line of seals and shelters are designed to improve safety, conserve energy, and protect products from outside contaminants, while reducing costs and improving security at the loading dock. Constructed with the highest quality tear and abrasion resistant fabrics and ultra-resilient high-density foam materials, NORDOCK® seals and shelters are built to last. Comprehensive traditional compression style foam pad, foam side and rigid frame protection shelter, L-pad and inflatable curtain.



Multi-Seal™



Fc Series



Midnight™

■ NORDOCK® Lift & Specialty

NORDOCK® lift products are built to last with uncompromising standard features including high dynamic cam followers, spherical bearings, chrome pins, heavy-duty cylinders combined with more steel and a better design that simply results in a longer lasting and better performing product. Whether unloading a truck with our DOCK-LIFT™ or MAST-GUIDE™ models or lifting, turning, tilting or transferring product of any conceivable size or capacity we always strive to surpass expectations.



Dock-Lift™



Mast-Guide™



High Cycle Stacker

PRIME PICKS

When browsing the Wesco catalog, don't miss these stand-out product offerings. **Elevate your material handling operations with high quality products that increase safety.** Our carefully-curated selections are designed to improve efficiency, while keeping your employees and products safe. Gear up for a thriving future, powered by Wesco.



Ergonomic Drum Handling with Gator Grip Technology

Keep drums safe and secure with these back-saving products. ▶ [Pages 16-17](#)



COBRAPRO

The Ultimate Convertible Hand Truck: CobraPro

Safely haul heavy loads a greater distance with the help of CobraPro's power assist. ▶ [Pages 36-39](#)



Advantage Line

Delivering all of the high-value pallet trucks you need for your operation.

▶ [Pages 48-49](#)



Dock Seals

Maintain quality with our premium seals, designed to keep your products safe and the rest out: weather, pests, you name it. ▶ [Page 99](#)

1250 Welsh Rd, North Wales, PA 19454 | Phone: 215-699-7031
Fax: 215-699-3836 | www.wesco.com

WESCO[®]
Industrial Products, LLC