

# WESCO®

Industrial Products, LLC

**IWS** INTEGRATED  
WAREHOUSE  
SOLUTIONS™

## Lift Equipment



1-800-445-5681

[www.wescomfg.com](http://www.wescomfg.com)

[www.lexcoeng.com](http://www.lexcoeng.com)



**LIFT EQUIPMENT**

Steel Pedalifts: Winch & Hydraulic Lifters, Stainless Pedalifts ..... 3-4

Special Application Hydraulic & Winch Lifts..... 5

Triple Truck, Aluminum Pedalifts ..... 6

Hand Winch Lifts, Premium Light Weight Duty Winch Lift..... 7

Platform Stackers, 1,000 lb Winch Stackers ..... 8

Manual & Power Drum Rotators..... 9

Fork Stackers, 1,000 lb ..... 10

Value Office Lifts and Stackers, Options ..... 11

2,200 lb Power Drive & Counter-Balance Stackers ..... 12

1,000, 1,500, 2,000 lb Powered Stackers-Platform, Fork, Adjustable, Telescoping, Dual Platform Stacker..... 13-15

Wesco®, Lexco® Hydraulic Lift Tables, Lexco Die Handlers, Roller & Ball Transfer Tops ..... 16-22

Precision Lift Tables ..... 22

Scissors Lift Tables, Double Scissors Table, Long Deck Tables..... 23-24

Powered Lift Scissors Tables ..... 25

Pallet Levelers, Spring & Pneumatic ..... 26

Rais-N-Rol™ Machinery Movers, Furniture Movers & Trolleys..... 26-28

## Steel Frame Pedalift Features:

- 750 lb lift capacity.
- Wheel locks are standard on all models.
- Frame and lift heights vary among models.



WPL-54-2222

WPL-54-F

## Two Wheeled Winch Models

- 1-year warranty.
- Manual winch with auto-brake.
- Low maintenance design.
- Front of platform touches the ground on two wheeled model.
- Wheel lock standard.
- All 54" lifts are 60.5" O.A.H. All 40" lifts are 48.5" O.A.H.
- 8" x 2" wheels with .75" precision ball bearings.
- Adjustable forks.

### OVERALL DIMENSIONS

|    |       |       |       |       |       |
|----|-------|-------|-------|-------|-------|
| w: | 22.5" | 22.5" | 30"   | 22.5" | 22.5" |
| h: | 48.5" | 60.5" | 60.5" | 48.5" | 60.5" |
| d: | 32"   | 32"   | 32"   | 32"   | 32"   |



WDPL-54-2222

WDPL-54-F

## Four Wheeled Winch Models

- 1-year warranty.
- Manual winch with auto-brake.
- Low maintenance design.
- Platform on four wheeled model sits 5.75" above the floor.
- Wheel lock standard.
- All 54" lifts are 60.5" O.A.H. All 40" lifts are 48.5" O.A.H.
- 8"x2" wheels with .75" precision ball bearings.
- 3.5" diameter polyurethane ball bearing front swivel casters.
- Adjustable forks.

### OVERALL DIMENSIONS

|    |       |       |       |       |       |
|----|-------|-------|-------|-------|-------|
| w: | 22.5" | 22.5" | 30"   | 22.5" | 22.5" |
| h: | 48.5" | 60.5" | 60.5" | 48.5" | 60.5" |
| d: | 32"   | 32"   | 32"   | 32"   | 32"   |

| Part #                 | 260015             | 260016             | 260017             | 260018        | 260019        | 260020             | 260021             | 260022             | 260023        | 260024        |
|------------------------|--------------------|--------------------|--------------------|---------------|---------------|--------------------|--------------------|--------------------|---------------|---------------|
| Model #                | WPL-40-1620        | WPL-54-2222        | WPL-54-2230        | WPL-40-F      | WPL-54-F      | WDPL-40-1620       | WDPL-54-2222       | WDPL-54-2230       | WDPL-40-F     | WDPL-54-F     |
| Capacity               | 750 lbs            | 750 lbs            | 750 lbs            | 750 lbs       | 750 lbs       | 750 lbs            | 750 lbs            | 750 lbs            | 750 lbs       | 750 lbs       |
| Platform or Fork W x L | Platform 20" X 16" | Platform 22" x 22" | Platform 30" x 22" | Fork 3" x 18" | Fork 3" x 18" | Platform 20" x 16" | Platform 22" x 22" | Platform 30" x 22" | Fork 3" x 18" | Fork 3" x 18" |
| Lift Height            | 40"                | 54"                | 54"                | 40"           | 54"           | 40"                | 54"                | 54"                | 40"           | 54"           |
| Load Center            | 10"                | 10"                | 10"                | 10"           | 10"           | 10"                | 10"                | 10"                | 10"           | 10"           |
| Weight                 | 106 lbs            | 147 lbs            | 157 lbs            | 125 lbs       | 157 lbs       | 113 lbs            | 153 lbs            | 163 lbs            | 132 lbs       | 163 lbs       |



## Two Wheeled Hydraulic Models

- 1-year warranty.
- WESCO manufactured hydraulic Pedalift Jack, over 40 years of proven quality.
- Front tip of nose plate touches floor.
- Foot operated hydraulic pump raises platform, foot release lowers platform.
- Wheel lock standard.
- All 54" lifts are 60.5" O.A.H.  
All 40" lifts are 48.5" O.A.H.
- 8" x 2" wheels with .75" precision ball bearings.
- Adjustable forks.

### OVERALL DIMENSIONS

|    |       |       |       |       |       |
|----|-------|-------|-------|-------|-------|
| w: | 22.5" | 22.5" | 30"   | 22.5" | 22.5" |
| h: | 48.5" | 60.5" | 60.5" | 48.5" | 60.5" |
| d: | 32"   | 32"   | 32"   | 32"   | 32"   |



## Four Wheeled Hydraulic Models

- 1-year warranty.
- WESCO manufactured hydraulic Pedalift Jack, over 40 years of proven quality.
- Available 304 stainless steel construction:
  - Stainless model has 8" x 2" polyurethane tread on polypropylene hub, non-marking wheels with 440 stainless sealed 3/4" precision ball bearing
  - 304 stainless hydraulic jack.
  - 304 stainless swivel casters with plain bore 3.5" hard rubber wheels.
- Foot operated hydraulic pump raises platform, foot release lowers platform.
- Platform sits 5.75" above the floor.
- Wheel lock standard.
- All 54" lifts are 60.5" O.A.H. All 40" lifts are 48.5" O.A.H.
- 8" x 2" wheels with .75" precision ball bearings on steel models.
- 3.5" diameter polyurethane ball bearing front swivel caster on steel models.
- Adjustable forks.

### OVERALL DIMENSIONS

|    |       |       |       |       |       |       |       |
|----|-------|-------|-------|-------|-------|-------|-------|
| w: | 22.5" | 22.5" | 30"   | 22.5" | 22.5" | 22.5" | 22.5" |
| h: | 48.5" | 60.5" | 60.5" | 48.5" | 60.5" | 60.5" | 60.5" |
| d: | 32"   | 32"   | 32"   | 32"   | 32"   | 32"   | 32"   |

### 304 Stainless Steel

| Part #                 | 260001                | 260002                | 260003                | 260006           | 260007           | 260008                | 260009                | 260010                | 260011           | 260012           | 260186                | 260197           |
|------------------------|-----------------------|-----------------------|-----------------------|------------------|------------------|-----------------------|-----------------------|-----------------------|------------------|------------------|-----------------------|------------------|
| Model #                | PL-40-1620            | PL-54-2222            | PL-54-2230            | PL-40-F          | PL-54-F          | DPL-40-1620           | DPL-54-2222           | DPL-54-2230           | DPL-40-F         | DPL-54-F         | SSDPL-54-2222         | SSDPL-54-F       |
| Capacity               | 750 lbs               | 750 lbs               | 750 lbs               | 750 lbs          | 750 lbs          | 750 lbs               | 750 lbs               | 750 lbs               | 750 lbs          | 750 lbs          | 750 lbs               | 750 lbs          |
| Platform or Fork W x L | Platform<br>20" x 16" | Platform<br>22" x 22" | Platform<br>30" x 22" | Fork<br>3" x 18" | Fork<br>3" x 18" | Platform<br>20" X 16" | Platform<br>22" x 22" | Platform<br>30" x 22" | Fork<br>3" x 18" | Fork<br>3" x 18" | Platform<br>22" x 22" | Fork<br>3" x 18" |
| Lift Height            | 40"                   | 54"                   | 54"                   | 40"              | 54"              | 40"                   | 54"                   | 54"                   | 40"              | 54"              | 54"                   | 54"              |
| Load Center            | 10"                   | 10"                   | 10"                   | 10"              | 10"              | 10"                   | 10"                   | 10"                   | 10"              | 10"              | 10"                   | 10"              |
| Weight                 | 112 lbs               | 156 lbs               | 166 lbs               | 131 lbs          | 166 lbs          | 119 lbs               | 166 lbs               | 172 lbs               | 138 lbs          | 172 lbs          | 175 lbs               | 181 lbs          |



## Cylinder Truck?

See page 30 in Master Catalog.



## Hydraulic Cylinder Lift

- 1-year warranty.
- WESCO manufactured hydraulic Pedalift Jack, over 40 years of proven quality.
- Easily lifts and transports gas cylinders.
- Swivel casters make maneuvering in tight places easier.
- Two models:
  - Foot operated hydraulic pump.
  - Manual winch with auto-brake.
- Maximum cylinder diameter 9.5".
- Casters with wheel locks.

### OVERALL DIMENSIONS

|           |        |
|-----------|--------|
| w: 20"    | 20"    |
| h: 54"    | 58"    |
| d: 29.25" | 29.25" |



## Universal Lift

- 1-year warranty.
- Two straps with buckles to help secure load, 9' wrap around and 5' front to back.
- Manual winch with auto brake.
- Two 8" wheels and two 3 1/2" polyurethane casters.
- Lowered platform sits 6" above ground.
- Ideal for placing rental equipment on to pickup truck or into van.

### OVERALL DIMENSIONS

|           |
|-----------|
| w: 29.25" |
| h: 61"    |
| d: 46.4"  |

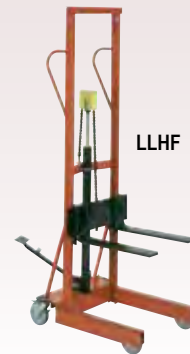

## Hydraulic Lite-Lift

- 1-year warranty.
- WESCO manufactured hydraulic Pedalift Jack, over 40 years of proven quality.
- Foot operated hydraulic pump.
- Release foot pedal for controlled lowering.
- Casters with wheel locks.
- Adjustable forks.

### OVERALL DIMENSIONS

|          |       |
|----------|-------|
| w: 20"   | 20"   |
| h: 70.5" | 70.5" |
| d: 30"   | 30"   |



## Platform Option

- Provides the utility of two units.
- Easy installation - no tools required.
- Part # - 260157
- Model # - POK



To order option, add Part # or Model # to Lite-Lift Part # or Model #.



## Winch Lite-Lift

- 1-year warranty.
- Manual winch with auto-brake.
- No catches to release.
- Low maintenance.
- Casters with wheel locks.

### OVERALL DIMENSIONS

|          |       |
|----------|-------|
| w: 20"   | 20"   |
| h: 70.5" | 70.5" |
| d: 30"   | 30"   |

| Part #                 | 260161             | 260163             | 260130             | 260150             | 260151               | 260152             | 260153               |
|------------------------|--------------------|--------------------|--------------------|--------------------|----------------------|--------------------|----------------------|
| Model #                | LLHPB              | LLWPB              | ULP2630            | LLHP               | LLHF                 | LLWP               | LLWF                 |
| Capacity               | 300 lbs            | 300 lbs            | 750 lbs            | 500 lbs            | 500 lbs              | 500 lbs            | 500 lbs              |
| Platform or Fork W x L | Platform 12" x 20" | Platform 12" x 20" | Platform 26" x 30" | Platform 20" x 20" | Fork 3" x 19" x .75" | Platform 20" x 20" | Fork 3" x 19" x .75" |
| Lift Height            | 40" / Hydraulic    | 40" / Winch        | 54"                | 54"                | 54"                  | 54"                | 54"                  |
| Lowered Height         | 1/4"               | 1/4"               | 6"                 | 5.75"              | 4.25"                | 5.75"              | 4.25"                |
| Caster / Wheel Size    | 5"                 | 5"                 | 3.5" / 8"          | 5"                 | 5"                   | 5"                 | 5"                   |
| Front Leg Span         | N/A                | N/A                | N/A 19.75" OD      | 15.25" ID x 20" OD | 15.25" ID 20" OD     | 15.25" ID 20" OD   | 15.25" ID 20" OD     |
| Load Center            | 10"                | 10"                | 6"                 | 10"                | 10"                  | 10"                | 10"                  |
| Weight                 | 165 lbs            | 152 lbs            | 224 lbs            | 139 lbs            | 157 lbs              | 103 lbs            | 124 lb               |

# WESCO® TRIPLE TRUCK / ALUMINUM PEDALIFTS



261160 Frame w/  
261161 Drum Lifter



261160 Frame w/  
261162 Adjustable Forks



261160 Frame w/  
261163 Platform

A WESCO EXCLUSIVE  
**5 YEAR GUARANTEE**  
★ AGAINST WELD FAILURE ★

## Aluminum Frame Pedalifts features:

- Aluminum construction for lightweight ruggedness.
- 20" deep x 22" wide platform size.
- Wheel locks are standard on all models.
- Front of platform touches the floor.
- Frame and lift heights vary among models.



WMPL-54-2022  
Winch/Platform



MPL-54-2022  
Hydraulic/Platform

## Triple Truck

- 1-YEAR WARRANTY, PATENT NO. US9,139,214B2.

- Handles most standard rim 30, 55 and 85 gal. steel, poly and fiber drums.
- Manual winch with auto brake.
- 3 Models of Lifting Attachments - **No tools required:**

- #261161 - Gator Grip® Drum Lifter Attachment

- #261162 - Adjustable Width Forks -6" to 19 1/2" O.D.

- #261163 - Platform - 21 1/4" W x 28 1/2" D. (Optional slip-on over forks.) Requires adjustable fork option.

- Carriage lock, lock carriage in place at any position.
- Easy load rollers assist loading onto a truck bed.

### HOW TO ORDER:

Frame and attachments ordered separately.

1. Purchase basic frame - Part #261160.
2. Select lifting attachment.
  - a. Gator Grip® Drum Lifter - Part #261161.
  - b. Adjustable Forks - Part #261162.
  - c. Slip-on Platform\* - Part #261163. (Requires adjustable fork option.)

- Low-profile 3" debris deflecting neoprene swivel casters.
- Floor to top of leg height - 3.75".
- 10" x 2.75" poly hub solid rubber wheels - Part # 150698.
- Wheel lock - pedal activated.
- Lever operated outrigger adjustment - 3 positions.
- Outrigger angle can be changed even under full load.

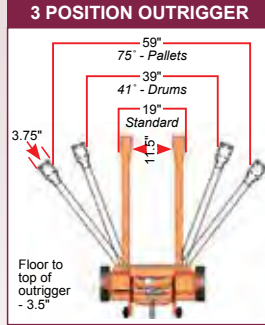

**LOOK**

### OVERALL DIMENSIONS

|           |     |
|-----------|-----|
| w: 30"    | 16" |
| h: 70.75" | 33" |
| d: 52.25" | 12" |

## Two Wheeled Winch Models

- 1-year warranty.
- Manual winch with auto-brake.
- Light weight minimizes the effort required for moving and lifting.
- Wheel lock standard.
- 8"x2" wheels with .75" ball bearings.

### OVERALL DIMENSIONS

|          |          |
|----------|----------|
| w: 22.5" | w: 22.5" |
| h: 48.5" | h: 60.5" |
| d: 32"   | d: 32"   |

## Two Wheeled Hydraulic Models

- 1-year warranty.
- Foot operated hydraulic pump raises platform, foot release lowers platform.
- WESCO manufactured hydraulic Pedalift Jack, over 40 years of proven quality.
- Wheel lock standard.
- 8"x2" wheels with .75" ball bearings.

### OVERALL DIMENSIONS

|          |          |
|----------|----------|
| w: 22.5" | w: 22.5" |
| h: 48.5" | h: 60.5" |
| d: 32"   | d: 32"   |



| Part #                 | 261160          | 261161     | 261162                 | 261163                     | 260025             | 260026             | 260004             | 260005             |
|------------------------|-----------------|------------|------------------------|----------------------------|--------------------|--------------------|--------------------|--------------------|
| Model #                | TTF             | TTF-GG     | TTF-AF                 | TTF-P                      | WMPL-40-2022       | WMPL-54-2022       | MPL-40-2022        | MPL-54-2022        |
| Capacity               | 750 lbs         | 750 lbs    | 750 lbs                | 750 lbs                    | 400 lbs            | 400 lbs            | 400 lbs            | 400 lbs            |
| Platform or Fork W x L | FRAME ONLY      | GATOR GRIP | ADJ. FORKS 3" x 26.75" | PLATFORM* 21.25" x 28.125" | Platform 22" x 20" | Platform 22" x 20" | Platform 22" x 20" | Platform 22" x 20" |
| Front Leg Span         | SEE CHART ABOVE |            |                        |                            | N/A                | N/A                | N/A                | N/A                |
| Lowered Height         | N/A             | 28.75"     | 4"                     | 5"                         | N/A                | N/A                | N/A                | N/A                |
| Lift Height            | N/A             | 69"        | 62"                    | 62.125"                    | 40"                | 54"                | 40"                | 54"                |
| Caster / Wheel Size    | 3" / 10"        | N/A        | N/A                    | N/A                        | 8" x 2"            | 8" x 2"            | 8" x 2"            | 8" x 2"            |
| Load Center            | N/A             | 16"        | 16"                    | 16"                        | 10"                | 10"                | 10"                | 10"                |
| Weight                 | 224 lbs         | 32 lbs     | 30 lbs                 | 6 lbs                      | 61 lbs             | 68 lbs             | 71 lbs             | 77 lbs             |

\*Requires Adjustable Fork Option

SINCE 1948





**273510**  
Fixed Base  
(Forks Down)



**273510**  
Fixed Base  
(Forks Up)



**273516**  
Counter-balance Straddle  
(Forks Down)



**273513**  
Adjustable Straddle  
(Forks Down)

## Optional Removable Steel Platform

- Fits over forks.
- Size: 20.5"W x 24.25"L.
- Weight: 26 lbs.
- Part #273518

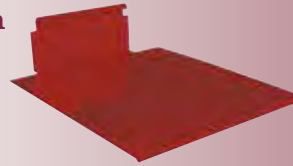

With optional support backrest and foldable platform.

## Hand Winch Lifters

- Capacities: 350, 400 and 500 lbs.
- Aluminum and steel construction.
- 8" rear wheels and 2" front swivel casters are non-marking.
- Forks can be inverted for two different lift heights. Fork size: 4"W x 22.5"L x 1.75"H.
- Winch crank handle locks to secure carriage.
- Three models:
  - **Fixed Base** used in narrow work spaces. Base legs: 13" inside width x 21.5" overall width.
  - **Adjustable Straddle** with adjustable legs 21.5" to 36" inside width and 29" to 44" outside width.
  - **Counter-balance Straddle.** Short legs get you close to load when there is no room for standard legs. 5" polyurethane rear swivel casters with brakes and 4" front wheels.
- Top of frame rollers facilitates laying truck horizontal for transport.

### OVERALL DIMENSIONS

|    |     |     |     |     |     |     |     |     |
|----|-----|-----|-----|-----|-----|-----|-----|-----|
| w: | 24" | 24" | 29" | 29" | 29" | 29" | 29" | 29" |
| h: | 68" | 68" | 79" | 68" | 68" | 68" | 68" | 68" |
| d: | 35" | 35" | 43" | 43" | 43" | 47" | 47" | 47" |

## Premium Light Duty Winch Lift

- 1 Year Warranty on parts only.
- Zinc-plated finish.
- Suitable for clean environments.
- Swivel caster; 3/4" polyurethane dual wheel.
- Easy maneuvering in tight or narrow spaces.
- 2" lifting strap.
- Manual winch with auto brake.
- Optional zinc-plated cargo support backrest. Part #274531.
- Optional 304 stainless steel foldable platform.- 15.125" x 23.25" - Part #274530.

### OVERALL DIMENSIONS

|    |         |
|----|---------|
| w: | 23.25"  |
| h: | 54.125" |
| d: | 29.25"  |

| Part #                | 273510     | 273511       | 273512              | 273513              | 273514              | 273515                   | 273516                   | 273517                   | 274520                           |
|-----------------------|------------|--------------|---------------------|---------------------|---------------------|--------------------------|--------------------------|--------------------------|----------------------------------|
| Model #               | HWLFX-4    | HWLFX-5      | HWLSD-3.5           | HWLSD-4             | HWLSD-5             | HWLCB-3.5                | HWLCB-4                  | HWLCB-5                  | DWL-43                           |
| Capacity              | 400 lbs    | 500 lbs      | 350 lbs             | 400 lbs             | 500 lbs             | 350 lbs                  | 400 lbs                  | 500 lbs                  | 265 lbs                          |
| Base                  | Fixed      | Fixed        | Adjustable Straddle | Adjustable Straddle | Adjustable Straddle | Counter-balance Straddle | Counter-balance Straddle | Counter-balance Straddle | Fork Dimension 1.375" Dia. x 15" |
| Max. Lift Range*      | 98" / 120" | 47" / 70"    | 120" / 142"         | 98" / 120"          | 47" / 70"           | 120" / 142"              | 98" / 120"               | 47" / 70"                | 43"                              |
| Lowered Height Range* | 3.5" / 25" | 3.5" / 27.5" | 1.25" / 21.5"       | 1.25" / 21.5"       | 1.25" / 21.5"       | 1.25" / 21.5"            | 2" / 25"                 | 2" / 25"                 | 3.25"                            |
| Load Center           | 11.25"     | 11.25"       | 11.25"              | 11.25"              | 11.25"              | 11.25"                   | 11.25"                   | 11.25"                   | 15.25"                           |
| Weight                | 154 lbs    | 143 lbs      | 176 lbs             | 165 lbs             | 154 lbs             | 405 lbs                  | 394 lbs                  | 383 lbs                  | 55 lbs                           |

\* Forks down / forks up dimensions.



# 1,000 LB. HYDRAULIC & WINCH PLATFORM STACKERS

## Hydraulic Stackers features:

- Floor locks, safety screen and foot guard are standard on all models.
- Forks touch the floor on all fork models.
- Front phenolic wheels are 5" diameter.
- Rear phenolic swivel casters are 4" diameter.
- Hydraulic jack manufactured by WESCO.
- "S" standard line features one piece platform guide rail.
- "E" economy line offers an economical price value.
- Foot pedal - pump and release.



SPL-60-2424



A WESCO EXCLUSIVE  
**5 YEAR GUARANTEE**  
★ AGAINST WELD FAILURE ★

## Wesco Large Platform Models

- 1-year warranty.
- WESCO manufactured hydraulic Stacker Jack, over 40 years of proven quality.
- 30" deep x 32" wide heavy gauge platform with 5.25" lowered height.
- 18" load center.
- Base leg span - 25.5" inside, 32" outside.
- NEW Low Profile Outrigger Option available. See below.



SPL-80-3032



ESPL-60-3032

## Wesco Platform Models

- 1-year warranty.
- WESCO manufactured hydraulic Stacker Jack, over 40 years of proven quality.
- 24" x 24" heavy gauge platform with 5.75" lowered height.
- 15" load center.
- Base leg span - 15" inside, 21" outside.
- NEW Low Profile Outrigger Option available.



ESPL-60-2424

|                     | OVERALL DIMENSIONS |              |             |              |             |              | OVERALL DIMENSIONS |              |             |              |             |              |
|---------------------|--------------------|--------------|-------------|--------------|-------------|--------------|--------------------|--------------|-------------|--------------|-------------|--------------|
|                     | Standard           | Economy      | Standard    | Economy      | Standard    | Economy      | Standard           | Economy      | Standard    | Economy      | Standard    | Economy      |
| w:                  | 25.5"              | 25.5"        | 25.5"       | 25.5"        | 25.5"       | 25.5"        | 32"                | 32"          | 32"         | 32"          | 32"         | 32"          |
| h:                  | 75"                | 72"          | 83"         | 80"          | 94"         | 92"          | 75"                | 83"          | 72"         | 83"          | 94"         | 92"          |
| d:                  | 40"                | 40"          | 38"         | 40"          | 40"         | 40"          | 44.5"              | 44.5"        | 44.5"       | 44.5"        | 44.5"       | 44.5"        |
| Part #              | 260032             | 260044       | 260033      | 260045       | 260034      | 260046       | 260038             | 260050       | 260039      | 260051       | 260040      | 260052       |
| Model #             | SPL-60-2424        | ESPL-60-2424 | SPL-68-2424 | ESPL-68-2424 | SPL-80-2424 | ESPL-80-2424 | SPL-60-3032        | ESPL-60-3032 | SPL-68-3032 | ESPL-68-3032 | SPL-80-3032 | ESPL-80-3032 |
| Capacity            | 1,000 lbs          | 1,000 lbs    | 1,000 lbs   | 1,000 lbs    | 1,000 lbs   | 1,000 lbs    | 1,000 lbs          | 1,000 lbs    | 1,000 lbs   | 1,000 lbs    | 1,000 lbs   | 1,000 lbs    |
| Platform/Fork W x L | 24" x 24"          | 24" x 24"    | 24" x 24"   | 24" x 24"    | 24" x 24"   | 24" x 24"    | 32" x 30"          | 32" x 30"    | 32" x 30"   | 32" x 30"    | 32" x 30"   | 32" x 30"    |
| Lift Height         | 60"                | 60"          | 68"         | 68"          | 80"         | 80"          | 60"                | 60"          | 68"         | 68"          | 80"         | 80"          |
| Load Center         | 15"                | 15"          | 15"         | 15"          | 15"         | 15"          | 18"                | 18"          | 18"         | 18"          | 18"         | 18"          |
| Weight              | 233 lbs            | 226 lbs      | 248 lbs     | 234 lbs      | 274 lbs     | 263 lbs      | 272 lbs            | 265 lbs      | 295 lbs     | 273 lbs      | 317 lbs     | 298 lbs      |
| Low Profile Option  | Yes                | Yes          | Yes         | Yes          | Yes         | Yes          | Yes                | Yes          | Yes         | Yes          | Yes         | Yes          |

## 1,000 lb Capacity Winch Stacker



- 1-year warranty.
- Heavy duty 1,000 lb capacity.
- Heavy duty winch with auto brake.
- Floor lock and safety screen are standard.
- Swivel casters - 4" x 2" phenolic.
- Load wheels - 5" x 2" phenolic.
- Lowered height - 5.25".
- NEW Low Profile Outrigger Option available.



SWPL-68-2424

### OVERALL DIMENSIONS

w: 24"  
h: 83.25"  
d: 41"

|                     |              |
|---------------------|--------------|
| Part #              | 270214       |
| Model #             | SWPL-68-2424 |
| Capacity            | 1,000 lbs    |
| Platform/Fork W x L | 24" x 24"    |
| Lift Height         | 70"          |
| Load Center         | 15"          |
| Weight              | 238 lbs      |
| Low Profile Option  | Yes          |

## Low Profile Outrigger Option

- Available only on fixed base, platform, fork, hydraulic or winch 1,000 lb. capacity stackers.
- Standard stacker outrigger height - 5 1/2".
- Optional low profile height - 2 1/2".
- To order add "LP" to stacker Part #.  
Example: 260032-LP.

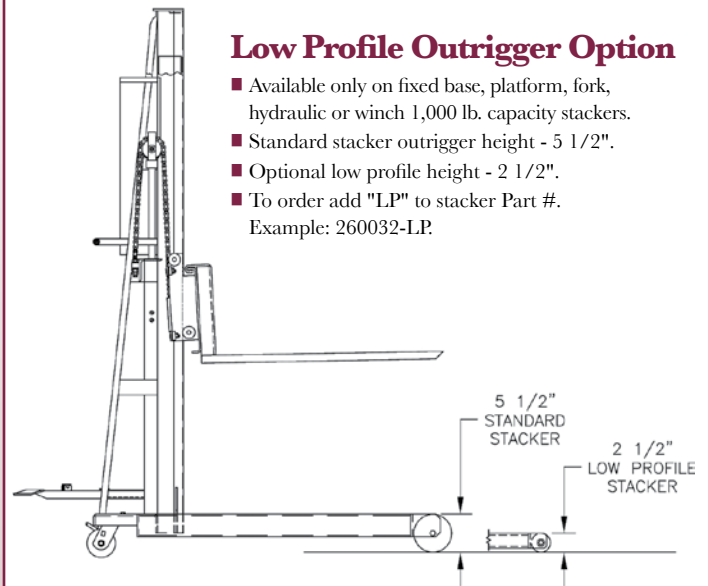

SINCE 1948



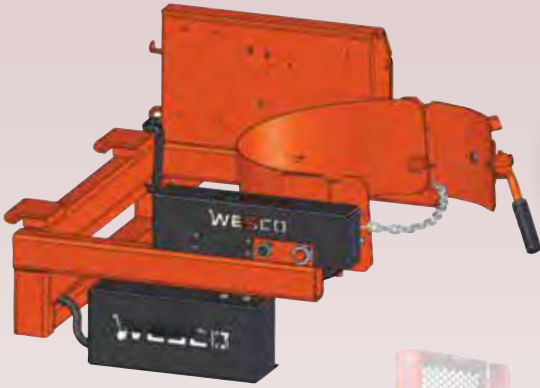

**Power Drum Rotator**  
Part #240145

**STACKER NOT INCLUDED**



**Manual Drum Rotator**  
Part #240144

**STACKER NOT INCLUDED**



## Wesco Power Drum Rotator

- Fully self-contained
- No stacker modifications required
- Wireless remote control for safe operation
- Heavy duty battery for extended operation
- On-board charger
- Industrial gear motor drive
- Handles 55 gallon, 30 gallon and fiber drums (w/attachments)
- Ships assembled and boxed
- Capacity: 800 lbs./full drum 500 lbs./half drum
- For use with Wesco Counterbalance Stackers and Fork Model Stackers (with 25" or greater ID outrigger span)

### OVERALL DIMENSIONS

w: 35"  
h: 20.75"  
d: 30.5"

## Wesco Manual Drum Rotator

- Manual geared tilting configuration that allows for full drum rotational control using a traditional chain (144" length) and wheel design.
- Geared design allows controlled dumping and dispensing
- 30:1 gear ratio
- Removable tilt handle
- For use with Wesco Counterbalance Stackers and Fork Model Stackers (with 25" or greater ID outrigger span)

### OVERALL DIMENSIONS

w: 35"  
h: 15"  
d: 30.5"

|          |                                     |                                     |
|----------|-------------------------------------|-------------------------------------|
| Part #   | 240145                              | 240144                              |
| Model #  | PDRA-55-1K                          | DRA-55-1K                           |
| Capacity | 800 lb/full drum - 500 lb/half drum | 800 lb/full drum - 500 lb/half drum |
| Weight   | 150 lbs                             | 118 lbs                             |

## OPTIONS



**DMG-30A - 30 Gallon Insert**  
Part# 270040



**FBA - Fiber Drum Adapter**  
Part# 270402



# 1,000 LB. FORK STACKERS

A WESCO EXCLUSIVE  
**5 YEAR GUARANTEE**  
 \* AGAINST WELD FAILURE \*

## Wesco Fork Model

- 1-year warranty.
- 1" thick x 3" wide x 25" long forks.
- Adjustable fork range:  
 minimum - 6.125" O.D.  
 maximum - 25" O.D.
- 15" load center.
- 25.5" overall width; 40" depth.
- Base leg span - 15" inside, 21" outside.
- Forks lower to ground.
- WESCO manufactured hydraulic Stacker Jack, over 40 years of proven quality.
- NEW Low Profile Outrigger Option available. (See page 8.)



SFL-56-25



SFL-76-25

### OVERALL DIMENSIONS

|    |       |       |       |       |       |       |
|----|-------|-------|-------|-------|-------|-------|
| w: | 25.5" | 25.5" | 25.5" | 25.5" | 25.5" | 25.5" |
| h: | 75"   | 72"   | 83"   | 80"   | 94"   | 92"   |
| d: | 44.5" | 44"   | 44.5" | 44"   | 44.5" | 44"   |

|                     | Standard  | Economy    | Standard  | Economy    | Standard  | Economy    |
|---------------------|-----------|------------|-----------|------------|-----------|------------|
| Part #              | 260035    | 260047     | 260036    | 260048     | 260037    | 260049     |
| Model #             | SFL-56-25 | ESFL-56-25 | SFL-64-25 | ESFL-64-25 | SFL-76-25 | ESFL-76-25 |
| Capacity            | 1,000 lbs | 1,000 lbs  | 1,000 lbs | 1,000 lbs  | 1,000 lbs | 1,000 lbs  |
| Platform/Fork W x L | 3" x 25"  | 3" x 25"   | 3" x 25"  | 3" x 25"   | 3" x 25"  | 3" x 25"   |
| Lift Height         | 56"       | 56"        | 64"       | 64"        | 76"       | 76"        |
| Load Center         | 15"       | 15"        | 15"       | 15"        | 15"       | 15"        |
| Weight              | 265 lbs   | 258 lbs    | 273 lbs   | 266 lbs    | 306 lbs   | 295 lbs    |
| Low Profile Option  | Yes       | Yes        | Yes       | Yes        | Yes       | Yes        |



## Straddle Fork Model

- 1-year warranty.
- 1" thick x 3" wide x 30" long forks.
- Adjustable fork range:  
 minimum - 6.125" O.D.  
 maximum - 25" O.D.
- 18" load center.
- 32" overall width; 44" depth.
- Base leg span - 25.5" inside, 32" outside.
- Forks lower to ground.
- WESCO manufactured hydraulic Stacker Jack, over 40 years of proven quality.
- NEW Low Profile Outrigger Option available. (See page 8.)

SFL-64-30S



## Wide Straddle Fork Model

- 1-year warranty.
- 1" thick x 3" wide x 30" long forks.
- Base leg span - 42" inside, 48.75" outside.
- Adjustable fork range:  
 minimum - 6.125" O.D.  
 maximum - 25" O.D.
- Overall width 48.75", depth 48.25".
- Forks lower to the ground.
- NOT AVAILABLE - Low profile option.
- WESCO manufactured hydraulic Stacker Jack, over 40 years of proven quality.



ESFL-56-30-42S

### OVERALL DIMENSIONS

|    |       |       |       |       |       |       |       |
|----|-------|-------|-------|-------|-------|-------|-------|
| w: | 32.5" | 32.5" | 32.5" | 32.5" | 32.5" | 32.5" | 48.5" |
| h: | 75"   | 72"   | 83"   | 80"   | 94"   | 92"   | 72.5" |
| d: | 48"   | 48"   | 48"   | 48"   | 48"   | 48"   | 49"   |

|                    | Standard   | Economy     | Standard   | Economy     | Standard   | Economy     | Wide           |
|--------------------|------------|-------------|------------|-------------|------------|-------------|----------------|
| Part #             | 260041     | 260053      | 260042     | 260054      | 260043     | 260055      | 260075         |
| Model #            | SFL-56-30S | ESFL-56-30S | SFL-64-30S | ESFL-64-30S | SFL-76-30S | ESFL-76-30S | ESFL-56-30-42S |
| Capacity           | 1,000 lbs  | 1,000 lbs   | 1,000 lbs  | 1,000 lbs   | 1,000 lbs  | 1,000 lbs   | 1,000 lbs      |
| Fork W x L         | 3" x 30"   | 3" x 30"    | 3" x 30"   | 3" x 30"    | 3" x 30"   | 3" x 30"    | 3" x 30"       |
| Lift Height        | 56"        | 56"         | 64"        | 64"         | 76"        | 76"         | 56"            |
| Load Center        | 18"        | 18"         | 18"        | 18"         | 18"        | 18"         | 18"            |
| Weight             | 288 lbs    | 281 lbs     | 298 lbs    | 289 lbs     | 333 lbs    | 322 lbs     | 352 lbs        |
| Low Profile Option | Yes        | Yes         | Yes        | Yes         | Yes        | Yes         | No             |



SINCE 1948

Adjustable Fork Model  
272940

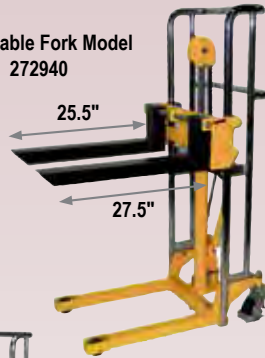

With optional platform  
#272942

Chrome plated platform is an option.

## Value Lift

- Adjustable 4" wide x 25.5" long forks.
- Optional, removable chrome plated 22" wide x 26" long platform.
- Foot operated hydraulic pump.
- Two 5" polyurethane swivel casters with brake and two 3" polyurethane rigid wheels.
- Two lift heights: 47" and 59".
- Chrome plated rails and handle.
- Ships KD.
- #272942 Optional Platform fits both Manual and Electric Value Lift Stackers.

### OVERALL DIMENSIONS

|          |       |     |
|----------|-------|-----|
| w: 22.5" | 22.5" | 22" |
| h: 55"   | 70"   | 1"  |
| d: 36"   | 37"   | 26" |



Control Panel



VLP-59

## Electric Value Lift Stackers

- Adjustable 4" wide x 25.5" long forks.
- Optional, removable 22" wide x 26" long platform.
- Two 5" polyurethane swivel casters with brake and two 3" polyurethane rigid wheels.
- Two lift heights: 47" and 59".
- Chrome plated rails and handles.
- UL approved charger.
- Sealed maintenance-free battery.
- Keyed on/off switch.
- Raise/lower controls.
- #272942 Optional Platform fits both Manual and Electric Value Lift Stackers.

### OVERALL DIMENSIONS

|          |       |
|----------|-------|
| w: 22.5" | 22.5" |
| h: 55"   | 68"   |
| d: 44"   | 44"   |



MOL



EOL

## Manual and Electric Office Lifts

- Ideal for narrow aisles.
- Great for offices.
- Two models, manual and electric.
- Lightweight, but sturdy.
- Sealed battery and automatic charger built in.
- Remote up and down pendant for electric model.
- 9/16" thick plastic platform.

### OVERALL DIMENSIONS

|          |       |
|----------|-------|
| w: 23.5" | 23.5" |
| h: 71.5" | 78"   |
| d: 32"   | 34"   |

## Options for Office Lifts



Single Spindle Model EP05-01  
Part #274654  
Double Spindle Model EP06-01  
Part #274655

- Roll raw material picking



Bin Clamp Model EP08-01  
Part #274657

- Plastic bin picking



Roller Platform Model EP02-01  
Part #274651

- Stainless steel rollers make transport smooth, easy clean up

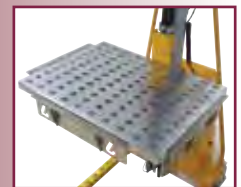

Stainless Ball Transfer Model EP01-01  
Part #274650

- Smoothly operating from 3 directions on/off the platform



V Block Model EP03-01  
Part #274652

- V block shape specially for roll material transport

|                        | Value Lift              |                         |                    | VLP                     |                         | Office Lifts              |                           |
|------------------------|-------------------------|-------------------------|--------------------|-------------------------|-------------------------|---------------------------|---------------------------|
|                        | Value Lift              | Value Lift              | Optional Platform  | Manual                  | Electric                | Manual                    | Electric                  |
| Part #                 | 272940                  | 272941                  | 272942             | 273203                  | 273204                  | 272467                    | 272468                    |
| Model #                | VL47                    | VL59                    | VLRP               | VLP-47                  | VLP-59                  | MOL                       | EOL                       |
| Capacity               | 880 lbs                 | 880 lbs                 | N/A                | 880 lbs                 | 880 lbs                 | 220 lbs                   | 220 lbs                   |
| Platform or Fork W x L | Fork 4" x 25.5"         | Fork 4" x 25.5"         | Platform 22" x 26" | Fork 4" x 25.5"         | Fork 4" x 25.5"         | Platform 18" x 23"        | Platform 18" x 23"        |
| Lift Height            | 3.5" - 47"              | 3.5" - 59"              | N/A                | 3.5" - 47"              | 3.5" - 59"              | 58.5"                     | 66"                       |
| Lowered Height         | 3.5"                    | 3.5"                    | N/A                | 3.5"                    | 3.5"                    | 5"                        | 5"                        |
| Adj. Fork Width        | 8.5" - 19.5"            | 8.5" - 19.5"            | N/A                | 8.25" - 21.5"           | 8.25" - 21.5"           | N/A                       | N/A                       |
| Swivel Casters         | 5" Locking Polyurethane | 5" Locking Polyurethane | N/A                | 5" Locking Polyurethane | 5" Locking Polyurethane | 5" x 1.25" Hard Rubber    | 5" x 1.25" Hard Rubber    |
| Load Wheels            | 3" Rigid Polyurethane   | 3" Rigid Polyurethane   | N/A                | 3" Rigid Polyurethane   | 3" Rigid Polyurethane   | 2.75" x 1.25" Hard Rubber | 2.75" x 1.25" Hard Rubber |
| Battery                | N/A                     | N/A                     | N/A                | 12V 80AH                | 12V 80AH                | N/A                       | 12V                       |
| Load Center            | 12.75"                  | 12.75"                  | N/A                | 12.75"                  | 12.75"                  | 9.25"                     | 9.25"                     |
| Weight                 | 178 lbs                 | 187 lbs                 | 10 lbs             | 269 lbs                 | 280 lbs                 | 104 lbs                   | 146 lbs                   |



## POWER AND MANUAL DRUM ROTATOR ATTACHMENTS

Page 9



Power Drum Rotator  
Part #240145



Manual Drum Rotator  
Part #240144



### 2,200 lb Capacity Power Drive Stacker

- **6 Month Warranty on parts only.**
- **Can not be used with pallets - only skids without bottom slates.**
- Lift height of 98 3/4". Dual chain lift.
- Includes two, 12 volt, 187 AH, sealed batteries and a separate UL approved charger.
- Power propulsion system takes the effort out of moving heavy loads. Also provides easy steering.
- Fingertip control provides variable forward and reverse speeds.
- Automatic safety stop on top of control post. Unit shuts down when safety stop comes into contact with an obstacle.
- Load wheels, steering wheel and drive wheel are all molton polyurethane.
- Adjustable forks.

#### OVERALL DIMENSIONS

w: 35"  
h: 70" - 117.5"  
d: 64"

### Features of Counter-Balance Powered Line of Stackers

- **Meets ANSI B56.10 specifications.**
- **Maximum lift capacity - 1,000 lbs.**
- **Remote control, floor lock, and safety screen are standard on all models.**
- **With a minimally charged battery, unit can be used while recharging**
- **Easy to read illuminated battery status voltmeter - no extra cost!**



Standard features include:

- remote control
- voltmeter
- on/off switch.



### Counter-Balance Powered Stacker

- **1-year warranty.**
- **Proven quality: WESCO manufactured Hydraulic Cylinder.**
- Battery and charger included.
- Applications include:
  - Loading and unloading trucks.
  - Positioning dies.
  - Feeding material to presses.
- 25" long forks standard.
- 30" long fork models available, 850 lb. max. capacity.
- Order enough weight kits for your planned load. (See chart below.)
- **AC models not available.**



261039

**Note: Counter-Balance Stackers require appropriate counter-weights. See chart below.**

#### OVERALL DIMENSIONS

|          |       |       |
|----------|-------|-------|
| w: 26.5" | 26.5" | 26.5" |
| h: 75"   | 83"   | 94"   |
| d: 59.5" | 59.5" | 59.5" |

|                     |                        |
|---------------------|------------------------|
| Part #              | 272943                 |
| Model               | EKS-10                 |
| Capacity            | 2,200 lbs              |
| Lowered Mast Height | 70"                    |
| Raised Mast Height  | 117.5"                 |
| Leg ID/OD           | 19" / 27"              |
| Fork Size<br>W x L  | 5" x 35.25"            |
| Outside Fork Spread | 12" - 29" - Adjustable |
| Lowered Fork Height | 2.6"                   |
| Raised Fork Height  | 98.25"                 |
| Load Center         | 17.5"                  |
| Weight              | 826 lbs                |

|                         |                       |                       |                       |
|-------------------------|-----------------------|-----------------------|-----------------------|
| Part #                  | 261037                | 261038                | 261039                |
| Model #                 | PCBFL-56-25           | PCBFL-64-25           | PCBFL-76-25           |
| Capacity                | 1,000 lbs             | 1,000 lbs             | 1,000 lbs             |
| Fork W x L              | 3" x 25"              | 3" x 25"              | 3" x 25"              |
| Outside Fork Spread     | 6" - 25" - Adjustable | 6" - 25" - Adjustable | 6" - 25" - Adjustable |
| Lift Height             | 56"                   | 64"                   | 76"                   |
| Wheel:<br>Front<br>Rear | 5"<br>5"              | 5"<br>5"              | 5"<br>5"              |
| Load Center             | 13"                   | 13"                   | 13"                   |
| Weight*                 | 560 lbs               | 574 lbs               | 611 lbs               |

\*Weight of stacker without counterweights.

### Counter-Balance Weights

|                       |         |         |           |
|-----------------------|---------|---------|-----------|
| Part #                | 261041  | 261042  | 261043    |
| Counterweight         | 200 lbs | 400 lbs | 600 lbs   |
| Stacker Load Capacity | 334 lbs | 668 lbs | 1,000 lbs |



# WESCO® 1,000 LB. POWER LIFT STACKERS



261024



## Platform Model

- 1-year warranty.
- Proven quality: WESCO manufactured Hydraulic Cylinder.
- Battery and charger included.
- Lowered height 5.75"
- Phenolic wheels on front and phenolic casters on rear.
- Power Drive Option available: see page 13 for details. Add "-PD" to end of Part #.
- 110V AC models available (Special Order). Add AC to end of Part #.
- NEW Low Profile Outrigger Option available.

### OVERALL DIMENSIONS

|          |       |       |
|----------|-------|-------|
| w: 25.5" | 25.5" | 25.5" |
| h: 72"   | 80"   | 92"   |
| d: 36"   | 36"   | 36"   |

### 24" x 24" Platform Models

| Part #                 | 261022             | 261023             | 261024             | 261028             | 261029             | 261030             |
|------------------------|--------------------|--------------------|--------------------|--------------------|--------------------|--------------------|
| Model #                | PESPL-60-2424      | PESPL-68-2424      | PESPL-80-2424      | PESFL-56-25        | PESFL-64-25        | PESFL-76-25        |
| Capacity               | 1,000 lbs          | 1,000 lbs          | 1,000 lbs          | 1,000 lbs          | 1,000 lbs          | 1,000 lbs          |
| Platform or Fork W x L | Platform 24" x 24" | Platform 24" x 24" | Platform 24" x 24" | Fork 3" x 25"      | Fork 3" x 25"      | Fork 3" x 25"      |
| Lift Height            | 60"                | 68"                | 80"                | 56"                | 64"                | 76"                |
| Leg ID/OD              | 15"/21"            | 15"/21"            | 15"/21"            | 15"/21"            | 15"/21"            | 15"/21"            |
| Wheel:                 |                    |                    |                    |                    |                    |                    |
| Front                  | 5" phenolic        | 5" phenolic        | 5" phenolic        | 5" phenolic        | 5" phenolic        | 5" phenolic        |
| Rear                   | 4" phenolic swivel | 4" phenolic swivel | 4" phenolic swivel | 4" phenolic swivel | 4" phenolic swivel | 4" phenolic swivel |
| Load Center            | 15"                | 15"                | 15"                | 15"                | 15"                | 15"                |
| Weight                 | 418 lbs            | 428 lbs            | 457 lbs            | 452 lbs            | 460 lbs            | 489 lbs            |
| Low Profile Option     | Yes                | Yes                | Yes                | Yes                | Yes                | Yes                |

### 30" x 32" Platform Models

| Part #                 | 261025             | 261026             | 261027             | 261031        | 261032        | 261033        |
|------------------------|--------------------|--------------------|--------------------|---------------|---------------|---------------|
| Model #                | PESPL-60-3032      | PESPL-68-3032      | PESPL-80-3032      | PESFL-56-30S  | PESFL-64-30S  | PESFL-76-30S  |
| Capacity               | 1,000 lbs          | 1,000 lbs          | 1,000 lbs          | 1,000 lbs     | 1,000 lbs     | 1,000 lbs     |
| Platform or Fork W x L | Platform 32" x 30" | Platform 32" x 30" | Platform 32" x 30" | Fork 3" x 30" | Fork 3" x 30" | Fork 3" x 30" |
| Lift Height            | 60"                | 68"                | 80"                | 56"           | 64"           | 76"           |
| Leg ID/OD              | 25.5" / 32"        | 25.5" / 32"        | 25.5" / 32"        | 25.5"/32"     | 25.5"/32"     | 25.5"/32"     |
| Wheel:                 |                    |                    |                    |               |               |               |
| Front                  | 5" rigid           | 5" rigid           | 5" rigid           | 5" phenolic   | 5" phenolic   | 5" phenolic   |
| Rear                   | 4" swivel          | 4" swivel          | 4" swivel          | 4" swivel     | 4" swivel     | 4" swivel     |
| Load Center            | 18"                | 18"                | 18"                | 18"           | 18"           | 18"           |
| Weight                 | 404 lbs            | 427 lbs            | 452 lbs            | 442 lbs       | 456 lbs       | 465 lbs       |
| Low Profile Option     | Yes                | Yes                | Yes                | No            | No            | No            |



261033



## Fork Model

- 1-year warranty.
- Proven quality: WESCO manufactured Hydraulic Cylinder.
- Battery and charger included.
- Forks lower to floor on all models.
- 5" phenolic wheels on front, 4" swivel on rear.
- Power Drive Option available: see page 13 for details. Add "-PD" to end of Part #.
- 110V AC models available (Special Order). Add AC to end of Part #.
- Adjustable fork range: minimum - 6" O.D. maximum - 25" O.D.
- NEW Low Profile Outrigger Option available.

### OVERALL DIMENSIONS

|          |       |       |
|----------|-------|-------|
| w: 25.5" | 25.5" | 25.5" |
| h: 72"   | 80"   | 92"   |
| d: 44.5" | 44.5" | 44.5" |

### Fork Models



261035



## Adjustable Span Straddle Model

- 1-year warranty.
- Proven quality: WESCO manufactured Hydraulic Cylinder.
- Battery and charger included.
- Forks lower to floor on all models.
- Extra deep (40") straddle legs and forks for lifting pallets.
- Versatile adjustable span straddle legs can be set from 34" to 50" inside dimension to handle most standard pallets.
- Power Drive Option available: see page 13 for details.
- 110V AC models available (Special Order). Add AC to end of Part #.
- Adjustable fork range: minimum - 6" O.D., maximum - 25" O.D.
- Low Profile Option not available.

### OVERALL DIMENSIONS

|            |         |         |
|------------|---------|---------|
| w: 54" Max | 54" Max | 54" Max |
| h: 72"     | 80"     | 92"     |
| d: 58.75"  | 58.75"  | 58.75"  |

### Adjustable Straddle Fork Models

| Part #                 | 261034             | 261035             | 261036             |
|------------------------|--------------------|--------------------|--------------------|
| Model #                | PASFL-56-40S       | PASFL-64-40S       | PASFL-76-40S       |
| Capacity               | 1,000 lbs          | 1,000 lbs          | 1,000 lbs          |
| Platform or Fork W x L | Fork 3" x 40"      | Fork 3" x 40"      | Fork 3" x 40"      |
| Lift Height            | 56"                | 64"                | 76"                |
| Leg ID/OD              | 34" to 50" ID Adj. | 34" to 50" ID Adj. | 34" to 50" ID Adj. |
| Wheel:                 |                    |                    |                    |
| Front                  | 5" phenolic        | 5" phenolic        | 5" phenolic        |
| Rear                   | 4" phenolic swivel | 4" phenolic swivel | 4" phenolic swivel |
| Load Center            | 20"                | 20"                | 20"                |
| Weight                 | 510 lbs            | 518 lbs            | 554 lbs            |
| Low Profile Option     | No                 | No                 | No                 |

## Low Profile Outrigger Option

- Available only on fixed base, platform, fork, hydraulic or winch, 1,000 lb. capacity stackers.
- Standard stacker outrigger height - 5 1/2".
- Optional low profile height - 2 1/2".
- To order add "LP" to stacker Part #. Example: 260032-LP.

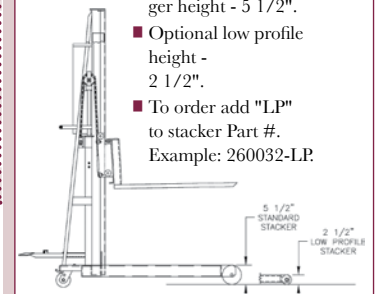



# 1,500-2,000 LB. POWER LIFT FORK STACKERS



A WESCO EXCLUSIVE  
**5 YEAR GUARANTEE**  
 ★ AGAINST WELD FAILURE ★

## 1,500 & 2,000 lb Capacity Powered Stackers - Fork Models

- 1-year warranty.
- Proven quality: WESCO manufactured Hydraulic Cylinder.
- Meets ANSI B56.10 specifications.
- Battery and charger included.
- Adjustable forks:
  - Lower to floor on all models.
  - 3" wide x 25", 30" and 42" long.
  - OD adjustment from 6" to 24.5" or 29" maximum width.
- Adjustable base legs available on fork models.
- Reinforced frame and base.
- Double chain, lift support.
- Heavy-duty pump.
- Ergonomic "D" handles.
- 5th wheel option see page below.
- Power Drive Option available: see page 13 for details. Add "-PD" to end of Part #.



261053

## 30 Fixed and 6 Adjustable Base Leg Fork Models

| Part # | Model #                | Lift Height | Overall Height | Weight lbs | Capacity lbs | Load Center | Fork Width/Length | Base Leg ID/OD  | Adj. Fork Min./Max. OD |
|--------|------------------------|-------------|----------------|------------|--------------|-------------|-------------------|-----------------|------------------------|
| 261079 | PSFL-56-25-15S-1.5K    | 56"         | 72"            | 512        | 1,500        | 15"         | 3"/25"            | 15"/21"         | 6" / 24.5"             |
| 261080 | PSFL-64-25-15S-1.5K    | 64"         | 83"            | 532        | 1,500        | 15"         | 3"/25"            | 15"/21"         | 6" / 24.5"             |
| 261081 | PSFL-76-25-15S-1.5K    | 76"         | 94"            | 596        | 1,500        | 15"         | 3"/25"            | 15"/21"         | 6" / 24.5"             |
| 261082 | PSFL-86-25-15S-1.5K    | 86"         | 104"           | 642        | 1,500        | 15"         | 3"/25"            | 15"/21"         | 6" / 24.5"             |
| 261083 | PSFL-56-25-20S-1.5K    | 56"         | 72"            | 523        | 1,500        | 15"         | 3"/25"            | 20"/26"         | 6" / 24.5"             |
| 261084 | PSFL-64-25-20S-1.5K    | 64"         | 83"            | 543        | 1,500        | 15"         | 3"/25"            | 20"/26"         | 6" / 24.5"             |
| 261085 | PSFL-76-25-20S-1.5K    | 76"         | 94"            | 607        | 1,500        | 15"         | 3"/25"            | 20"/26"         | 6" / 24.5"             |
| 261086 | PSFL-86-25-20S-1.5K    | 86"         | 104"           | 654        | 1,500        | 15"         | 3"/25"            | 20"/26"         | 6" / 24.5"             |
| 261092 | PSFL-56-25-20S-2K      | 56"         | 72"            | 523        | 2,000        | 15"         | 3"/25"            | 20"/26"         | 6" / 24.5"             |
| 261093 | PSFL-64-25-20S-2K      | 64"         | 83"            | 558        | 2,000        | 15"         | 3"/25"            | 20"/26"         | 6" / 24.5"             |
| 261094 | PSFL-76-25-20S-2K      | 76"         | 94"            | 611        | 2,000        | 15"         | 3"/25"            | 20"/26"         | 6" / 24.5"             |
| 261095 | PSFL-86-25-20S-2K      | 86"         | 104"           | 659        | 2,000        | 15"         | 3"/25"            | 20"/26"         | 6" / 24.5"             |
| 261059 | PSFL-64-30-30S-1.5K    | 64"         | 83"            | 566        | 1,500        | 18"         | 3"/30"            | 30"/36"         | 6" / 29"               |
| 261060 | PSFL-76-30-30S-1.5K    | 76"         | 94"            | 630        | 1,500        | 18"         | 3"/30"            | 30"/36"         | 6" / 29"               |
| 261061 | PSFL-86-30-30S-1.5K    | 86"         | 104"           | 677        | 1,500        | 18"         | 3"/30"            | 30"/36"         | 6" / 29"               |
| 261044 | PSFL-64-30-30S-2K      | 64"         | 83"            | 571        | 2,000        | 18"         | 3"/30"            | 30"/36"         | 6" / 29"               |
| 261045 | PSFL-76-30-30S-2K      | 76"         | 94"            | 635        | 2,000        | 18"         | 3"/30"            | 30"/36"         | 6" / 29"               |
| 261046 | PSFL-86-30-30S-2K      | 86"         | 104"           | 682        | 2,000        | 18"         | 3"/30"            | 30"/36"         | 6" / 29"               |
| 261062 | PSFL-64-42-42S-1.5K    | 64"         | 83"            | 571        | 1,500        | 24"         | 3"/42"            | 42"/48"         | 6" / 29"               |
| 261063 | PSFL-76-42-42S-1.5K    | 76"         | 94"            | 637        | 1,500        | 24"         | 3"/42"            | 42"/48"         | 6" / 29"               |
| 261064 | PSFL-86-42-42S-1.5K    | 86"         | 104"           | 688        | 1,500        | 24"         | 3"/42"            | 42"/48"         | 6" / 29"               |
| 261047 | PSFL-64-42-42S-2K      | 64"         | 83"            | 577        | 2,000        | 24"         | 3"/42"            | 42"/48"         | 6" / 29"               |
| 261048 | PSFL-76-42-42S-2K      | 76"         | 94"            | 642        | 2,000        | 24"         | 3"/42"            | 42"/48"         | 6" / 29"               |
| 261049 | PSFL-86-42-42S-2K      | 86"         | 104"           | 693        | 2,000        | 24"         | 3"/42"            | 42"/48"         | 6" / 29"               |
| 261065 | PSFL-64-42-50S-1.5K    | 64"         | 83"            | 577        | 1,500        | 24"         | 3"/42"            | 50"/56"         | 6" / 29"               |
| 261066 | PSFL-76-42-50S-1.5K    | 76"         | 94"            | 642        | 1,500        | 24"         | 3"/42"            | 50"/56"         | 6" / 29"               |
| 261067 | PSFL-86-42-50S-1.5K    | 86"         | 104"           | 693        | 1,500        | 24"         | 3"/42"            | 50"/56"         | 6" / 29"               |
| 261050 | PSFL-64-42-50S-2K      | 64"         | 83"            | 582        | 2,000        | 24"         | 3"/42"            | 50"/56"         | 6" / 29"               |
| 261051 | PSFL-76-42-50S-2K      | 76"         | 94"            | 647        | 2,000        | 24"         | 3"/42"            | 50"/56"         | 6" / 29"               |
| 261052 | PSFL-86-42-50S-2K      | 86"         | 104"           | 698        | 2,000        | 24"         | 3"/42"            | 50"/56"         | 6" / 29"               |
| 261068 | PASFL-64-42-3550S-1.5K | 64"         | 83"            | 587        | 1,500        | 24"         | 3"/42"            | 35"-50" ID ADJ. | 6" / 29"               |
| 261069 | PASFL-76-42-3550S-1.5K | 76"         | 94"            | 652        | 1,500        | 24"         | 3"/42"            | 35"-50" ID ADJ. | 6" / 29"               |
| 261070 | PASFL-86-42-3550S-1.5K | 86"         | 104"           | 703        | 1,500        | 24"         | 3"/42"            | 35"-50" ID ADJ. | 6" / 29"               |
| 261053 | PASFL-64-42-3550S-2K   | 64"         | 83"            | 592        | 2,000        | 24"         | 3"/42"            | 35"-50" ID ADJ. | 6" / 29"               |
| 261054 | PASFL-76-42-3550S-2K   | 76"         | 94"            | 657        | 2,000        | 24"         | 3"/42"            | 35"-50" ID ADJ. | 6" / 29"               |
| 261055 | PASFL-86-42-3550S-2K   | 86"         | 104"           | 708        | 2,000        | 24"         | 3"/42"            | 35"-50" ID ADJ. | 6" / 29"               |

### 5th Wheel Steering Option



5th Wheel Steering Option for easier mobility and precision steering in confined areas. Available only on 1,500 and 2,000 lb models. 8" locking polyurethane wheels. Spring loaded handle. Turning radius: 73.5". Can be field installed. Order as separate option under Part # 261099.

### Adjustable Width Legs 6 Models



SINCE 1948



# POWERED STACKERS - SINGLE & DUAL PLATFORMS

## 1,500 & 2,000 lb Capacity Powered Stackers - Platform Models

- 1-year warranty.
- Proven quality: WESCO manufactured Hydraulic Cylinder.
- Meets ANSI B56.10 specifications.
- Battery and charger included.
- Platform models lowered height 6".
- Adjustable base legs available on fork models only.
- Fixed platforms 24" x 24", 24" x 27", 30" x 32".
- Reinforced frame and base.
- Double chain, lift support.
- **Dual platform stacker #262056, call for details.**
- Heavy-duty pump.
- Ergonomic "D" handles.
- 5th wheel option see page 70.
- **Power Drive Option** available: see below for details. Add "-PD" to end of Part #.

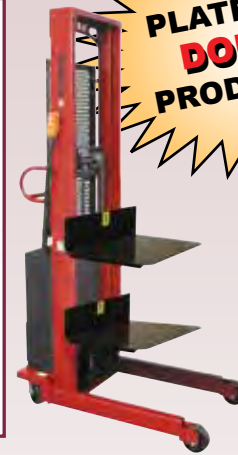
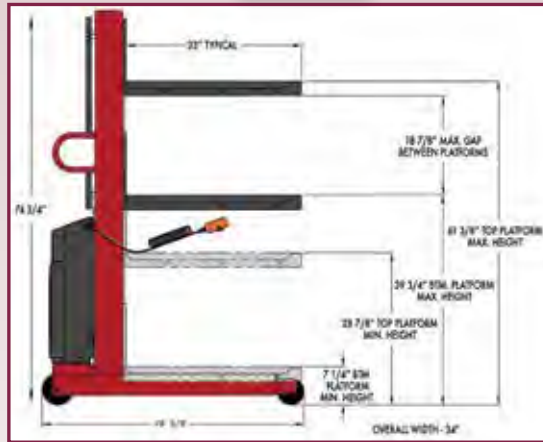

**TWO PLATFORMS!  
DOUBLE PRODUCTION**



#261074

### Fixed Base Leg Platform Models

| Part # | Model #               | Lift Height | Overall Height | Weight lbs | Capacity lbs | Load Center | Platform Width/Length | Base Leg ID/OD |
|--------|-----------------------|-------------|----------------|------------|--------------|-------------|-----------------------|----------------|
| 261074 | PSPL-60-2424-15S-1.5K | 60"         | 72"            | 468        | 1,500        | 15"         | 24" x 24"             | 15"/21"        |
| 261075 | PSPL-68-2424-15S-1.5K | 68"         | 83"            | 482        | 1,500        | 15"         | 24" x 24"             | 15"/21"        |
| 261076 | PSPL-80-2424-15S-1.5K | 80"         | 94"            | 523        | 1,500        | 15"         | 24" x 24"             | 15"/21"        |
| 261077 | PSPL-90-2424-15S-1.5K | 90"         | 104"           | 563        | 1,500        | 15"         | 24" x 24"             | 15"/21"        |
| 261088 | PSPL-60-2427-20S-2K   | 60"         | 72"            | 476        | 2,000        | 15"         | 27" x 24"             | 20"/26"        |
| 261089 | PSPL-68-2427-20S-2K   | 68"         | 83"            | 487        | 2,000        | 15"         | 27" x 24"             | 20"/26"        |
| 261090 | PSPL-80-2427-20S-2K   | 80"         | 94"            | 530        | 2,000        | 15"         | 27" x 24"             | 20"/26"        |
| 261091 | PSPL-90-2427-20S-2K   | 90"         | 104"           | 569        | 2,000        | 15"         | 27" x 24"             | 20"/26"        |
| 261071 | PSPL-60-3032-30S-1.5K | 60"         | 72"            | 479        | 1,500        | 18"         | 32" x 30"             | 30"/36"        |
| 261072 | PSPL-68-3032-30S-1.5K | 68"         | 83"            | 492        | 1,500        | 18"         | 32" x 30"             | 30"/36"        |
| 261073 | PSPL-80-3032-30S-1.5K | 80"         | 94"            | 534        | 1,500        | 18"         | 32" x 30"             | 30"/36"        |
| 261078 | PSPL-90-3032-30S-1.5K | 90"         | 104"           | 573        | 1,500        | 18"         | 32" x 30"             | 30"/36"        |
| 261056 | PSPL-60-3032-30S-2K   | 60"         | 72"            | 484        | 2,000        | 18"         | 32" x 30"             | 30"/36"        |
| 261057 | PSPL-68-3032-30S-2K   | 68"         | 83"            | 497        | 2,000        | 18"         | 32" x 30"             | 30"/36"        |
| 261058 | PSPL-80-3032-30S-2K   | 80"         | 94"            | 539        | 2,000        | 18"         | 32" x 30"             | 30"/36"        |
| 261087 | PSPL-90-3032-30S-2K   | 90"         | 104"           | 578        | 2,000        | 18"         | 32" x 30"             | 30"/36"        |
| 262056 | PDPL-61-3033-30S-2K   | 61.375"     | 74.75"         | 674        | 2,000        | 18.25"      | 33" x 30"             | 30"/36"        |



Model # PSFL-86-25-20S-2K-PD  
2,000 lb. capacity and 86" lift height



Easy fingertip controls.



High torque motor drive.



Model # PESPL-80-2424-PD  
1,000 lb. capacity platform model with 80" lift height



### Optional Power Drive System for Fork and Platform Stackers

- Variable speed, steerable power drive system allows a single user to easily control forward and reverse movement of stacker.
- Simple to use finger-tip controls are built into steering handle.
- 180° hinged design allows precision steering in confined spaces.
- Spring-loaded mechanism automatically compensates for uneven floors ensuring drive wheels maintain constant contact with floor.
- Two maintenance-free sealed batteries provide plenty of power for propulsion and lift.
- 1,000 - 2,000 lb. capacities.
- Automatic emergency safety switch instantly reverses direction if control post comes in contact with obstacle.



Model # PCBFL-64-25-PD  
1,000 lb. capacity counter-balance model

**Battery Powered System provides both propulsion and lift!**  
*Eliminates the stress and strain of lifting and transporting heavy loads. All Wesco power lift stackers can be ordered as power drive models (except for telescoping models). All other operating specifications are the same as equivalent power lift-only models. To order, simply add "-PD" to the end of the Model #.*

EQUIPMENT



# WESCO® LIFT TABLES / OPTIONS



LT-02-1616



LT-10-1836

## Features:

- Capacity ranges from 200 to 6,000 lbs.
- Solid steel top and base construction.
- Casters provide easy mobility.
- Floor locks are standard on all 500 lb.+ capacity tables.



LT-60-2436

## Wesco Standard Duty Tables (200 - 1,000 lb Capacities)

- 1-year warranty.
- LT-02-1616 has four 3" hard rubber swivel casters.
- LT-02-1616 ships via UPS knocked down.
- LT-05 and LT-10 models feature 2 rigid and 2 swivel 4" phenolic resin roller bearing wheel casters.
- 7 Gauge steel top and base.
- 3/8" lift per stroke.

|    | OVERALL DIMENSIONS |       |        |        |
|----|--------------------|-------|--------|--------|
| w: | 16"                | 18"   | 18"    | 18"    |
| h: | 28.5"              | 30.5" | 30.5"  | 30.5"  |
| d: | 16"                | 16"   | 21.25" | 39.25" |

## Wesco Medium & Heavy Duty Tables (2,000-6,000 lb Capacities)

- 1-year warranty.
- LT models feature 2 rigid and 2 swivel 6" phenolic resin roller bearing wheel casters.
- Four support posts and push handle.
- Foot operated floor lock.
- LTL models feature 2 rigid and 2 swivel 4" phenolic resin roller bearing wheel casters.
- Wesco made hydraulic pump with 3/8" lift per stroke.

|    | OVERALL DIMENSIONS |        |        |        |        |        |        |        |
|----|--------------------|--------|--------|--------|--------|--------|--------|--------|
| w: | 24"                | 32"    | 24"    | 32"    | 24"    | 32"    | 24"    | 32"    |
| h: | 30.5"              | 30.5"  | 37"    | 37"    | 37"    | 37"    | 37"    | 37"    |
| d: | 39.25"             | 51.25" | 39.25" | 51.25" | 39.25" | 51.25" | 39.25" | 51.25" |

| Part #           | 260059     | 260060     | 260061     | 260062      | 260063      | 260064     | 260065     | 260066     | 260067     | 260068     | 260069     |
|------------------|------------|------------|------------|-------------|-------------|------------|------------|------------|------------|------------|------------|
| Model #          | LT-02-1616 | LT-05-1818 | LT-10-1836 | LTL-20-2436 | LTL-20-3248 | LT-20-2436 | LT-20-3248 | LT-40-2436 | LT-40-3248 | LT-60-2436 | LT-60-3248 |
| Capacity         | 200 lbs    | 500 lbs    | 1,000 lbs  | 2,000 lbs   | 2,000 lbs   | 2,000 lbs  | 2,000 lbs  | 4,000 lbs  | 4,000 lbs  | 6,000 lbs  | 6,000 lbs  |
| Table Size W x L | 16" x 16"  | 18" x 18"  | 18" x 36"  | 24" x 36"   | 32" x 48"   | 24" x 36"  | 32" x 48"  | 24" x 36"  | 32" x 48"  | 24" x 36"  | 32" x 48"  |
| Lowered Height   | 28.5"      | 30.5"      | 30.5"      | 30.5"       | 30.5"       | 37"        | 37"        | 37"        | 37"        | 37"        | 37"        |
| Raised Height    | 46"        | 47.5"      | 47.5"      | 47.5"       | 47.5"       | 59"        | 59"        | 59"        | 59"        | 59"        | 59"        |
| Caster Size      | 3"         | 4"         | 4"         | 4"          | 4"          | 6"         | 6"         | 6"         | 6"         | 6"         | 6"         |
| Support Posts    | None       | 2          | 2          | 4           | 4           | 4          | 4          | 4          | 4          | 4          | 4          |
| Weight           | 54 lbs     | 122 lbs    | 168 lbs    | 308 lbs     | 350 lbs     | 339 lbs    | 465 lbs    | 349 lbs    | 475 lbs    | 359 lbs    | 485 lbs    |

## Value Lift Tables

- Polyurethane casters.
- Foot operated pump and release.
- Ships KD.
- 36 pumps to fully raised height.

|    | OVERALL DIMENSIONS |     |
|----|--------------------|-----|
| w: | 16"                | 18" |
| h: | 29"                | 30" |
| d: | 16"                | 18" |



272469



272470

| Part #          | 272469        | 272470                  |
|-----------------|---------------|-------------------------|
| Model #         | VLT200        | VLT500                  |
| Capacity        | 200 lbs       | 500 lbs                 |
| Table Size      | 16" x 16"     | 18" x 18"               |
| Lowered Height  | 29"           | 30"                     |
| Raised Height   | 46"           | 48"                     |
| Support Posts   | None          | Two                     |
| Floor Lock (FL) | N/A           | Yes                     |
| Caster Size     | (4) swivel 3" | (2) rigid (2) swivel 4" |
| Weight          | 76 lbs        | 153 lbs                 |

## 5 Table-Top Options

- Factory installed only.
- Call for price.
- Not available on 16" or 18" wide tables.
- For both manual and powered Wesco-made tables only.
- Table capacity determines option capacity.
- Roller: diameter 1.9" with 7/16" hex axle.
- 1 3/8" diameter ball transfer.
- Push-Pull and Roller Top options have two directions of travel: length or width.
- To order:
  - select table Part No. (manual or powered).
  - select Option and add as suffix to table Part No.
  - Example: 260062-PPL
- 24" x 36", 2,000 lb. capacity, manual table with a Push-Pull option that travels the length of the table.



## PPL (Push-Pull)

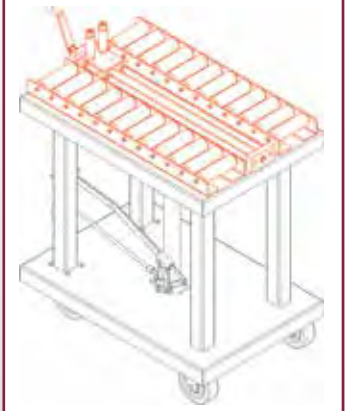

**Travel: Length of table**  
**Suffix Code: PPL**  
**Table top to top of roller: 3"**



SINCE 1948



# WESCO POWERED LIFT TABLES / OPTIONS

Remote control for raising/lowering. Magnets on back of remote allow for storage anywhere on table.



261102



## Available with Power Drive

- Combines power lift and power drive capabilities.
- Power drive option weighs 160 lbs.
- To order Power Drive, add -PD to the end of Model #.

### Example:

Lift Table                      Power Drive  
**#PLT-10-1836              #PLT-10-1836-PD**



Shown With Power Drive Option - 261105-PD

## Powered Lift Tables

- 1-year warranty.
- Up to 6,000 lbs capacity.
- High volume output pump raises 1.5" per second without load.
- Standard floor lock holds table steady for loading and unloading.
- Easy to read illuminated battery status voltmeter.
- With a minimally charged battery, unit can be used while recharging.

**Push-pull, roller and ball tops available on Wesco 24" x 36" and 32" x 48" manual and power tables.**

### OVERALL DIMENSIONS

|           |        |        |        |        |        |        |        |        |
|-----------|--------|--------|--------|--------|--------|--------|--------|--------|
| w: 18"    | 24"    | 32"    | 24"    | 32"    | 24"    | 32"    | 24"    | 32"    |
| h: 30.5"  | 30.5"  | 30.5"  | 37"    | 37"    | 37"    | 37"    | 37"    | 37"    |
| d: 39.25" | 39.25" | 51.25" | 39.25" | 51.25" | 39.25" | 51.25" | 39.25" | 51.25" |

| Part #          | 261108      | 261100       | 261101       | 261102      | 261103      | 261104      | 261105      | 261106      | 261107      |
|-----------------|-------------|--------------|--------------|-------------|-------------|-------------|-------------|-------------|-------------|
| Model #         | PLT-10-1836 | PLTL-20-2436 | PLTL-20-3248 | PLT-20-2436 | PLT-20-3248 | PLT-40-2436 | PLT-40-3248 | PLT-60-2436 | PLT-60-3248 |
| Capacity        | 1,000 lbs   | 2,000 lbs    | 2,000 lbs    | 2,000 lbs   | 2,000 lbs   | 4,000 lbs   | 4,000 lbs   | 6,000 lbs   | 6,000 lbs   |
| Table Top W x L | 18" x 36"   | 24" x 36"    | 32" x 48"    | 24" x 36"   | 32" x 48"   | 24" x 36"   | 32" x 48"   | 24" x 36"   | 32" x 48"   |
| Raised Ht       | 47.5"       | 47.5"        | 47.5"        | 59"         | 59"         | 59"         | 59"         | 59"         | 59"         |
| Lowered Ht      | 30.5"       | 30.5"        | 30.5"        | 37"         | 37"         | 37"         | 37"         | 37"         | 37"         |
| Caster Size     | 4"          | 4"           | 4"           | 6"          | 6"          | 6"          | 6"          | 6"          | 6"          |
| Weight          | 415 lbs     | 472 lbs      | 597 lbs      | 567 lbs     | 607 lbs     | 597 lbs     | 607 lbs     | 597 lbs     | 607 lbs     |



### PPW (Push-Pull)

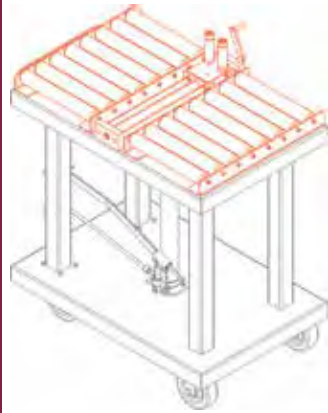

Travel: Width of table  
 Suffix Code: PPW  
 Table top to top of roller: 3"



### RTL (Roller-Top)

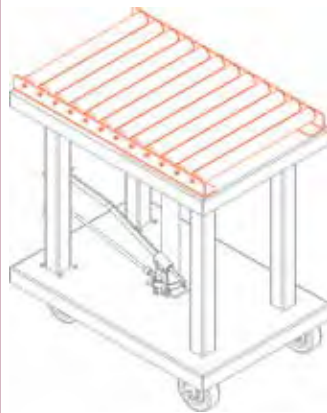

Travel: Length of table  
 Suffix Code: RTL  
 Table top to top of roller: 3"



### RTW (Roller-Top)

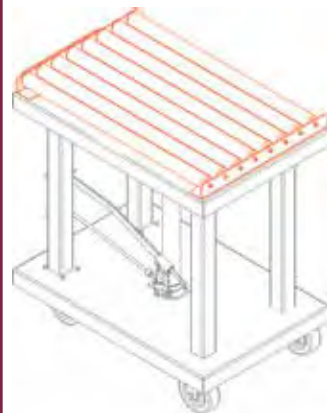

Travel: Width of table  
 Suffix Code: RTW  
 Table top to top of roller: 3"



### BT (Ball Transfer)

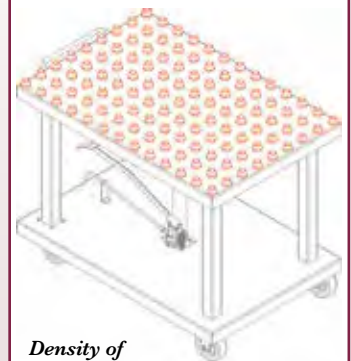

Density of balls determined by table top size and capacity.

1" diameter balls  
 Suffix Code: BT  
 Table top to top of ball: 1 3/8"

LIFT EQUIPMENT



HT-200-FR

Also see Wesco Lift Tables on page 16.



LT-02-1616



LT-05-1818

## 200 lb. Capacity Foot Operated Hydraulic Lift Table

- 1-year warranty.
- Top and base 1/4" steel.
- Top rotates 360°.
- 4 swivel 2" diameter rubber casters.

## 300 lb. Capacity Foot Operated Hydraulic Lift Table

- 1-year warranty.
- Top and base 3/8" steel.
- 2 rigid and 2 swivel 3 1/2" diameter rubber casters.
- Optional phenolic resin and polyurethane caster wheels.
- Floor lock.
- Two posts.

| Part #         | 492220    | 492221    | 492222    | 492223    | 492224    | 492225    | 492226    | 492227    | 492228    |
|----------------|-----------|-----------|-----------|-----------|-----------|-----------|-----------|-----------|-----------|
| Model #        | HT-200-FR | HT-203-FR | HT-201-FR | HT-209-FR | HT-300-FR | HT-318-FR | HT-316-FR | HT-314-FR | HT-312-FR |
| Capacity       | 200 lbs   | 200 lbs   | 200 lbs   | 200 lbs   | 300 lbs   | 300 lbs   | 300 lbs   | 300 lbs   | 300 lb    |
| Table Size     | 16" x 16" | 16" x 16" | 16" x 16" | 16" x 16" | 18" x 18" | 18" x 18" | 18" x 18" | 18" x 18" | 18" x 18" |
| Lowered Height | 26"       | 24"       | 22"       | 20"       | 30"       | 28"       | 26"       | 24"       | 22"       |
| Raised Height  | 44"       | 40"       | 36"       | 32"       | 48"       | 46"       | 42"       | 38"       | 34"       |
| Caster Size    | 2"        | 2"        | 2"        | 2"        | 3.5"      | 3.5"      | 3.5"      | 3.5"      | 3.5"      |
| Lift           | 18"       | 16"       | 14"       | 12"       | 18"       | 18"       | 16"       | 14"       | 12"       |
| Weight         | 53 lbs    | 52 lbs    | 51 lbs    | 50 lbs    | 135 lbs   | 131 lbs   | 128 lbs   | 124 lbs   | 121 lbs   |



## 400 lb. & 500 lb. Capacity Foot Operated Hydraulic Lift Table

- 1-year warranty.
- Top and base 12 gauge steel.
- 2 rigid and 2 swivel 5" diameter rubber casters.
- Floor lock.
- Optional phenolic resin, polyurethane and steel caster wheels.
- Precision telescoping guide tubes.



HT-500-FR

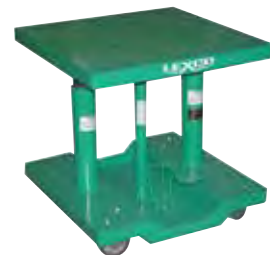

HT-2388-05-FR with Drop-Base

| Part #           | 492229    | 492230    | 492231    | 492232    | 496037    | 492234        | 492235        | 492236        | 492237        | 492238        |
|------------------|-----------|-----------|-----------|-----------|-----------|---------------|---------------|---------------|---------------|---------------|
| Model #          | HT-400-FR | HT-416-FR | HT-414-FR | HT-412-FR | HT-500-FR | HT-2388-05-FR | HT-2368-05-FR | HT-2346-05-FR | HT-2324-05-FR | HT-2302-05-FR |
| Capacity         | 400 lbs   | 400 lbs   | 400 lbs   | 400 lbs   | 500 lbs   | 500 lbs       | 500 lbs       | 500 lbs       | 500 lbs       | 500 lbs       |
| Table Size W x L | 18" x 24" | 18" x 24" | 18" x 24" | 18" x 24" | 20" x 30" | 20" x 30"     | 20" x 30"     | 20" x 30"     | 20" x 30"     | 20" x 30"     |
| Lowered Height   | 30"       | 28"       | 26"       | 24"       | 30"       | 28"           | 26"           | 24"           | 22"           | 20"           |
| Raised Height    | 48"       | 44"       | 40"       | 36"       | 48"       | 46"           | 44"           | 40"           | 36"           | 32"           |
| Caster Size      | 5"        | 5"        | 5"        | 5"        | 5"        | 5"            | 5"            | 5"            | 5"            | 5"            |
| Lift             | 18"       | 16"       | 14"       | 12"       | 18"       | 18"           | 18"           | 16"           | 14"           | 12"           |
| Weight           | 119 lbs   | 115 lbs   | 112 lbs   | 108 lbs   | 142 lbs   | 173 lbs       | 180 lbs       | 176 lbs       | 170 lbs       | 164 lbs       |
| Base             | Flat      | Flat      | Flat      | Flat      | Flat      | Drop          | Drop          | Drop          | Drop          | Drop          |

# LEXCO 2,000 LB. LIFT TABLES & OPTIONAL CONVEYOR TOP



492204

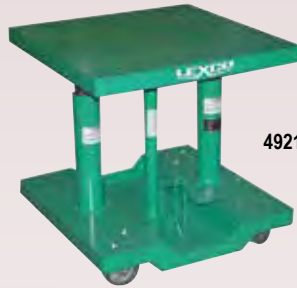

492199



499811  
(20" x 30" #492205 Table with #499206 Optional Push-Pull attached.)



## 2,000 lb. Capacity Foot Operated Hydraulic Lift Table

- **1-year warranty.**
- Precision telescoping guide tubes.
- 1/4" reinforced steel top and base.
- 5" diameter steel caster wheels.
- 2 rigid/2 swivel/1 floor lock on 20" x 30" and 30" x 30" models.
- 4 swivel casters/2 floor locks on 30" x 48" models.
- AC & DC power custom tables available. **Call for details.**
- Compatible with optional Push Pull Conveyor Top.
- **Push Pull Die Conveyor Top may be ordered separately without table or attached to table top at factory.**

| Part #          | 492204               | 492205               | 492206               | 492207               | 492208               | 492209               |
|-----------------|----------------------|----------------------|----------------------|----------------------|----------------------|----------------------|
| Model #         | HT-2338-2F           | HT-2388-2F           | HT-2368-2F           | HT-2346-2F           | HT-2324-2F           | HT-2302-2F           |
| Capacity        | 2,000 lbs            | 2,000 lbs            | 2,000 lbs            | 2,000 lbs            | 2,000 lbs            | 2,000 lbs            |
| Table Size      | 20" x 30"            | 20" x 30"            | 20" x 30"            | 20" x 30"            | 20" x 30"            | 20" x 30"            |
| Lowered Height  | 30"                  | 28"                  | 26"                  | 24"                  | 22"                  | 20"                  |
| Raised Height   | 48"                  | 46"                  | 44"                  | 40"                  | 36"                  | 32"                  |
| 5" Steel Caster | 2 rigid/<br>2 swivel | 2 rigid/<br>2 swivel | 2 rigid/<br>2 swivel | 2 rigid/<br>2 swivel | 2 rigid/<br>2 swivel | 2 rigid/<br>2 swivel |
| Lift            | 18"                  | 18"                  | 18"                  | 16"                  | 14"                  | 12"                  |
| Weight          | 215 lbs              | 216 lbs              | 224 lbs              | 220 lbs              | 213 lbs              | 208 lbs              |

**↓ TABLE WITH PUSH-PULL ATTACHED AT FACTORY ↓**

| Part #         | 499800      | 499811      | 499820      | 499821      | 499822      | 499823      |
|----------------|-------------|-------------|-------------|-------------|-------------|-------------|
| Model #        | HTP-2338-2F | HTP-2388-2F | HTP-2368-2F | HTP-2346-2F | HTP-2324-2F | HTP-2302-2F |
| Lowered Height | 33"         | 31"         | 29"         | 27"         | 25"         | 23"         |
| Raised Height  | 51"         | 49"         | 47"         | 43"         | 39"         | 35"         |

| Part #          | 492193               | 492199               | 492200               | 492201               | 492202               | 492203               | 492210               | 492211               | 492212               | 492213               | 492214               | 492215               |
|-----------------|----------------------|----------------------|----------------------|----------------------|----------------------|----------------------|----------------------|----------------------|----------------------|----------------------|----------------------|----------------------|
| Model #         | HT-3338-2F           | HT-3388-2F           | HT-3368-2F           | HT-3346-2F           | HT-3324-2F           | HT-3302-2F           | HT-3438-2F           | HT-3488-2F           | HT-3468-2F           | HT-3446-2F           | HT-3424-2F           | HT-3402-2F           |
| Capacity        | 2,000 lbs            | 2,000 lbs            | 2,000 lbs            | 2,000 lbs            | 2,000 lbs            | 2,000 lbs            | 2,000 lbs            | 2,000 lbs            | 2,000 lbs            | 2,000 lbs            | 2,000 lbs            | 2,000 lbs            |
| Table Size      | 30" x 30"            | 30" x 30"            | 30" x 30"            | 30" x 30"            | 30" x 30"            | 30" x 30"            | 30" x 48"            | 30" x 48"            | 30" x 48"            | 30" x 48"            | 30" x 48"            | 30" x 48"            |
| Lowered Height  | 30"                  | 28"                  | 26"                  | 24"                  | 22"                  | 20"                  | 30"                  | 28"                  | 26"                  | 24"                  | 22"                  | 20"                  |
| Raised Height   | 48"                  | 46"                  | 44"                  | 40"                  | 36"                  | 32"                  | 48"                  | 46"                  | 44"                  | 40"                  | 36"                  | 32"                  |
| 5" Steel Caster | 2 rigid/<br>2 swivel | 2 rigid/<br>2 swivel | 2 rigid/<br>2 swivel | 2 rigid/<br>2 swivel | 2 rigid/<br>2 swivel | 2 rigid/<br>2 swivel | 2 rigid/<br>2 swivel | 2 rigid/<br>2 swivel | 2 rigid/<br>2 swivel | 2 rigid/<br>2 swivel | 2 rigid/<br>2 swivel | 2 rigid/<br>2 swivel |
| Lift            | 18"                  | 18"                  | 18"                  | 16"                  | 14"                  | 12"                  | 18"                  | 18"                  | 18"                  | 16"                  | 14"                  | 12"                  |
| Weight          | 276 lbs              | 274 lbs              | 284 lbs              | 280 lbs              | 274 lbs              | 268 lbs              | 460 lbs              | 472 lbs              | 482 lbs              | 478 lbs              | 472 lbs              | 466 lbs              |

**↓ TABLE WITH PUSH-PULL ATTACHED AT FACTORY ↓**

| Part #         | 499824      | 499825      | 499826      | 499827      | 499828      | 499829      | 499830      | 499831      | 499832      | 499833      | 499834      | 499835      |
|----------------|-------------|-------------|-------------|-------------|-------------|-------------|-------------|-------------|-------------|-------------|-------------|-------------|
| Model #        | HTP-3338-2F | HTP-3388-2F | HTP-3368-2F | HTP-3346-2F | HTP-3324-2F | HTP-3302-2F | HTP-3438-2F | HTP-3488-2F | HTP-3468-2F | HTP-3446-2F | HTP-3424-2F | HTP-3402-2F |
| Lowered Height | 33"         | 31"         | 29"         | 27"         | 25"         | 23"         | 33"         | 31"         | 29"         | 27"         | 25"         | 23"         |
| Raised Height  | 51"         | 49"         | 47"         | 43"         | 39"         | 35"         | 51"         | 49"         | 47"         | 43"         | 39"         | 35"         |

## Optional Manual Push-Pull Conveyor Tops (Top only/without table.)

- **Optional top only, mounted on 1/4" steel plate. Table not included.**
- **1-year warranty.**
- Easier method for pushing and pulling loads to and from the unit.

- 5-lb. effort required to crank the handle.
- Sold as stand alone unit or assembled onto table.
- **Fits only 2,000 lb Lexco Model HT Lift Tables.**
- Fits 3 sizes of table tops: 20" x 30", 30" x 30" and 30" x 48" only.
- Drilling and layout required if purchased without table.

| Part #               | 499206    | 499235    | 499237    |
|----------------------|-----------|-----------|-----------|
| Model #              | 1098      | 1106      | SP-5746   |
| Capacity             | 2,000 lbs | 2,000 lbs | 2,000 lbs |
| Fits Table Top W x L | 20" x 30" | 30" x 30" | 30" x 48" |
| Max. Die Size W x L  | 20" x 23" | 30" x 23" | 30" x 41" |
| Direction of Travel  | 30"       | 30"       | 48"       |
| Weight               | 123 lbs   | 143 lbs   | 225 lb    |



Photo illustrates Optional #499206 Push-Pull top. TABLE NOT INCLUDED.

# LEXCO HYDRAULIC PRECISION LIFT TABLES

## 3,000 - 6,000 lb. Foot Operated or Powered Portable Hydraulic Lift Tables

- 1-year warranty.
- AC and DC power options available.
- 1/4" steel top and base.
- 2 rigid and 2 swivel steel wheel casters.
- Standard designs available in 2 sizes: 30" x 30" and 48" x 30".
- Available in 4 capacities: 3,000, 4,000, 5,000 and 6,000.
- Precision telescoping guide tubes.
- Stabilizers included on 4,000, 5,000 and 6,000 models.



HT-3043-23

### 30" x 30" Tables

| Part #              | 496043     | 496044     | 496045     | 496046     | 496047     | 496048     | 496049     | 496050     | 496051     | 496038     |
|---------------------|------------|------------|------------|------------|------------|------------|------------|------------|------------|------------|
| Model #             | HT-3033-23 | HT-3033-22 | HT-3033-20 | HT-3033-18 | HT-3033-16 | HT-3034-23 | HT-3034-22 | HT-3034-20 | HT-3034-18 | HT-3034-16 |
| Capacity            | 3,000 lbs  | 3,000 lbs  | 3,000 lbs  | 3,000 lbs  | 3,000 lbs  | 4,000 lbs  | 4,000 lbs  | 4,000 lbs  | 4,000 lbs  | 4,000 lbs  |
| Table Size          | 30" x 30"  | 30" x 30"  | 30" x 30"  | 30" x 30"  | 30" x 30"  | 30" x 30"  | 30" x 30"  | 30" x 30"  | 30" x 30"  | 30" x 30"  |
| Raised Height       | 54"        | 52"        | 48"        | 44"        | 40"        | 54"        | 52"        | 48"        | 44"        | 40"        |
| Lowered Height      | 31"        | 30"        | 28"        | 26"        | 24"        | 31"        | 30"        | 28"        | 26"        | 24"        |
| Casters             | 6"         | 6"         | 6"         | 6"         | 6"         | 6"         | 6"         | 6"         | 6"         | 6"         |
| Weight - Foot Pedal | 437 lbs    | 433 lbs    | 423 lbs    | 413 lbs    | 402 lbs    | 448 lbs    | 444 lbs    | 433 lbs    | 423 lbs    | 407 lbs    |
| Weight - Electric   | 488 lbs    | 484 lbs    | 474 lbs    | 464 lbs    | 498 lbs    | 499 lbs    | 495 lbs    | 484 lbs    | 474 lbs    | 458 lbs    |

| Part #              | 496052     | 496053     | 496054     | 496055     | 496056     | 496057     | 496058     | 496059     | 496060     | 496061     |
|---------------------|------------|------------|------------|------------|------------|------------|------------|------------|------------|------------|
| Model #             | HT-3035-23 | HT-3035-22 | HT-3035-20 | HT-3035-18 | HT-3035-16 | HT-3036-23 | HT-3036-22 | HT-3036-20 | HT-3036-18 | HT-3036-16 |
| Capacity            | 5,000 lbs  | 5,000 lbs  | 5,000 lbs  | 5,000 lbs  | 5,000 lbs  | 6,000 lbs  | 6,000 lbs  | 6,000 lbs  | 6,000 lbs  | 6,000 lbs  |
| Table Size          | 30" x 30"  | 30" x 30"  | 30" x 30"  | 30" x 30"  | 30" x 30"  | 30" x 30"  | 30" x 30"  | 30" x 30"  | 30" x 30"  | 30" x 30"  |
| Raised Height       | 54"        | 52"        | 48"        | 44"        | 40"        | 54"        | 52"        | 48"        | 44"        | 40"        |
| Lowered Height      | 31"        | 30"        | 28"        | 26"        | 24"        | 31"        | 30"        | 28"        | 26"        | 24"        |
| Casters             | 6"         | 6"         | 6"         | 6"         | 6"         | 6"         | 6"         | 6"         | 6"         | 6"         |
| Weight - Foot Pedal | 476 lbs    | 472 lbs    | 461 lbs    | 451 lbs    | 435 lbs    | 480 lbs    | 476 lbs    | 465 lbs    | 454 lbs    | 437 lbs    |
| Weight - Electric   | 527 lbs    | 523 lbs    | 512 lbs    | 502 lbs    | 486 lbs    | 531 lbs    | 527 lbs    | 516 lbs    | 505 lbs    | 488 lbs    |

### 48" x 30" Tables

| Part #              | 496062     | 496063     | 496064     | 496065     | 496066     | 496067     | 496068     | 496069     | 496070     | 496071     |
|---------------------|------------|------------|------------|------------|------------|------------|------------|------------|------------|------------|
| Model #             | HT-3043-23 | HT-3043-22 | HT-3043-20 | HT-3043-18 | HT-3043-16 | HT-3044-23 | HT-3044-22 | HT-3044-20 | HT-3044-18 | HT-3044-16 |
| Capacity            | 3,000 lbs  | 3,000 lbs  | 3,000 lbs  | 3,000 lbs  | 3,000 lbs  | 4,000 lbs  | 4,000 lbs  | 4,000 lbs  | 4,000 lbs  | 4,000 lbs  |
| Table Size          | 48" x 30"  | 48" x 30"  | 48" x 30"  | 48" x 30"  | 48" x 30"  | 48" x 30"  | 48" x 30"  | 48" x 30"  | 48" x 30"  | 48" x 30"  |
| Raised Height       | 54"        | 52"        | 48"        | 44"        | 40"        | 54"        | 52"        | 48"        | 44"        | 40"        |
| Lowered Height      | 31"        | 30"        | 28"        | 26"        | 24"        | 31"        | 30"        | 28"        | 26"        | 24"        |
| Casters             | 6"         | 6"         | 6"         | 6"         | 6"         | 6"         | 6"         | 6"         | 6"         | 6"         |
| Weight - Foot Pedal | 555 lbs    | 551 lbs    | 540 lbs    | 530 lbs    | 520 lbs    | 568 lbs    | 563 lbs    | 553 lbs    | 543 lbs    | 526 lbs    |
| Weight - Electric   | 606 lbs    | 602 lbs    | 591 lbs    | 581 lbs    | 571 lbs    | 619 lbs    | 614 lbs    | 604 lbs    | 594 lbs    | 577 lbs    |

| Part #              | 496072     | 496073     | 496074     | 496075     | 496076     | 496077     | 496078     | 496079     | 496080     | 496081     |
|---------------------|------------|------------|------------|------------|------------|------------|------------|------------|------------|------------|
| Model #             | HT-3045-23 | HT-3045-22 | HT-3045-20 | HT-3045-18 | HT-3045-16 | HT-3046-23 | HT-3046-22 | HT-3046-20 | HT-3046-18 | HT-3046-16 |
| Capacity            | 5,000 lbs  | 5,000 lbs  | 5,000 lbs  | 5,000 lbs  | 5,000 lbs  | 6,000 lbs  | 6,000 lbs  | 6,000 lbs  | 6,000 lbs  | 6,000 lbs  |
| Table Size          | 48" x 30"  | 48" x 30"  | 48" x 30"  | 48" x 30"  | 48" x 30"  | 48" x 30"  | 48" x 30"  | 48" x 30"  | 48" x 30"  | 48" x 30"  |
| Raised Height       | 54"        | 52"        | 48"        | 44"        | 40"        | 54"        | 52"        | 48"        | 44"        | 40"        |
| Lowered Height      | 31"        | 30"        | 28"        | 26"        | 24"        | 31"        | 30"        | 28"        | 26"        | 24"        |
| Casters             | 6"         | 6"         | 6"         | 6"         | 6"         | 6"         | 6"         | 6"         | 6"         | 6"         |
| Weight - Foot Pedal | 600 lbs    | 596 lbs    | 585 lbs    | 575 lbs    | 559 lbs    | 604 lbs    | 600 lbs    | 589 lbs    | 578 lbs    | 562 lbs    |
| Weight - Electric   | 651 lbs    | 647 lbs    | 636 lbs    | 626 lbs    | 610 lbs    | 655 lbs    | 651 lbs    | 640 lbs    | 629 lbs    | 613 lbs    |

Other sizes also available. Call for details.

- 30" wide x 60", 72", 96" and 120" long.
- 36" wide x 60", 72", 96" and 120" long.
- 48" wide x 60", 72", 96" and 120" long.
- These sizes with 2 rigid and 2 swivel 8" diameter steel wheel casters and two floor locks.



SINCE 1948



## 2,000 lb. Capacity Long-Deck Hydraulic Foot-Operated Lift Tables

- 1-year warranty.
- AC and DC power options available.
- Standard lift height 30" - 48".
- Optional lift ranges available, call factory.
- 10 gauge steel top.



- Foot operated.
- Precision telescoping guide tubes.
- 4 swivel 5" diameter steel wheels or optional polyurethane wheels.
- 2 floor locks.

Call for information on powered models.

| Part #         | 492239      | 492240      | 492241      | 492242      | 492128      | 492129      | 492130      | 492131      |
|----------------|-------------|-------------|-------------|-------------|-------------|-------------|-------------|-------------|
| Model #        | STN-2005-2F | STN-2006-2F | STN-2008-2F | STN-2010-2F | STN-3005-2F | STN-3006-2F | STN-3008-2F | STN-3010-2F |
| Capacity       | 2,000 lbs   | 2,000 lbs   | 2,000 lbs   | 2,000 lbs   | 2,000 lbs   | 2,000 lbs   | 2,000 lbs   | 2,000 lbs   |
| Table Size     | 5' x 20"    | 6' x 20"    | 8' x 20"    | 10' x 20"   | 5' x 30"    | 6' x 30"    | 8' x 30"    | 10' x 30"   |
| Raised Height  | 48"         | 48"         | 48"         | 48"         | 48"         | 48"         | 48"         | 48"         |
| Lowered Height | 30"         | 30"         | 30"         | 30"         | 30"         | 30"         | 30"         | 30"         |
| Casters        | 5"          | 5"          | 5"          | 5"          | 5"          | 5"          | 5"          | 5"          |
| Weight         | 384 lbs     | 400 lbs     | 459 lbs     | 505 lbs     | 423 lbs     | 457 lbs     | 512 lbs     | 568 lbs     |

Call for information on powered models.

## 3,000 & 5,000 lb. Capacity Long-Deck Hydraulic Foot-Operated Lift Tables

- 1-year warranty.
- AC and DC power options available.
- Load stabilizer assembly on 5,000 lb models.
- 2 floor locks.
- Precision telescoping guide tubes.
- Table top 3,000 lb. models: .25" thick steel.
- Table top 5,000 lb. models: .25" thick steel.



STN-3608-5F  
With Load Stabilizer

| Part #         | 492250                        | 492251                        | 492252                        | 492253                        | 492254   | 492255   | 492256   | 492257   |
|----------------|-------------------------------|-------------------------------|-------------------------------|-------------------------------|--|--|--|--|
| Model #        | STN-3605-3F                   | STN-3606-3F                   | STN-3608-3F                   | STN-3610-3F                   | STN-3605-5F                                    | STN-3606-5F                                    | STN-3608-5F                                    | STN-3610-5F                                    |
| Capacity       | 3,000 lbs                     | 3,000 lbs                     | 3,000 lbs                     | 3,000 lbs                     | 5,000 lbs                                      | 5,000 lbs                                      | 5,000 lbs                                      | 5,000 lbs                                      |
| Table Size     | 5' x 36"                      | 6' x 36"                      | 8' x 36"                      | 10' x 36"                     | 5' x 36"                                       | 6' x 36"                                       | 8' x 36"                                       | 10' x 36"                                      |
| Raised Height  | 56.375"                       | 56.375"                       | 56.375"                       | 56.375"                       | 53.125"  | 53.125"  | 53.125"  | 53.125"  |
| Lowered Height | 36.375"                       | 36.375"                       | 36.375"                       | 36.375"                       | 33.125"  | 33.125"  | 33.125"  | 33.125"  |
| Casters        | 8" steel wheels<br>4 / swivel | 8" steel wheels<br>4 / swivel | 8" steel wheels<br>4 / swivel | 8" steel wheels<br>4 / swivel | 8" steel wheels<br>2 swivel & brake<br>2 rigid | 8" steel wheels<br>2 swivel & brake<br>2 rigid | 8" steel wheels<br>2 swivel & brake<br>2 rigid | 8" steel wheels<br>2 swivel & brake<br>2 rigid |
| Weight         | 811 lbs                       | 846 lbs                       | 954 lbs                       | 1,026 lbs                     | 1,010 lbs                                      | 1,074 lbs                                      | 1,397 lbs                                      | 1,486 lbs                                      |

The DH series hydraulic die handler is a cost effective mobile die cart that allows you to transport, separate, and present your dies for service and maintenance.

## 2,000, 3,000 & 4,000 lb. Capacity Die Handlers

- 1-year warranty.
- Heavy-duty steel adjustable clamps for gripping the upper die set for separation.
- Floor lock.
- Precision telescoping guide tubes.
- Rigid die hangers with 360° indexing plate.
- Optional gantry heights available upon request.



Call for information on powered models.



Model DH-3005-43

| Part #                                   | 499243                   | 499244         | 499245         | 499246                   |
|--|--------------------------|----------------|----------------|--------------------------|
| Model #                                  | DH-3339-22               | DH-3438-24     | DH-3043-22     | DH-3005-43               |
| Capacity                                 | 2,000lbs                 | 2,000lbs       | 3,000 lbs      | 4,000 lbs                |
| Table Top W x L                          | 30" x 30"                | 30" x 48"      | 30" x 48"      | 30" x 60"                |
| Raised Height                            | 48"                      | 48"            | 52"            | 55"                      |
| Lowered Height                           | 30"                      | 30"            | 30"            | 32"                      |
| Minimum Clearance under Bar to Table Top | 19.885"                  | 19.885"        | 20.5"          | 20.5"                    |
| Caster Size/ Type                        | 5"<br>2 swivel / 2 rigid | 5"<br>4 swivel | 6"<br>4 swivel | 8"<br>2 swivel / 2 rigid |
| Max. Die Size                            | 30" x 24"                | 42" x 30"      | 42" x 30"      | 54" x 30"                |
| Weight                                   | 388 lbs                  | 590 lbs        | 747 lbs        | 1,069 lbs                |

## Precision Lift Tables

- 1/4" heavy duty welded steel construction
- Durable powder coat finish
- Long 13" crank handle for heavy loads.
- Handle positions at both table ends for optimum flexibility
- Two Lift Speeds:
  - 1/8" lift per rotation for heavy loads or precise load positioning
  - 1/4" lift per rotation for fast lift or light loads
- Heavy duty floor lock and locking swivel casters are standard
- Choice of cast iron or poly casters



Part #274680



OVERALL DIMENSIONS

|          |       |       |       |
|----------|-------|-------|-------|
| w: 31.5" | 31.5" | 31.5" | 31.5" |
| h: 25.6" | 25.6" | 25.6" | 25.6" |
| d: 37.8" | 37.8" | 49.2" | 49.2" |

| Part #            | 274680                           | 274683                           | 274681                           | 274684                           |
|-------------------|----------------------------------|----------------------------------|----------------------------------|----------------------------------|
| Model #           | HCLT-2436-P                      | HCLT-2436-CI                     | HCLT-3048-P                      | HCLT-3048-CI                     |
| Capacity          | 2,200 lbs.                       | 2,200 lbs.                       | 2,200 lbs.                       | 2,200 lbs.                       |
| Table W x L       | 24" x 36"                        | 24" x 36"                        | 30" x 48"                        | 30" x 48"                        |
| Raised Height     | 42"                              | 42"                              | 42"                              | 42"                              |
| Lowered Height    | 24"                              | 24"                              | 24"                              | 24"                              |
| Wheel             | Poly                             | Cast Iron                        | Poly                             | Cast Iron                        |
| Caster Size/ Type | 5"<br>2 rigid / 2 swivel w/brake | 5"<br>2 rigid / 2 swivel w/brake | 6"<br>2 rigid / 2 swivel w/brake | 8"<br>2 rigid / 2 swivel w/brake |
| Weight            | 132 lbs.                         | 132 lbs.                         | 143 lbs.                         | 143 lbs.                         |



## Folding Handle Scissors Lift Table

- Folding handle lays flat on table top.
- Chrome plated handle and foot pedal.
- Lever release handle.
- Moldon polyurethane wheels and locking swivel casters.
- Foot operated pump.

### OVERALL DIMENSIONS

|           |     |       |     |
|-----------|-----|-------|-----|
| w: 17.75" | 20" | 19.5" | 20" |
| h: 37"    | 39" | 39"   | 39" |
| d: 36"    | 37" | 42"   | 37" |



## Fixed Handle Scissors Tables

- Fixed handle.
- Foot operated pump.
- Easy to use spring loaded release lever.
- 5" x 1.5" moldon polyurethane wheels and locking casters.

### OVERALL DIMENSIONS

|          |       |
|----------|-------|
| w: 19.5" | 19.5" |
| h: 37"   | 37"   |
| d: 42"   | 42"   |



## Double Scissors High Lift Tables

- Fixed handle.
- Chrome plated handle and foot pedal.
- Lever release handle.
- 5" x 1.5" moldon polyurethane wheels and locking swivel casters.
- Foot operated pump.

### OVERALL DIMENSIONS

|          |     |
|----------|-----|
| w: 19.5" | 24" |
| h: 37"   | 37" |
| d: 45.5" | 58" |



## Heavy Duty Scissors Lift Tables

- Fixed handle.
- Chrome plated handle and foot pedal.
- 5" x 2" moldon polyurethane wheels and locking swivel casters.
- Foot operated pump.

### OVERALL DIMENSIONS

|          |       |
|----------|-------|
| w: 20"   | 20"   |
| h: 39.5" | 39.5" |
| d: 49"   | 50"   |

| Part #              | 260201         | 260207     | 272974      | 260208      | 260199      | 260200      | 260204        | 272862     | 272970    | 272973    |
|---------------------|----------------|------------|-------------|-------------|-------------|-------------|---------------|------------|-----------|-----------|
| Model #             | LT-330SL       | SLT-660-11 | LT-660FHSL  | SLT-1100-11 | LT-700SL    | LT-1000SL   | LT-770DSL     | LT-1540DSL | LT-1650SL | LT-2200SL |
| Capacity            | 330 lbs        | 660 lbs    | 660 lbs     | 1,100 lbs   | 700 lbs     | 1,000 lbs   | 770 lbs       | 1,540 lbs  | 1,650 lbs | 2,200 lbs |
| Table Size          | 17.75" x 27.5" | 20" x 32"  | 19.5" x 32" | 20" x 32"   | 19.5" x 32" | 19.5" x 32" | 19.5" x 35.5" | 24" x 48"  | 20" x 39" | 20" x 40" |
| Raised Height       | 28.5"          | 35"        | 35"         | 35"         | 35"         | 35"         | 51"           | 59"        | 35.5"     | 39"       |
| Lowered Height      | 8.5"           | 11"        | 14"         | 11"         | 14"         | 14"         | 14"           | 17.75"     | 16.5"     | 15"       |
| Caster Size         | 4" x 1"        | 5" x 1.5"  | 5" x 1.5"   | 5" x 1.5"   | 5" x 1.5"   | 5" x 1.5"   | 5" x 1.5"     | 5" x 1.5"  | 5" x 2"   | 5" x 2"   |
| Locking Caster (LC) | LC             | LC         | LC          | LC          | LC          | LC          | LC            | LC         | LC        | LC        |
| Weight              | 98 lbs         | 165 lbs    | 170 lbs     | 187 lbs     | 170 lbs     | 185 lbs     | 227 lbs       | 430 lbs    | 276 lbs   | 269 lbs   |

## TABLE TOP SIZES

**32" WIDE X 63" LONG**  
**30" WIDE X 80" LONG**



273261



Manually operated safety bars lock table in raised position.

### Long Deck Scissors Table

- Oversized **63" long** x 32" wide and **80" long** x 30" wide table tops accommodate large cargo.
- Two wheels and two locking swivel casters.
- Handle height - 38" (32" x 63" table) 39" (30" x 80" table).
- Hydraulic foot pump.
- Safety bars.
- Table top thickness: .125" (3mm).

#### OVERALL DIMENSIONS

|           |         |
|-----------|---------|
| w: 32"    | 34.5"   |
| h: 38"    | 53.5"   |
| d: 74.25" | 80.125" |



273269



### Scissors Table with Roller Top

- Roller top permits easy movement of cargo for loading and unloading.
- Two locking swivel casters - 5" x 1 1/2" moldon polyurethane.
- Two 5" x 1 1/2" moldon polyurethane casters.
- Handle height - 38 1/4".
- Two dual-position end stops help keep cargo in place.
- Eight 2" diameter rollers 18 1/2" long.
- Hydraulic foot pump.
- Variable lowering speed valve.

#### OVERALL DIMENSIONS

|           |
|-----------|
| w: 20.25" |
| h: 38.25" |
| d: 43"    |



273265

### Hydraulic Die Lift Table

- Table top size - 24" x 36".
- Handle height - 36.75".
- Two swivel locking casters - 5" x 1 1/2" moldon polyurethane.
- Hydraulic foot pump.
- Removable handle - may also be reversed for use in confined areas.
- Variable lowering speed.

#### OVERALL DIMENSIONS

|           |
|-----------|
| w: 24"    |
| h: 36.75" |
| d: 49.5"  |

| Part #           | 273261                        | 273230                               | 273269        | 273265    |
|------------------|-------------------------------|--------------------------------------|---------------|-----------|
| Model #          | LDT-3263                      | LDT-3080                             | DRT-2033      | DT-2436   |
| Capacity         | 1,100 lbs                     | 2,200 lbs                            | 660 lbs       | 2,000 lbs |
| Table Size       | <b>32" x 63"</b>              | <b>30" x 80"</b>                     | 19.5" x 32.5" | 24" x 36" |
| Raised Height    | 36"                           | 53.5"                                | 38.25"        | 36"       |
| Lowered Height   | 11.25"                        | 14.2"                                | 12.5"         | 24.25"    |
| Caster Size/Type | 5" x 1.5" Moldon Polyurethane | Nylon 3" x 1.5" swivel 7" x 2" wheel | 5" x 1.5"     | 5" x 1.5" |
| Weight           | 340 lbs                       | 440 lbs                              | 210 lbs       | 265 lbs   |





273710



273713



273711



273712



270662



### Powered Lift Scissors Table

- 12 volt rechargeable, deep cycle batteries with onboard charger and battery gauge.
- Moldon polyurethane wheels and locking swivel casters.
- Chrome plated handle.
- Keyed on/off switch.
- Raised-height limit switch.
- Push-button pendant can be removed for hand held operation.
- Overload bypass valve.
- Emergency stop button.

#### OVERALL DIMENSIONS

|           |       |        |         |
|-----------|-------|--------|---------|
| w: 19.75" | 20.5" | 24.5"  | 19.625" |
| h: 36"    | 38"   | 36.25" | 36"     |
| d: 45.25" | 52"   | 53.75" | 47.75"  |

### Mini Electric Lift Table

- Heavy duty to handle tough loads.
- Small and light enough to move.
- Full perimeter safety bar stops table from lowering if it contacts an obstruction.
- 110V 60 Hz.
- Push button station.

#### OVERALL DIMENSIONS

|        |
|--------|
| w: 24" |
| h: 30" |
| d: 35" |

| Part #            | 273710              | 273711                 | 273712              | 273713                       | 270662    |
|-------------------|---------------------|------------------------|---------------------|------------------------------|-----------|
| Model #           | PSLT-660            | PSLT-1100              | PSLT-1650           | PSLT-770-DS                  | MELT      |
| Capacity          | 660 lbs             | 1,100 lbs              | 1,650 lbs           | 770 lbs<br>(Double Scissors) | 2,200 lbs |
| Table Size W x L  | 19.75" x 33.5" x 2" | 20.5" x 39.75" x 2.25" | 20" x 39.5" x 2.25" | 19.625" x 35.875" x 2.25"    | 24" x 35" |
| Raised Height     | 34.25"              | 40.5"                  | 39.5"               | 51.5"                        | 30"       |
| Lowered Height    | 11.25"              | 17.25"                 | 17"                 | 14.5"                        | 7"        |
| Caster Size       | 5" x 1.25"          | 6" x 1.5"              | 6" x 2"             | 5" x 1.25"                   | N/A       |
| Qty. of batteries | 4                   | 2                      | 4                   | 4                            | N/A       |
| Weight            | 256 lbs             | 346 lbs                | 353 lbs             | 300 lbs                      | 283 lbs   |



272986



### Protective Skirt - Part # 275001

- Option must be ordered as a separate item.
- Only available as factory installed.
- Fits both spring and pneumatic pallet levelers.

### Pallet Leveler

- The pallet leveler progressively lowers as pallet is loaded and raises as pallet is unloaded.
- 3 Heavy duty calibrated springs used in combination according to desired load range.
- Bearing supported carousel for easy turning.
- Built in fork pockets for ease of transport.
- Helps reduce fatigue and injury from bending and lifting.

#### OVERALL DIMENSIONS

w: 36"  
h: 9.25" Compressed / 29" Raised  
d: 45.5"



272696

### Pneumatic Pallet Leveler

- The pneumatic pallet leveler progressively lowers as pallet is loaded and raises as pallet is unloaded.
- Pneumatic bellows actuates raising and lowering of loads.
- 80 PSI of initial air pressure required.
- Air tank and controls are self-contained and do not require constant air pressure.
- Removable tank and controls for remote operation; 48" of hose included.

#### OVERALL DIMENSIONS

w: 36"  
h: 12.55" Compressed / 28.5" Raised  
d: 45.5"

| Part #                 | 272986          | 272696               |
|------------------------|-----------------|----------------------|
| Model #                | PL              | PPL                  |
| Capacity               | 400-4,500 lbs   | 4,500 lb maximum     |
| Raised Height          | 29"             | 28.5" (without load) |
| Lowered Height         | 9.25"           | 12.5"                |
| Carousel Diameter      | 40.75"          | 40.75"               |
| Rotating Ring Diameter | 43.5"           | 43.5"                |
| Fork Pocket L x W      | 39" x 5.75"     | 39" x 5.75"          |
| Load Size              | 72" x 50" x 50" | 72" x 50" x 50"      |
| Weight                 | 352 lbs         | 322 lbs              |

**A 5 Year Guarantee Against Weld Failure. A Wesco Quality Exclusive.**

**Features:**

- Heavy duty capacities up to 5 tons - the most economical way to lift and move large bulky loads.
- Swivel casters allow movement in any direction.
- Hand operated hydraulic jack for easy lifting and controlled lowering of loads.
- All models supplied with hooks for recommended optional LB-1 or LB-2 load binders.



RNR-2



RNR-4



**Rais-N-Rol™  
2,000 lb  
Capacity  
Per Pair**

- 23" wide x 13.25" deep x 47.25" high (lowered height).
- I.D. fork span range 7.25" to 17.5".

**OVERALL  
DIMENSIONS**

w: 23"  
h: 47.25"  
d: 15.25"



**Rais-N-Rol™  
4,000 lb  
Capacity  
Per Pair**

- 23" wide x 16.875" deep x 43.5" high (lowered height).
- I.D. fork span range 5" to 19.5".

**OVERALL  
DIMENSIONS**

w: 23"  
h: 43.5"  
d: 18.5"



RNR-6P

**Rais-N-Rol™ 6,000 lb  
Capacity Per Pair**

- 23" wide x 16.875" deep.
- RNR-6(P): 43.5" H; RNR-64(P): 43.5" H.
- I.D. fork span range 6" to 19.5".

**OVERALL  
DIMENSIONS**

w: 23"  
h: 43.5"  
d: 18.375"



RNR-8



RNR-10



**Rais-N-Rol™  
8,000 lb  
Capacity  
Per Pair**

- 24" wide x 18.625" deep x 47" high (lowered height).
- I.D. fork span range 6" to 19.5".

**OVERALL  
DIMENSIONS**

w: 24"  
h: 47"  
d: 21.75"



**Rais-N-Rol™  
10,000 lb  
Capacity  
Per Pair**

- 24" wide x 18.625" deep x 47" high (lowered height).
- I.D. fork span range 6" to 19.5".

**OVERALL  
DIMENSIONS**

w: 24"  
h: 47"  
d: 21.75"

| Part #   | 260086              | 260091                  | 260087           | 260092                  | 260088             | 260093                    | 260138             | 260139                    | 260089             | 260094                  | 260090             | 260095                  |
|----------|---------------------|-------------------------|------------------|-------------------------|--------------------|---------------------------|--------------------|---------------------------|--------------------|-------------------------|--------------------|-------------------------|
| Model #  | RNR-2               | RNR-2P                  | RNR-4            | RNR-4P                  | RNR-6              | RNR-6P                    | RNR-64             | RNR-64P                   | RNR-8              | RNR-8P                  | RNR-10             | RNR-10P                 |
| Capacity | 2,000 lbs           | 2,000 lbs               | 4,000 lbs        | 4,000 lbs               | 6,000 lbs          | 6,000 lbs                 | 6,000 lbs          | 6,000 lbs                 | 8,000 lbs          | 8,000 lbs               | 10,000 lbs         | 10,000 lbs              |
| Lift     | 5"                  | 5"                      | 12"              | 12"                     | 12"                | 12"                       | 12"                | 12"                       | 6"                 | 6"                      | 6"                 | 6"                      |
| Casters  | 5" x 2"<br>Phenolic | 5" x 2"<br>Polyurethane | 6" x 2"<br>Steel | 6" x 2"<br>Polyurethane | 6" x 2.5"<br>Steel | 6" x 2.5"<br>Polyurethane | 6" x 2.5"<br>Steel | 6" x 2.5"<br>Polyurethane | 8" x 2.5"<br>Steel | 8" x 3"<br>Polyurethane | 8" x 2.5"<br>Steel | 8" x 3"<br>Polyurethane |
| Weight   | 170 lbs/PR          | 176 lbs/PR              | 315 lbs/PR       | 313 lbs/PR              | 325 lbs/PR         | 306 lbs/PR                | 359 lbs/PR         | 359 lbs/PR                | 390 lbs/PR         | 402 lbs/PR              | 480 lbs/PR         | 475 lbs/PR              |

**Option: Load  
Binder Accessory**



LB-1

- Two 12' long nylon belts with heavy duty ratchet tighteners.
- Highly recommended for stabilizing large loads.

| Part   | Model # | Description                               |
|--------|---------|---|
| 260096 | LB-1    | Delta rings secure belt to Rais-N-Rol     |
| 260147 | LB-2    | "E" track hooks secure belt to Rais-N-Rol |

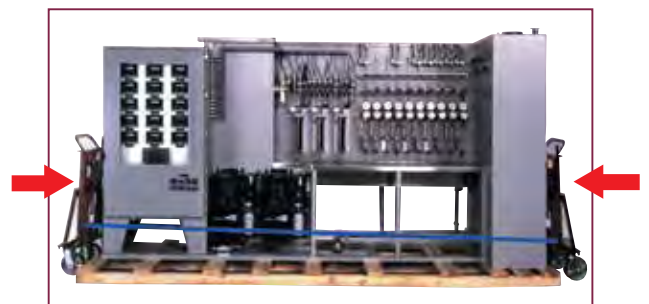

Panel becomes its own dolly.

## Furniture Mover

- Sold in pairs only.
- Two models: Manual Lift / Hydraulic Lift
- Economically priced.
- Great for moving furniture or odd shaped loads.
- Straps to secure load standard.
- Hydraulic unit with ratcheting strap tightener.
- 6" swivel casters.



Hydraulic  
272952



Manual  
272951

### OVERALL DIMENSIONS

|    |     |       |
|----|-----|-------|
| w: | 23" | 26.5" |
| h: | 32" | 42"   |
| d: | 15" | 16"   |

| Part #           | 272951                 | 272952                 |
|------------------|------------------------|------------------------|
| Model #          | MFM                    | HFM                    |
| Capacity         | 1,320 lbs per pair     | 3,950 lbs per pair     |
| Lift Plate L x D | 8.5" x 4.5"            | 23" X 2.25"            |
| Lift Height      | 12"                    | 10"                    |
| Casters          | 6" Moldon Polyurethane | 6" Moldon Polyurethane |
| Weight           | 72 lbs                 | 195 lbs                |



*HeviMovers™ are made with precision ground and hardened steel rollers that form an endless chain which revolves around a central load-bearing plate in the frame. Weight of the load is transferred directly from load-bearing plate to rollers. This eliminates axle friction and requires less power to start and move the load. HeviMovers™ roll easily over cracks and pitted floor areas to reduce possible damage to goods.*



480020



480002



## HeviMover™ Kit #480019

- Includes 4 HMS-2 HeviMovers and 2 29" knocked down steering handles in a rugged steel tool box.

### OVERALL DIMENSIONS

|    |     |
|----|-----|
| w: | 16" |
| h: | 7"  |
| d: | 7"  |

## Steel Deck Machine Dolly

- .25" thick steel plate.
- 2" x .5" aircraft quality, heat treated steel wheels.

### OVERALL DIMENSIONS

|    |        |
|----|--------|
| w: | 8.5"   |
| h: | 2.5"   |
| d: | 11.75" |

## HeviMover™ Machine Rollers

- Swivel-top for maximum maneuverability, full 360° rotation.
- Spring-loaded locking mechanism at 45° intervals.
- Only periodic cleaning and light re-oiling of roller chain needed.

### OVERALL DIMENSIONS

|    |         |         |        |        |
|----|---------|---------|--------|--------|
| w: | 3.125"  | 5.5"    | 5.75"  | 6.5"   |
| h: | 3.1875" | 4.4375" | 4.875" | 4.875" |
| d: | 8"      | 10"     | 10.5"  | 12.75" |

| Part #          | 480020     | 480001    | 480002    | 480003     | 480004     | 480019                      |
|-----------------|------------|-----------|-----------|------------|------------|-----------------------------|
| Model #         | HMS-2      | HMS-8     | HMS-15    | HMS-30     |            | HMS-2K                      |
| Capacity        | 10,000 lbs | 2,000 lbs | 8,000 lbs | 15,000 lbs | 30,000 lbs | 4 HMS - 2's @ 2,000 lbs ea. |
| Wheel Size      | 2" x .5"   | N/A       | N/A       | N/A        | N/A        | N/A                         |
| Roller Width    | NA         | 1.875"    | 3.25"     | 3.25"      | 4"         | 1.875"                      |
| Roller Diameter | NA         | .6875"    | .9375"    | 1.1875"    | 1.1875"    | .6875"                      |
| Weight          | 11.5 lbs   | 10 lbs    | 31 lbs    | 39 lbs     | 52 lbs     | 55 lbs                      |

## HeviMover™ Options

- Steering handles.
- Turning bar.

| Part #      | 480005                        | 480006                        |
|-------------|-------------------------------|-------------------------------|
| Model #     | HMH-36-1                      | HMH-48-1                      |
| Description | 36" steering handle for HMS-2 | 48" steering handle for HMS-2 |
| Weight      | 6 lbs                         | 7 lbs                         |

| Part #      | 480007                                | 480008                                |
|-------------|---------------------------------------|---------------------------------------|
| Model #     | HMH-36-2                              | HMH-48-2                              |
| Description | 36" steering handle for HMS-8, 15, 30 | 48" steering handle for HMS-8, 15, 30 |
| Weight      | 6 lbs                                 | 7 lbs                                 |

| Part #      | 480009                            |
|-------------|-----------------------------------|
| Model #     | HMH-TB-2                          |
| Description | 36" turning bar for HMS-8, 15, 30 |
| Weight      | 14.5 lbs                          |