

Drum Handling Equipment

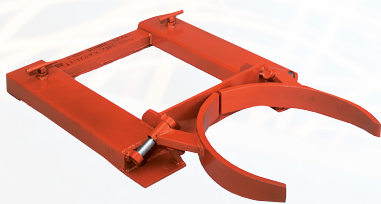

1-800-445-5681

www.wescomfg.com

www.lexcoeng.com



DRUM HANDLING EQUIPMENT

Drum Trucks - Steel, Aluminum, Stainless , 4-Wheel Drum Cart , KD Drum Truck, Stainless 626-D	3-6
Drum Dollies - Steel, Aluminum, Stainless Steel & Polypropylene, Pail Truck & Pail Tipper.....	7-8
Drum Trucks, Carriers, Dispensers	9
Drum Racks, Cradles.....	10
Drum Lifters, Steel & Stainless Steel , Drum Sling.....	11
Ergonomic Drum Lifters, Steel & Stainless Steel , Manual, Scale, Powered, High Reach	12
Ergonomic Drum Tilters, Steel, Manual, Powered, High Reach.....	13
Drum Dispensers, Triple Truck Drum Attachment.....	14
Gator Grip Drum Grab	15
Fork Drum Grabs, Fork Truck Drum Dispensers, Poly Drum Lifters	16
FM Approved Drum Faucets, Plastic Drum Faucets.....	17
FM Approved Drum Vent, Wires, Gauges, Funnel, Pop-Up Gauges	18
Drum Deheaders & Wrenches.....	19
Drum Pumps & Drip Pans, Stainless Steel Rotary Pump	20

A WESCO EXCLUSIVE
5 YEAR GUARANTEE

★ AGAINST WELD FAILURE ★

DRUM TRUCK FEATURES:

■ Heavy duty, double-welded joints.

■ 1" structural steel frame.

■ Kickstands to store upright.



5BT



5BTW

5BT & 5BTW Economy Series

- Kickstand.
- With wheels resting on floor, 22" to center of lowered chime hook.
- **Steel drums only.**
- Handles 55 & 85 gallon steel drums.

OVERALL DIMENSIONS

w: 24.5"
h: 62"
d: 17"



10BT



10BTW

10BT & 10BTW Standard Series

- Machined steel load wheels behind nose prongs help ease the lifting of the drum.
- With wheels resting on floor, 22" to center of lowered chime hook.
- **Steel drums only.**
- Handles 55 & 85 gallon steel drums.

OVERALL DIMENSIONS

w: 24.5"
h: 61"
d: 14.5"



15BT



15BT & 15BTW Deluxe Series

- Four wheel design enables user to quickly and easily load and unload drums from pallet.
- With two wheels resting on floor, 20.5" to center of lowered chime hook.
- Replaceable hard faced double-beveled nose prongs, Part # 240060.
- **Steel drums only.**
- Handles 30, 55 & 85 gallon steel drums.

OVERALL DIMENSIONS

w: 24"
h: 58"
d: 21"



6" x 2" Special swivel caster design for tight turning radius



15BTC

15BTC Ergonomic Drum Truck

- Ergonomic swivel caster design reduces operator muscle strain and fatigue.
- With two wheels resting on floor, 20.5" to center of lowered chime hook.
- Replaceable hard faced double-beveled nose prongs, Part # 240060.
- **Steel drums only.**
- Handles 30, 55 & 85 gallon steel drums.

OVERALL DIMENSIONS

w: 24"
h: 58"
d: 21"



20BT



20BT & 20BTW- Deluxe Series

- Floating axle reduces effort required to break over and balance load.
- Chime hook can be stored at the top of the frame for easy use.
- Replaceable hard faced double-beveled nose prongs, Part # 240060.
- **Steel drums only.**
- Handles 30, 55 & 85 gallon steel drums.

OVERALL DIMENSIONS

w: 23.5"
h: 60"
d: 17"



ERGONOMIC DESIGN

BEST IN CLASS: BRAKE-OVER FORCE

Part #	240009	240010	240013	240014	240001	240002	240121	240003	240004
Model #	5BT	5BTW	10BT	10BTW	15BT	15BTW	15BTC	20BT	20BTW
Capacity	1,000 lbs	1,000 lbs	1,000 lbs	1,000 lbs	1,000 lbs	1,000 lbs	1,000 lbs	1,000 lbs	1,000 lbs
10" Wheel	Moldon Rubber	Polyolefin	Moldon Rubber	Polyolefin	Moldon Rubber	Polyolefin	Moldon Rubber	Moldon Rubber	Polyolefin
6" Wheel	N/A	N/A	N/A	N/A	Moldon Rubber	Polyolefin	Moldon Rubber	N/A	N/A
Weight	68 lbs	53 lbs	64 lbs	50 lbs	79 lbs	61 lbs	79 lbs	74 lbs	59 lbs

BT
10" x 2.5"
Cast Iron Center
Moldon Rubber



150596



150691

DRUM HANDLING EQUIPMENT

DRUM TRUCK FEATURES:

- Heavy duty, double-welded joints.
- 1" structural steel frame.
- Self standing or with kick stand for upright storage.



30BT



6" x 1 1/2" wheel

30BT & 30BTW - Standard Series

- Multi-functional drum truck allows you to move drums on four wheels and acts as a drum cradle for storage or dispensing.
- 16.5" drain height.
- With two wheels resting on floor, 28" to bottom of lowered chime hook.
- **Steel drums only.**
- Handles 30, 55 & 85 gallon steel drums.

OVERALL DIMENSIONS

w: 24"
 h: 56"
 d: 20.5"



40BT



40BT & 40BTW Series

- Handles all poly and fiber drums except overpacks (use 45BT for overpacks).
- Replaceable feet - Part# 240115 and replaceable belt - Part# 150303.
- Floating axle reduces effort required to break over and balance load.
- With wheels resting on floor, 28" to bottom of belt.
- Handles 30, 55 & 85 gal. drums.
- **Steel, poly & fiber drums.**

OVERALL DIMENSIONS

w: 23.75"
 h: 59.75"
 d: 24"



45BT



45BT & 45BTW Series

- Recommended primarily for handling of overpacks.
- Wide "feet" eliminate the risk of drums being punctured by nose prongs.
- Replaceable feet - Part # 240115 and replaceable belt - Part # 150304.
- Floating axle reduces effort required to break over and balance load.
- With wheels resting on floor, 28" to center of belt.
- Handles 30, 55 & 85 gal. drums.
- **Steel, poly & fiber drums.**

OVERALL DIMENSIONS

w: 24"
 h: 59.75"
 d: 24"



50BT

Rear wheels on 50BT - Aluminum Ctr. Moldon Rubber
 Rear wheels on 50BTW - Polyolefin



50BT & 50BTW Series

- Acts as a Poly Drum Truck or Drain Stand.
- Wide "feet" and belt eliminate the risk of drums being punctured by nose prongs and chime hooks.
- With two wheels resting on floor, 32" to center of belt.
- Handles all poly drums (except overpacks).
- Handles 30, 55 & 85 gal. drums.
- **Steel, poly & fiber drums.**

OVERALL DIMENSIONS

w: 24"
 h: 57.5"
 d: 25"

Part #	240005	240006	240081	240076	240082	240077	240083	240078
Model #	30BT	30BTW	40BT	40BTW	45BT	45BTW	50BT	50BTW
Capacity	1,000 lbs	1,000 lbs	1,000 lbs	1,000 lbs	1,000 lbs	1,000 lbs	1,000 lbs	1,000 lbs
10" Wheel	Moldon Rubber	Polyolefin	Moldon Rubber	Polyolefin	Moldon Rubber	Polyolefin	Moldon Rubber	Polyolefin
6" Wheel	Moldon Rubber	Polyolefin	N/A	N/A	N/A	N/A	Moldon Rubber	Polyolefin
Weight	82 lbs	66 lbs	82 lbs	67 lbs	82 lbs	67 lbs	86 lbs	65 lbs

BT BTW
 10" x 2.5" 10" x 2.25"
 Cast Iron Center Polyolefin
 Moldon Rubber



150596150691

Manual Aluminum Drum Trucks

- Spring loaded chime hook automatically engages drum.
- Two wheel choices: 10" Moldon Rubber on Aluminum Hub or 12" Pneumatic Steel Hub.
- Disc wheel brake activated by hand lever:
 - B: with brake. NB: no brake.
- Steel, poly and fiber drums.
- 30 and 55 gallon drums.



OVERALL DIMENSIONS

w: 25.875"
h: 60"
d: 18.5"

- Two chime hooks available:
 - SCH:** standard hook for closed head steel, fiber and poly drums (**SC**). (Not for use on drums with locking ring or 85 gallon size.)
 - LCH:** special order hook for steel, fiber and poly drums with locking rings. Can be used on 85 gallon drums (**LC**).

LCH - Hook for Steel, Fiber, Poly Drums & 85 Gallon Drums

Part #	240124	240132	240120	240134	240133	240119	240135
Model #	ABT-10-SC-B	ABT-10-SC-NB	ABT-12-SC-B	ABT-12-SC-NB	ABT-10-LC-NB	ABT-12-LC-B	ABT-12-LC-NB
Capacity	1,000 lbs	1,000 lbs	1,000 lbs	700 lbs	1,000 lbs	1,000 lbs	700 lbs
Brake	Yes	No	Yes	No	No	Yes	No
Wheels	10" Moldon Rubber Rear 6" Moldon	10" Moldon Rubber Rear 6" Moldon	12" Pneumatic Rear 6" Moldon	12" Pneumatic Rear 6" Moldon	10" Moldon Rubber Rear 6" Moldon	12" Pneumatic Rear 6" Moldon	12" Pneumatic Rear 6" Moldon
Weight	60 lbs	60 lbs	60 lbs	60 lbs	60 lbs	60 lbs	60 lbs



US PATENT NO. 9,302,688



#240019 WITH (#240211), OPTIONAL 3RD WHEEL, 304 STAINLESS STEEL



#240017



#240017 WITH (#240210) OPTIONAL 3RD WHEEL



Knock Down (KD) Drum Trucks

- UPSable - KD and boxed.
- Six models: (4) Steel and (2) **304 Stainless** Construction.
- Handles 30, 55 and 85 gallon drums.
- Models to handle steel and poly drums.
- Requires minimal assembly.
- All parts removable and interchangeable.
- Each of the six models include handle, frame, base, kickstand, axle, toe or feet, wheels, chime hook or belt and hardware.
- Foot operated break-over assist bar provides extra leverage to tilt and balance load and allows truck to rest in tilt-back position.
- Stainless** models okay for wash down.

Optional 3rd Wheel:

- Ergonomic design, better maneuverability.
- Better load support.
- Helps reduce breakover effort.
- 5" x 2" swivel caster.
- Two Models: #240210 for steel trucks, 13 lbs. #240211 for **304 stainless** trucks, 14 lbs.

Part #	240016	240017	240052	240053	240019	240020
Model #	KD-STL-STL-PU	KD-STL-POLY-PU	KD-STL-STL-PO	KD-STL-POLY-PO	KD-SS-STL-PO	KD-SS-POLY-PO
Capacity	1,000 lbs	1,000 lbs	1,000 lbs	1,000 lbs	1,000 lbs	1,000 lbs
Wheel	10" x 2.5" Polyurethane	10" x 2.5" Polyurethane	10" Polyolefin	10" Polyolefin	10" Polyolefin	10" Polyolefin
Drum Type Handled	Steel	Poly	Steel	Poly	Steel	Poly
Toe/Foot (replaceable)	Milled Toe #240060	Formed Foot #240115	Milled Toe #240060	Formed Foot #240115	Stainless Milled Toe #051904	Stainless Foot #050362
Construction	Steel	Steel	Steel	Steel	304 Stainless	304 Stainless
Chime Hook	#240214 - steel	N/A	#240214 - steel	N/A	#050197- stainless	N/A
Belt	N/A	#240212 - steel ratchet assembly	N/A	#240212 - steel ratchet assembly	N/A	#240213 - stainless buckle
Weight	70 lbs	78 lbs	63 lbs	71 lbs	66 lbs	75 lbs

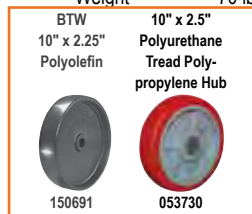



4-Wheel Drum Cart

■ Two position, 4-wheel transport design to handle drums and standard loads.

Position I: Easily handles and maneuvers standard loads as a 4-wheel transport.

Position II: With the chime hook engaged and a press of the foot pedal, the frame tilts a 30 or 55 gallon steel drum to a balanced position to maintain 4-wheel contact even with half empty bottom heavy drums.

- Two 3.5" x 1.5" polyolefin swivel casters for easy maneuverability in narrow spaces.
- Chime hook to engage 30 & 55 gallon steel drums.
- 7.8" D x 14" W beveled edge noseplate.
- Curved frame holds 5-gallon pails and kegs.

OVERALL DIMENSIONS

w: 19.25"	19.25"
h: 48"	48.5"
d: 26.25"	25"



156DH-Z

156DH-PP8-SS
304 STAINLESS STEEL

156DH Drum/Hand Truck

- Utility of a hand truck and drum truck.
- Chime hook works with 55 and 30-gallon steel drums.
- Curved frame holds 5-gallon pails and kegs.
- With noseplate resting flat on floor, 15.5" to center of lowered chime hook.
- Noseplate 7.8" D x 14" W.
- 304 stainless steel model #210352.
- Stainless model has 8" polyurethane, non-marking wheels with stainless precision ball bearings.

OVERALL DIMENSIONS

w: 20.5"	20.5"	20.5"	20.5"
h: 48"	48"	48"	48"
d: 18.5"	17.5"	18.5"	18.5"



304 STAINLESS STEEL

Series 626D-SS

- Stainless steel model 7.5" deep x 13.75" wide 7 gauge beveled nose plate with radiused corners for safety.
- Continuous frame loop.

OVERALL DIMENSIONS

w: 17.25"
h: 52"
d: 18"

Part #	210353	210354	210340	210349	210266	Stainless 210352	Stainless 210362
Model #	4WDC-ZC	4WDC-HBC	156DH-Z	156DH-HB	156DH-P	156DH-PP8-SS	626D-SS
Capacity	800 lbs	900 lbs	700 lbs	800 lbs	700 lbs	600 lbs	500 lbs
Wheels	10" / Z	8" / HB	Z	HB	P	8" Polyurethane	SR -10" Solid Rubber
Weight	66 lbs	66 lbs	39 lbs	42.5 lbs	39 lbs	33.5 lbs	24 lbs



Stainless Steel Drum Dollies

- **Wesco's Stability Advantage.** By design, Wesco casters are mounted past the dolly and drum rim. Our casters are mounted further apart than standard designs with casters completely underneath the drum and closer together. The further the casters are apart the greater the stability.
- Welded **304 stainless steel** dolly construction with reinforced outriggers.
- **304 stainless steel** dollies are ideal for clean room, pharmaceutical, food and wash down applications.
- Models available for 30, 55, and 85 gallon drums.

SS5-PPSS
All stainless rigs with
3" polypropylene
wheels



- Three caster set options:
 HRZ: zinc plated swivel rig with 3" hard rubber wheel & zinc plated hardware
 *HRSS: **304 stainless steel** swivel rig with 3" hard rubber wheel & stainless hardware
 *PPSS: **304 stainless steel** swivel rig with 3" white polypropylene wheel & stainless hardware.
 *Suitable for wash down applications.

CASTER MOUNTED BEYOND
DRUM AND DOLLY RIM FOR
GREATER STABILITY

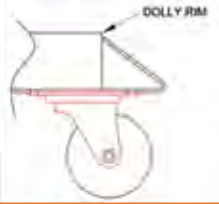

ASSEMBLED OVERALL
DIMENSIONS SS3

w: 24"
h: 6"
d: 24"

ASSEMBLED OVERALL
DIMENSIONS SS5

w: 28.5"
h: 6"
d: 28.5"

ASSEMBLED OVERALL
DIMENSIONS SS8

w: 31.5"
h: 6"
d: 31.5"

Part #	240192	240193	240194	240195	240196	240197	240198	240199	240200
Model #	SS3-HRZ	SS3-HRSS	SS3-PPSS	SS5-HRZ	SS5-HRSS	SS5-PPSS	SS8-HRZ	SS8-HRSS	SS8-PPSS
Capacity	900 lbs	900 lbs	1,000 lbs	900 lbs	900 lbs	1,000 lbs	900 lbs	900 lbs	1,000 lbs
I.D.	19"	19"	19"	24"	24"	24"	27"	27"	27"
Drum Size	30 gal	30 gal	30 gal	55 gal	55 gal	55 gal	85 gal	85 gal	85 gal
Caster Rig	Zinc plate 4 swivel	Stainless 4 swivel	Stainless 4 swivel	Zinc plate 4 swivel	Stainless 4 swivel	Stainless 4 swivel	Zinc plate 4 swivel	Stainless 4 swivel	Stainless 4 swivel
3" Caster Wheel	Hard Rubber	Hard Rubber	White Polypropylene	Hard Rubber	Hard Rubber	White Polypropylene	Hard Rubber	Hard Rubber	White Polypropylene
Dolly Material	304 Stainless	304 Stainless	304 Stainless	304 Stainless	304 Stainless	304 Stainless	304 Stainless	304 Stainless	304 Stainless
Weight	20 lbs	20 lbs	18 lbs	22 lbs	22 lbs	21 lbs	24 lbs	24 lbs	23 lbs

Steel Drum Dollies

- **Wesco's Stability Advantage.** By design, Wesco casters are mounted past the dolly and drum rim. Our casters are centered under the dolly rim and further apart than standard designs which are inside the rim and closer together. The further the casters are apart, the greater the stability.
- All welded steel frame construction with reinforced outriggers.
- Four bolt on 3" swivel casters.
- I.D. varies among models.
- Models available for 30, 55, and 85 gallon drums.



D5-SI



4 swivel casters.

CASTER MOUNTED BEYOND
DRUM AND DOLLY RIM FOR
GREATER STABILITY



ASSEMBLED OVERALL
DIMENSIONS - D3

w: 24"
h: 6"
d: 24"

ASSEMBLED OVERALL
DIMENSIONS - D5

w: 28.5"
h: 6"
d: 28.5"

ASSEMBLED OVERALL
DIMENSIONS - D8

w: 31.5"
h: 6"
d: 31.5"

Part #	240028	240029	240030	240031	240088	240089
Model #	D3-SI	D3-HR	D5-SI	D5-HR	D8-SI	D8-HR
Capacity	1,000 lbs	900 lbs	1,000 lbs	900 lbs	1,000 lbs	900 lbs
I.D.	19"	19"	24"	24"	27"	27"
Drum Size	30 gal	30 gal	55 gal	55 gal	85 gal	85 gal
Caster Rig	Zinc plate 4 swivel	Zinc plate 4 swivel	Zinc plate 4 swivel	Zinc plate 4 swivel	Zinc plate 4 swivel	Zinc plate 4 swivel
3" Caster Wheel	Sintered Iron	Hard Rubber	Sintered Iron	Hard Rubber	Sintered Iron	Hard Rubber
Dolly Material	Steel	Steel	Steel	Steel	Steel	Steel
Weight	18 lbs	18 lbs	24.5 lbs	22 lbs	26 lbs	26 lbs



Polypropylene Dolly

- 5 swivel casters, 3" polyolefin wheels.
- Handles 30 or 55 gallon drums.
- Rigid latticed understructure for strength.

OVERALL DIMENSIONS	
w:	24.25"
h:	7.125"
d:	24.25"



Specialty Dollies

- 3" hard rubber caster.
- Steel or aluminum designs.

OVERALL DIMENSIONS				
w:	24.5"	25.75"	24.5"	24.5"
h:	6"	6"	6"	6"
d:	24.5"	24.5"	24.5"	24.5"



PT Pail Truck

- Handles up to four standard steel or plastic 5-gallon pails.
- Ergonomic design eliminates the need to stack pails on a noseplate.
- 10" Semi-Pneumatic - **#150589**.

OVERALL DIMENSIONS	
w:	26"
h:	55"
d:	21"

Pail Tipper

- Adjustable chime hook.
- Ships KD easy assembly.
- Boxed dimensions 16.5"W x 22"D x 3"H.
- For dispensing 5 gal. steel or plastic pails.

OVERALL DIMENSIONS	
w:	14.5"
h:	30"
d:	14.5"

Part #	240201	240033	240040	240043	240044
Model #	P55-30-P	RSD	SSD*	RASD	RAOD
Capacity	900 lbs	900 lbs	900 lbs	900 lbs	900 lbs
I.D.	23.25"	24"	23.625" sq.	24"	24"
Drum Size	30 or 55 gal	55 gal	30 or 55 gal	30 or 55 gal	30 or 55 gal
Caster Rig	Zinc Plate 5 Swivel	Zinc plate 2 Rgd./2 Sw.	Zinc plate 4 swivel	Zinc plate 4 swivel	Zinc plate 4 swivel
3" Caster Wheel	Polyolefin	Hard Rubber	Hard Rubber	Hard Rubber	Hard Rubber
Dolly Material	Polypropylene	Steel	Steel	Aluminum	Aluminum
Weight	17 lbs	22 lbs	47 lbs	20 lbs	14 lbs

Part #	240042	273108
Model #	PT	PTR
Capacity	500 lbs	70 lbs
Brake	N/A	N/A
Wheels	Semi-Pneumatic	N/A
Weight	40 lbs	10 lbs



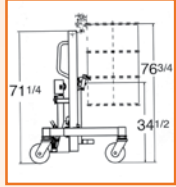
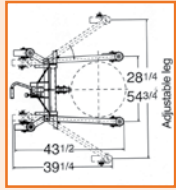

HLDT-880

High-Lift Hydraulic Drum Truck

- Handles 55, and 85 gallon drums.
- Easy width adjustment to accommodate a variety of pallets.
- Four 7½" moldon polyurethane swivel casters.
- Locking rear casters.
- Works with most rimmed steel and poly drums.
- Not for use with open head drums or drums with lid rings.

OVERALL DIMENSIONS

w: 54.75"
h: 71.25"
d: 43.5"

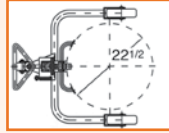
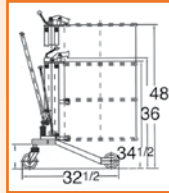
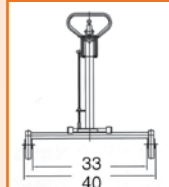

HDT-550

Economy Hydraulic Drum Truck

- Handles steel drums up to 22½" in diameter.
- 2 rigid and 1 swivel locking caster for easy maneuverability.
- Pallet truck-type pump handle.
- Works with most rimmed steel drums.

OVERALL DIMENSIONS

w: 40"
h: 46"
d: 32.5"



PTDL

Pallet Truck Drum Lifter

- Hydraulic pallet truck design to lift and move 55 gallon steel drums.
- Lowered height: 10"
- Raised height: 14.5"
- 8" x 2" nylon steering wheels.
- 1" x 3" nylon load wheels.

OVERALL DIMENSIONS

w: 28.5"
h: 47.5"
d: 42"



VDCD



Value Drum Carrier and Dispenser

- Economically priced.
- Three height adjustments: 9.25", 10.625" and 12".
- Vertical and horizontal locking positions.
- Polyurethane wheels and casters.
- 8" x 2" wheels and 4" x 1.25" caster.
- Ships KD.

OVERALL DIMENSIONS

w: 35"
h: 65.5"
d: 37"



500



Spill-Less Open Drum Truck

- Transport drums in a vertical position.
- Handles 55 gallon drums.
- 8" x 2" moldon rubber wheels with roller bearings.
- 5" x 2" polyolefin swivel casters.
- All welded construction.

OVERALL DIMENSIONS

w: 32"
h: 32.25"
d: 25.25"

Part #	272967	272945	273250	272404	240015
Model #	HLDT-880	HDT-550	PTDL	VDCD	500
Capacity	880 lbs	550 lbs	660 lbs	Full Drum - 800 lbs Half Drum - 500 lbs	1,000 lbs
Wheels	(4) 7.5" Polyurethane Swivel	(2) 8" Polyurethane Wheels (1) 5" Polyurethane Caster	(2) 8" x 2" Nylon Steering Wheels (2) 1" x 3" Nylon Load Wheels	(2) 8" x 2" Polyurethane Wheels (1) 4" x 1.25" Polyurethane Caster	(2) 8" x 2" Moldon Rubber w/ Roller Bearings (1) 5" x 2" Polyolefin Swivel Caster
Lift Height	76.75" to top of drum 42.5" to bottom of 34.5" steel drum	48" to top of drum 13.5" to bottom of 34.5" steel drum	N/A	N/A	N/A
Lift	0.45" per stroke	0.87" per stroke	N/A	N/A	N/A
Leg Span Adjustment	28.25" - 54.75"	N/A	N/A	N/A	N/A
Lift Range	42.5"	13.5"	N/A	N/A	N/A
Weight	220 lbs	99 lbs	115 lbs	105 lbs	70 lbs

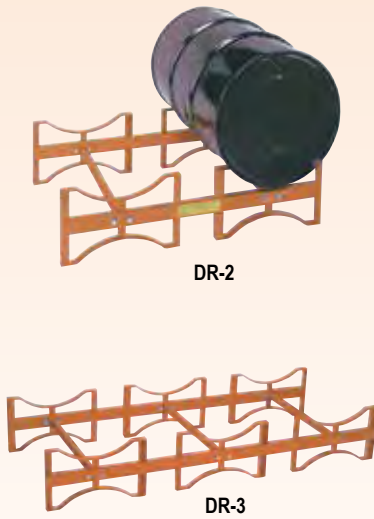

Drum Racks

- Two and three 55 gal. steel drum models.
- Four-side fork truck entry.
- Can be stacked 4 high.
- Standard models ship knocked down and boxed via UPS.
- Quick and easy to assemble.
- Welded and bolted construction.

OVERALL DIMENSIONS

w: 45.5"	71.5"
h: 12.5"	12.5"
d: 30"	30"



Deluxe Drum Cradle

- Superior Quality North American Hardwood Handles
- Tips, drains, stores, rotates and moves 30 or 55 gallon steel drums.
- Dual telescoping wood handles allow easy two handed control.
- Large 4" x 1.25" polyolefin wheels for easy movement over uneven floors.
- Shipped knocked down and boxed via UPS.
- **Backed by 2 year warranty against weld failure.**
- Drip tray option available.

OVERALL DIMENSIONS

w: 19"
d: 43" - 67.375"
h: 25.5"
20" drain height

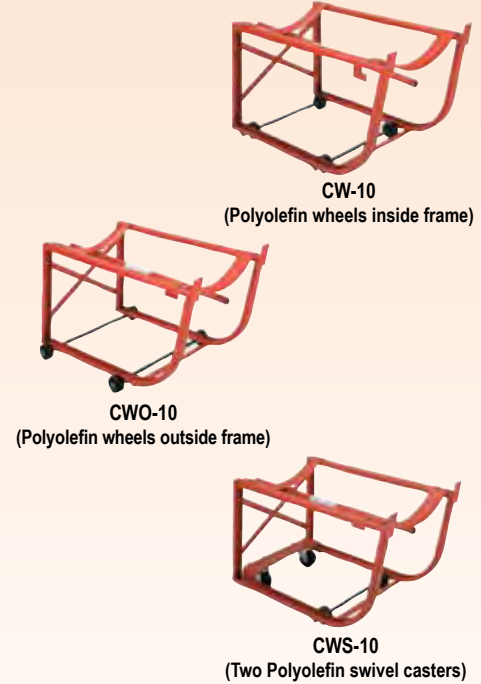

Standard Steel Drum Cradles

- Economical and convenient way to tip, drain and store 55 gallon steel drums.
- Easy for one person to use.
- All models ship knocked down and boxed via UPS.
- Models available with 2.5" polyolefin wheels, self-storing load tipping lever, and swivel casters.
- Drip tray option available for all models

OVERALL DIMENSIONS

w: 19.5"
d: 32.5"
h: 15" on wheeled models
13.5" on non-wheeled models

Part #	240026	240027	240025	240022	240023	240024
Model #	DR-2	DR-3	CW-20	CW-10	CWO-10	CWS-10
Capacity	1,600 lbs (2 drums)	2,400 lbs (3 drums)	1,000 lbs	600 lbs	600 lbs	600 lbs
Wheels	N/A	N/A	(4) 4" x 1.25" Polyolefin Wheels	(4) 2.5" Polyolefin Wheels	(4) 2.5" Polyolefin Wheels	2.5" Polyolefin: (2) Wheels (2) Casters
Weight	49 lbs	64.5 lbs	50 lbs	30 lbs	32 lbs	34 lbs

Drip Tray

- Steel slide-out tray 9.75" x 9.75" with 1.75" lip.
- Fits all Wesco drum cradles.
- Polyethylene pan.
- Cellulose absorbent holds 3 quarts of liquid.



CW-10 With Optional Drip Tray

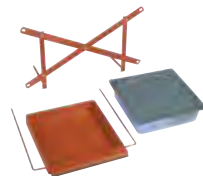

DT - Drip Tray Kit with Plastic Absorbent Pan

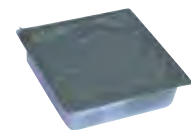

270414 - Replacement Plastic Absorbent Pan (Disposable)

Part #	270413	270414
Model #	DT	DP
Weight	7.5 lbs	1 lb



EDL-5



Economy Drum Lifter

- Lightweight and easy to use.
- Lock pin design holds drum firmly in place.
- Ships boxed via UPS.
- For use with closed head 55 gallon steel drums.

OVERALL DIMENSIONS

w: 23.5"
h: 12.5"
d: 25.5"



Open head steel



Closed head steel



Open head poly

Open Head Drum Lifters

- For use with standard steel or poly drums with at least a 3/16" chime.
- Lifting arms are a djustable to work with most 55 or 30 gallon drums.
- Three-point contact of the lifting arms prevents or minimizes deformation of the drum and provides more secure lifting.
- Also works on closed head drums.

OVERALL DIMENSIONS

w: 29.5"
h: 5.5"
d: 29.5"



NOW AVAILABLE IN 304 STAINLESS STEEL



UDL



Universal Drum Lifter

- Two models - UDL: carbon steel UDL-SS: 304 stainless steel.
- Design allows for theloading of drums into overpacks.
- Works on open and closed head drums.
- For use with standard steel or poly drums with at least a 3/16" chime.
- Lifting arms are adjustable to work with most 55 or 30 gallon drums.
- Three-point contact of the lifting arms prevents or minimizes deformation of the drum and provides more secure lifting.

OVERALL DIMENSIONS

w: 29.5" 29.5"
h: 5.5" 5.5"
d: 29.5 29.5

Stainless



SDL-85



SDL-55

Salvage Drum Lifters

- Convenient for fast and gentle loading of steel drums into overpacks.
- Ships boxed via UPS.
- For use with closed head steel drums.

OVERALL DIMENSIONS

w: 9.875" 9.875"
h: 7.375" 7.375"
d: 19.63" 19.63"



DRL-3

Hoist Mount Drum Lifter

- Heavy duty annealed ductile iron.
- Curved foot on stabilizing arm prevents damage to drum.

OVERALL DIMENSIONS

w: 24.5"
h: 17.5"
d: 2.25"



DLS Drum Sling 440009 (steel)

Drum Sling

- Horizontally lift all "closed or open-head" drums.
- D-shaped lifting ring fits most overhead systems.
- Inverted ring fits web-lifting slings.

OVERALL DIMENSIONS

w: 2.25"
h: 18.75"
d: 2"

Part #	240057	240038	240062	240063	240100	240102	440001	440009
Model #	EDL-5	OHDL-3	UDL	UDL-SS	SDL-55	SDL-85	DRL-3	DLS-1000
Capacity	700 lbs	1,000 lbs	1,000 lbs	1,000 lbs	1,000 lbs	1,000 lbs	3,000 lbs	1,000 lbs (Steel)
Weight	17 lbs	18 lbs	20 lbs	21 lbs	20 lbs	18 lbs	37 lbs	5 lbs



FIVE MODELS ALL WITH
U.S. PATENTED
GATOR GRIP®
U.S. PATENT NO. 6,619,905



Standard Model



Power Lift



High Reach Model



Scale Model - Accuracy $\pm 0.50\%$
of applied load or 1 lb.,
whichever is greater.



Power Lift & Drive



304 Stainless Steel
Drum Handler



STEEL



FIBER



POLY

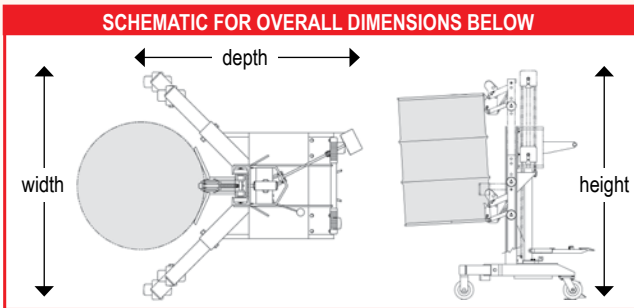

Wesco® Ergonomic Drum Handlers

- 1 Year Warranty, parts only.
- WESCO MADE hydraulic pump - all models.
- Handles most 30, 55 or 85 gallon drums - Steel, Fiber and Poly.
- Works with most drums with locking rings.
- Up/Down remote on power units.
- Power drive travel speed 120'/min.
- Lifts, transports, weighs and places drums on spill or standard pallets.
- (6) models: (5) steel and (1) 304 Stainless Steel.
- The (5) steel models are standard with the Gator Grip® Drum Clamp:
 - Spring-loaded jaws hold any 3/16" or higher drum rim.
 - Operator does not need to touch drums to operate.
 - Exclusive auto grip lock will not drop a drum if operated properly.
 - (2) wheels and (2) swivel casters, 5" x 2" phenolic, and floor lock.
- The 304 Stainless Steel SSDH model features:
 - Wesco manufactured 304 Stainless Steel construction hydraulic jack.
 - 304 Stainless Steel automatic Grab that grips drum rim and can be manually locked down for lift and travel.
 - (2) 5" x 2" black phenolic wheels with 304 Stainless Steel roller bearings.
 - (2) 304 Stainless Steel NSF certified washdown swivel casters with 5" x 2" black phenolic wheels, 304 Stainless Steel bearings.
 - Works with most drums with locking rings.
 - Lift range: 26" - 73" at lifting clamp.
 - Single position outriggers - non-telescoping.
 - 304 Stainless Steel construction includes hydraulic pump, floor lock, clamp, casters and bearings.
 - Handles most 30, 55 and 85 gallon steel, poly and fiber drums.

OVERALL DIMENSIONS

w: 41"	41"	42"	41"	41"	46"
h: 54"	73"	54"	73"	73"	73"
d: 39"	39"	43"	53"	53"	42"

Part #	240150	240154	240155	240156	240157	240240
Model #	DM-1100	DM-1100-HR	DM-1100-S	DM-1100-PL	DM-1100-PLD	SSDH
Description	Standard	High Reach	Scale	Power Lift	Power Lift & Drive	304 Stainless High Reach
Rise/Stroke	1"	1"	1"	8.5" / sec. without load	8.5" / sec. without load	1"
Legs Retracted Capacity	650 lbs	650 lbs	650 lbs	650 lbs	650 lbs	N/A
Legs Extended Capacity	1100 lbs	1100 lbs	1100 lbs	1100 lbs	1100 lbs	800 lbs
Drum Clamp Type	Gator Grip®	Gator Grip®	Gator Grip®	Gator Grip®	Gator Grip®	Auto Grab Manual Knob Lock Down
Weight	355.5 lbs	376 lbs	356 lbs	531 lbs	691 lbs	207 lbs



DM-800-MDT-Standard
Part# 240189



**Manual Drum Tilter w/
Removable Tilt Handle**



**Gear Drum Tilter w/
Crank Handle**



DM-800-MDT-High Reach
Part# 240128



DM-800-MDT-Power Models
Part# 240129 (Power Lift)
Part# 240130 (Power Lift & Drive shown)



DM-800-MDT-Power Models
Part# 240229 (Power Lift)
Part# 240230 (Power Lift & Drive shown)



DM-800-MDT-High Reach
Part# 240228

Manual Drum Tilter w/Handle

- Combines the heavy duty quality and reliability of the DM-1100 Ergonomic Drum Lifter and adds a new option to allow the drum handler to easily lift 55 gallon steel drums and dispense the contents.
- Locks in either a horizontal or vertical position for convenient dispensing or transport.
- 41" wheel clearance (spans standard skids)
- 17"-39" Lifting Range (center of drum)
- 1' lift per stroke (foot hydraulic models)
- Removable tilt handle
- Floor Lock standard on manual models only

OVERALL DIMENSIONS

w: 48"	48"	53"	53"
h: 61"	61"	73"	73"
d: 46.5"	46.5"	53"	53"

Gear Drum Tilter w/Crank

- This new option allows the Wesco DM-1100 to easily lift 55 gallon steel drums and dispense the contents using a crank handle.
- Crank handle lifts drums to dispensing height with 360° control.
- Handles fully-loaded drums up to 800 lbs.; half-full drums up to 500 lbs.
- 41" wheel clearance (spans standard skids)
- 17"-39" Lifting Range (center of drum)
- 1' lift per stroke (foot hydraulic models)
- 30:1 gear ratio
- 8 cranks per 90° rotation
- Floor Lock standard on manual models only

OVERALL DIMENSIONS

w: 48"	48"	48"	48"
h: 62"	77.75"	77.75"	77.75"
d: 52"	52"	52"	67"

Part #	240189	240128	240129	240130	240227	240228	240229	240230
Model #	DM-800-MDT	DM-800-MDT-HR	DM-800-MDT-PL	DM-800-MDT-PLD	DM-800-GDT	DM-800-GDT-HR	DM-800-GDT-PL	DM-800-GDT-PLD
Capacity Full Drum	800 lbs	800 lbs	800 lbs	800 lbs	800 lbs	800 lbs	800 lbs	800 lbs
Capacity Half Drum	500 lbs	500 lbs	500 lbs	500 lbs	500 lbs	500 lbs	500 lbs	500 lbs
Rise/Stroke	1"	1"	8.5" / sec. without load	8.5" / sec. without load	1"	1"	8.5" / sec. without load	8.5" / sec. without load
Weight	415 lbs	436 lbs	590 lbs	750 lbs	465 lbs	486 lbs	640 lbs	800 lbs



Option

- DMG-30A for use with 30 gallon drums, and FBA for use with fiber drums. For use with DL and DGL-55 models only.
- DGL-30-A Part #270040
- FBA Part #270402



Value Lifter
VDL-55

Value Drum Lifter/Dispenser

- Easily lift drum and dispense contents.
- Economical, lower capacity VALUE product.
- Ships assembled and boxed.
- Locks in horizontal or vertical position.
- Handles 55 gallon steel drums.

OVERALL DIMENSIONS

w: 8.5"
h: 36"
d: 29"



DL-55

Standard Drum Lifter/Dispenser

- Higher capacity quality product.
- Ships assembled and boxed.
- Easily lift drum and dispense contents.
- Locks in horizontal or vertical position.
- Handles 55 gallon steel drums.
- Over 25 years of proven reliable quality.

OVERALL DIMENSIONS

w: 8.5"
h: 36"
d: 29"

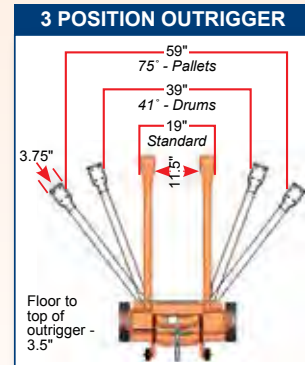

Triple Truck/
Drum Attachment

PATENT NO.
US9,139,214B2

- Purchase as two parts. **FOR COMPLETE DETAILS, SEE PAGE 62 OF MASTER CATALOG.**
- Adjustable outriggers from 11.5" I.D. to 59" I.D.

Part #	278750	240032	261160 & 261161
Model #	VDL-55	DL-55	TTF+TTF-GG
Capacity			750 lbs. Per Grip
Full Drum	700 lbs	800 lbs	
Half Drum	440 lbs	500 lbs	
Weight	54 lbs	45 lbs	#261160 / 357 lbs #261161 / 32 lbs



Gator Grip®

US PATENT NO. 6,619,905

Traditional devices require drum weight to maintain a positive lock. If a drum bounces during fork truck transportation, the drum may momentarily become weightless, which can cause the grip to snap open dropping the drum. The patented Auto Grip Lock automatically locks the jaws closed, even over rough terrain.

STEEL



FIBER



POLY



The Wesco Gator Grip Fork Truck Mounted Drum Grab is designed for lifting and transporting 16, 30, 55 and 85 gallon steel, fiber and poly drums.



EGG-1



Fork Truck Carriage Mount - GG-C



Single Drum Fork Mount - GG-F1



Power Stacker Mount - GGPS



EGG-2

- Fork truck fork attachment.
- Picks up drums automatically, driver never leaves seat while lifting or releasing drums.
- Handles steel, fiber and poly drums.
- Single and dual grips available.
- Gator Grips® made by Wesco.
- Economically priced.
- Patented Gator Grip®.



Dual Drum Fork Mount - GG-F2

- Heavy-duty carriage design.
- Single and dual grips available.
- Fork truck attachment.
- Patented Gator Grip®.



Gator Belt Option - GGBK

- Optional Gator Belt protects drum from wear. **NOT AVAILABLE ON EGG MODELS.**

OVERALL DIMENSIONS

	240091	240092	240093	240096	240097	240103	240107
w: 28"	33.25"	15.625"	32"	32"	18"	30"	
h: 34"	34"	33.25"	37"	37"	33.25"	3"	
d: 34"	34"	18"	28"	28"	17"	25"	

Part #	240091	240092	240093	240096	240097	240103	240107
Model #	EGG-1	EGG-2	GG-C	GG-F1	GG-F2	GGPS	GGBK
Capacity Per Grip	1,000 lbs	1,000 lbs	1,600 lbs	1,600 lbs	1,600 lbs	1,600 lbs	N/A
Fork Pocket ID	5.5" x 2"	7" x 2.25"	N/A	7" x 2.25"	7" x 2.25"	N/A	N/A
Weight	125.5 lbs	208 lbs	96 lbs	244 lbs	340 lbs	92 lbs	4 lbs

Note: OSHA requires contacting the manufacturer of your fork truck for written approval for the use of any fork truck attachments.

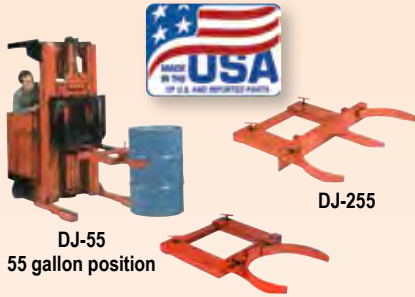

DJ-55
55 gallon position

DJ-255

Drum Grabs for 55 Gallon Steel Drums

- All welded steel construction for durability.
- Cost effective way to move 55 gallon steel drums.

OVERALL DIMENSIONS

w:	28"	28"	46"
h:	4.75"	4.75"	7.25"
d:	42.75"	42.75"	43.25"



ADJ-53
30 gallon position

Adjustable Drum Grabs for 55 or 30 Gallon Steel Drums

- ADJ models feature all welded steel construction for durability.
- Handles 55 or 30 gallon steel drums.

OVERALL DIMENSIONS

w:	28"	28"
h:	5.5"	5.5"
d:	41.75"	41.75"



SAVG-53

DVG-255

DAVG-253

Value Drum Grabs

- Economically priced lower capacity grabs.
- VG models: jaws not adjustable. Handles 55 gal. steel drums.
- AVG models: adjustable jaws. Handles 30 or 55 gal. steel drums.

OVERALL DIMENSIONS

w:	46"	28"	51"
h:	7.25"	5.5"	7.25"
d:	43.25"	41.75"	42.75"

Part #	240048	270051	240049	240047	270084	272401	272408	272409
Model #	DJ-55	DJL-55	DJ-255	ADJ-53	ADJL-53	DVG-255	SAVG-53	DAVG-253
Capacity	1,500 lbs/drum	1,500 lbs/drum	1,500 lbs/drum	1,500 lbs/drum	1,500 lbs/drum	1,000 lbs/drum	1,000 lbs/drum	1,000 lbs/drum
Handles	one 55-gallon	one 55-gallon	two 55-gallon	one 55 or one 30 gallon	one 55 or one 30 gallon	two 55-gallon	one 55 or one 30 gallon	two 55 or two 30 gallon
ID Fork Pocket	5.5" x 2"	7" x 2.25"	7" x 2.25"	5.5" x 2"	7" x 2.25"	7" x 2.25"	5.5" x 2"	7" x 2.25"
Weight	145 lbs	150 lbs	205 lbs	135 lbs	140 lbs	233 lbs	128 lbs	194 lbs

POWER DRUM ROTATOR



See page 65 of Master Catalog.



270402



240148

Model PJ for most 30 and 55 gallon drums



VFDLT-1400

Fork Truck Drum Lifter & Tilter DGF-55

- Fork truck driver does not have to leave truck to dispense.
- Geared design allows controlled dumping and dispensing.
- Does not require any modifications to the fork truck.
- Ships assembled and boxed.
- Has 800 lbs capacity for a full drum, 500 lbs for a half full drum.
- Not for use with poly drums.
- Fork pocket dimensions (ID) 6.625"W x 2.625"H.
- Fork pocket dimensions center to center 31".
- Length of Chain 144".

OVERALL DIMENSIONS

w:	38"
h:	20.5"
d:	32.5"

Wesco Polyjaws

- Fork truck adjustable attachment for handling most 55 and 30 gallon poly drums.
- Fork truck driver does not have to leave cab to engage or disengage drum.
- Works on poly drums that have at least a 3/16" top lip (chime).
- Substantially lower priced than any other poly drum lifter on the market.
- Ships knocked down/ boxed via UPS.
- Fork pocket dimensions (ID) 5.375"W x 1.5"H.

OVERALL DIMENSIONS

w:	25.5" -29.375"
h:	6.28"
d:	21.38"

Value Fork Truck Drum Lifter & Tilter

- Economically priced lower capacity model.
- Two models, 700 & 1,400 lb capacities.
- Operator does not have to leave seat to tilt drum.
- Fork pocket dimensions (ID) 7" W x 2.5"H.
- Fork pocket dimensions center to center 31.5".
- Length of Chain 120".

OVERALL DIMENSIONS

w:	39"	39"
h:	19"	19"
d:	26.75"	31.5"

Part #	240039	270240	270402	240148	272402	272403
Model #	DGF-55	DGF-30A	FBA	PJ	VFDLT-700	VFDLT-1400
	55 GAL. DRUM UNIT	30 GAL. DRUM ADAPTER	FIBER DRUM ADAPTER			
Capacity	Half Drum - 500 lbs Full Drum - 800 lbs	Half Drum - 500 lbs Full Drum - 800 lbs	Half Drum - 500 lbs Full Drum - 800 lbs	1,000 lbs	Half Drum - 440 lbs Full Drum - 700 lbs	Half Drum - 750 lbs Full Drum - 1,400 lbs
Weight	159 lbs	24 lbs	3 lbs	44 lbs	166 lbs	214 lbs

Note: OSHA requires contacting the manufacturer of your fork truck for written approval for the use of any fork truck attachments.

Zinc Die Cast Faucets

- Zinc die cast alloy.
- Easy-to-use self-closing design.
- Can be padlocked in closed position.
- .75" NPT connection.
- Viton gasket.



Part# 272083 - .53 lbs.
 With flame arrestor.
FM APPROVED for non-viscous liquids.



Part# 272080 - .53 lbs.
 No flame arrestor.
FM APPROVED for viscous liquids only.

Heavy Duty 2" Brass Gate Valve

- Fast, self-closing PTFE blade.
- 2" NPSM connection designed to work in both a straight or tapered thread.
- 6.80 lbs.



Part# 272034
FM APPROVED for use with viscous non-corrosive fluids heavier than 30 SAE.

Heavy Duty 304 Stainless Steel Faucet

- Adjustable shank designed to easily adjust to proper drain position after installing in drum.
- .75" NPT connection.
- PTFE gasket.
- 1.50 lbs.



Part# 272038
 Internal flame arrestor.
FM APPROVED for use with oils (under 30 SAE) and non flammables, compatible with stainless steel.

Heavy Duty Brass Faucets

- Easy-to-use self-closing design.
- .75" NPT connection.
- PTFE gasket.



Part# 272037 - 1.40 lbs.
 Adjustable shank designed to easily adjust to proper drain position after installing in drum.
 Internal flame arrestor.
FM APPROVED for use with oils (under 30 SAE) and non-corrosive flammables.



Part# 272081 - 1.43 lbs.
 Rigid shank design.
 External flame arrestor.
FM APPROVED for use with oils (under 30 SAE) and non-corrosive flammables.

Plastic Faucets

- 2" NPT polyethylene drum faucet produced from **FDA approved material**. Includes 3 EPDM sealing gaskets: thin, medium, thick. Good for viscous non-corrosive fluids.
- .83 lbs.



Part# 272176 - 2"

- Deluxe 2" NPT polyethylene drum faucet. Produced from **FDA approved material**.

- Deluxe features:
- Level gauge port
 - Pail hook
 - Lockable handle
 - 3 EPDM gaskets: thin, medium, thick.

- 1 lb.



Part# 272179 with level gauge



Part# 272179 - 2"

- .75" Polyethylene Faucet for use with non-flammable, non-corrosive thin liquids not suitable for heavy oils.

- .10 lbs.



Part# 272177 - .75"

Wesco recommends that if a question arises, the user contact the supplier of chemicals to determine if these faucets are compatible with those chemicals. Wesco is unable to offer specific recommendations for chemical usage.

Drum Vent

- Automatically relieves pressure at 5 PSI.
- Maximum flow of 220 CFM at 20 PSI.
- Flame arrestor prevents sparks and flame from igniting drum contents.
- Fits 2" bung hole in steel and plastic drums.
- 1 lb.



Part# 272030
 For drums in horizontal (pouring) position. Manual vacuum relief by lifting and rotating valve stem.
FM APPROVED.

Gauges

- Economical way to gauge drum contents.
- Heavy gauge glass and plated steel construction.
- Accepts standard .75" NPT faucet.
- Buna-N seals; .75" NPT connection, 22" height (with supplied fitting).



Part# 272005 - 2.16 lbs.
 Basic gauge with fitting.



Part# 272006 - 4 lbs.
 Basic gauge with fitting and 272080 faucet.

Part# 272041 - 5 lbs.
 Basic gauge with fitting and 272083 faucet.

Part# 272115 -
 Replacement glass for gauge.

Drum Funnel with Lockable Cover

- Red polyethylene 4-quart funnel with 2" NPS fitting to screw into bung opening.
- 9.625" opening.
- Equipped with black polyethylene lockable cover and removable strainer screen.
- 1.1 lbs.



Part #272140 Model #DF



Vertical Polyethylene Pop-up Gauge

- Pops up to indicate drum is almost full.
- Fits standard 3/4" - 14 NPS bung holes.
- Part #272216, Model # PUG-5 - 5" long.
- Part #272217, Model # PUG-11 - 11" long.
- Closure cap.



Ground and Bond Wires

- A wide variety of designs for grounding and bonding applications.

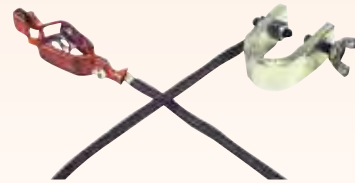

Part# 272032 - .64 lbs
 Deluxe Ground Wire: For connection between drum and true ground. Three-foot-long heavy duty insulated wire rope with "C" clamp on one end and alligator clip on the other.



Part# 272031 - .53 lbs
 All Purpose Bond Wire: For bonding drums to each other, to containers being filled, and to racks. Three-foot-long heavy duty wire rope with "C" clamp on one end and alligator clip on the other.



Part# 272033 - .37 lbs
 Standard Bond Wire: For bonding drums to each other, to containers being filled, and to racks. Three-foot-long heavy duty wire rope with alligator clips on both ends.

OSHA requires that all drums and containers storing and receiving fluids with a FLASH POINT BELOW 140°F be grounded and bonded. Single drums must be grounded, with containers being dispensed into bonded to the drum. Multiple drums must be bonded to each other with one drum or the rack grounded. Wesco Ground and Bond wires allow meeting these important safety requirements.

Deheaders

- Open any size and gauge steel drum quickly and easily, allowing drum recycling without the risk of fire from cutting with a torch.
- Sharp-edged hardened steel replaceable blade.
- Comfortable plastic hand grip.



Part# 272303
Vertical slide deheader. (6.2 lbs.)
Part# 272304 Replacement blade. (1 lb.)



Part# 272018
Most popular deheader. (7 lbs.)

Part# 272012
Replacement blade. (.73 lbs.)



Part# 440013 Model DDH-1.
Heavy duty deheader. (9 lbs.)

Part# 440014 Model DDH-P202
Replacement blade. (.60 lbs.)

Non-Sparking Deheader

- 100% non-sparking deheader.
- Sharp-edged hardened non ferrous alloy replaceable blade.
- Comfortable plastic hand grip.



Part# 272301
Non-sparking deheader.
100% non-sparking. (8 lbs.)

Part# 272302
Replacement blade. (.35 lbs.)

Universal Drum Plug Wrench

- Heavy duty cast iron construction.
- Opens most plugs and bung nuts, male & female, steel & plastic.
- Iron alloy will not chip or bend in normal use.
- Protects knuckles.



Part# 272017
(4 lbs.)
Handles bung patterns
1, 2, 3, & 4.

Bung Patterns

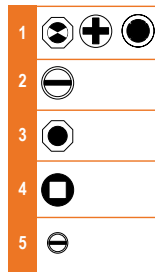

Non-Sparking Drum Plug Wrenches

- Bronze alloy.
- Stronger than aluminum.
- Offset handle design reduces user stress and minimizes knuckle injury.



Part# 272016
(2 lbs.)
Our most popular wrench.
Handles bung patterns
1, 2, 3, & 5.



Part# 272178
(.53 lbs.)
Aluminum
Non-Sparking
Drum Wrench.
Handles bung patterns
1 & 3.



Part# 272086
(3 lbs.)
Deluxe model. Built-in 1.25" wrench
for tightening faucets into
drums. Handles bung patterns
1, 2, 3, & 5.

Part #	Description	Weight - lbs	Overall Width	Overall Height	Overall Length
272303	Vertical slide deheader	6.20	5.75"	5.875"	17.75"
272304	Replacement blade for Part# 272303	1.00	2.75"	2.75"	.1875" (THK)
272018	Manual drum deheader	7.00	6"	4.25"	20.68"
272012	Replacement blade for Part# 272018 deheader	.73	2.75"	2.50"	.1875" (THK)
440013	Zinc plated heavy duty deheader	9.00	6.375"	4.625"	23.625"
440014	Replacement blade for Part# 440013 deheader	.60	3.1875"	2.875"	.1875" (THK)
272301	Non-sparking deheader	8.00	6.625"	4.875"	19"
272302	Replacement blade for Part# 272301 deheader	.35	2.875"	2.375"	.1875" (THK)
272017	Universal cast iron drum wrench	4.00	3.625"	3.50"	13.125"
272016	Standard non-sparking drum wrench	2.00	2.50"	3.25"	12"
272178	Non-sparking aluminum wrench	.53	2.25"	1.75"	10.25"
272086	Deluxe non-sparking drum wrench	3.00	3.625"	3.125"	11.50"

Application Information (For Rotary and Lever Pumps): WESCO iron drum pumps have wetted parts fabricated from cast iron, steel, phenolic (270021 & 272212 only), and neoprene (272210 only) materials. These pumps were designed primarily for the transfer of fuel oil products. It should be noted that these pumps can only be used for chemicals which are compatible with cast iron, steel, neoprene and phenolic.

We recommend that if a question arises, the user contact the supplier of chemicals to determine if these pumps are compatible with those chemicals. WESCO is unable to offer specific recommendations for chemical usage.

Rotary Pump

- 47" 3 piece plated suction tube (assembled).
- Durable phenolic veins.
- Self-priming.
- Supplied with 48" PVC discharge tube.
- UPS shippable.
- Rugged cast iron construction.
- ALWAYS USE A GROUND WIRE.



Part# 272212
Deluxe Combo (consists of #270021 Rotary Pump and #272211 Drip Pan) (18 lbs.)

Part# 270021
Cast Iron Rotary Drum Pump ONLY (12.5 lbs.)

Non-Sparking Rotary Pump

- Rugged aluminum construction.
- 47" 3 piece steel-plated suction tube (assembled).
- Durable phenolic veins.
- Self-priming.
- Supplied with 48" PVC discharge tube.
- UPS shippable.
- ALWAYS USE A GROUND WIRE.



Aluminum Pump only.

Part# 440017
Aluminum, non-sparking for medium viscosity petroleum-based products. Does not include drip pan. (17 lbs.)



Part# 272210
(18 lbs.)

Lever Pump/ Drip Pan

- For installation on pumps with metal suction tube.
- Cast iron and steel construction.
- Hinged cover and bung/suction adapter.
- UPS shippable.
- ALWAYS USE A GROUND WIRE.



Part# 272211
Drip pan. (6 lbs.)



Part# 272397
(13 lbs.)

304 Stainless Steel Rotary Pump

- Made from corrosion resistant materials of construction.
- **304 stainless steel** pump body.
- **304 stainless steel** dispensing spout.
- **304 stainless steel** 3 piece suction tube.
- PTFE vanes.
- UPS shippable.
- Compatible fluids: solvents, oils, mild corrosives.
- Min./ Max. temperature rating: 40° Fahrenheit / 140° Fahrenheit.
- 2" NPT Bung Adapter fits 15, 30 and 55 gallon drums.
- ALWAYS USE A GROUND WIRE.

Part #	Description	Weight - lbs	Overall Width	Overall Height	Overall Length
270021	Cast iron pump	12.50	9.4375"	56.25"	8.75"
272212	Deluxe combo with drip pan	18.00	9.4375"	56.25"	14"
440017	Non-sparking rotary pump	17.00	9.4375"	56.25"	9.50"
272210	Lever pump with drip pan	18.00	15.875"	60.343"	14"
272211	Drip pan	6.00	6.3125"	6.00"	14"
272397	304 stainless steel rotary pump	13.00	9.125"	53.125"	8.75"