

ITEM NO.	PART NUMBER	DESCRIPTION	QTY.
1	RP-42WS-BASE	Base	1
2	RP-42WS-AS	Angle	1

REVISIONS				
ZONE	REV.	DESCRIPTION	DATE	APPROVED
	B	Changed angle	3/8/2021	EGS

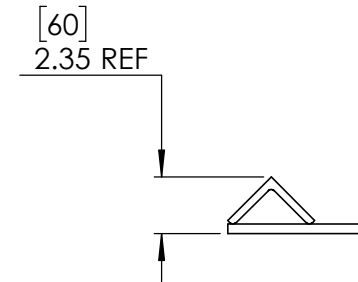
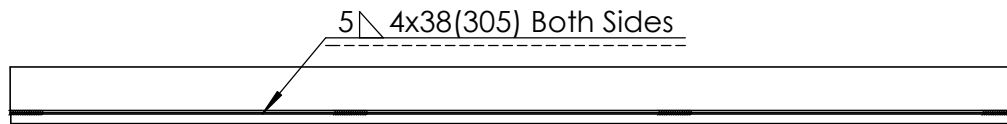
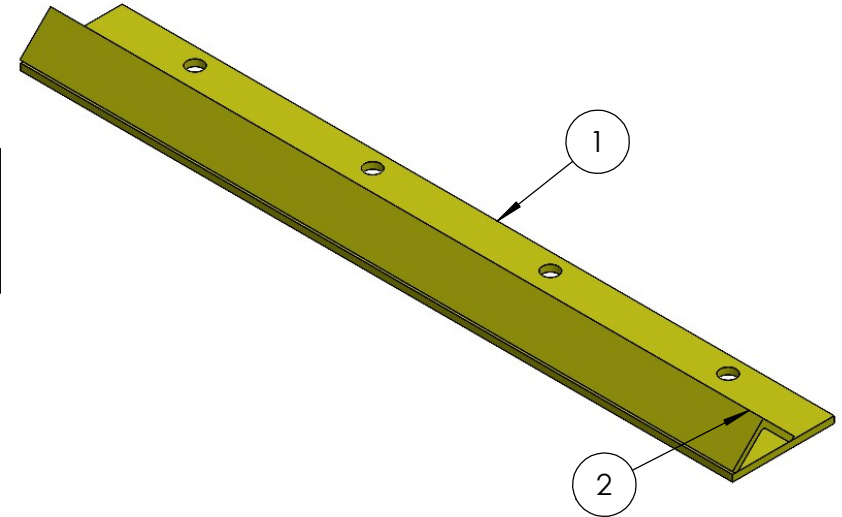
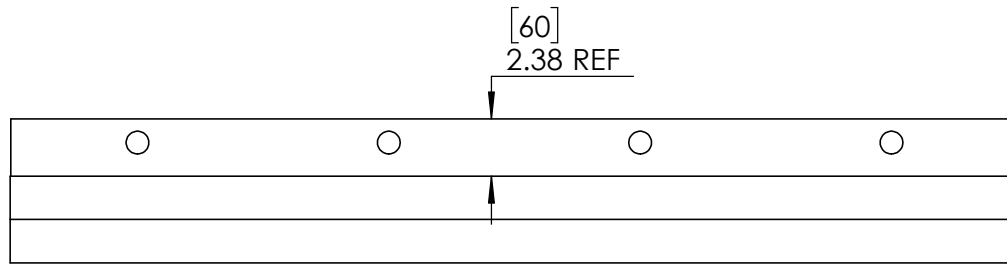

UNLESS OTHERWISE SPECIFIED: DIMENSIONS ARE IN INCHES [DIMENSIONS] ARE IN MM TOLERANCES: .X ± .12" [3 mm] .XX ± .06" [1.5 mm] .XXX ± .03" [0.7 mm] Angular ± 1°	NAME	DATE	<b>HANDLE-IT</b> <sup>®</sup> TITLE: Wheel Stop
	DRAWN	EGS 1/29/2021	
	CHECKED		
	ENG APPR.		
INTERPRET GEOMETRIC TOLERANCING PER:	Q.A.		SIZE DWG. NO. REV
MATERIAL Mild Steel	COMMENTS: See Notes		<b>A</b> RP-42WS-HD <b>B</b>
FINISH Yellow Powder Coat			SCALE: NTS WEIGHT: 45.7 LBS SHEET 1 OF 3
DO NOT SCALE DRAWING			

5

4

3

2

1

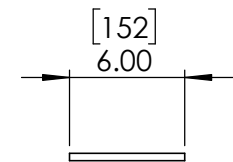
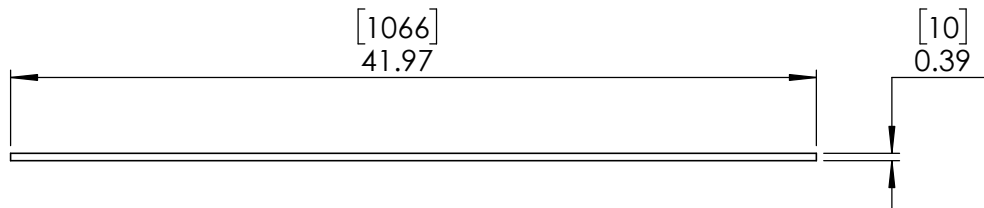
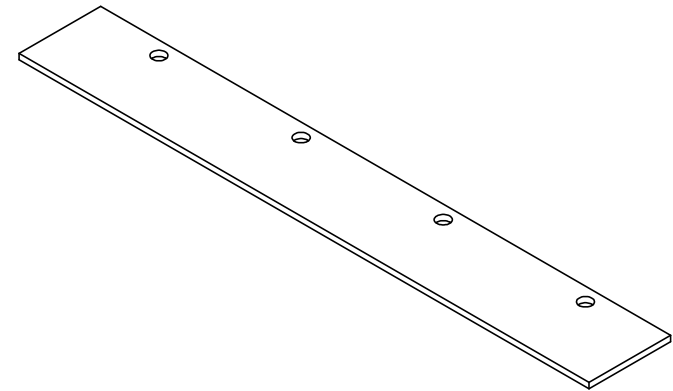
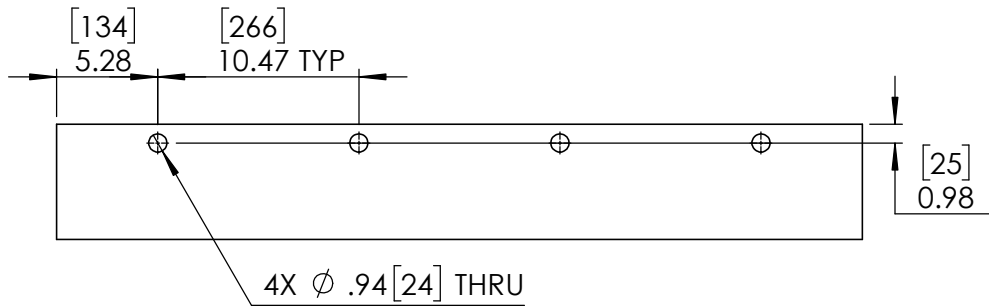

UNLESS OTHERWISE SPECIFIED:	NAME	DATE	
DIMENSIONS ARE IN INCHES [DIMENSIONS] ARE IN MM TOLERANCES:	DRAWN	EGS 1/29/2021	
.X ± .12" [3 mm]	CHECKED		TITLE:
.XX ± .06" [1.5 mm]	ENG APPR.		Base
.XXX ± .03" [0.7 mm]	MFG APPR.		
Angular ± 1°	Q.A.		
INTERPRET GEOMETRIC TOLERANCING PER:	COMMENTS:		
MATERIAL	See Notes		SIZE
Mild Steel		DWG. NO.	RP-42WS-BASE
FINISH		REV	A
Yellow Powder Coat			SCALE: NTS
DO NOT SCALE DRAWING			WEIGHT: 27.8 LBS
			SHEET 2 OF 3

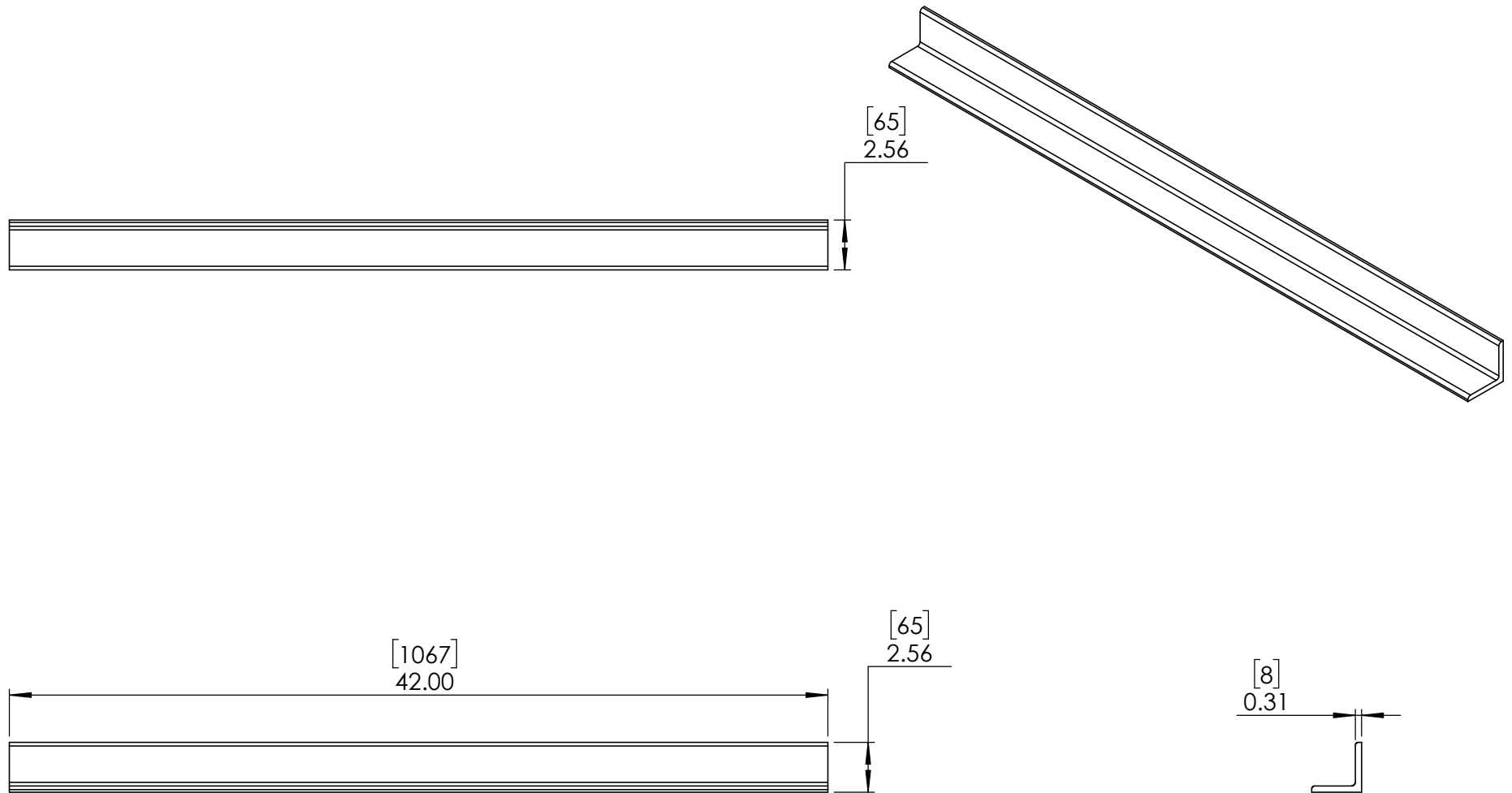

UNLESS OTHERWISE SPECIFIED:	NAME	DATE	
DIMENSIONS ARE IN INCHES [DIMENSIONS] ARE IN MM TOLERANCES:	DRAWN	EGS 1/29/2021	
.X ± .12" [3 mm]	CHECKED		TITLE:
.XX ± .06" [1.5 mm]	ENG APPR.		Angle
.XXX ± .03" [0.7 mm]	MFG APPR.		
Angular ± 1°	Q.A.		
INTERPRET GEOMETRIC TOLERANCING PER:	COMMENTS:		
MATERIAL	See Notes		SIZE DWG. NO. REV
Mild Steel			<b>A</b> RP-42WS-AS <b>B</b>
FINISH			
Yellow Powder Coat			SCALE: NTS WEIGHT: 17.9 LBS SHEET 3 OF 3
DO NOT SCALE DRAWING			