

# ProGenic Heavy Duty Pallet

SKU: PRG601-037

## Standard Features:

- Hygienic, flow through design
- One-Piece
- Easy to inspect
- Non-Halogen, FM Approved, FDA Compliant
- 4-way entry for forklift and pallet jacks
- Edge-Rackable up to 2,200 lbs.
- Ideal for food, pharmaceutical and washing applications
- Available in 3-Stringer model
- Hotstamp or Molded-in logo
- Bar code and RFID capable
- Optional interrupted perimeter lip keeps product from shifting during transit



Edge  
Rackable

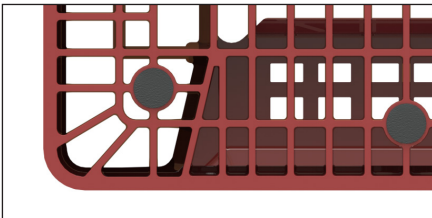

Grommets optional

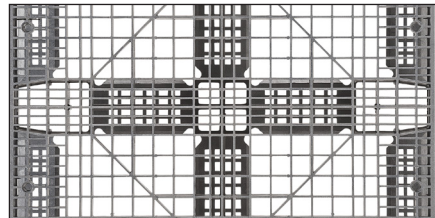

Hygienic flow through design



6-inch HD / 5-inch SD models



**SOURCE4**  
INDUSTRIES

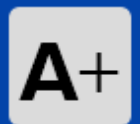

(866) 734-8848



sales@source4industries.com



source4industries.com



4436 Lawrence St  
Las Vegas, NV 89081

# ProGenic Series GMA+ Pallet

SKU: PRG601-037

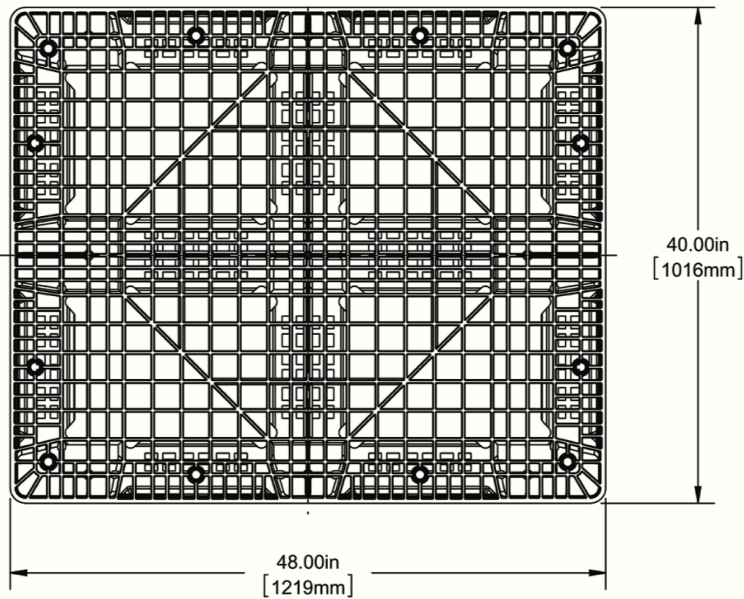

TOP VIEW

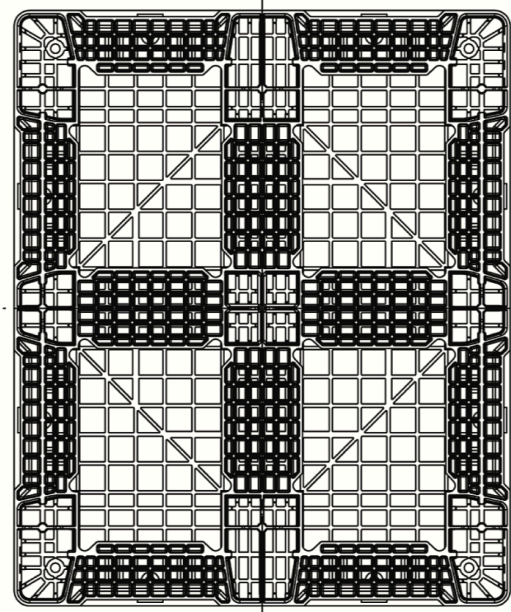

BOTTOM VIEW

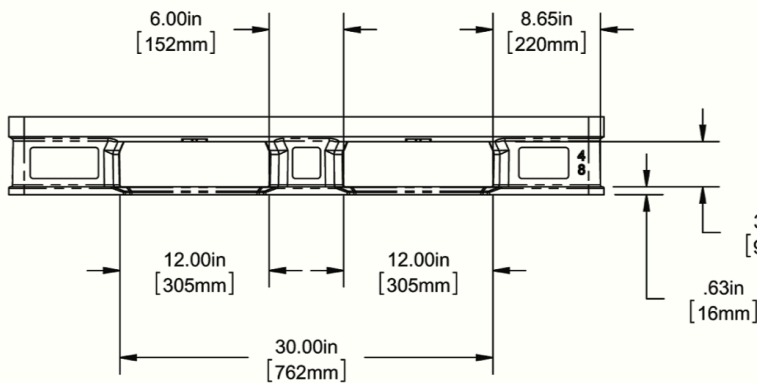

SIDE VIEW - 48"

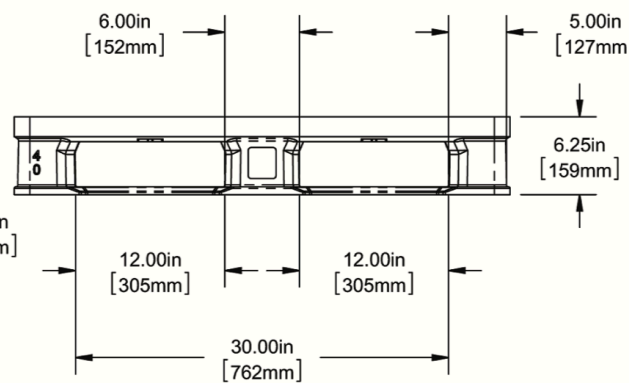

SIDE VIEW - 40"

## 40" X 48" ProGenic HD Pallet

DIMENSIONS				LOAD RATINGS (lbs.)				TRUCKLOAD CAPACITY	OCEAN CONTAINERS
Width	Length	Height	Weight	Static	Dynamic	Selected Edge Racking	Supported Racking	53'	40' HC
40 in.	48 in.	6.25 in.	45 lbs.	20,000	5,000	2,200 Unitized load at 72°F	5,000	QTY 510	QTY 340

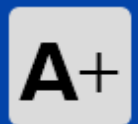

(866) 734-8848



sales@source4industries.com



source4industries.com



4436 Lawrence St  
Las Vegas, NV 89081