

PG-4840-N-107US

48x40 (Standard) Plastic Industrial Pallet



Technical Data

Dimensions 48x40x5.1 inches
Weight 11.5 lbs

Load Capacities

Static 3300 lbs
Dynamic 2100 lbs
Racking --

Entry 4-way
Truckload Qty 2370
Stack TL 79

TL (truckload) quantities are approximate and may vary by transport equipment or other factors.

Handling Data

Nestable Yes	Reusability One-Way & Multi-Trip	ISPM-15 Exempt Yes
Stackable No	Destination Export & Captive	Food Grade Yes, non-FDA
Rackable No	Airfreight Yes	Pharmaceutical Yes

Materials and Colors

Condition
New

Material HDPE/PP (Recycled) **Color** Black

(High-Density Polyethylene/Polypropylene)

Deck Specs

Top Deck
Open

Bottom Deck
9 Feet - Nesting

Available Options:

Closed Top Deck
3-Runner Bottom Deck (for stacking unit loads)
No perimeter lip = PG-4840-N-107USNL

Features

- Available in food-grade FDA material
- Safety Rim
- Designed to easily secure wrapping
- Nesting saves storage & shipping costs
- Easy-to-clean hygienic design
- Suitable for packaged food items
(not approved for direct food contact)
- Impervious to acids, fats, solvents and odors
- Resists water absorption & bacteria growth
- Inert to infestation, mold and mildew
- Consistently dimensionally accurate
- Exempt from ISPM 15 shipping regulations



Spec Sheet Generated On: 3/22/2023
Specs subject to change without notice. Provided for informational purposes only. Technical data are guideline values and may vary based on intended use, features, raw materials and environment. Nothing shall be construed as warranties or guarantees, express or implied, regarding products or their use, application, performance or otherwise.

Nelson™

The Nelson Company
(443) 649-5294

plastic@NelsonCompany.com
www.NelsonCompany.com
www.NelsonTechCenter.com

PG-4840-N-107US

48x40 (Standard)
Plastic Industrial Pallet



Technical Drawings

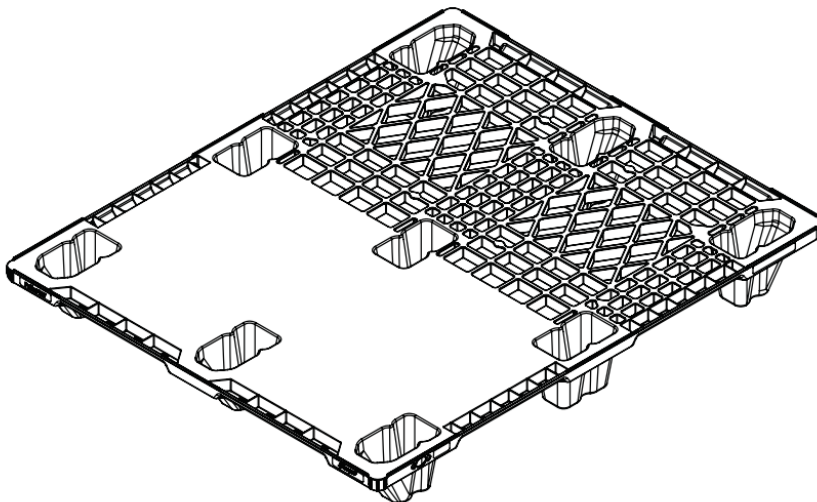
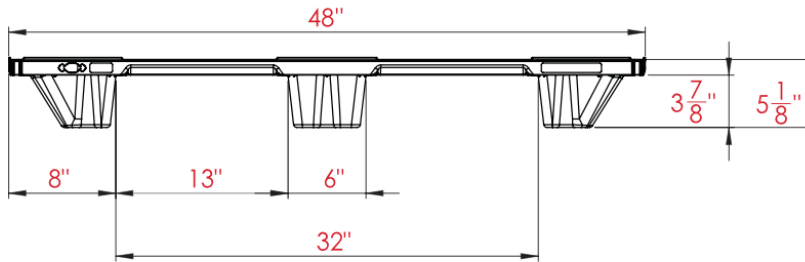
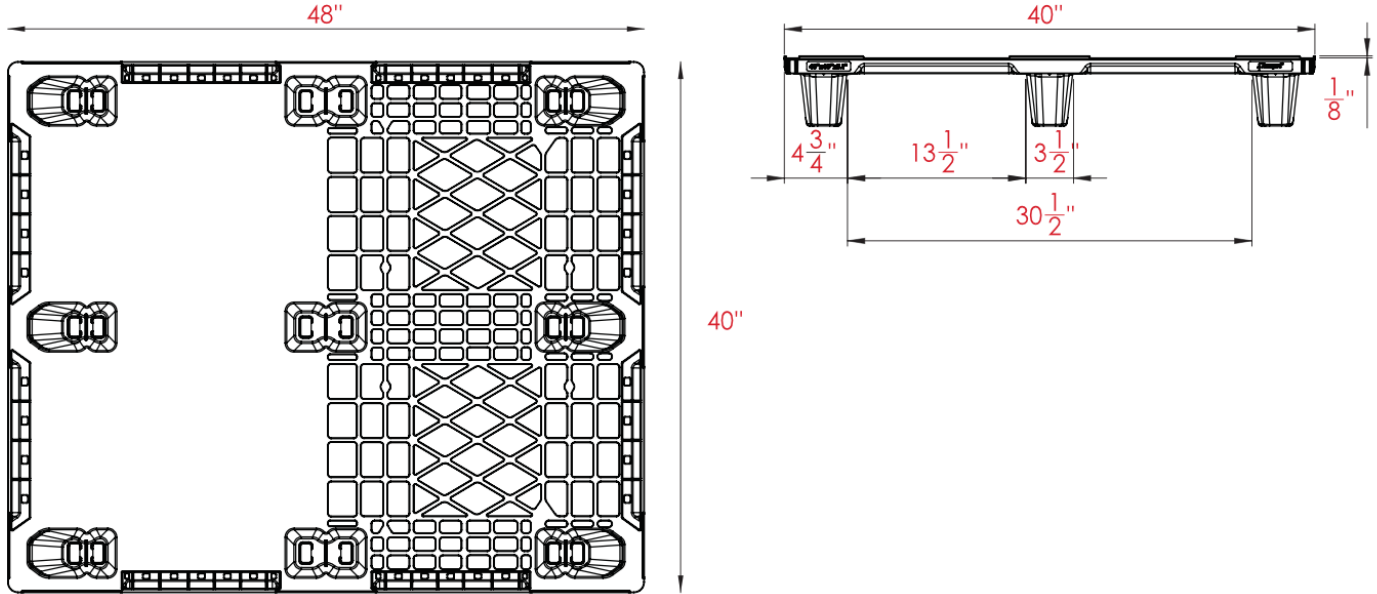

Nelson™

The Nelson Company
(443) 649-5294

plastic@NelsonCompany.com

www.NelsonCompany.com

www.NelsonTechCenter.com

Tech Sheet Generated On: 3/22/2023
Specs subject to change without notice. Provided for informational purposes only. Technical data are guideline values and may vary based on intended use, features, raw materials and environment. Nothing shall be construed as warranties or guarantees, express or implied, regarding products or their use, application, performance or otherwise.